



Application

- *Emergency Power System
- *Communication equipment
- *Telecommunication systems
- *Uninterruptible power supplies
- *Electric bicycle and wheelchairs, etc.
- *Power tools
- *Alarm system
- *Marine equipment
- *Fire and Security System

General Features

- *Safety Sealing
- *Non-spillable construction
- *High Reliability and Stability
- *Sealed and Maintenance-free
- *Safety and Quality certification
- *Long Life and low self-discharge design

Construction

- * Positive Lead dioxide
- * Electrolyte Sulfuric acid
- * Separator Fiber glass
- * Container ABS(UL94-HB) / Flame Retardant ABS
- * Negative Lead
- * Safety Valve EPDR
- * Terminal Copper

Specification

Battery Model	Nominal Voltage		12V		
	Rated capacity (10HR)		150Ah		
Dimensions	Length		Width	Height	Total Height
	567mm (22.32 inches)		110mm(4.33 inches)	283mm(11.30 inches)	296mm (11.65 inches)
Approx Weight	44.5kg(98.10lbs) ±3%				
Capacity 25°C (77°F)	20 hr (7.60A,10.8V)	10hr(15.0A,10.5V)	8 hr (18.54A,10.8V)	5 hr (26.69A,10.5V)	1 hr (87.21A,10.2V)
	152.0AH	150.0AH	148.32AH	133.45AH	87.21AH
Max.discharge current	1500A(5Sec.)				
Internal Resistance	Full charged at 25°C:Approx 4.5 mΩ				
Capacity affected by Temp.(20HR)	50°C	25°C	0°C	-20°C	
	104%	100%	75%	51%	
Self Discharge at 25 °C (77 °F)	After 3 months storage		After 6 months storage		After 12 months storage
	91%		82%		64%
Charge method 25 °C (77 °F)	Cycle Use			Float Use	
	14.4-15.0V(Initial charging current less than 45A)			13.5-13.8V	

Outer dimensions (mm)

Terminal Type (mm)

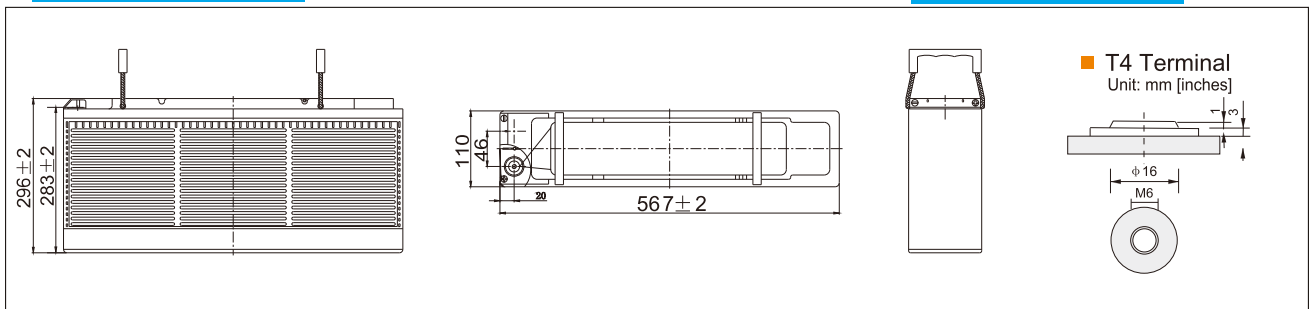

Constant Current(Amp) and Constant Power(Watt) Discharge Table at 25 °C (77 °F)

F.V/time	15MIN	30MIN	60MIN	90MIN	2HR	3HR	5HR	8HR	10HR	20HR
1.60V	247.100	153.000	88.500	64.772	55.527	39.553	26.993	19.113	15.565	8.637
	476.903	304.776	176.558	129.330	111.099	79.139	54.008	38.242	31.142	17.282
1.67V	234.264	149.731	87.859	64.130	55.250	39.346	26.844	18.952	15.323	8.205
	452.482	298.413	175.290	128.081	110.638	78.866	53.808	37.998	30.722	16.452
1.70V	228.487	148.423	87.217	64.066	55.112	39.246	26.837	18.762	15.129	7.987
	441.666	295.817	174.221	128.004	110.408	78.689	53.809	37.636	30.349	16.021
1.75V	218.860	145.808	85.935	63.233	54.766	39.000	26.696	18.710	15.000	7.860
	423.494	290.816	172.083	126.465	109.696	78.234	53.551	37.560	30.113	15.779
1.80V	209.875	142.538	85.293	62.784	54.420	38.793	26.621	18.548	14.758	7.601
	406.737	284.423	171.014	125.881	109.025	77.857	53.429	37.264	29.649	15.270
1.85V	198.964	138.615	84.011	62.078	53.936	38.447	26.472	18.306	14.516	7.342
	385.989	276.795	168.694	124.777	108.103	77.240	53.183	36.814	29.192	14.764

