



Raspberry Pi Camera Module 3

Standard

NoIR

Wide

NoIR Wide

Published December 2023

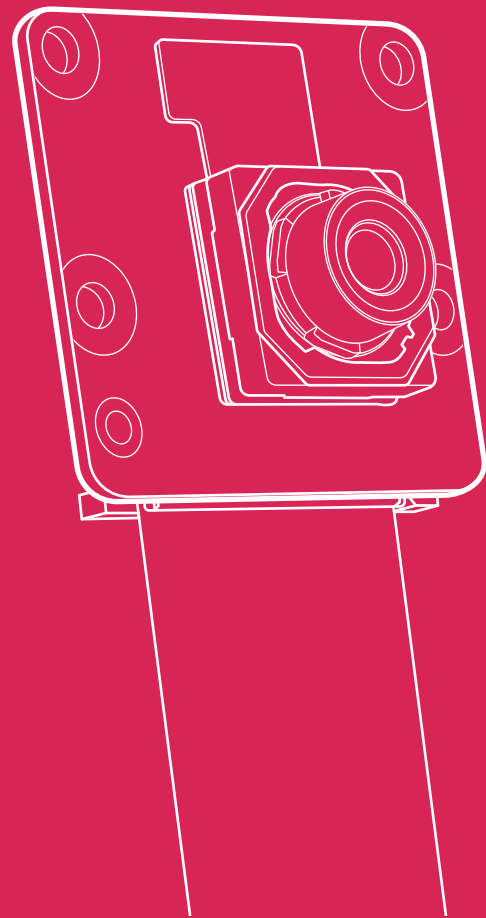
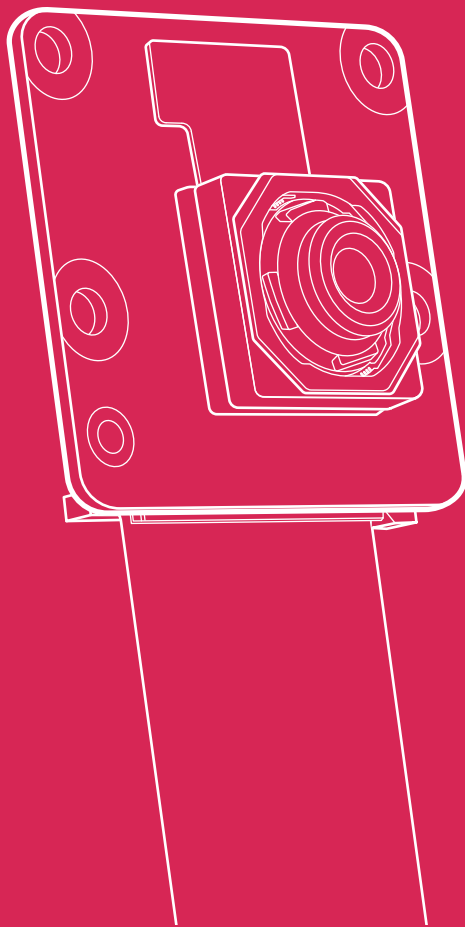

Overview

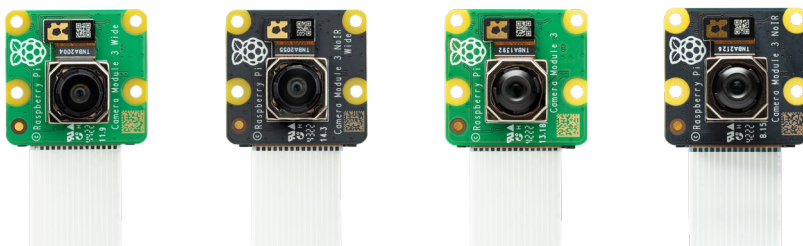

Raspberry Pi Camera Module 3 is a compact camera from Raspberry Pi. It offers an IMX708 12-megapixel sensor with HDR, and features phase detection autofocus. Camera Module 3 is available in standard and wide-angle variants, both of which are available with or without an infrared cut filter.

Camera Module 3 can be used to take full HD video as well as stills photographs, and features an HDR mode up to 3 megapixels. Its operation is fully supported by the libcamera library, including Camera Module 3's rapid autofocus feature: this makes it easy for beginners to use, while offering plenty for advanced users. Camera Module 3 is compatible with all Raspberry Pi computers.¹

The PCB size and mounting holes remain the same as for Camera Module 2. The Z dimension differs: due to the improved optics, Camera Module 3 is several millimetres taller than Camera Module 2.

All variants of Camera Module 3 feature:

- Back-illuminated and stacked CMOS 12-megapixel image sensor (Sony IMX708)
- High signal-to-noise ratio (SNR)
- Built-in 2D Dynamic Defect Pixel Correction (DPC)
- Phase Detection Autofocus (PDAF) for rapid autofocus
- QBC Re-mosaic function
- HDR mode (up to 3 megapixel output)
- CSI-2 serial data output
- 2-wire serial communication (supports I2C fast mode and fast-mode plus)
- 2-wire serial control of focus mechanism

¹ Excluding early Raspberry Pi Zero models, which lack the necessary FPC connector. Later Raspberry Pi Zero models require an adapter FPC, sold separately.

Specification

Sensor:	Sony IMX708
Resolution:	11.9 megapixels
Sensor size:	7.4mm sensor diagonal
Pixel size:	1.4 μ m \times 1.4 μ m
Horizontal/vertical:	4608 \times 2592 pixels
Common video modes:	1080p50, 720p100, 480p120
Output:	RAW10
IR cut filter:	Integrated in standard variants; not present in NoIR variants
Autofocus system:	Phase Detection Autofocus
Dimensions:	25 \times 24 \times 11.5mm (12.4mm height for Wide variants)
Ribbon cable length:	200mm
Cable connector:	15 \times 1mm FPC
Operating temperature:	0°C to 50°C
Compliance:	FCC 47 CFR Part 15, Subpart B, Class B Digital Device Electromagnetic Compatibility Directive (EMC) 2014/30/EU Restriction of Hazardous Substances (RoHS) Directive 2011/65/EU
Production lifetime:	Raspberry Pi Camera Module 3 will remain in production until at least January 2030

Physical specification

Standard lens

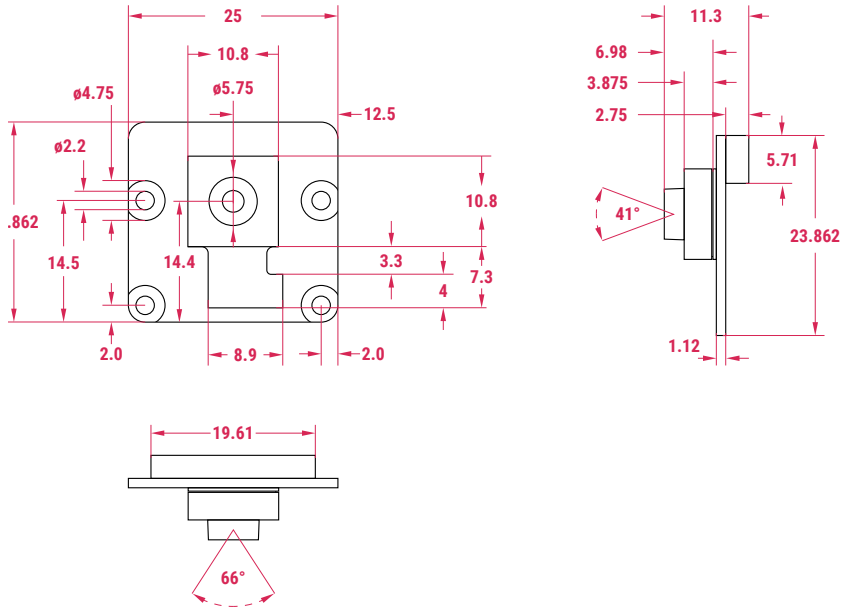

Wide lens

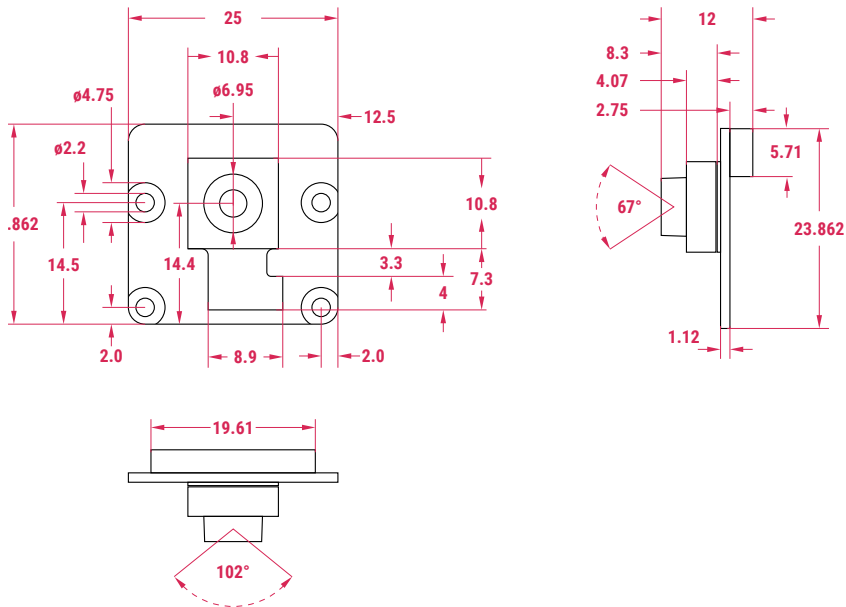

Note: all dimensions in mm
tolerances are accurate to 0.2mm

Variants

	Camera Module 3	Camera Module 3 NoIR	Camera Module 3 Wide	Camera Module 3 Wide NoIR
Focus range	10cm-∞	10cm-∞	5cm-∞	5cm-∞
Focal length	4.74mm	4.74mm	2.75mm	2.75mm
Diagonal field of view	75 degrees	75 degrees	120 degrees	120 degrees
Horizontal field of view	66 degrees	66 degrees	102 degrees	102 degrees
Vertical field of view	41 degrees	41 degrees	67 degrees	67 degrees
Focal ratio (F-stop)	F1.8	F1.8	F2.2	F2.2
Infrared-sensitive	No	Yes	No	Yes

WARNINGS

- This product should be operated in a well ventilated environment, and if used inside a case, the case should not be covered.
- Whilst in use, this product should be firmly secured or should be placed on a stable, flat, non-conductive surface, and should not be contacted by conductive items.
- The connection of incompatible devices to Raspberry Camera Module 3 may affect compliance, result in damage to the unit, and invalidate the warranty.
- All peripherals used with this product should comply with relevant standards for the country of use and be marked accordingly to ensure that safety and performance requirements are met.

SAFETY INSTRUCTIONS

To avoid malfunction or damage to this product, please observe the following:

- **Important:** Before connecting this device, shut down your Raspberry Pi computer and disconnect it from external power.
- If the cable becomes detached, first pull forward the locking mechanism on the connector, then insert the ribbon cable ensuring that the metal contacts face towards the circuit board, and finally push the locking mechanism back into place.
- This device should be operated in a dry environment at 0–50°C.
- Do not expose to water or moisture, or place on a conductive surface whilst in operation.
- Do not expose to heat from any source; Raspberry Pi Camera Module 3 is designed for reliable operation at normal ambient temperatures.
- Store in a cool, dry location.
- Avoid rapid changes of temperature, which can cause moisture to build up in the device, affecting image quality.
- Take care not to fold or strain the ribbon cable.
- Take care whilst handling to avoid mechanical or electrical damage to the printed circuit board and connectors.
- Whilst it is powered, avoid handling the printed circuit board, or handle it only by the edges, to minimise the risk of electrostatic discharge damage.

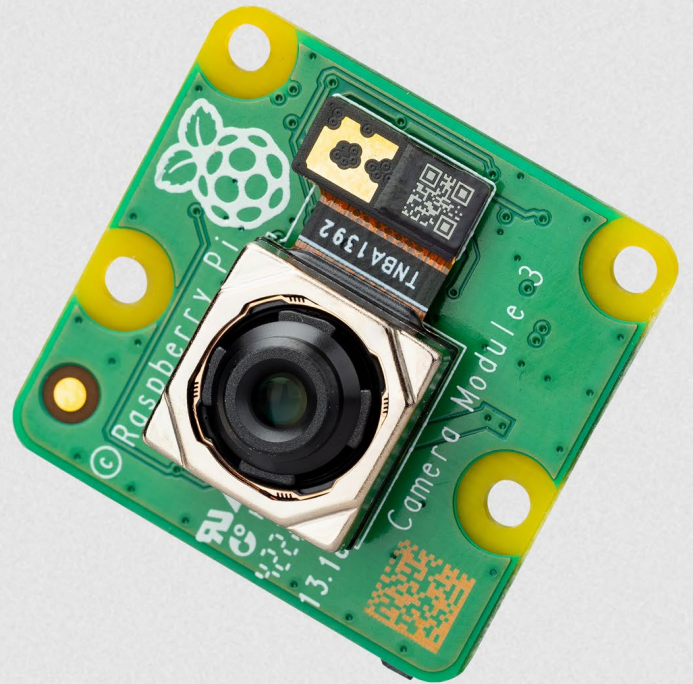
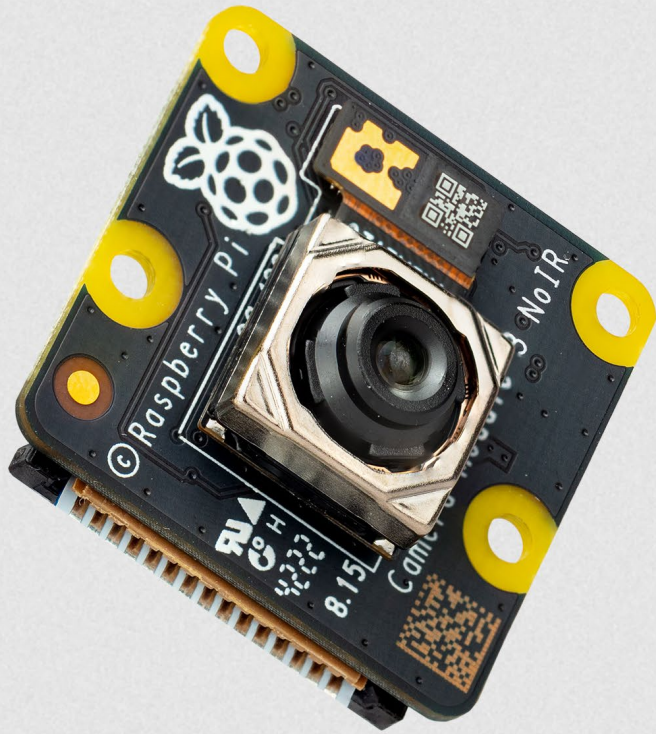
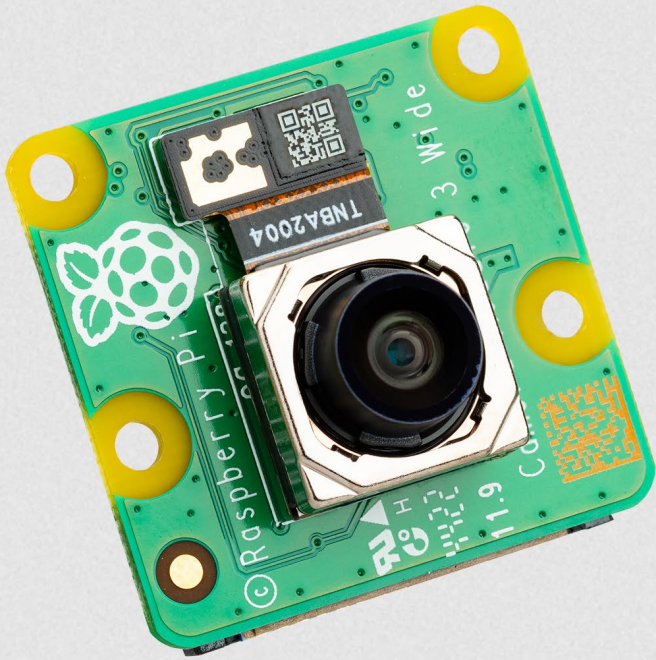



Raspberry Pi is a trademark of Raspberry Pi Ltd
