

**Ana Şanzıman Modeli**

MERCEDES G 3 36

MERCEDES G 3 45

MERCEDES G 3 55

MERCEDES G 3 60

ZF 16 S 130

ZF 16 S 150

ZF 16 S 160

ZF 16 S 190

ZF 16 S 220

ZF 16.190

ZF 20 S 190

ZF 20.190

ZF 4 90

ZF 4 S 120

ZF 4 S 150 GP

ZF 5 110 GP

ZF 5 111 GP

ZF 5 150

ZF 5 24

ZF 5 35

ZF 5 45

ZF 5 50

ZF 5 50

ZF 5 65

ZF 5 90 GP

ZF 5 92 GP

ZF 5 S 110 GP

ZF 5 S 111 GP

ZF 6 36

ZF 6 65

ZF 6 70

ZF 6 75

ZF 6 80

ZF 6 90

ZF 6 S 800 OD

ZF 6 S 800 TO

ZF 65

ZF AK 6 90

ZFS 110

ZFS 4 120

ZFS 5 24

ZFS 5 35

ZFS 5 90

ZFS 6 65

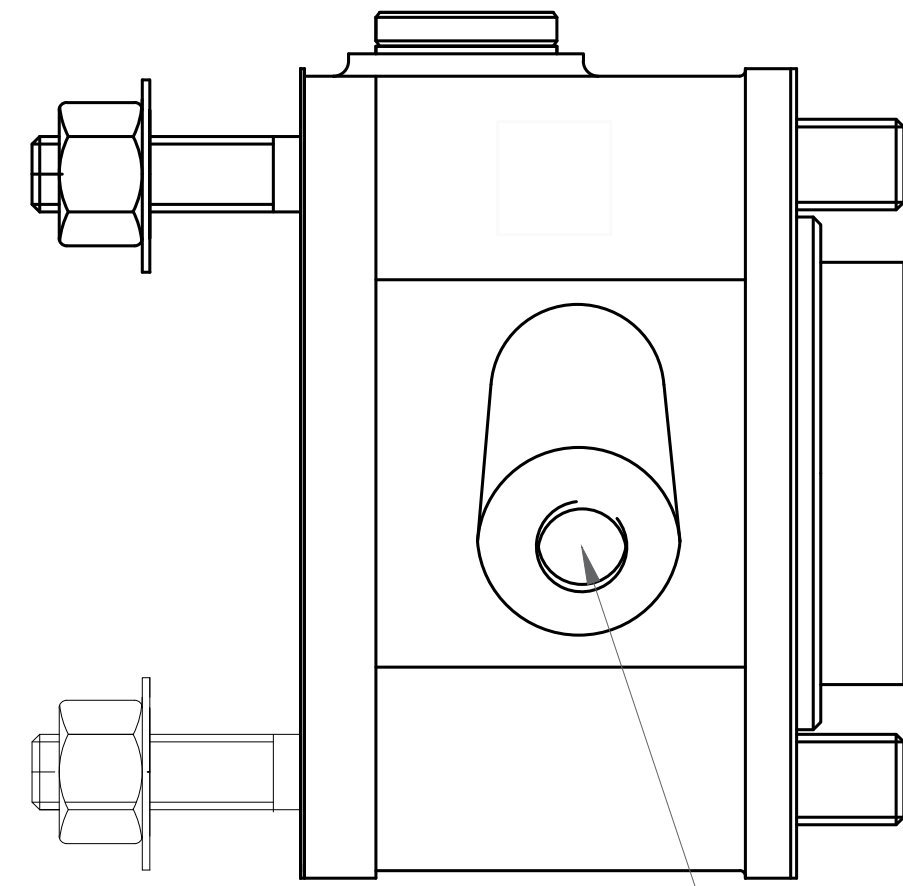
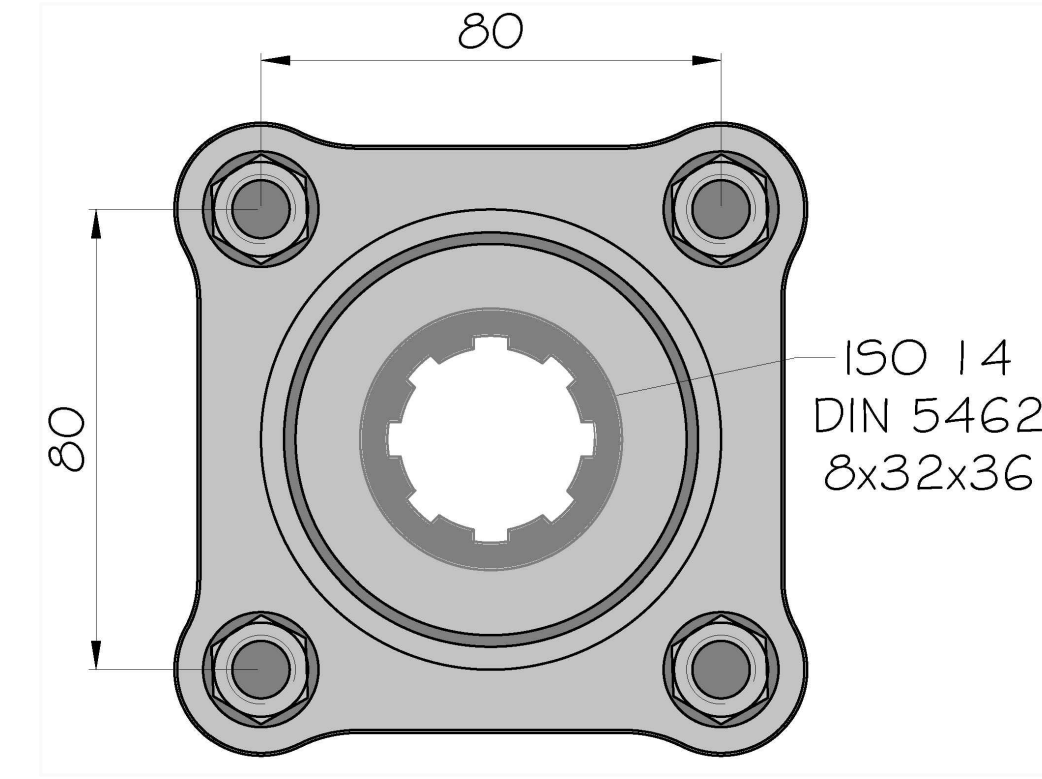
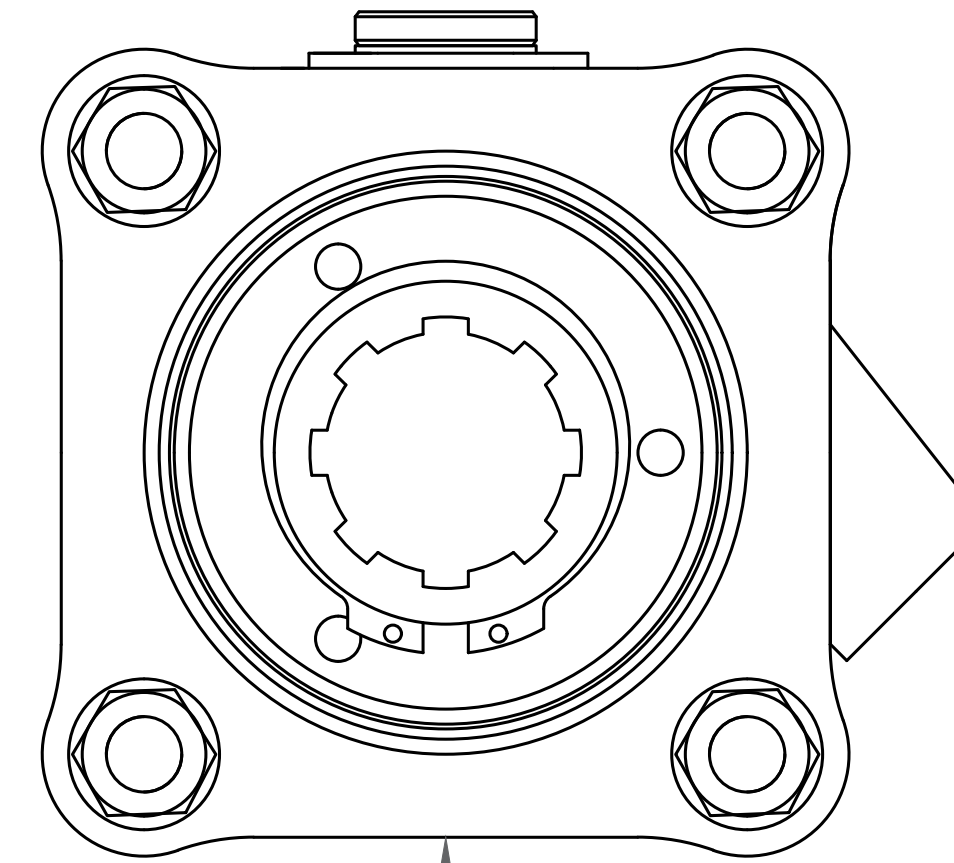
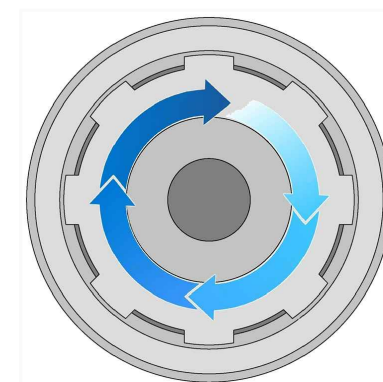

Z=12

Hava Hortum  
Girişi  
R 1/4Pompa Bağlantısı  
Kare Flanş  
Tip PTOPTO Bağlantı Yeri  
Aracın Arka Tarafı  
(Kuyruktan)PTO Mil Dönüş Yönü  
Sağa  
(Saat Yönü)

Pto Kodu	136AC2
Dişli Tipi	Düz
Pto Tipi	Tek Dişli
Tork Nm	300
Güç Kw	22
Tahvil Oranı	1,1
Bağlantı Yeri	Kuyruktan
Kontrol Sistemi	Hava Yastıklı
Pto Mil Dönüş Yönü	Sağa
Ağırlık Kg.	3,20

Ürün Kod  
Detayı

1 3 6 A C 2

Kare Flanşlı - ISO 14 / DIN 5462 - 8x32x36

Akuple

Havalı

Sıra No