

TRUCK WHEEL BALANCER

Installation/Operation & Maintenance Manual

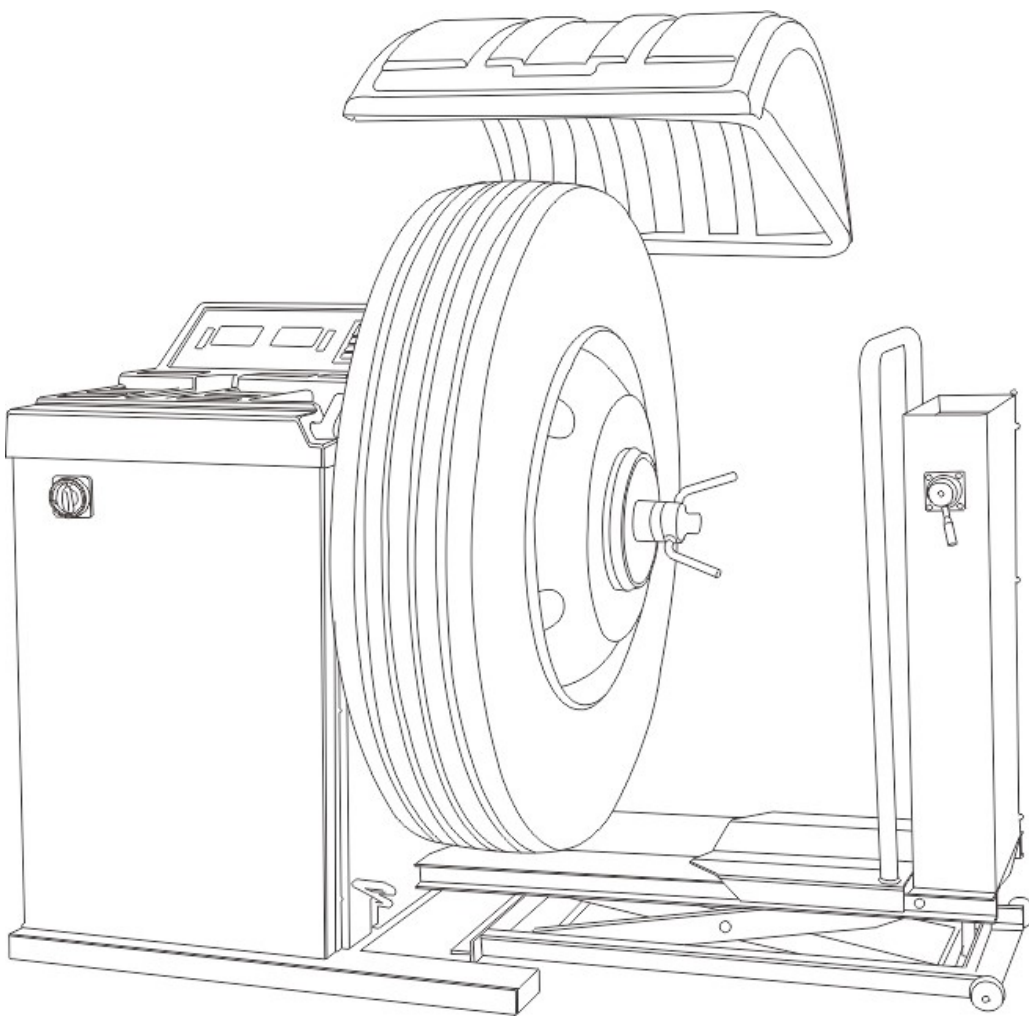

CE

MODEL: JWB790

Please read through this manual before operation. You must read and understand the precautions for safety to protect your safety and any damage to your property.

NOTE TO THE USER

Thank you for purchasing our products.
Please read this instruction carefully for safe and proper use of the wheel balancer, and keep it handy for future reference.

- This Manual is for model : JWB790
- As for the assurance of safety in design and construction of wheel balancer, read this Manual first.
- Please make sure that this manual is delivered to end users for their implementation of safety.
- Don't use the wheel balancer in a potentially explosive atmosphere.

ANY PART OF THIS PRINT MUST NOT BE REPRODUCED
IN ANY FORM WITHOUT PERMISSION.
THIS PRINT IS SUBJECT TO CHANGE WITHOUT NOTICE.

1. INTRODUCTION

Thank you for your purchasing the computer wheel balancer.

1.1 Function

Unbalance wheel results in steering wheel joggling, reduces adhesion force of vehicle, makes the wheels jump and damages tires, shock-absorbers and steering parts. This influences riding comfort and controlling stability and increases oil wear, so that directly influences on vehicle's economical efficiency index. Balancing tire will avoid its disadvantageous effects and loss.

1.2 Performance and Features

- Automatic pneumatic brake system, manual brake position.
- It is easy to lift large sized tire with pneumatic lift.
- This machine adopts imported computer parts, it has world-advanced electric drive system, and its life can be up to ten years.
- High strength protective cover (optional), it accords with national safety operating procedure.
- Under the emergent circumstances, press the key STOP to stop rotating the wheel.
- Having automatic dynamic and static balancing detecting functions.
- Having the functions that balancing three kinds of aluminum alloy rim.
- Balancing precision is up to $\pm 1g$, balancing time is very short.
- Having self-calibration and automatic diagnostic functions

1.3 Technical data

Fit for model 1200 downwards

Rim width	1.5"-20"(38.1-508mm)
Rim diameter	13"-24"(330.2-609.6mm)
Maximum wheel diameter	1300mm
Maximum wheel weight	150Kg
Power supply	380V or 220V(optional)
Noise	$\leq 65dB$
Temperature	0°C-45°C
Floor space	3000×2500mm
Net weight	240Kg

- The Max. weight of wheel can't exceed 95kg when using 220v motor.
- If exceed 95kg, the motor will damage or burn.

2. Transportation and Installation

2.1 Wheel balancer transportation and Installation

- Only lift the balancer's chassis, under any circumstances, do not lift balancer by the main shaft. Pay attention to carry lightly.
- The machine can be installed on any firm and level ground and there is enough space around (not less than 500mm). There are screw holes on the

chassis of the machine, fix the machine into the concrete floor with expansion bolts. And fixing it unstably will produce measurement error.

2.2 Main shaft installation

Before installing, clean up the centre hole of main shaft and connecting piece using alcohol or gasoline, tighten the screw mandrel tightly on the main shaft with spanner.

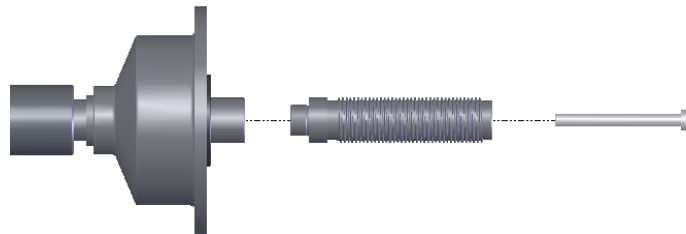

2.3 Warning

-It is recommended that regulated power supply is adopted in the unstable power zone.

-Please read the operation manual carefully before using the machine. If in doubt, do not use the machine and contact its manufacturer.

-Do not remove or replace parts of the machine, otherwise influence normal work of the machine.

-Do not use strong jet of compressed air for cleaning.

-Clean the plastic panel and plastic frame with abstergent termly.

-Do not wear neckcloth and loose clothing with long fair; when the tire rotates, operator should stand on both sides of the machine, and non-operator cannot stand nearby.

-Do not exceed the using range of the machine during the operation process.

-All the electric appliances are installed by professional electrician.

-It is required that the machine is connected with the ground wire. When maintaining the machine, power supply should be turned off.

-Working environment: temperature 0-50°C, in a dry and well airiness area.

3. CONTROL PANEL GRAPHICS:

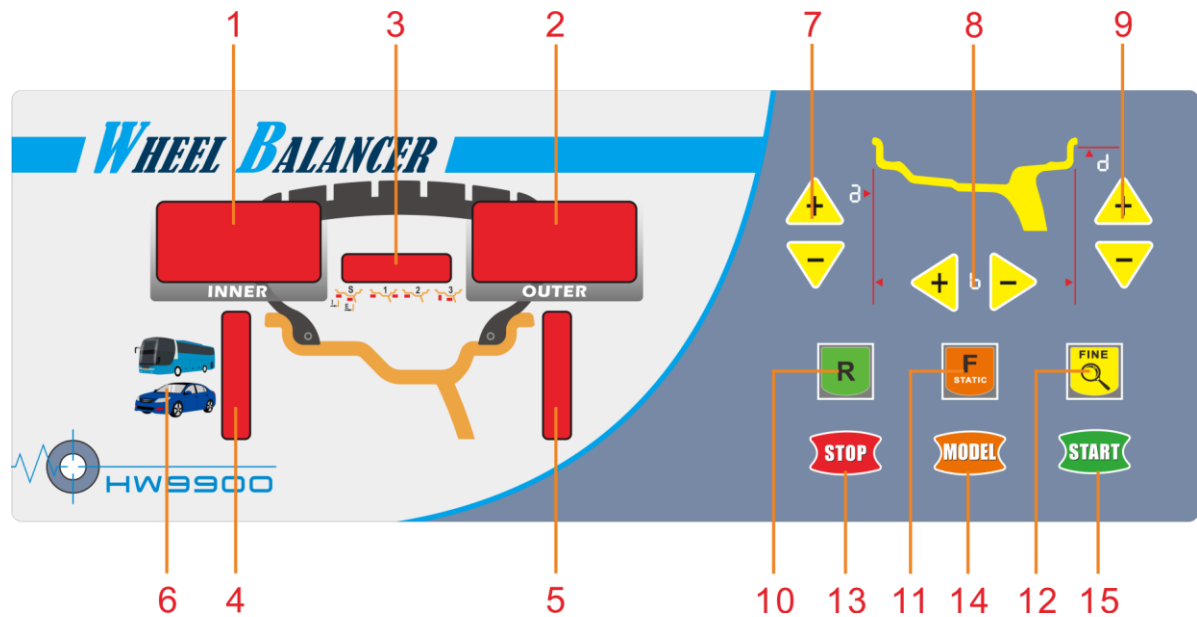

1. Display unbalancing value inside the wheel edge
2. Display unbalancing value outside the wheel edge
3. Display balancing modes
4. Display unbalancing position inside the wheel edge
5. Display unbalancing position outside the wheel edge
6. Indicator for selected small sized and large sized tire balance
7. Function key for manual input the distance between wheel and balancer
8. Function key for manual input of rim width
9. Function key for manual input of rim diameter
10. RESET and ADJUSTMENT key
11. Selected key of balancing mode
12. <5g high accuracy balancing key (car)
<5g high accuracy balancing key (truck)
13. STOP key
14. Select small sized and large sized tire balance
15. START key

Caution: Only press the keys with hands, and do not press the keys using clamp and any other sharp things.

4. WHEEL BALANCING OPERATION PROCESS

4.1 Electrical connection

Open the power switch, and then display the memory logo on the panel, display “-A-”, “8.0” in a few seconds; it proves that the machine is normal.

4.2 Wheel mounting

Preparation before testing: check and clean away dust and clay on the tire, metals and stones in the tire; check whether tire pressure accords with the

regular value; check whether the locating surface of rim and mounting hole have deformed, and check if there are any sundries inside the tire; remove old balancing weights.

4.2.1 Tire mounting

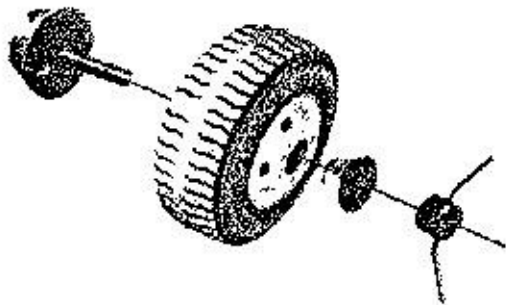

① Fix the screw mandrel on the main shaft.

② Install the tire tested on the main shaft beside the adapter.

③ Select the proper cone to fit over on the main shaft.

④ Tighten with lockwasher nut.

4.2.2 Tire mounting with special flange

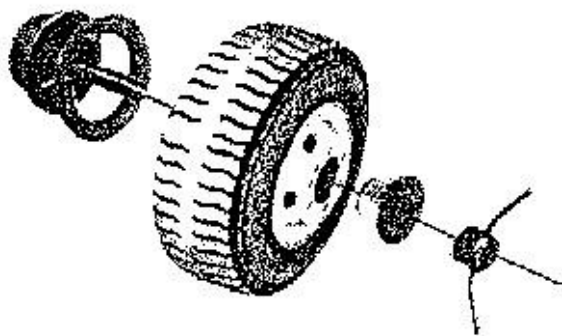

① Install the flange on the adapter, tighten it with bolt.

② Fix the screw mandrel on the main shaft.

③ Select the proper cone to fit over on the main shaft.

④ Tighten with lockwasher nut.

Caution: 1. When fasten the large

sized tire, rotate the tire 180°, fasten it again to make sure the centre of tire positions are accurate.

2. Inner plane of special flange must accord with adapter.

4.3 Dimension input

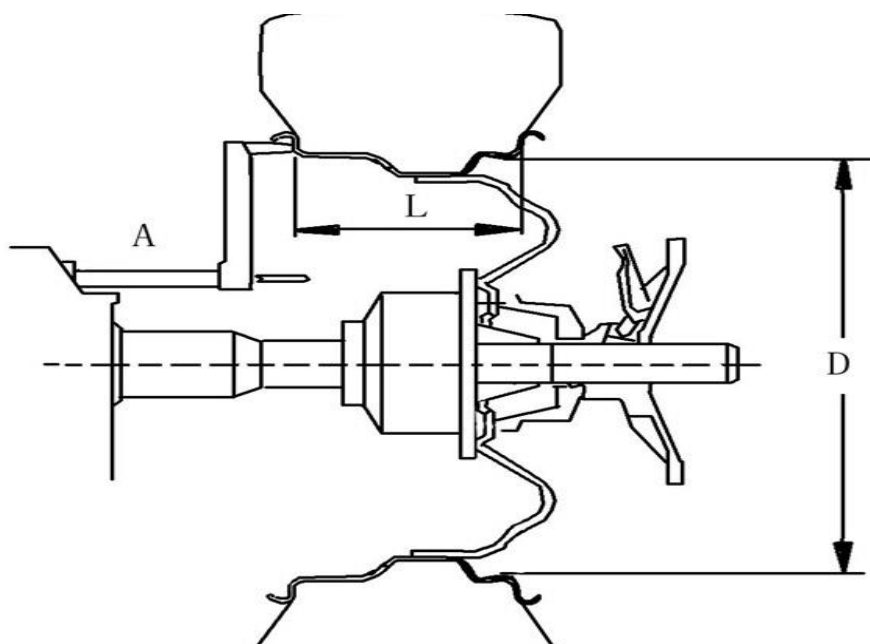

I First input dimension “A”

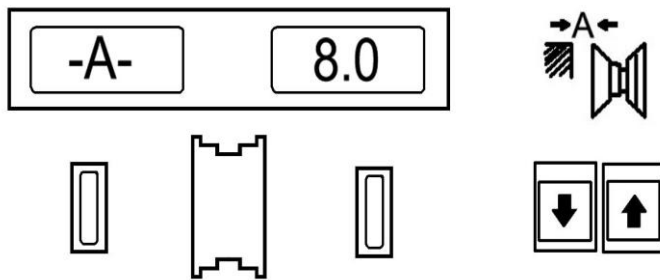

- Measure the distance value “A” from on the inside of rim to the machine body with the distance finding ruler of machine itself.

Press [△], the value increases.

Press [▽], the value reduces.

Until display the value “A” that is measured.

II Then input dimension “L” (B)

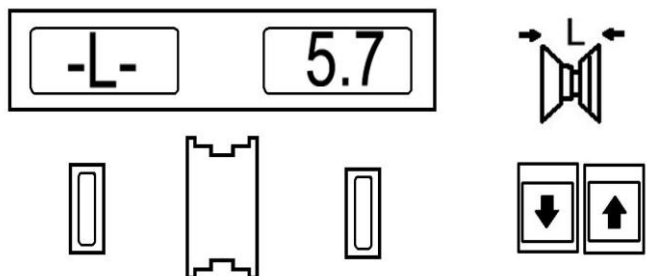

- Measure the width value “L” (B) of rim with width callipers.

Press [△], the value increases.

Press [▽], the value reduces.

Until display the value “L” (B) that is measured.

III Then input dimension “D”

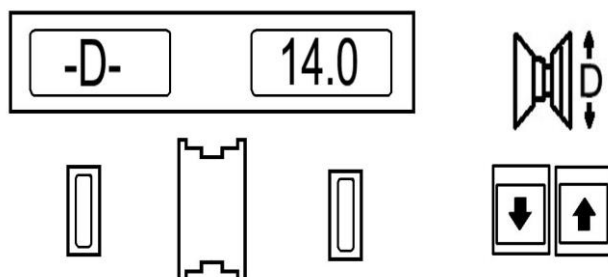

- Find the nominal diameter value “D” on the tire.

Press [△], the value increases.

Press [▽], the value reduces.

Until display the value “D” that is measured.

4.4 Balancing modes

According to wheel material and rim structure, select different balancing modes and the position of balancing weight is also placed differently. Continuously press the key F, select balancing modes based on the state of balancing mode indicator LEDs. When the machine is switched on every time, the system can enter automatically dynamic balancing mode, and need not select.

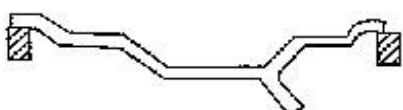

Dynamic balancing—Balance steel or

aluminum alloy rim by clipping the wheel weights onto the rim edges.

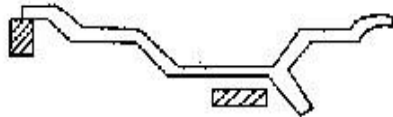
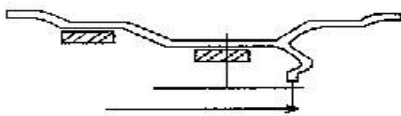
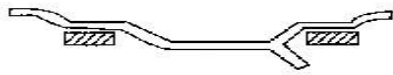

Static balancing—STATIC correction is required for motorcycle wheels or when it is impossible to place the weights on both sides of the rim. The adhesive position of wheel weights as shown in left Figure.

ALU1—Balance alloy rim by placing the adhesive weights onto the rim shoulders. The adhesive position of wheel weights as shown in left Figure.

ALU2—Balance alloy rim by placing the adhesive weights that are hidden on the outside. The adhesive position of wheel weights as shown in left Figure.

ALU3—Balance alloy rim by clipped the wheel weights on the inside and placing the adhesive weights on the outside (the position of wheel weights on the outside as shown in ALU2's figure). The adhesive position of wheel weights as shown in left Figure.

4.5 Balancing wheels

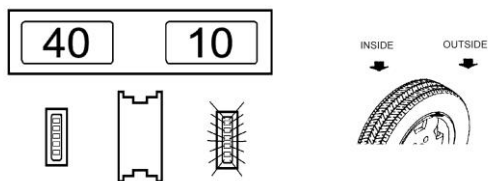

Giving an example as follows:

1. Press startup key START, automatic brake is displayed in 8 seconds, show in Fig.1
40 is unbalancing value inside the tire.
10 is unbalancing value outside the tire.

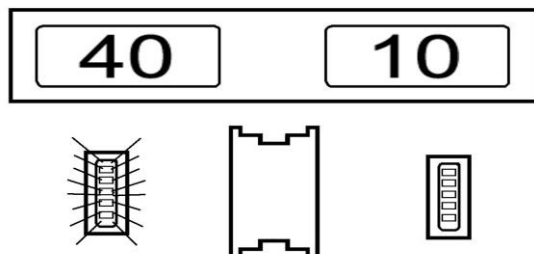

2. Rotate the tire slowly, when all the inner indicator LEDs light, shown in Fig.2, place 40g lead block at twelve o'clock position on the inside of rim. Continue to rotate the tire until a zero (0) appears in the inner LEDs

window, as Fig.3 shown.

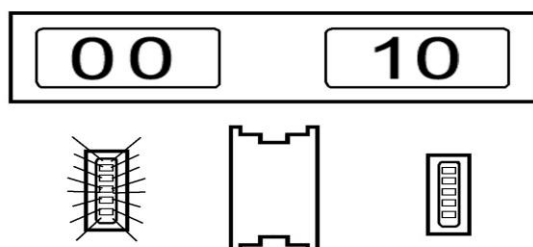

3. Rotate the tire slowly, when all the outer indicator

LEDs light, shown in Fig.4, place 10g lead block at twelve o'clock position on the outside of rim.

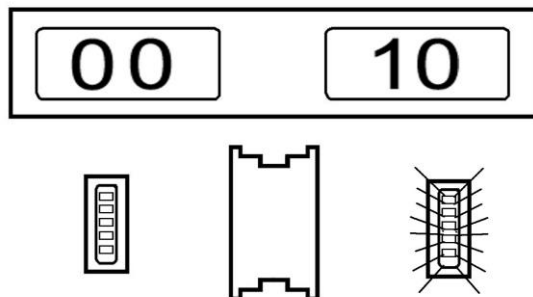

4. Continue to rotate the tire again until a zero (0) appears in the outer LEDs window. After balancing ends, demount the tire. If testing the tire again, do not turn off power supply.

Caution: 1. When the single-phase power is turned on, rotate the tire by hand to extend the motor life.
 2. Check whether input dimension is wrong, press the key R to automatically defect the value A, L, D.
 3. Check whether balancing modes accord with the tire structure.
 (See detailedly 4.4 balancing modes)

4. Check whether the lockwasher nut is tightened.
5. When dismount the tire, care is taken to carry the tire lightly and do not impact the main shaft.
6. When balancing using balancing block with clamp, nail lightly with balance weight on the tire edge. After balancing ends, knock it on the floor and do not knock hard on the main shaft to avoid damaging the sensor.

5. MAINTENANCE

5.1 Self-calibration

Self-calibration is completed in the factory. When using the machine many years later and replace the parts of machine or doubt that balancing error is much greater, self-calibrate over again. Select a medium-sized tire (13 inches or 14 inches), install it on the main shaft, input the value A, L, D of this tire.

Caution: Select the better tire to self-calibrate, input the correct dimension, or else result in calibrating inaccurately.

5.1.1 Self-calibrating with a tire balanced

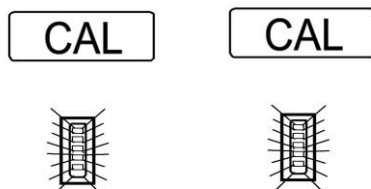

1. First press the keys R & START, the display board displays "CAL"--"CAL". Indicator LEDs blink, release the keys after indicator LEDs go out.

ADD

100

2. Then press the key START, the wheel rotates and automatically brakes, the display board displays “ADD”--“100”, place 100g balancing weight at any position on the outside of the wheel and the rim edge .

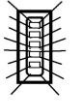

the wheel
the display
which
that self-calibration ends.

End

CAL

3. Then press the key START, rotates and automatically brakes, board displays “END”--“CAL”, indicates

00 100



4. Press the key START again, if displaying “00”--“100” ($\pm 4g$) and outer indicator LEDs blink, 100g balancing weight should be beneath the main shaft (allow having $\pm 4^\circ$ error), which indicates that self-calibration succeeds.

Judging self-calibration accuracy

1. Display numerical value accurately (allow having $\pm 4^\circ$ error).
2. Display phase position accurately (outer indicator LEDs blink, 100g balancing weight is beneath the main shaft and allow having $\pm 4^\circ$ error).

5.1.2 Self-calibrating with a tire unbalanced

1. Repeat the operation 5.1.1, 100g lead block is not beneath the main shaft, the value displayed has error.
2. Remove 100g lead block, balance the wheel (see chapter 4.5), until a zero (0) appears in the inner and outer LEDs window.
3. Repeat the operation 5.1.1 again, if displaying “00”--“100” ($\pm 4g$) and outer indicator LEDs blink, 100g balancing weight should be beneath the main shaft (allow having $\pm 4^\circ$ error), which indicators that self-calibration succeeds.

5.1.3 Self-calibration trouble shooting

Troubles	Reasons	Solutions
Display Err, -8-	<ol style="list-style-type: none"> 1. Do not place 100g lead block. 2. Lead wire of pressure sensor breaks. 3. Mainboard goes wrong. 	<ol style="list-style-type: none"> 1. Place 100g lead block. 2. Check and connect. 3. Replace mainboard.
Error is much greater after self-calibrating.	<ol style="list-style-type: none"> 1. May be error of tire itself is much greater. 2. Three memory parameters confuse. 	<ol style="list-style-type: none"> 1. Replace a balanced standard tire. 2. Adjust three memory parameters and self-calibrate.

<p>The value 100g that is displayed is inaccurate, the position of lead block is not beneath the main shaft, and the tire can be balanced with many lead blocks.</p>	<ol style="list-style-type: none"> 1. The tire is not standard or there are sundries in the tire 2. Memory values dis and SFA do not adjust well. 3. The value that is display is inaccurate. 	<ol style="list-style-type: none"> 1. Replace a standard tire. 2.1 If the displayed value is high, reduce the value dis. 2.2 If the displayed value is low, increase the value dis. 2.3 When lead block is away from the operator, increase the value SFA. 2.4 When lead block is back from the operator, reduce the value SFA. 3. Shoot according to trouble shooting.
--	--	---

If do not resolve by the above methods, please contact the manufacturer.

Caution: After replacing mainboard, power panel, phase position and pressure position, self-calibration must be carried out over again. When replace mainboard, setup its parameters according to original parameters, the method sees 5.2. And self-calibrate over again after modifying.

5.2 Correcting memory data

Because incorrect operations and other reasons result in losing memory parameters, adjust as follows and make the computer return normal work. Correct parameter setup can guarantee its balancing precision.

Trouble: After self-calibrating, the phase position is inaccurate or the error is too greater.

Correcting method as follows:



out.

Left Window

Right Window

Fig.1

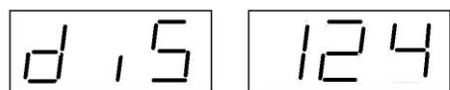

adjust.

Fig.2 Standard Memory

Correcting the degree of accuracy of value



1. First press the keys R & START, the display board displays "CAL"--"CAL". Indicator LEDs of phase position blink, release the keys after indicator LEDs go

2. Continuously press the keys ∇ , Δ and F of distance dimension A, shown in Fig.2, if the value displayed is not correct, press the keys Δ and ∇ of width dimension L to

3. Press the key Δ of distance dimension A, as Fig.3 shown, which is that adjusting static balancing parameters. When offset

data are too many, adjust to shown in Fig.3.

Fig.3 Standard Memory

Correcting value 100g of inner of static balancing

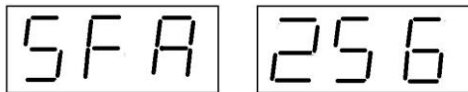

4. Then press the key Δ , as Fig.4 shown, if the value displayed is not correct, press the keys Δ and ∇ of width dimension L and adjust.

Fig.4 Standard Memory

Correcting the error of degree

5. Return by pressing the key Δ of distance dimension A.

6. After correcting, self-calibrate again, see 5.1, or else correct ineffectively.

5.3 Trouble shooting

Troubles	Reasons	Solutions
Do not display after starting.	<ol style="list-style-type: none"> 1. Check outer circuit. 2. Check whether the switch is damaged. 3. Mainboard and power panel are damaged. 	<ol style="list-style-type: none"> 1. Check it with multimeter. 2. Replace it. 3. Replace it.
Display after starting but do not work and buzz, display Err1.	Capacitor of motor did not work.	Replace a 20UF/400V capacitor.
<ol style="list-style-type: none"> 1. Display Err1 and do not rotate. 2. Display Err1 and rotate. 	<ol style="list-style-type: none"> 1. Starting delay is damaged. 2. Phase position generator goes wrong and mainboard is damaged. 3. Power supply voltage is much lower. 	<ol style="list-style-type: none"> 1. Replace delay or power panel. 2. Adjust photoelectric tube shelf, replace mainboard. 3. Boost voltage.
Display Err2 and rotate.	<ol style="list-style-type: none"> 1. Do not install the wheel. 2. Only install rim but not tire. 3. Temperature indoors 	<ol style="list-style-type: none"> 1. Install wheel. 2. Install tire. 3. Make sure that temperature indoors is more than 5°C.

	is much lower, wheel inertia is not good.	
Display Err3	Unbalance amount of wheel is much greater.	Replace wheel or self-calibrate over again.
Display Err4	<ol style="list-style-type: none"> 1. If reversal, phase position is connected incorrectly. 2. If corotation, the position of sensor goes wrong. 	<ol style="list-style-type: none"> 1. Change the phase sequence of three phases. 2. Adjust the position again or replace it.
Display Err7	<ol style="list-style-type: none"> 1. Memory is damaged. 2. Signal loses. 	<ol style="list-style-type: none"> 1. Replace X24C45. 2. Self-calibrate over again.
Only display invalid value 00-00.	<ol style="list-style-type: none"> 1. Memory X24C45 is damaged. 2. Lead wire of sensor breaks or is loose contact. 3. Memory value loses. 	<ol style="list-style-type: none"> 1. Replace it 2. Connect over again. 3. Input over again.
The value of changed range every rotation is more than 5g.	<ol style="list-style-type: none"> 1. There are sundries in the tire. 2. Sensor is affected with damp. 3. The machine is place unsteadily. 4. Harmful flow disturbs the machine such as electric portable drill and electric welding machine. 	<ol style="list-style-type: none"> 1. Replace tire. 2. Drying it and adjust again. 3. Tighten fang bolts. 4. Eliminate disturb and try again.
The value of changed range every rotation is more than dozens of grams.	<ol style="list-style-type: none"> 1. There are sundries in the tire. 2. Mainboard or power panel goes wrong. 3. Sensor is placed unsteadily. 4. Outer power voltage is lower. 	<ol style="list-style-type: none"> 1. Replace tire. 2. Replace it. 3. Check sensors and connecting line. 4. Examine and repair or install the manostat.
Non-stopping time is more than 10s.	<ol style="list-style-type: none"> 1. Power supply is loose contact. 2. Disturb. 	<ol style="list-style-type: none"> 1. Check outer power circuitry or replace power supply. 2. Shut down and start again.
Balancing inaccurately and do not up to 00	<ol style="list-style-type: none"> 1. Sensor is affected with damp. 2. Mainboard goes wrong. 3. Program is 	<ol style="list-style-type: none"> 1. Adjust again, drying it and self-calibrate. 2. Replace mainboard. 3. Self-calibrate over again.

	disordered.	
Display value but not brake.	<ol style="list-style-type: none"> 1. Brake system is damaged. 2. External disturbs. 	<ol style="list-style-type: none"> 1. Replace power panel. 2. Start over again.
Twice dismounting error is more than 10g.	<ol style="list-style-type: none"> 1. The inner hole of wheel is not regular. 2. Adapter is installed improperly. 	<ol style="list-style-type: none"> 1. Replace the wheel. 2. Check the assembly surface over again.
Self-calibration displays Err8.	<ol style="list-style-type: none"> 1. Power panel goes wrong. 2. Lead wire of sensor fall back. 	<ol style="list-style-type: none"> 1. Replace wheel and try again. 2. Connect it.
Display error value of several hundred grams	<ol style="list-style-type: none"> 1. Three memory parameters is disordered. 2. Tire error is much greater. 3. Mainboard goes wrong. 	<ol style="list-style-type: none"> 1. Input over again. 2. Replace a tire. 3. Replace mainboard.

6. Structure of pressure sensor and steps of adjustment

During the transportation or operation process, pressure sensors are affected with damp, which results in balancing the tire inaccurately. Then drying pressure sensors. Operate the machine after calibrating.

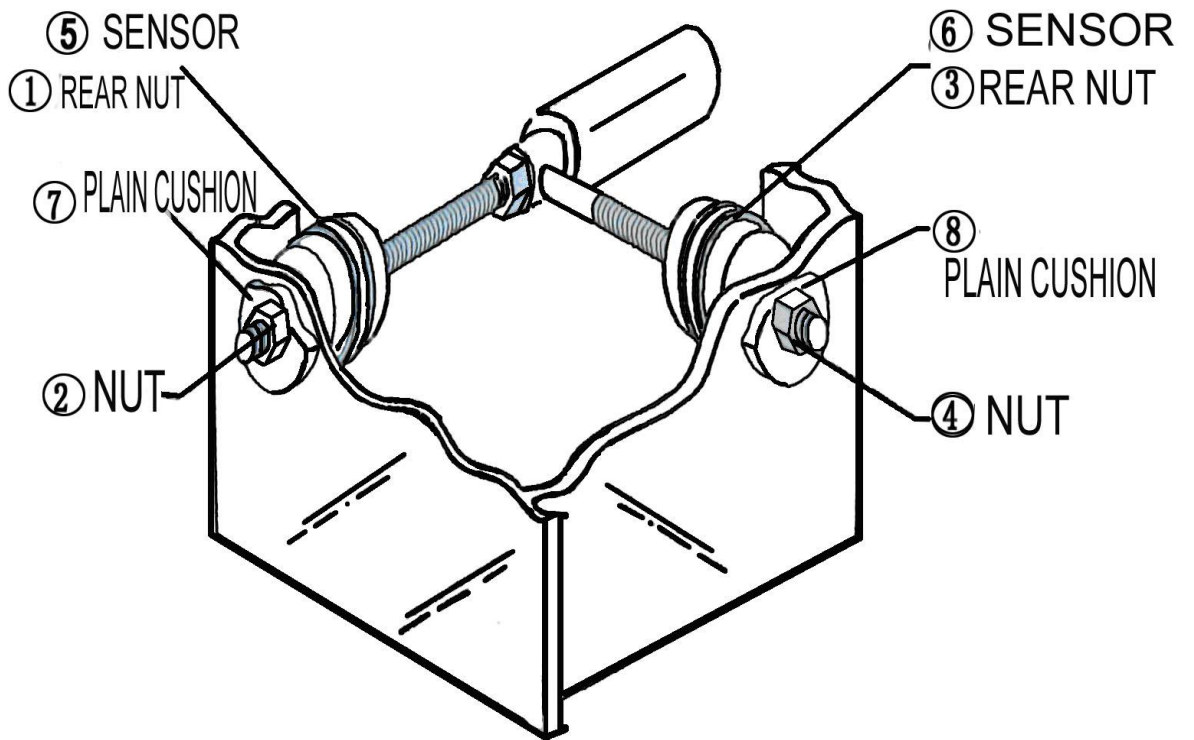

Steps:

1. Loosen nuts ①, ②, ③, ④.
2. Drying sensors ⑤, ⑥.
3. First tighten nut ①, then tighten nut ②.
4. First tighten nut ③, then tighten nut ④.

Caution: The screw mandrel cannot touch the hole edge in the board.

7. Accessories

Number	Name	Quantity
TD01	Lockwasher bolt	1
TD02	Calipers	1
TD03	Balancing plier	1

TD04	Screw mandrel	1
TD05	Flange 1#	1
TD06	Flange 2#	1
TD07	Cone 1#	1
TD08	Cone 2#	1
TD09	Cone 3#	1
TD10	Cone 4#	1
TD11	Cone 5#	1

Accessories figure as follows:

