

GHS 155 x 4 x 4100 C

Stock Code : 43155441003
Reference No : 01-001

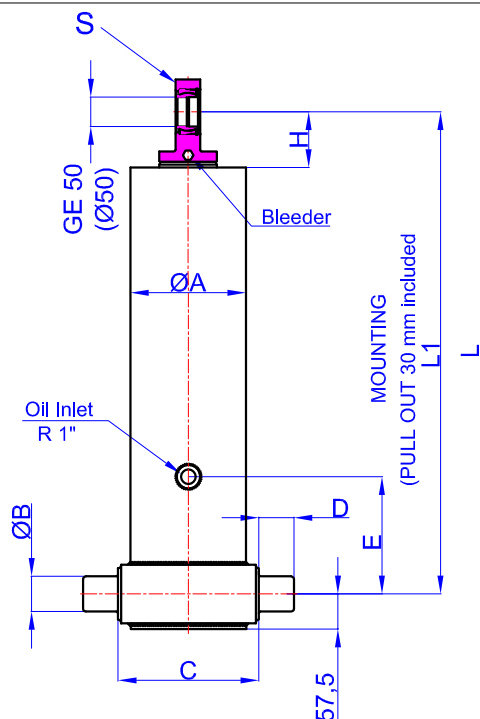

- A : 175 mm
- B : 60 mm
- C : 215 mm
- D : 60 mm
- E : 350 mm
- H : 95 mm
- L : 1310 mm
- *L1 : 1340 mm
- S : 42 mm

* Inc 30 mm pull out :
 tolerance +20 -0
 Hard Chromed all stages
 Working Pressure : 170 Bar
 Max. Working Pressure : 190 Bar
 All Cylinder Materials are St
 52 Cold Drawn Tubes

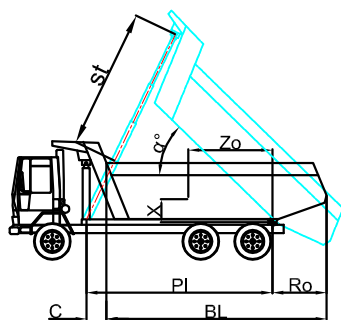

STAGE	1	2	3	4	5	6	7	8	TOTAL
EFFECTIVE DIAMETER (mm)	Ø154,5	Ø135	Ø116	Ø98					
STROKE	1025	1025	1025	1025					4100
OIL DISPLACEMENT (L)	20,5	15,5	11,5	8,5					63
THRUST AT 170 BAR (TONS)	31	24	18	12					

BL (body length)	5200		5000		4800	
Ro (rear overhang)	200	500	200	500	200	500
alpha°	45	48	47	50	49	53
Ycog (vert. pos. centre of gravity)	600		600		600	
PI (Pivot length)	36	41	37	44	39	47
alpha° = st x 60 / PI	40	48	42	52	45	58
	46	58	49	62	53	66
st	3900	3838	3910	3833	3958	3886
					3920	3900
						3920

Weight : 168 Kg

Drawing No : 43155441003-02-001

Bracket : 47000017-0001

- R : 60,8 mm
- S : 70 mm
- T : 192 mm
- U : 312 mm
- V : 76 mm
- Y : 148 mm
- Z : 286 mm

* Bracket are optional

Weight : 9,5 Kg

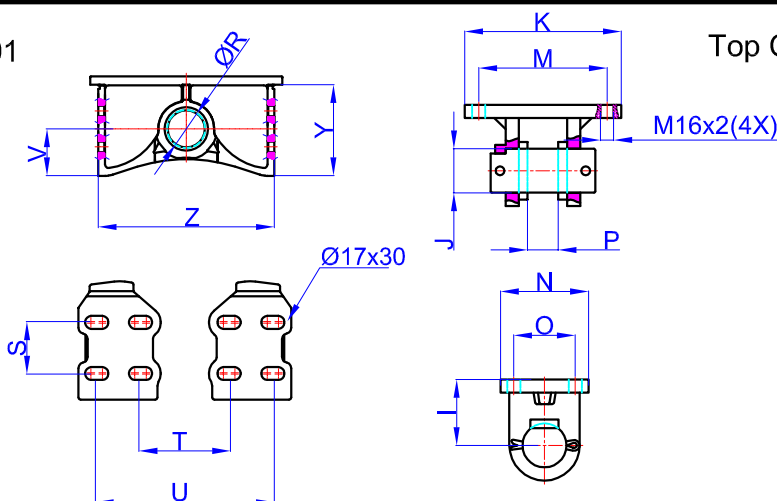

Top Clavis : 47000026-0001

- I : 85 mm
- J : 50 mm
- K : 216 mm
- M : 184 mm
- N : 125 mm
- O : 95 mm
- P : 39 mm

* Bracket are optional