

HYVA CYLINDER

714 06 439



type: UMB 169-6-1540-K258-50-3/4"-HC

tipping weight: 12-23 ton

page # 1 / 2

| | | | | | | | | | | | | | | | | | | | | | | | | | |
|---|---------------------|--|---|---|-----|----|-----|----------------|-----|---|-----|----------------|-----|----------------|----|----|-----|----|----|---|-----|----|----|---|----|
| Stage diameters 169 149 129 110 91 72 | front view cylinder | | <table border="1"> <tr><td>A</td><td>230</td></tr> <tr><td>ØC</td><td>192</td></tr> <tr><td>G¹</td><td>485</td></tr> <tr><td>I</td><td>227</td></tr> <tr><td>K¹</td><td>258</td></tr> <tr><td>M¹</td><td>99</td></tr> <tr><td>ØP</td><td>100</td></tr> <tr><td>ØQ</td><td>65</td></tr> <tr><td>S</td><td>246</td></tr> <tr><td>ØW</td><td>50</td></tr> <tr><td>X</td><td>45</td></tr> </table> | A | 230 | ØC | 192 | G ¹ | 485 | I | 227 | K ¹ | 258 | M ¹ | 99 | ØP | 100 | ØQ | 65 | S | 246 | ØW | 50 | X | 45 |
| A | 230 | | | | | | | | | | | | | | | | | | | | | | | | |
| ØC | 192 | | | | | | | | | | | | | | | | | | | | | | | | |
| G ¹ | 485 | | | | | | | | | | | | | | | | | | | | | | | | |
| I | 227 | | | | | | | | | | | | | | | | | | | | | | | | |
| K ¹ | 258 | | | | | | | | | | | | | | | | | | | | | | | | |
| M ¹ | 99 | | | | | | | | | | | | | | | | | | | | | | | | |
| ØP | 100 | | | | | | | | | | | | | | | | | | | | | | | | |
| ØQ | 65 | | | | | | | | | | | | | | | | | | | | | | | | |
| S | 246 | | | | | | | | | | | | | | | | | | | | | | | | |
| ØW | 50 | | | | | | | | | | | | | | | | | | | | | | | | |
| X | 45 | | | | | | | | | | | | | | | | | | | | | | | | |

¹including 20 mm pull-out [tol. -5; +30 mm]

²cylinder is delivered including oil inlet swivel adapter and cup

specifications

| | |
|---|----------|
| total stroke ¹ | 1540 mm |
| dry weight cylinder only | 79 kg |
| total volume | 20.3 L |
| working volume | 18.7 L |
| maximum pressure | 220 bar |
| maximum pump flow | 61 l/min |
| maximum allowable thrust first stage ³ | 20.0 ton |
| oil inlet | 3/4" BSP |

technical notes

This cylinder is a lifting device only and may not be used as a structural member or be subjected to side load. Sideload and/or poor alignment might result in cylinder leakage. Hyva therefore strongly recommends the use of a cradle, even in instances where the cylinder only tips to the rear or to the side. The cylinder is painted black RAL9005. For suitable hydraulic oils, please refer to data sheet OIL-0011. For details of available brackets and cradles, please refer data sheet 015BRA06.

Detailed calculations can be made using the HYVA Tipper Program, freely available from tipper.hyva.com.

³The cylinder thrust on the first stage (from the HYVA Tipper Program) must not exceed the maximum allowable (see specifications above).

tipping view

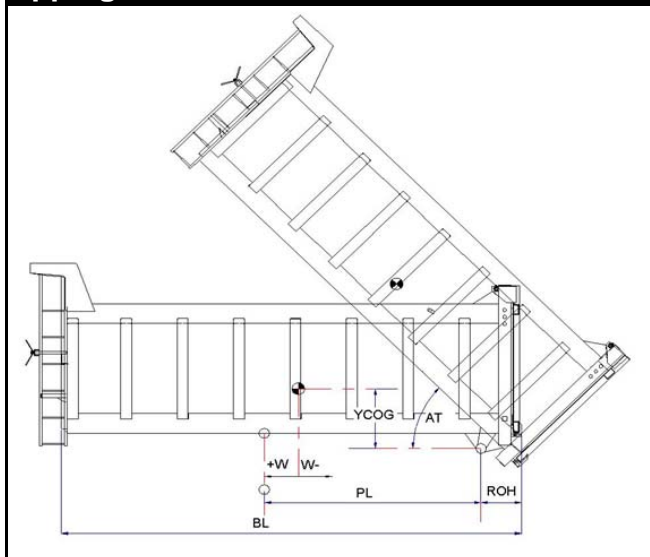

tipping weight

| | | | | | | | |
|--------------------|---|------|------|-----|--|------|------|
| PL | 2010 | | | mm | 1780 | | |
| YCOG | 700 | | | mm | 700 | | |
| ROH | 700 | | | mm | 700 | | |
| BL | 6020 | 5420 | 4930 | mm | 5510 | 4960 | 4510 |
| CYL w.r.t. COG (W) | -300 | 0 | 250 | mm | -280 | 0 | 230 |
| | Tipping weight for full stroke of 46° | | | | Tipping weight for full stroke of 52° | | |
| Tipping weight | 12 | 15 | 18 | ton | 14 | 17 | 21 |
| | Tipping weight for second last stage, up to 38° | | | | Tipping weight for 2nd last stage, up to 43° | | |
| Tipping weight | 17 | 20 | 23 | ton | 17 | 20 | 23 |

HYVA CYLINDER

714 06 439

type

UMB 169-6-1540-K258-50-3/4"-HC

page # 2 / 2

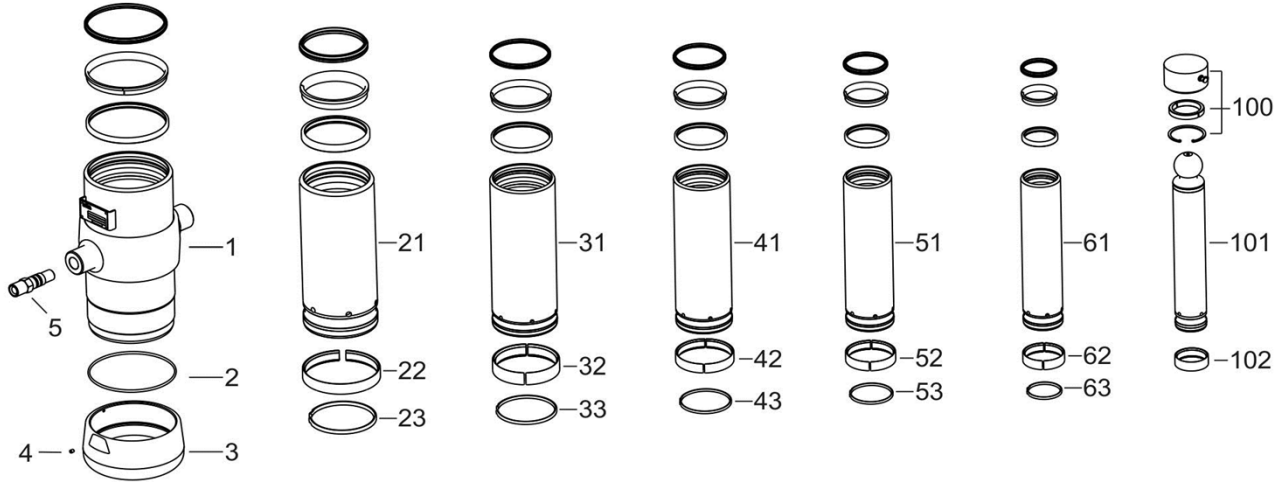

Spare part list

| Pos | Part no. | Description | Qty. |
|-----|------------|---------------------------------------|------|
| 1 | 73507200 | BASE 191-0358-N0159 | 1 |
| 2 | 01226780 | O-RING 184 X 4 70 SHORE | 1 |
| 3 | 73101050 | THREADED BOTTOM UM 191 | 1 |
| 4 | 01792571 | LOCKING SCREW M6X12 INT. HEX. DIN 916 | 1 |
| 5 | 73103002 | OIL INLET ADAPTOR UM 3/4"OT+O-RING | 1 |
| 21 | 73606201 | STAGE 169-0358-HC | 1 |
| 22 | 71807169 K | SLIDER FL 169 | 1 |
| 23 | 71813169 K | LIFTRING FL 169x5 | 1 |
| 31 | 73605201 | STAGE 149-0358-HC | 1 |
| 32 | 71807149 K | SLIDER FL 149 | 1 |
| 33 | 71812149 K | LIFTRING FL 149/HP 150 | 1 |
| 41 | 73604201 | STAGE 129-0358-HC | 1 |
| 42 | 71807129 K | SLIDER FL 129/GF 129 (2 X 1/2) | 1 |
| 43 | 71812129 K | LIFTRING FL 129/HP 129 | 1 |
| 51 | 73603201 | STAGE 110-0358-HC | 1 |
| 52 | 71807110 K | SLIDER FL 110/GF 110 (2 X 1/2) | 1 |
| 53 | 71812110 K | LIFTRING FL 110 | 1 |

Spare part list

| Pos | Part no. | Description | Qty. |
|-----|------------|-------------------------|------|
| 61 | 73602201 | STAGE 091-0358-HC | 1 |
| 62 | 71807091 K | SLIDER FL 091 (2 X 1/2) | 1 |
| 63 | 71812091 K | LIFTRING FL 091 | 1 |
| 100 | 01745102 | RETAINER KIT UMB D.65 | 1 |
| 101 | 73401201 | PISTON B 072-0398-HC | 1 |
| 102 | 71807072 K | SLIDER FL 072 (2 X 1/2) | 1 |

Seal kit complete

| Part no. | Description |
|-------------|--|
| 719 04 660K | Complete packset: Consists of all packsets with packset grease and o-ring. |