



APPROVALS



 **ENGINEERING CODE**
959QA51

 **APPROVED REFRIGERANT**
R-404A

 **POWER SUPPLY**
220-240 V 50 Hz

 **STANDARD CONDITIONS**
ASHRAE

 **APPLICATION**
LBP

 **COOLING CAPACITY**
653 W (LBP)

 **EFFICIENCY**
1.31 W/W (LBP)

 **MOTOR TYPE**
CSIR

 **STARTING TORQUE**
HST

DATA

General Data

Type	Hermetic reciprocating
Technology Type	On-Off
Displacement	12.11 cm ³
Compressor Cooling	Fan/NotControlled/220
Fan Air Flow	520 m ³ /h
Expansion Device	Capillary Tube or Expansion Valve
Horse Power	3/4 hp
Max Condensing Pressure Operating	24.71 bar
Max Condensing Pressure Peak	27.71 bar
Power Supply	220-240 V 50 Hz
Evaporating Temperature Range	-40 °C to -10 °C

Electrical Data

Motor type	CSIR
Starting Torque	HST
Start Winding Resistance	27.95 Ω at 25° C
Run Winding Resistance	5.11 Ω at 25° C

Mechanical Data

Maximum Recommended Refrigerant Charge	350 g
Oil Charge	350 ml
Oil Type Configuration	ESTER
Oil Type Viscosity	ISO22
Pressurization	Dry air charge
Weight	11.1 Kg
Free Internal Volume	2.1 L

Electrical Components

	Description
Start Capacitor	64-77 Uf / 330 V
Starting Device	Relay MTRP-49-65*
Motor Protection	T0964/G6

External Characteristics

Base Plate	European	
Tray Holder	No	
Height	206 mm	
Connector	Internal Diameter	Shape
Suction	8.1 mm	Slanted 42°/Copper
Discharge	6.1 mm	Straight/Copper
Process	6.1 mm	Slanted 42°/Copper

PERFORMANCE

Rated Points

Condensing Temperature	Evaporating Temperature	Cooling Capacity	Power Consumption	Current	Gas Flow Rate	Efficiency
54.40°C	-23.30°C	653 W	499 W	3.06 A	15.09 kg/h	1.31 W/W

Test Condition: ASHRAELBP32, Fan/NotControlled/220, Return Gas 32.2°C, Evaporation -23.30°C, Condensing 54.40°C, Ambient 32.2°C, Liquid 32.2°C, Subcooling 22.2K. Data in accordance to EN

12900:2013 and AHRI 540:2015 polynomial equation and uncertainty guidance.

Performance Curve Data

Condensing Temperature 35°C

Evaporating Temperature °C	Cooling Capacity W	Power W	Current A	Gas Flow Rate kg/h	Efficiency W/W
-40	309	290	2.51	7.08	1.06
-35	409	333	2.59	9.40	1.23
-30	533	377	2.69	12.32	1.41
-25	685	423	2.82	15.87	1.62
-20	862	469	2.97	20.08	1.84
-15	1066	517	3.13	25.00	2.06
-10	1298	565	3.32	30.64	2.3

Test Condition: ASHRAELBP32, Fan/NotControlled/220, Return Gas 32.2°C, Ambient 32.2°C, Liquid 32.2°C. Data in accordance to EN 12900:2013 and AHRI 540:2015 polynomial equation and uncertainty guidance.

Condensing Temperature 45°C

Evaporating Temperature °C	Cooling Capacity W	Power W	Current A	Gas Flow Rate kg/h	Efficiency W/W
-35	381	343	2.62	8.76	1.11
-30	502	397	2.75	11.56	1.27
-25	647	453	2.9	14.98	1.43
-20	819	511	3.09	19.04	1.6
-15	1016	572	3.3	23.78	1.78
-10	1240	636	3.54	29.22	1.95

Test Condition: ASHRAELBP32, Fan/NotControlled/220, Return Gas 32.2°C, Ambient 32.2°C, Liquid 32.2°C. Data in accordance to EN 12900:2013 and AHRI 540:2015 polynomial equation and uncertainty guidance.

Condensing Temperature 55°C

Evaporating Temperature °C	Cooling Capacity W	Power W	Current A	Gas Flow Rate kg/h	Efficiency W/W
-30	458	413	2.79	10.54	1.11
-25	598	477	2.99	13.81	1.25
-20	763	546	3.22	17.71	1.4
-15	953	619	3.49	22.25	1.54
-10	1169	695	3.79	27.48	1.68

Test Condition: ASHRAELBP32, Fan/NotControlled/220, Return Gas 32.2°C, Ambient 32.2°C, Liquid 32.2°C. Data in accordance to EN 12900:2013 and AHRI 540:2015 polynomial equation and uncertainty guidance.

Operating Envelope



External Dimensions

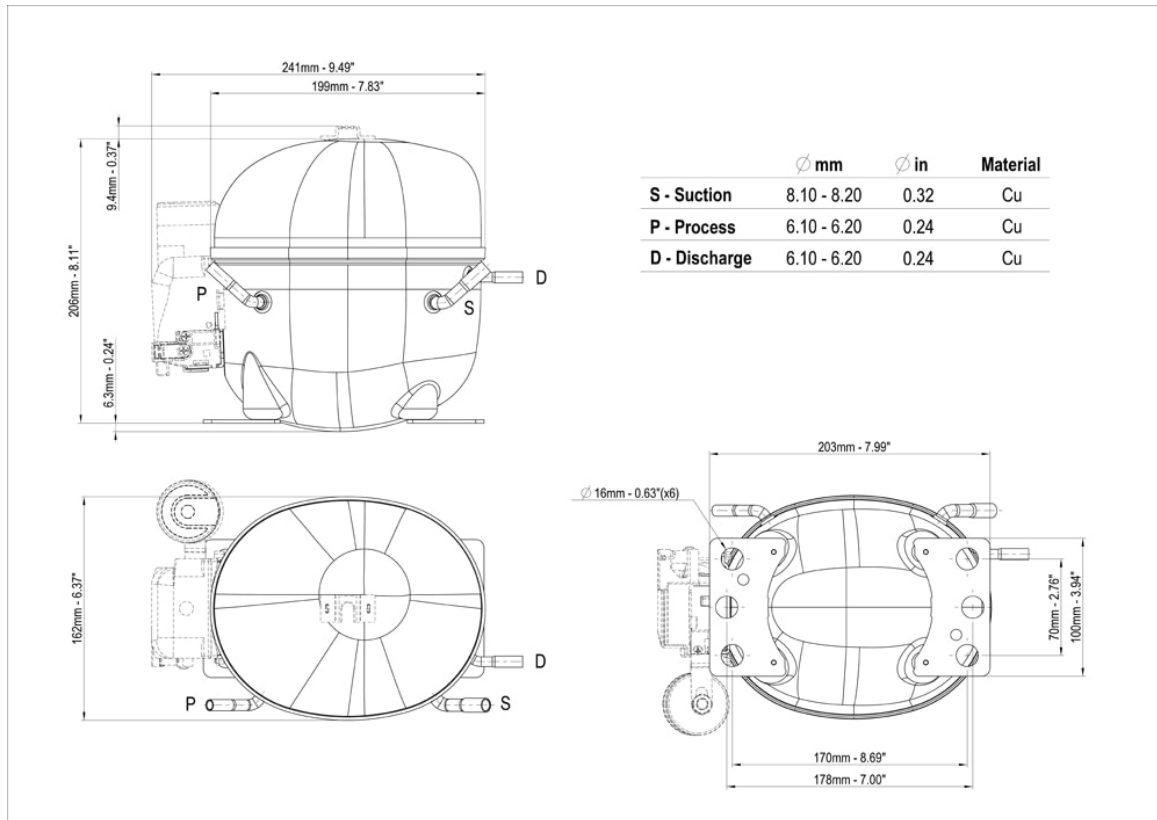

Wiring Diagram

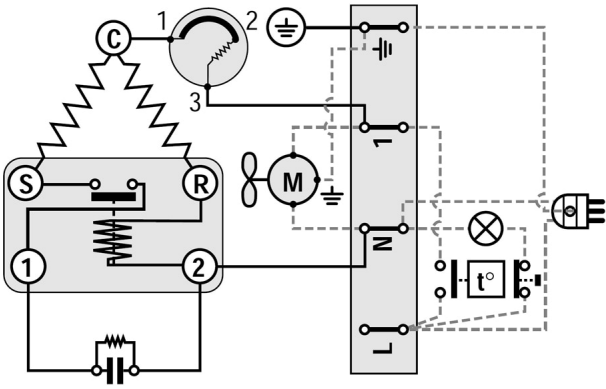

Assembly Instructions

