

HYDRAULIC GEAR
PUMPS AND
MOTORS

POLARIS[®]

INDEX

| Section | Page |
|--|------|
| INTRODUCTION..... | 3 |
| INSTRUCTIONS | 4 |
| FEATURES..... | 5 |
| GEAR PUMPS PERFORMANCE CURVES..... | 9 |
| GEAR MOTORS PERFORMANCE CURVES | 21 |
| SINGLE UNITS DIMENSIONS..... | 34 |
| MULTIPLE PUMPS..... | 39 |
| MULTIPLE PUMPS DIMENSIONS..... | 44 |
| OUTBOARD BEARING OPTIONS | 48 |
| VERSION WITH OUTBOARD BEARING..... | 49 |
| DRIVE SHAFTS..... | 52 |
| MOUNTING FLANGES AND TABLE OF COMPATIBILITY | 58 |
| PORTS POSITION AND TYPE..... | 70 |
| PORTS SIZE | 72 |
| VALVE OPTIONS..... | 76 |
| HOW TO ORDER POLARIS SINGLE UNITS | 78 |
| HOW TO ORDER POLARIS MULTIPLE PUMPS..... | 84 |
| HOW TO ORDER POLARIS DOUBLE PUMPS DIFFERENT GROUPS | 90 |

Replaces: 04/10.2020

05/04.2023



Modification from former edition.

INTRODUCTION

“POLARIS” more than fifty years of Casappa experience in design and production of hydraulic components, characterized by large investments in research and development in order to propose new and personalized solutions to the market.

Our use of CAD 3D in the development of this generation permit us the 3D modelling and the virtual simulation of the behaviour of the components inserted in the hydraulic circuit. This means that the process will take less time and the quality of the products is better.

Polaris pumps and motors are basically composed of a gear housing in aluminium alloy, two gear wheels supported by sleeve bearings and two end plates, the front and the rear cover, either in aluminium or in cast iron with excellent mechanical characteristics.

Our success is based largely on the quality of our product. This guaranties the consistencies of the efficiencies and low level of noise emission during the life of our products.

DISPLACEMENTS

From 1,07 cm³/rev (0.07 in³/rev)
To 91,10 cm³/rev (5.56 in³/rev)

PRESSURE

Max. constant operating pressure 260 bar (3770 psi)
Max. system pressure (relief valve setting) 280 bar (4060 psi)
Max. peak of pressure 300 bar (4350 psi)

SPEED

Max. 4000 min⁻¹

- Available in groups 10, 20 and 30.
- Drive shafts, mounting flanges and ports according to the international standards.
- Combination of multiple pumps in standard version, common inlet and separated stages.
- Integrated outboard bearings for heavy duty application.
- Many types of built-in valves.

TYPICAL APPLICATIONS

- Building & Construction
- Material Handling
- Agriculture
- Forestry
- Turf care & Mowers
- Fan Drive

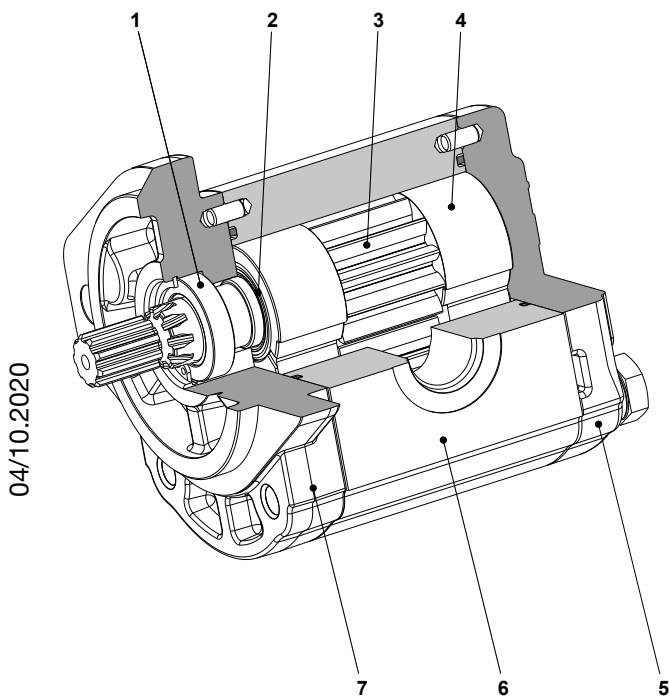

| | |
|---|-----------------|
| 1 | Shaft seal |
| 2 | Seal |
| 3 | Gear |
| 4 | Thrust plate |
| 5 | Rear cover |
| 6 | Body |
| 7 | Mounting flange |

INSTRUCTIONS

INSTALLATION

Pump

The direction of rotation of single-rotation pumps must be the same as that of the drive shaft. Check that the coupling flange correctly aligns the transmission shaft and the pump shaft. Flexible couplings should be used (never rigid fittings) which will not generate an axial or radial load on the pump shaft.

Motor

The direction of rotation of single-rotation motors must match circuit connections. Check that the coupling flange correctly aligns the transmission shaft and the motor shaft. Flexible couplings should be used (never rigid fittings) which will not generate an axial or radial load on the motor shaft.

TANK

Tank capacity must be sufficient for the system's operating conditions (~ 3 times the amount of oil in circulation) to avoid overheating of the fluid. A heat exchanger should be installed if necessary. The intake and return lines in the tank must be spaced apart (by inserting a vertical divider) to prevent the return-line oil from being taken up again immediately.

LINES

The lines must have a major diameter which is at least as large as the diameter of pump or motor ports, and must be perfectly sealed. To reduce loss of power, the lines should be as short as possible, reducing the sources of hydraulic resistance (elbow, throttling, gate valves, etc.) to a minimum. A length of flexible tubing is recommended to reduce the transmission of vibrations. All return lines must end below the minimum oil level, to prevent foaming. Before connecting the lines, remove any plugs and make sure that the lines are perfectly clean.

HYDRAULIC FLUID

Use hydraulic fluid conforming to viscosity data as specified in the first pages of the catalogue. Avoid using mixtures of different oils which could result in decomposition and reduction of the oil's lubricating power.

FILTERS

We recommend filtering the entire system flow. Filters on suction and return line must be fitted in according to the contamination class as indicated in the first pages of the catalogue. Casappa recommends to use its own production filters:

STORAGE

The storage must be in a dry environment.

Max storage time in ideal conditions is 24 months.

The ideal storage temperature is between 5 °C (41 °F) and 20 °C (68 °F). No problem in case of temperature between -40 °C (-40 °F) and 50 °C (122 °F). Below -40 °C (-40 °F) please consult our pre-sales department.

STARTING UP

Check that all circuit connections are tight and that the entire system is completely clean. Insert the oil in the tank, using a filter. Bleed the circuit to assist in filling. Set the pressure relief valves to the lowest possible setting. Turn on the system for a few moments at minimum speed, then bleed the circuit again and check the level of oil in the tank.

If the difference between pump or motor temperature and fluid temperature exceeds 10 °C (18 °F), rapidly switch the system on and off to heat it up gradually. Then gradually increase the pressure and speed of rotation until the pre-set operating levels as specified in the catalogue are attained.

COLD START

Cold start is meant short term and low idle. During cold start of the machine the following limits can be applied:

| | |
|---|--|
| Minimum inlet pressure | 0,5 bar abs. (7 psi) |
| Outlet pressure (pumps) Inlet pressure (motors) | ≤ 50 bar (725 psi) |
| Max drain pressure / Max back pressure for single rotation motors | + 50% of standard values |
| Speed | ≤ 1500 min ⁻¹ |
| Minimum temperature | -40 °C (-40 °F) |
| Max oil viscosity | 2000 mm ² /s (cSt) [9100 SSU] |

If the ambient temperature is lower than -20 °C (-4 °F) the system speed and pressure must be limited until the hydraulic oil temperature exceeds -20 °C (-4 °F).

PERIODICAL CHECKS - MAINTENANCE

Keep the outside surface clean especially in the area of the drive shaft seal. In fact, abrasive powder can accelerate wear on the seal and cause leakage. Replace filters regularly to keep the fluid clean. The oil level must be checked and oil replaced periodically depending on the system's operating conditions.



FEATURES

| | |
|---|---|
| Construction | External gear pumps and motors 3-piece construction |
| Mounting | EUROPEAN - SAE - GERMAN standard flanges |
| Ports | Threaded or flanged |
| Direction of rotation (looking on drive shaft) | Anti-clockwise (S) - clockwise (D) - reversible external drain (R - L) reversible internal drain (B) |
| Inlet pressure range for pumps | 0,7 ÷ 3 bar abs. (10 ÷ 44 psi) If p > 1,5 bar abs. (22 psi) specific shaft sealing have to be applied. Please consult our pre-sales department. |
| Max back pressure for single rotation motors | 5 bar (73 psi) continuous @ min. speed 350 min ⁻¹ 1 bar (14.5 psi) continuous @ max. speed (see page 7) |
| Max drain line pressure on reversible rotation motors | 5 bar (73 psi) continuous @ min. speed 350 min ⁻¹ 1 bar (14.5 psi) continuous @ max. speed (see page 7) |
| Max back pressure on in series motors | 150 bar (2175 psi) |
| Fluid temperature range | See table (1) |
| Fluid | Mineral oil based hydraulic fluids to ISO/DIN. Please contact us for other fluids |
| Viscosity range | From 12 to 100 mm ² /s (cSt) [60 to 456 SSU] recommended Up to 750 mm ² /s (cSt) [3410 SSU] permitted |
| Filtering requirement and recommended fluid contamination | See table (2) page 6 |

Tab. 1

| Type | Fluid composition | Max pressure bar (psi) | Max speed min ⁻¹ | Temperature - °C (°F) | | | Seals (●) | Shaft seals option (◆) |
|---------|--|------------------------|-----------------------------|-----------------------|----------------|-----------|-------------|------------------------|
| | | | | Min | Max continuous | Max peak | | |
| ISO/DIN | Mineral oil based hydraulic fluid to ISO/DIN | See page 7 | See page 7 | -25 (-13) | 80 (176) | 100 (212) | N | D C1 |
| | | | | -25 (-13) | 110 (230) | 125 (257) | V | |
| | | | | -25 (-13) | 110 (230) | 125 (257) | T-PV | |

(●) **N** = Buna NBR (standard) - **V** = Viton-FKM - **T-PV** = Hydrogenated buna HNBR seals with Viton-FKM shaft seals (only for PLP20)

D (◆) shaft seals with wiper seal

C1 (◆) High pressure special shaft seal

04/10.2020

Single rotation pumps

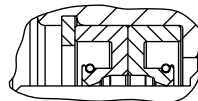
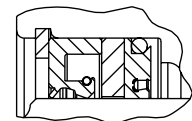
 Max drain line pressure:
0,5 bar (7 psi)

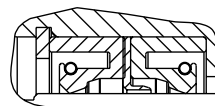
 Max drain line pressure:
10 bar (145 psi)
@ 350 min⁻¹

 Single rotation motors
Reversible rotation pumps and motors

 Max drain line pressure:
5 bar (73 psi)
@ 350 min⁻¹

FEATURES

Filtration

Casappa recommends to use its own production filters:



Tab. 2

| Working pressure bar (psi) | $\Delta p < 140$ (2030) | $140 < \Delta p < 210$ (2030) (3045) | $\Delta p > 210$ (3045) |
|--|----------------------------|---|----------------------------|
| Contamination class NAS 1638 | 10 | 9 | 8 |
| Contamination class ISO 4406 | 21/19/16 | 20/18/15 | 19/17/14 |
| Achieved with filter $\beta_{10}(c) \geq 75$ according to ISO 16889 | - | 10 μm | 10 μm |
| Achieved with filter $\beta_{25}(c) \geq 200$ according to ISO 16889 | 25 μm | - | - |

DEFINITION OF ROTATION DIRECTION LOOKING AT THE DRIVE SHAFT

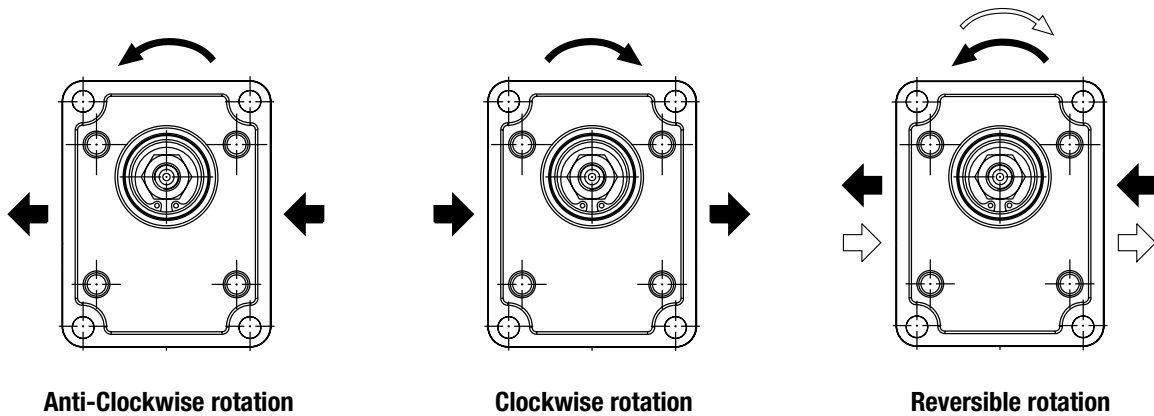

GENERAL NOTES

Available with different inlet and outlet ports.
Please contact us for more information.

PRESSURE DEFINITION

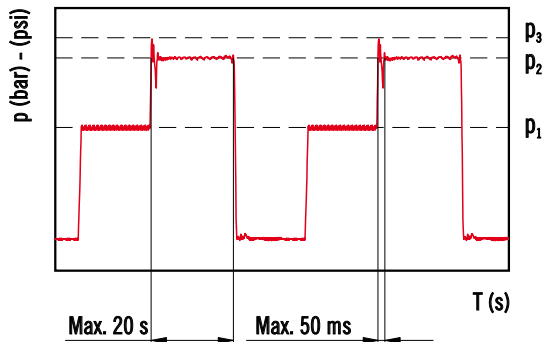

- p_1 Constant operating pressure
- p_2 System pressure (relief valve setting)
- p_3 Peak of pressure

The peak of pressure is the max pressure allowed and it corresponds to the overshoot of the relief valve.

Please note that both relief valve setting and overshoot must be lower than their limits.
If the relief setting is compliant but the overshoot is higher than the limit, the relief setting must be decreased until the overshoot is compliant to Casappa limit.

Please contact us for high frequency applications.

04/10.2020

FEATURES

| Series | Pump type PLP Motor type PLM | Displacement cm ³ /rev (in ³ /rev) | Max. pressure | | | Max. speed | Min. speed min ⁻¹ |
|--------------------|---------------------------------|---|----------------|----------------|----------------|------------|---------------------------------|
| | | | P ₁ | P ₂ | P ₃ | | |
| | | | bar (psi) | | | | |
| POLARIS 10 | PL. 10•1 | 1,07 (0.07) | 260 (3770) | 280 (4060) | 290 (4205) | 4000 | 650 |
| | PL. 10•1,5 | 1,60 (0.10) | 260 (3770) | 280 (4060) | 290 (4205) | 4000 | 650 |
| | PL. 10•2 | 2,13 (0.13) | 260 (3770) | 280 (4060) | 290 (4205) | 4000 | 650 |
| | PL. 10•2,5 | 2,67 (0.16) | 260 (3770) | 280 (4060) | 290 (4205) | 4000 | 650 |
| | PL. 10•3,15 | 3,34 (0.20) | 260 (3770) | 280 (4060) | 290 (4205) | 4000 | 650 |
| | PL. 10•4 | 4,27 (0.26) | 250 (3625) | 270 (3915) | 280 (4060) | 4000 | 650 |
| | PL. 10•5 | 5,34 (0.33) | 250 (3625) | 270 (3915) | 280 (4060) | 4000 | 650 |
| | PL. 10•5,8 | 6,20 (0.38) | 230 (3335) | 250 (3625) | 260 (3770) | 3500 | 650 |
| | PL. 10•6,3 | 6,67 (0.41) | 230 (3335) | 250 (3625) | 260 (3770) | 3500 | 650 |
| | PL. 10•8 | 8,51 (0.52) | 180 (2610) | 200 (2900) | 210 (3045) | 3500 | 650 |
| PL. 10•10 | 10,67 (0.65) | 140 (2030) | 160 (2320) | 170 (2465) | 3500 | 650 | |
| POLARIS 20 | PL. 20•4 | 4,95 (0.30) | 250 (3625) | 280 (4060) | 300 (4350) | 4000 | 600 |
| | PL. 20•6,3 | 6,61 (0.40) | 250 (3625) | 280 (4060) | 300 (4350) | 4000 | 600 |
| | PL. 20•7,2 | 7,29 (0.44) | 250 (3625) | 280 (4060) | 300 (4350) | 4000 | 600 |
| | PL. 20•8 | 8,26 (0.50) | 250 (3625) | 280 (4060) | 300 (4350) | 3500 | 600 |
| | PL. 20•9 | 9,17 (0.56) | 250 (3625) | 280 (4060) | 300 (4350) | 3500 | 600 |
| | PL. 20•10,5 | 10,9 (0.66) | 250 (3625) | 280 (4060) | 300 (4350) | 3500 | 600 |
| | PL. 20•11,2 | 11,23 (0.69) | 250 (3625) | 280 (4060) | 300 (4350) | 3500 | 600 |
| | PL. 20•14 | 14,53 (0.89) | 250 (3625) | 280 (4060) | 300 (4350) | 3500 | 500 |
| | PL. 20•16 | 16,85 (1.03) | 250 (3625) | 280 (4060) | 300 (4350) | 3000 | 500 |
| | PL. 20•19 | 19,09 (1.16) | 200 (2900) | 220 (3190) | 240 (3480) | 3000 | 500 |
| | PL. 20•20 | 21,14 (1.29) | 200 (2900) | 220 (3190) | 240 (3480) | 3000 | 500 |
| | PL. 20•24,5 | 24,84 (1.52) | 170 (2465) | 190 (2755) | 210 (3045) | 2500 | 500 |
| | PL. 20•25 | 26,42 (1.61) | 170 (2465) | 190 (2755) | 210 (3045) | 2500 | 500 |
| PL. 20•27,8 | 28,21 (1.72) | 130 (1885) | 150 (2175) | 170 (2465) | 2000 | 500 | |
| PL. 20•31,5 | 33,03 (2.01) | 130 (1885) | 150 (2175) | 170 (2465) | 2000 | 500 | |
| POLARIS 30 | PL. 30•22 | 21,99 (1.34) | 250 (3625) | 270 (3915) | 280 (4060) | 3000 | 350 |
| | PL. 30•27 | 26,70 (1.63) | 250 (3625) | 270 (3915) | 280 (4060) | 3000 | 350 |
| | PL. 30•34 | 34,55 (2.11) | 240 (3480) | 260 (3770) | 270 (3915) | 3000 | 350 |
| | PL. 30•38 | 39,27 (2.40) | 240 (3480) | 260 (3770) | 270 (3915) | 3000 | 350 |
| | PL. 30•43 | 43,98 (2.68) | 230 (3335) | 250 (3625) | 260 (3770) | 3000 | 350 |
| | PL. 30•51 | 51,83 (3.16) | 210 (3045) | 230 (3335) | 240 (3480) | 2500 | 350 |
| | PL. 30•61 | 61,26 (3.74) | 190 (2755) | 210 (3045) | 220 (3190) | 2500 | 350 |
| | PL. 30•73 | 73,82 (4.50) | 170 (2465) | 190 (2755) | 200 (2900) | 2500 | 350 |
| | PL. 30•82 | 81,68 (4.98) | 160 (2320) | 170 (2465) | 180 (2610) | 2200 | 350 |
| PL. 30•90 | 91,10 (5.56) | 150 (2175) | 160 (2320) | 170 (2465) | 2200 | 350 | |

04/10.2020

Pressure values in the table refer to side ports unidirectional pumps and motors.
 For reversible pumps and motors, max pressures are 250 bar (3600 psi) excepted those with lower pressure values.
 Please contact us for different working conditions.

GENERAL DATA PUMPS AND MOTORS

| | | |
|---|---|-----------------------------|
| Q | l/min (US gpm) | Flow |
| M | Nm (lbf in) | Torque |
| P | kW (HP) | Power |
| V | cm ³ /rev (in ³ /rev) | Displacement |
| n | min ⁻¹ | Speed |
| Δp | bar (psi) | Pressure |
| $\eta_v = \eta_v(V, \Delta p, n)$ | | Volumetric efficiency |
| $\eta_{hm} = \eta_{hm}(V, \Delta p, n)$ | | Hydro-mechanical efficiency |
| $\eta_t = \eta_v \cdot \eta_{hm}$ | | Overall efficiency |



Replaces: 03/02.2012

DESIGN CALCULATIONS FOR PUMP

$$Q = Q_{\text{theor.}} \cdot \eta_v \quad [\text{l/min}]$$

$$Q_{\text{theor.}} = \frac{V \cdot n}{1000} \quad [\text{l/min}]$$

$$M = \frac{M_{\text{theor.}}}{\eta_{hm}} \quad [\text{Nm}]$$

$$M_{\text{theor.}} = \frac{\Delta p \cdot V}{62,83} \quad [\text{Nm}]$$

$$P_{\text{IN}} = \frac{P_{\text{OUT}}}{\eta_t} \quad [\text{kW}]$$

$$P_{\text{OUT}} = \frac{\Delta p \cdot Q}{600} \quad [\text{kW}]$$

DESIGN CALCULATIONS FOR MOTOR

$$Q = \frac{Q_{\text{theor.}}}{\eta_v} \quad [\text{l/min}]$$

$$Q_{\text{theor.}} = \frac{V \cdot n}{1000} \quad [\text{l/min}]$$

$$M = M_{\text{theor.}} \cdot \eta_{hm} \quad [\text{Nm}]$$

$$M_{\text{theor.}} = \frac{\Delta p \cdot V}{62,83} \quad [\text{Nm}]$$

$$P_{\text{IN}} = \frac{\Delta p \cdot Q}{600} \quad [\text{kW}]$$

$$P_{\text{OUT}} = P_{\text{IN}} \cdot \eta_t \quad [\text{kW}]$$

 05/04.2023

NOTES

Diagrams providing approximate selection data will be found on subsequent pages.

PLP 10

POLARIS 10 GEAR PUMPS PERFORMANCE CURVES

PLP 10

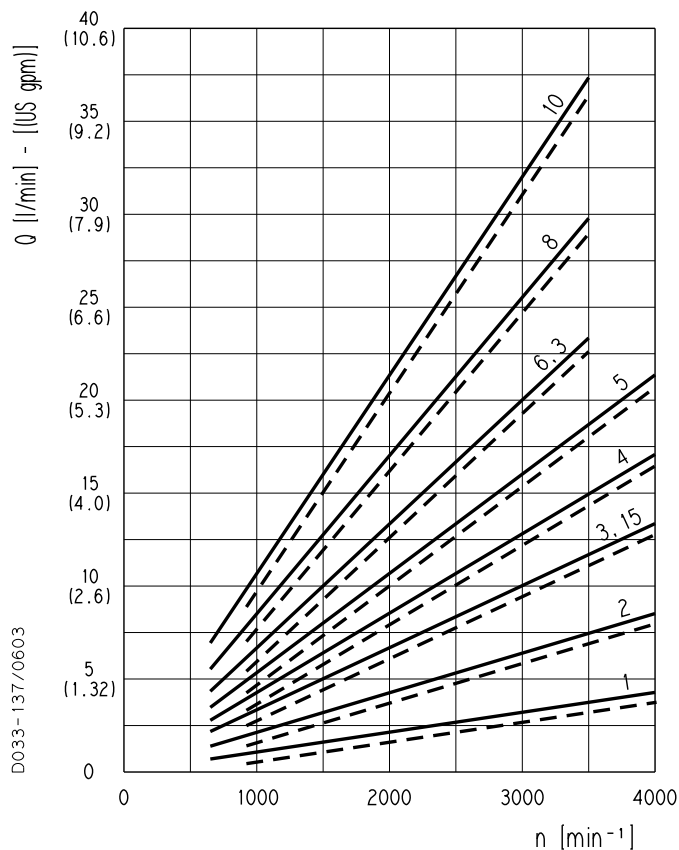

Each curve has been obtained at 50 °C (122 °F), using oil with viscosity 46 cSt (210 SSU) at 40 °C (104 °F) and at these pressures.

| | | |
|--------------------|---------|--------------------|
| PLP 10•1 | ———— | 20 bar (290 psi) |
| | - - - - | 260 bar (3770 psi) |
| PLP 10•2 | ———— | 20 bar (290 psi) |
| | - - - - | 260 bar (3770 psi) |
| PLP 10•3,15 | ———— | 20 bar (290 psi) |
| | - - - - | 260 bar (3770 psi) |
| PLP 10•4 | ———— | 20 bar (290 psi) |
| | - - - - | 250 bar (3625 psi) |
| PLP 10•5 | ———— | 20 bar (290 psi) |
| | - - - - | 250 bar (3625 psi) |
| PLP 10•6,3 | ———— | 20 bar (290 psi) |
| | - - - - | 230 bar (3335 psi) |
| PLP 10•8 | ———— | 20 bar (290 psi) |
| | - - - - | 180 bar (2610 psi) |
| PLP 10•10 | ———— | 20 bar (290 psi) |
| | - - - - | 140 bar (2030 psi) |

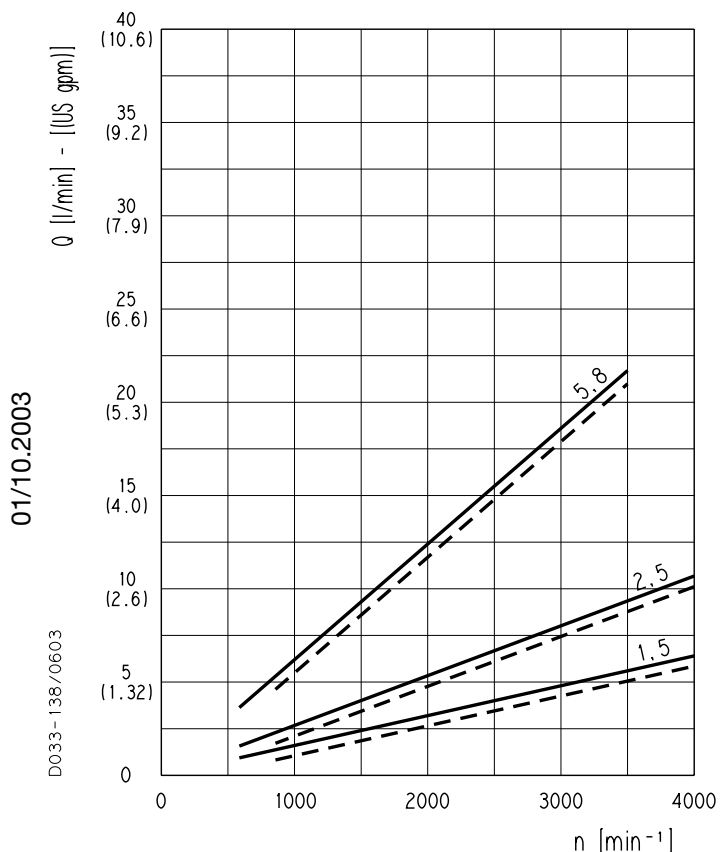

| | | |
|-------------------|---------|--------------------|
| PLP 10•1,5 | ———— | 20 bar (290 psi) |
| | - - - - | 260 bar (3770 psi) |
| PLP 10•2,5 | ———— | 20 bar (290 psi) |
| | - - - - | 260 bar (3770 psi) |
| PLP 10•5,8 | ———— | 20 bar (290 psi) |
| | - - - - | 230 bar (3335 psi) |

PLP 10

POLARIS 10 GEAR PUMPS PERFORMANCE CURVES

PLP 10•1

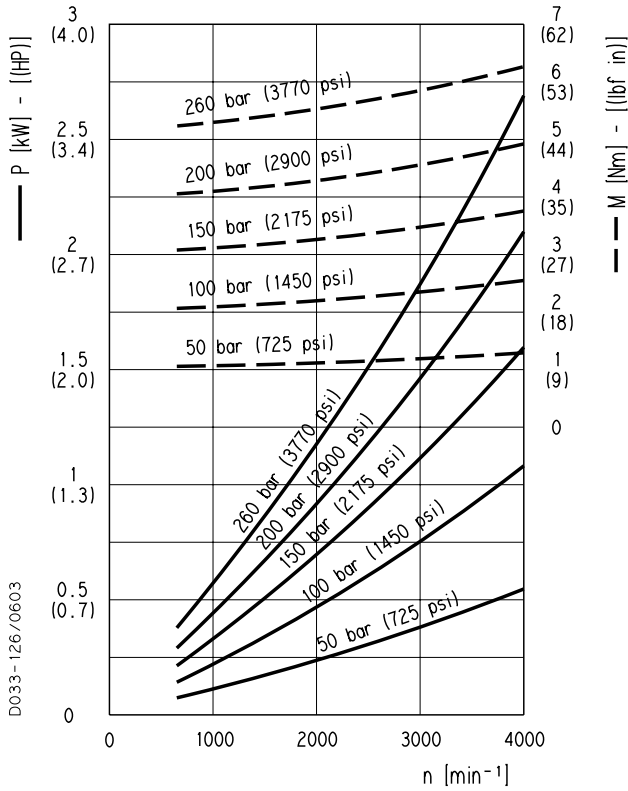

PLP 10•1,5

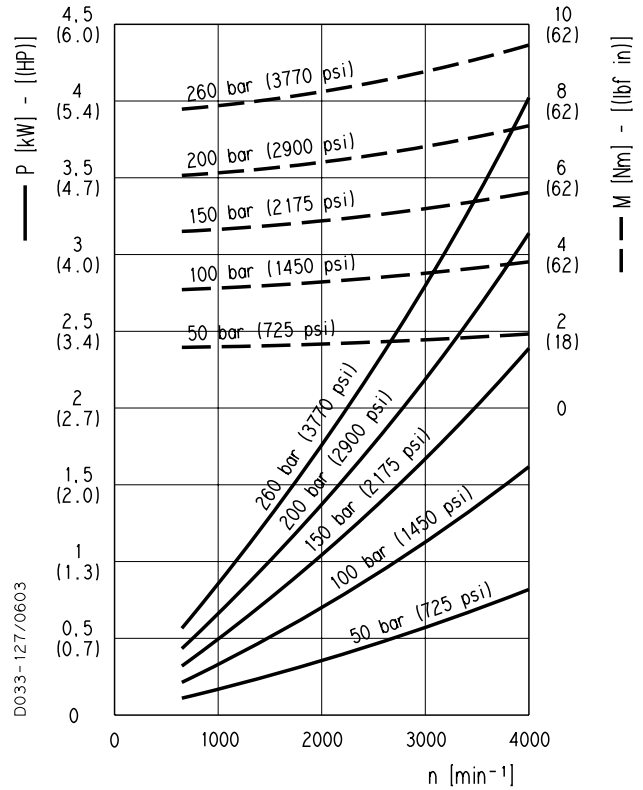

PLP 10•2

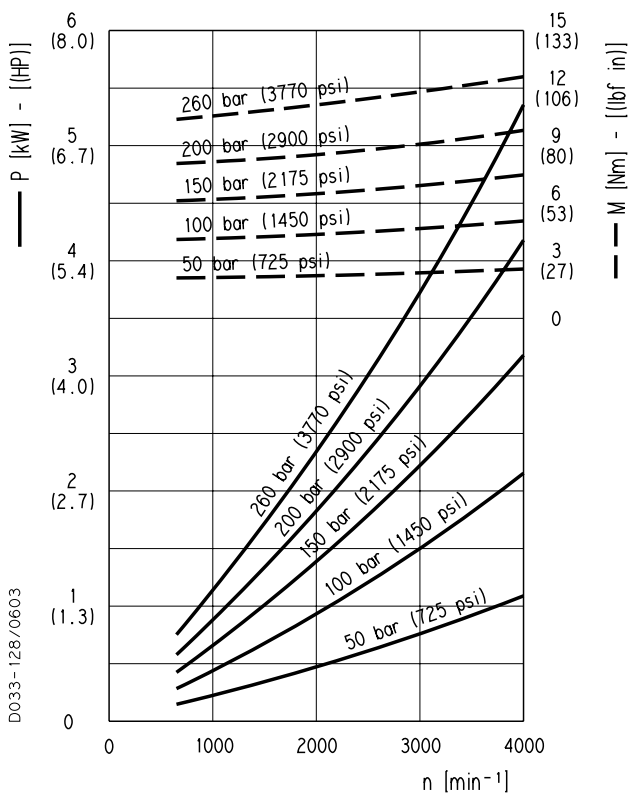

PLP 10•2,5

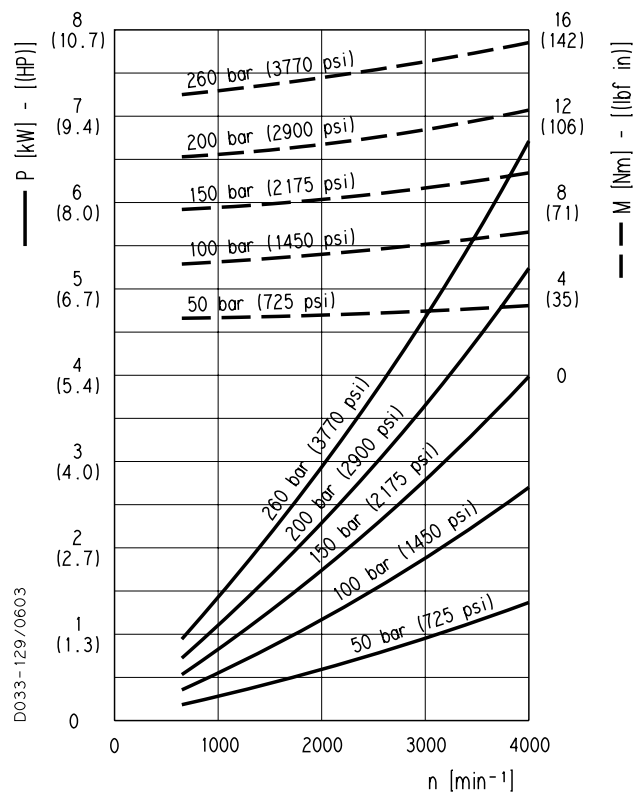

01/10.2003

PLP 10

POLARIS 10 GEAR PUMPS PERFORMANCE CURVES

PLP 10•3,15

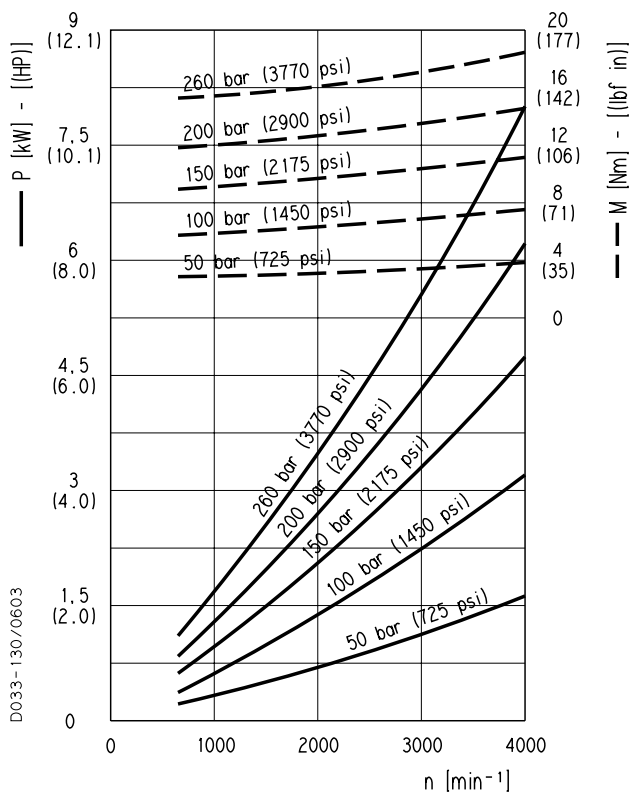

PLP 10•4

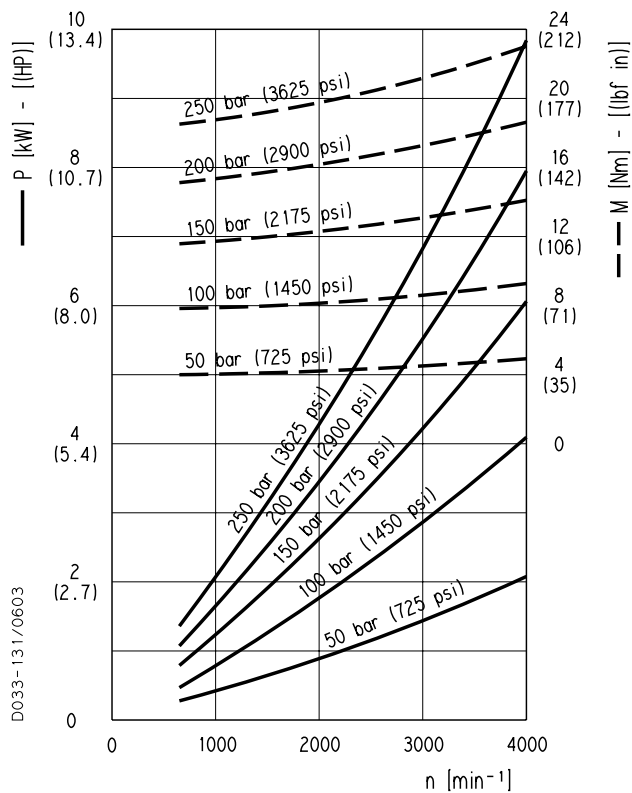

PLP 10•5

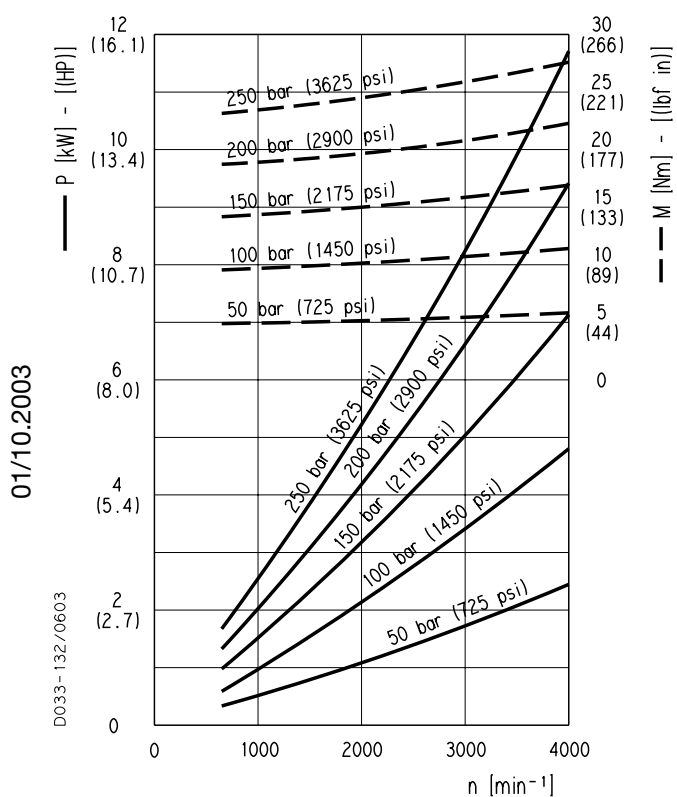

PLP 10•5,8

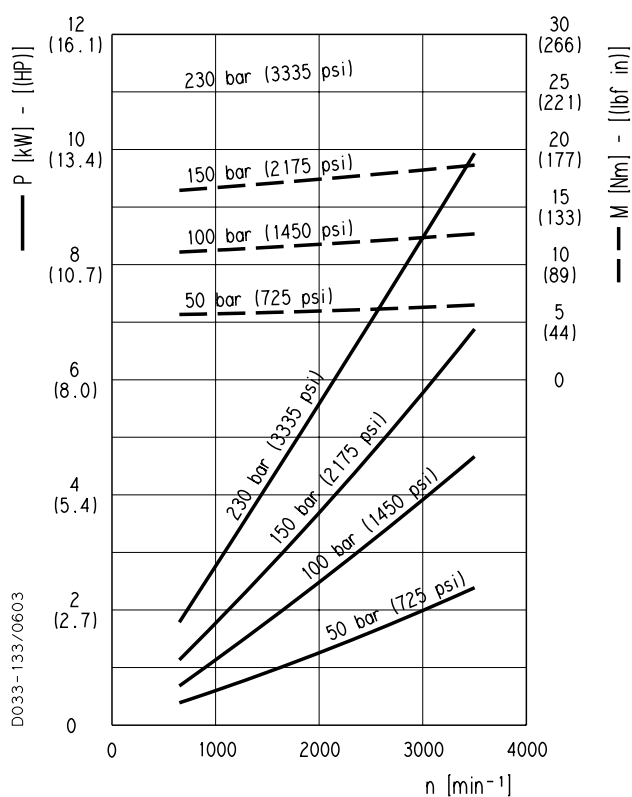

PLP 10

POLARIS 10 GEAR PUMPS PERFORMANCE CURVES

PLP 10•6,3

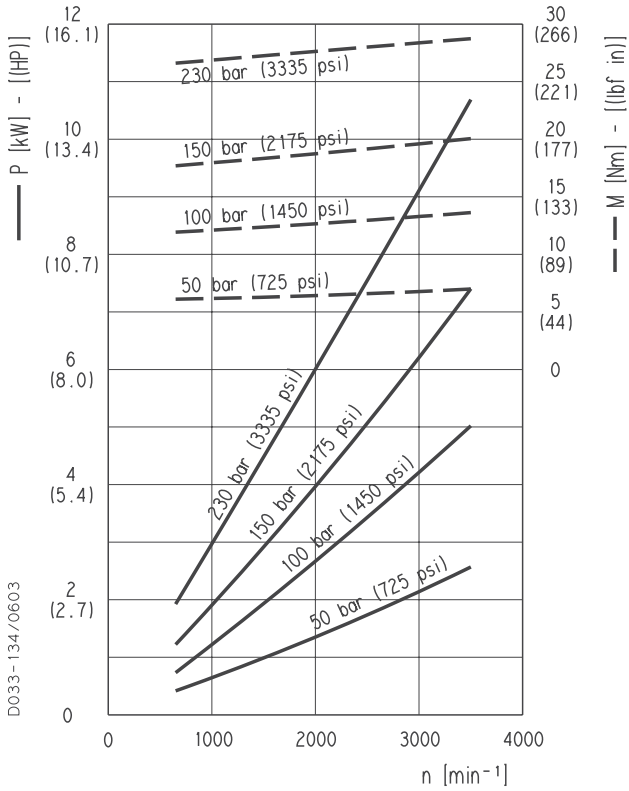

PLP 10•8

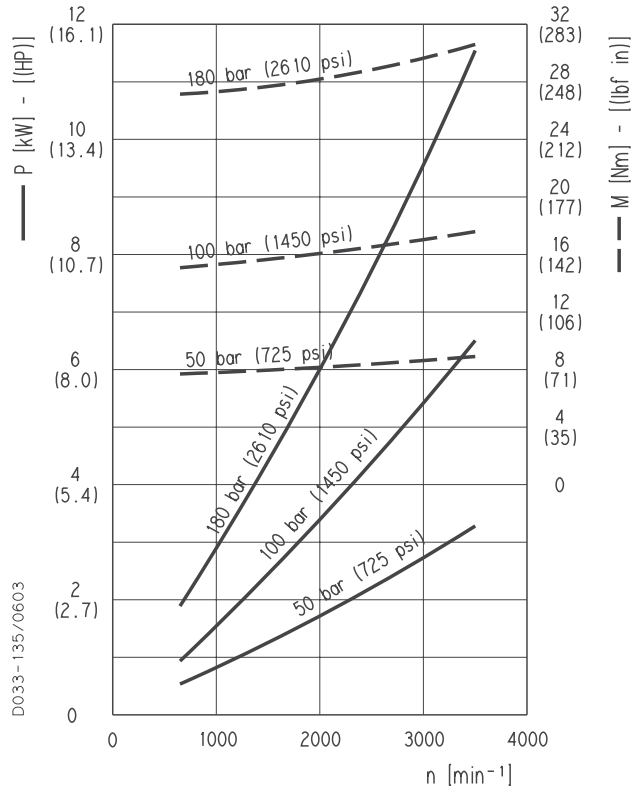

PLP 10•10

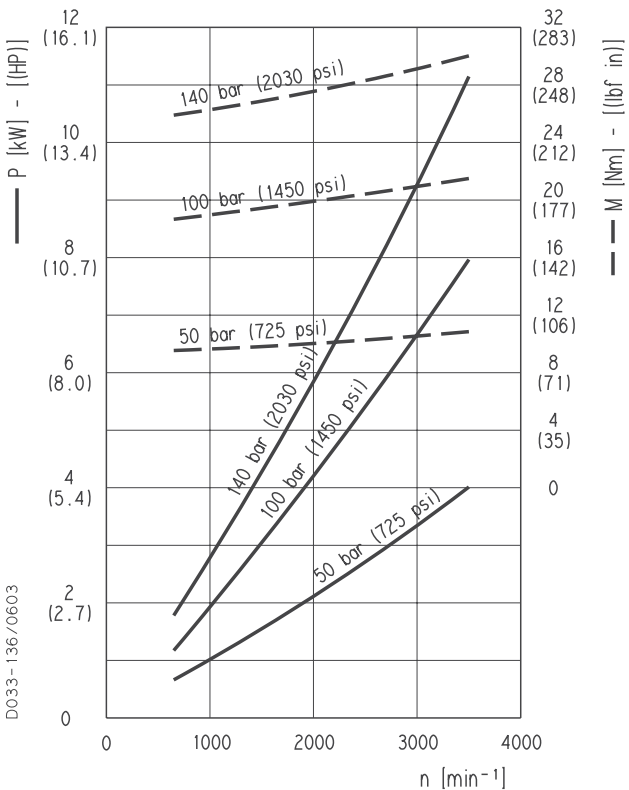

01/10.2003

PLP 20

POLARIS 20 GEAR PUMPS PERFORMANCE CURVES

PLP 20

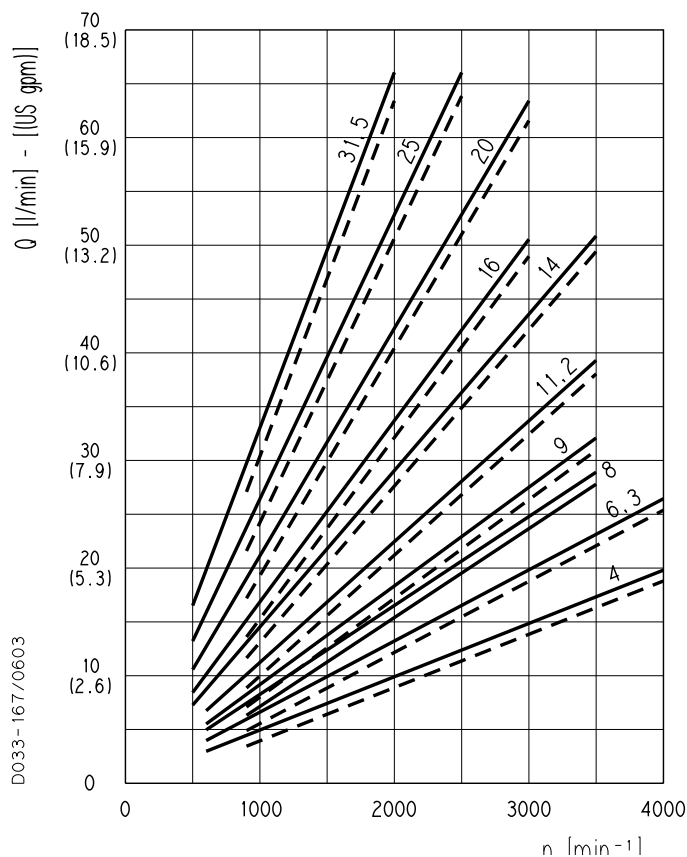

Each curve has been obtained at 50 °C (122 °F), using oil with viscosity 46 cSt (210 SSU) at 40 °C (104 °F) and at these pressures.

| | | |
|--------------------|-------|--------------------|
| PLP 20•4 | — | 20 bar (290 psi) |
| | - - - | 250 bar (3625 psi) |
| PLP 20•6,3 | — | 20 bar (290 psi) |
| | - - - | 250 bar (3625 psi) |
| PLP 20•8 | — | 20 bar (290 psi) |
| | - - - | 250 bar (3625 psi) |
| PLP 20•9 | — | 20 bar (290 psi) |
| | - - - | 250 bar (3625 psi) |
| PLP 20•11,2 | — | 20 bar (290 psi) |
| | - - - | 250 bar (3625 psi) |
| PLP 20•14 | — | 20 bar (290 psi) |
| | - - - | 250 bar (3625 psi) |
| PLP 20•16 | — | 20 bar (290 psi) |
| | - - - | 250 bar (3625 psi) |
| PLP 20•20 | — | 20 bar (290 psi) |
| | - - - | 200 bar (2900 psi) |
| PLP 20•25 | — | 20 bar (290 psi) |
| | - - - | 170 bar (2465 psi) |
| PLP 20•31,5 | — | 20 bar (290 psi) |
| | - - - | 130 bar (1885 psi) |
| PLP 20•7,2 | — | 20 bar (290 psi) |
| | - - - | 250 bar (3625 psi) |
| PLP 20•10,5 | — | 20 bar (290 psi) |
| | - - - | 250 bar (3625 psi) |
| PLP 20•19 | — | 20 bar (290 psi) |
| | - - - | 200 bar (2900 psi) |
| PLP 20•24,5 | — | 20 bar (290 psi) |
| | - - - | 270 bar (2465 psi) |
| PLP 20•27,8 | — | 20 bar (290 psi) |
| | - - - | 130 bar (1885 psi) |

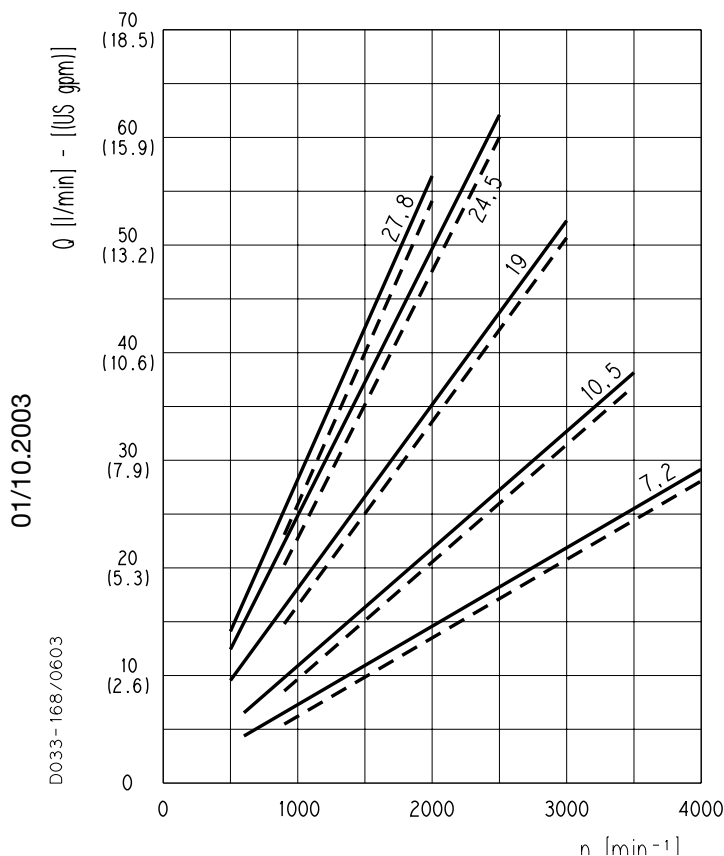

PLP 20

POLARIS 20 GEAR PUMPS PERFORMANCE CURVES

PLP 20•4

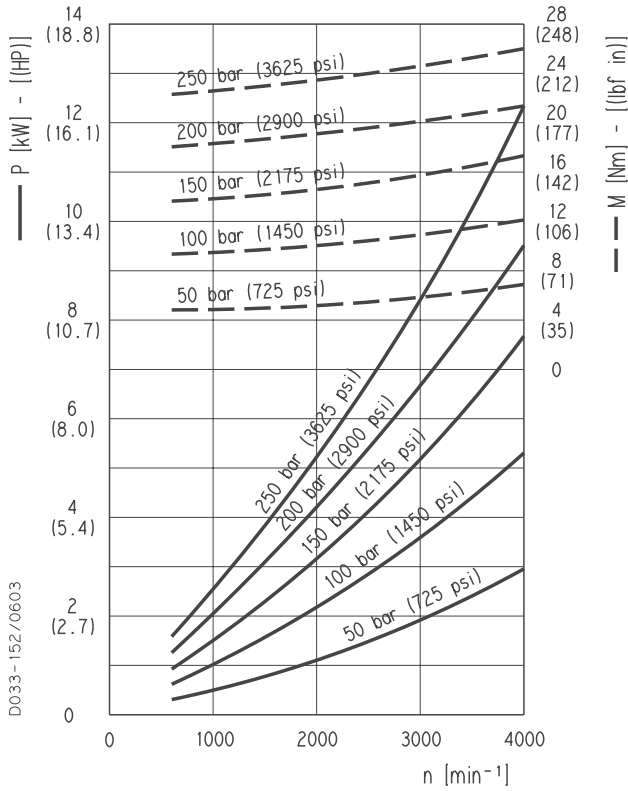

PLP 20•6,3

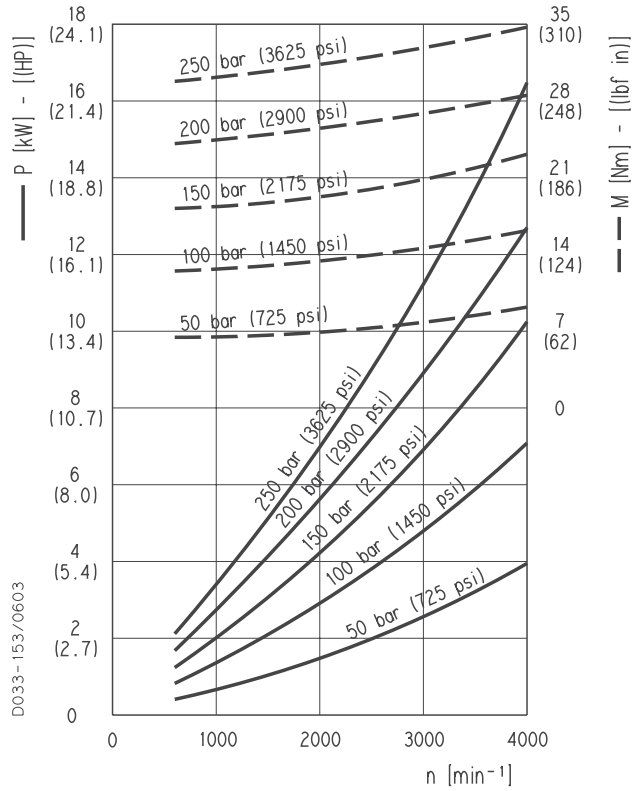

PLP 20•7,2

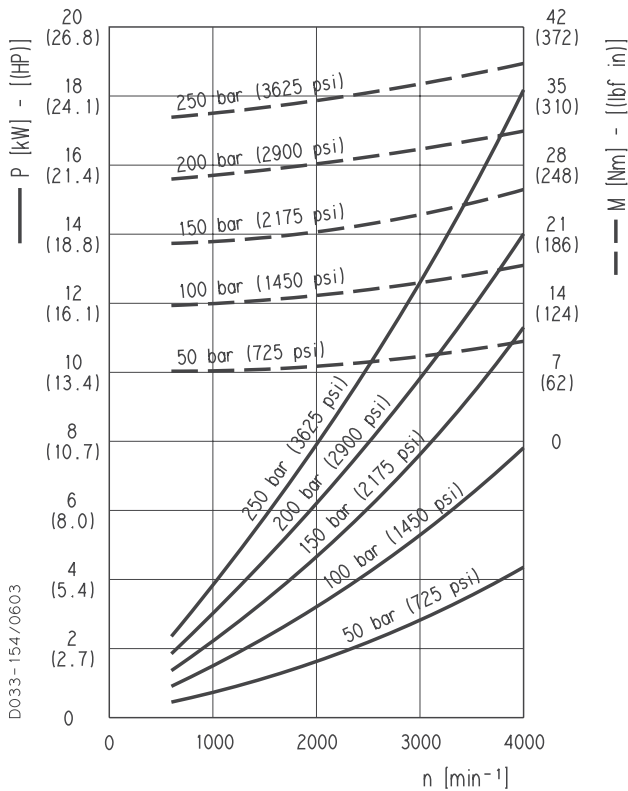

PLP 20•8

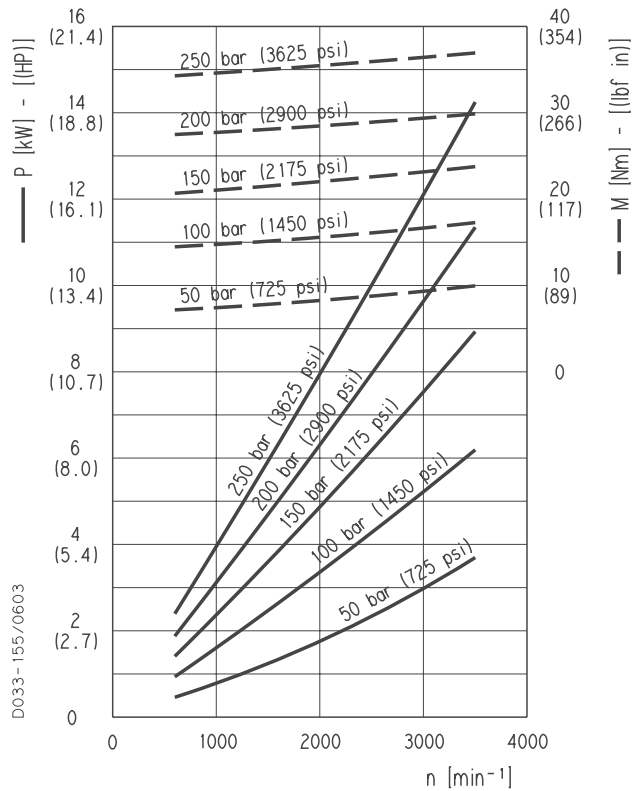

01/10.2003

PLP 20

POLARIS 20 GEAR PUMPS PERFORMANCE CURVES

PLP 20•9

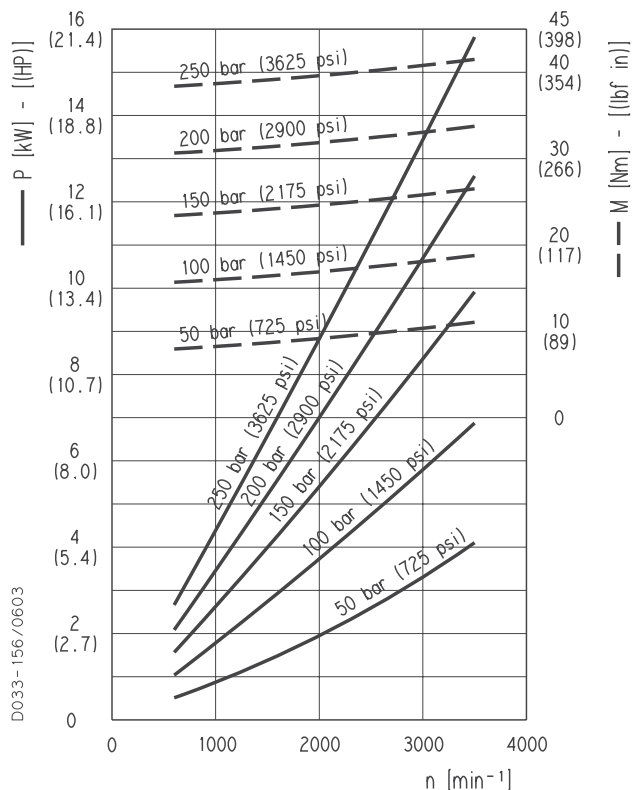

PLP 20•10,5

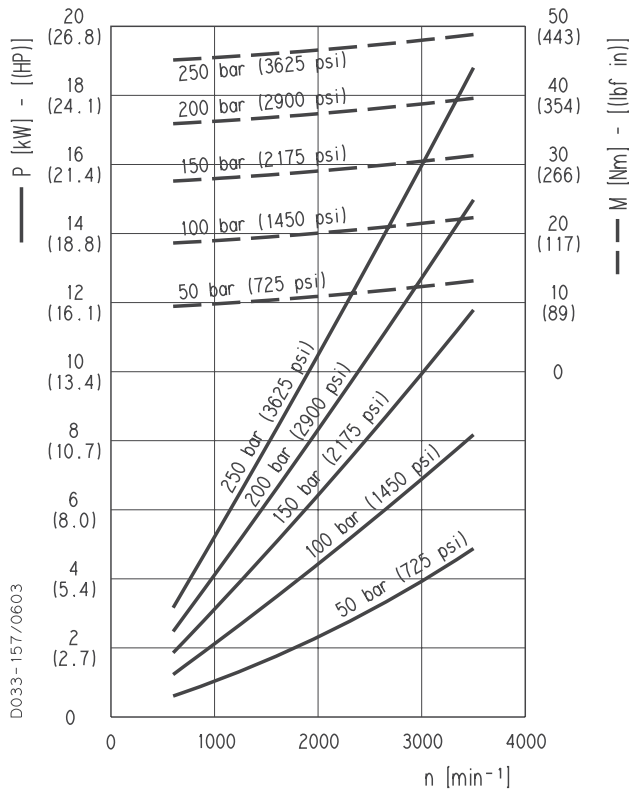

PLP 20•11,2

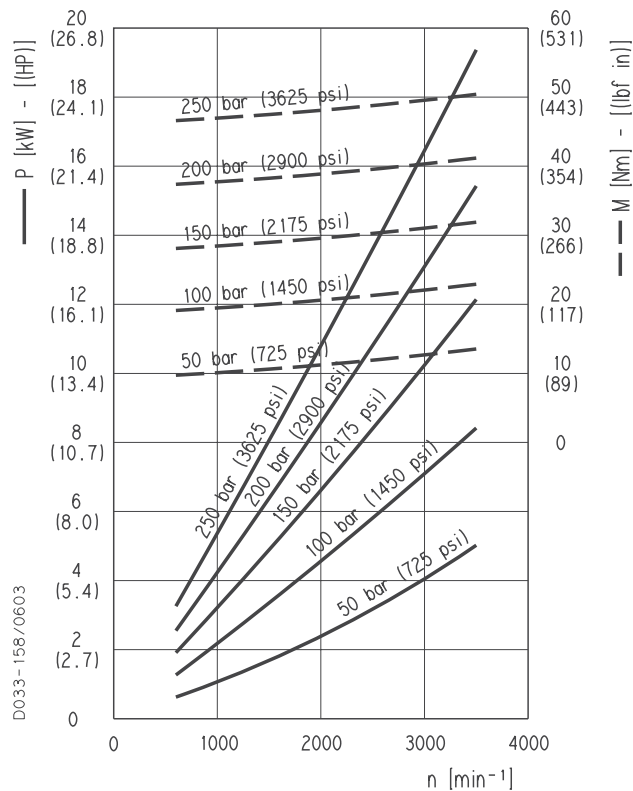

PLP 20•14

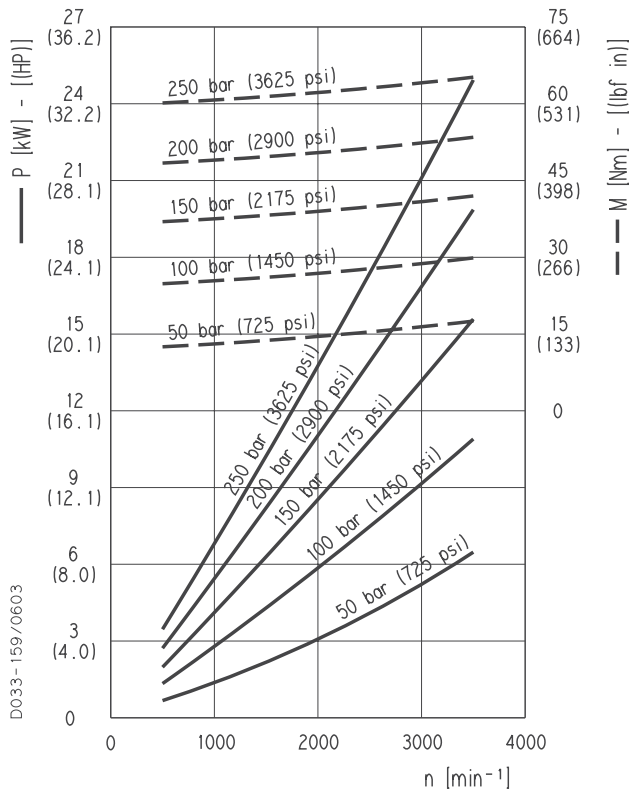

01/10.2003

PLP 20

POLARIS 20 GEAR PUMPS PERFORMANCE CURVES

PLP 20•16

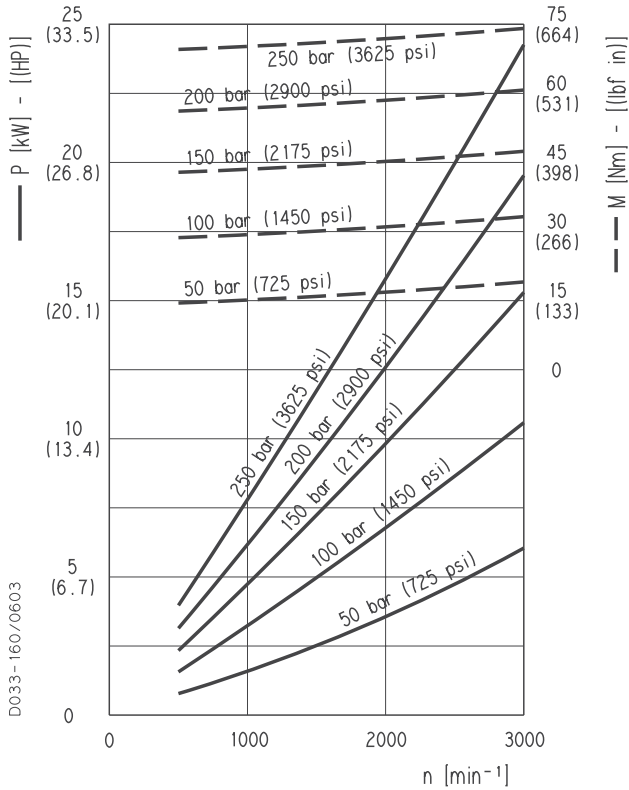

PLP 20•19

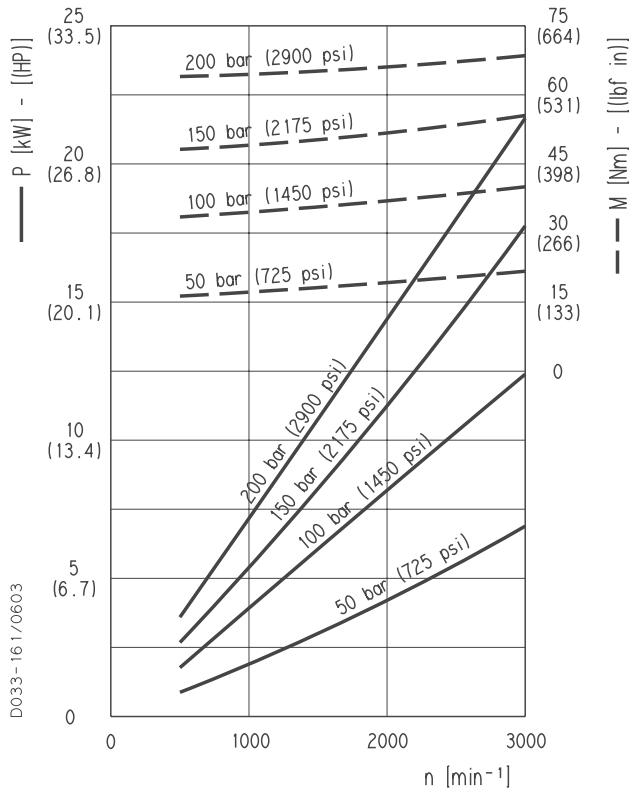

PLP 20•20

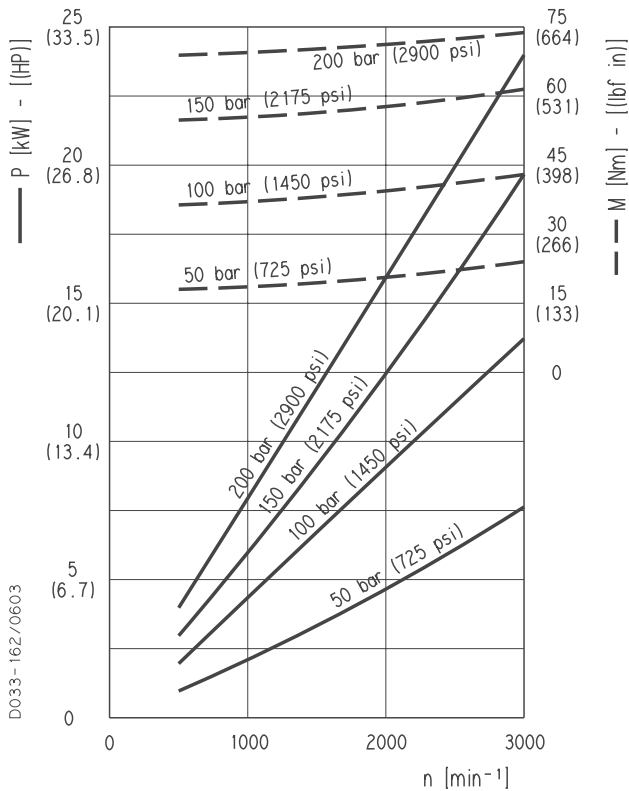

PLP 20•24,5

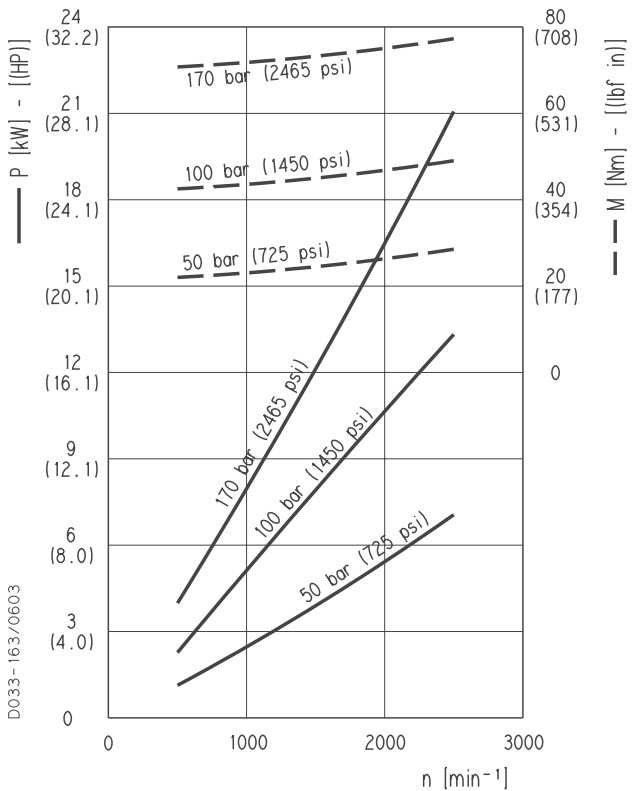

01/10.2003

PLP 20

POLARIS 20 GEAR PUMPS PERFORMANCE CURVES

PLP 20•25

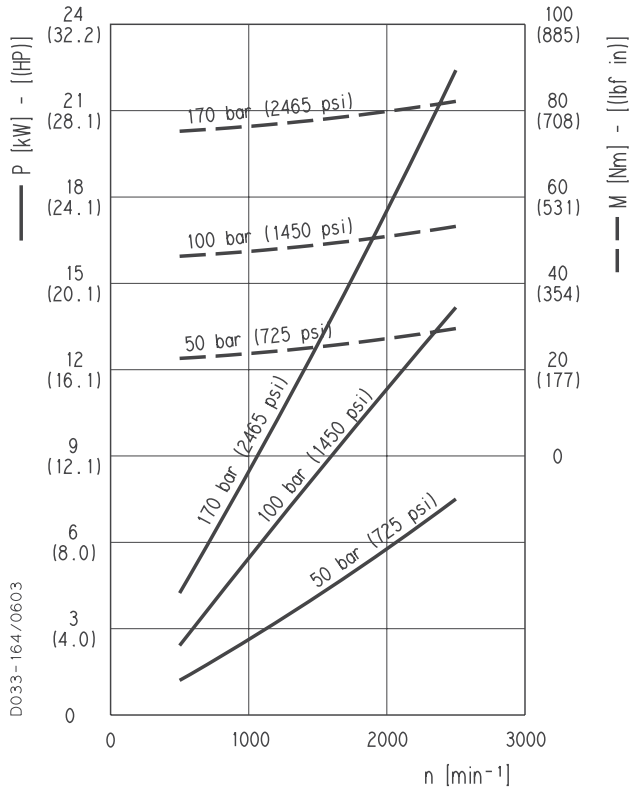

PLP 20•27,8

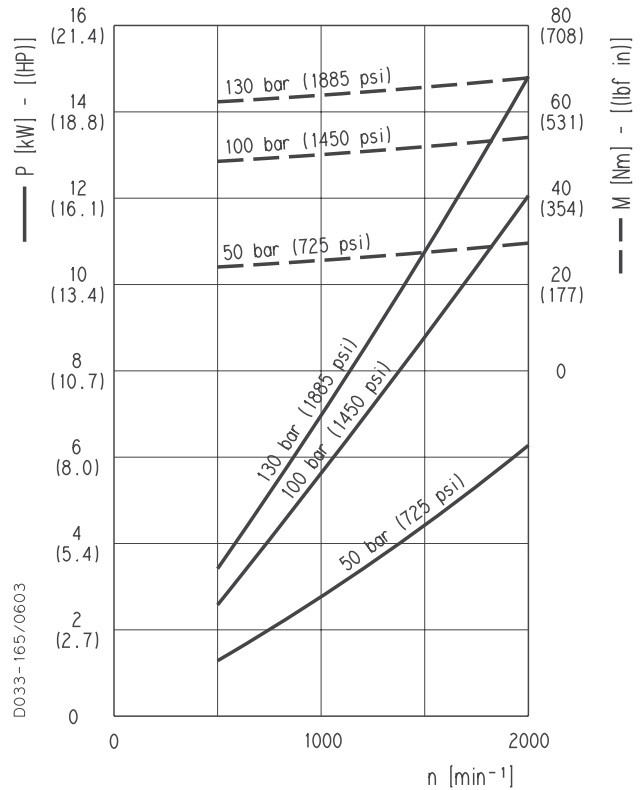

PLP 20•31,5

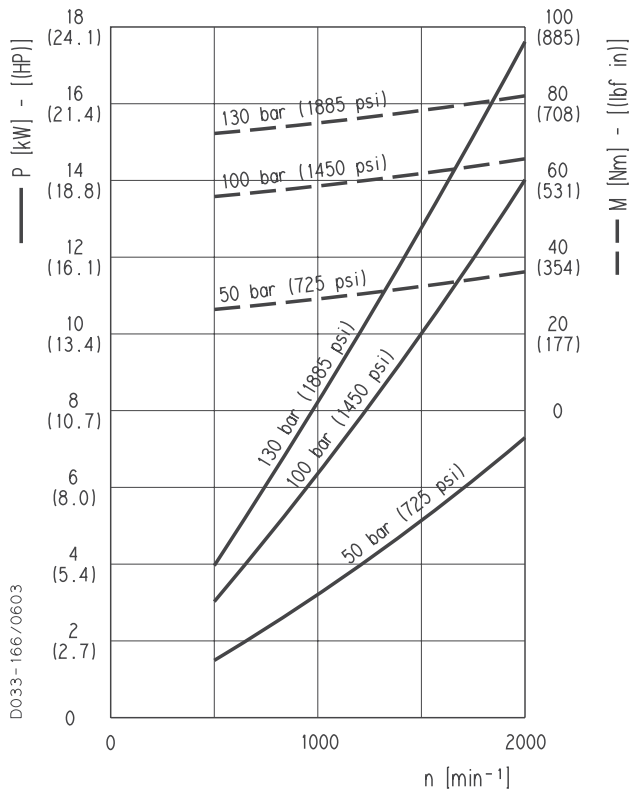

01/10.2003

PLP 30

POLARIS 30 GEAR PUMPS PERFORMANCE CURVES

Each curve has been obtained at 50 °C (122 °F), using oil with viscosity 46 cSt (210 SSU) at 40 °C (104 °F) and at these pressures.

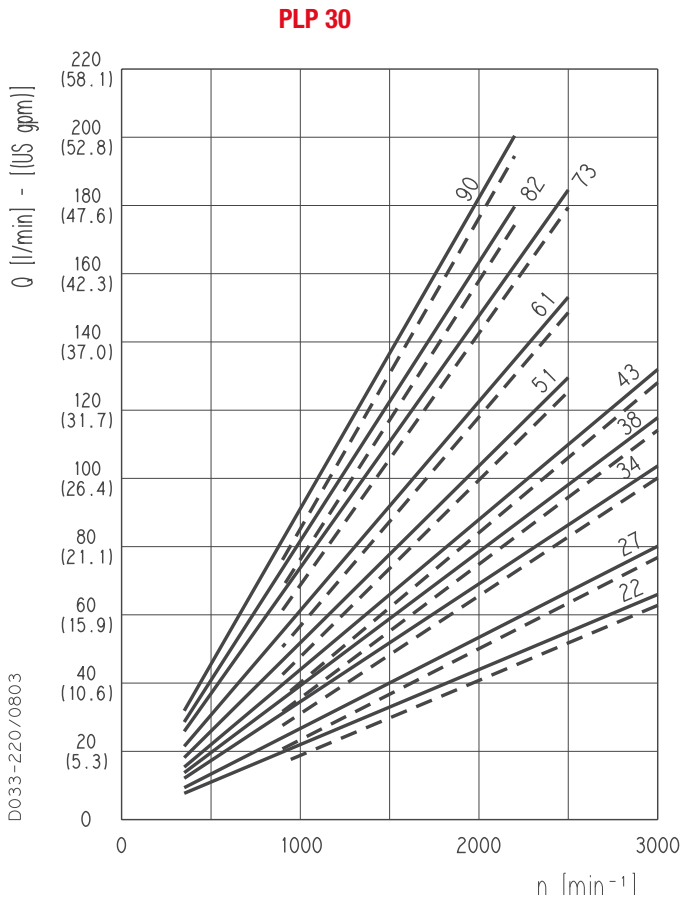

| | | |
|------------------|---------|--------------------|
| PLP 30•22 | ———— | 20 bar (290 psi) |
| | - - - - | 250 bar (3625 psi) |
| PLP 30•27 | ———— | 20 bar (290 psi) |
| | - - - - | 250 bar (3625 psi) |
| PLP 30•34 | ———— | 20 bar (290 psi) |
| | - - - - | 240 bar (3480 psi) |
| PLP 30•38 | ———— | 20 bar (290 psi) |
| | - - - - | 240 bar (3480 psi) |
| PLP 30•43 | ———— | 20 bar (290 psi) |
| | - - - - | 230 bar (3335 psi) |
| PLP 30•51 | ———— | 20 bar (290 psi) |
| | - - - - | 210 bar (3045 psi) |
| PLP 30•61 | ———— | 20 bar (290 psi) |
| | - - - - | 190 bar (2775 psi) |
| PLP 30•73 | ———— | 20 bar (290 psi) |
| | - - - - | 170 bar (2465 psi) |
| PLP 30•82 | ———— | 20 bar (290 psi) |
| | - - - - | 160 bar (2320 psi) |
| PLP 30•90 | ———— | 20 bar (290 psi) |
| | - - - - | 150 bar (2175 psi) |

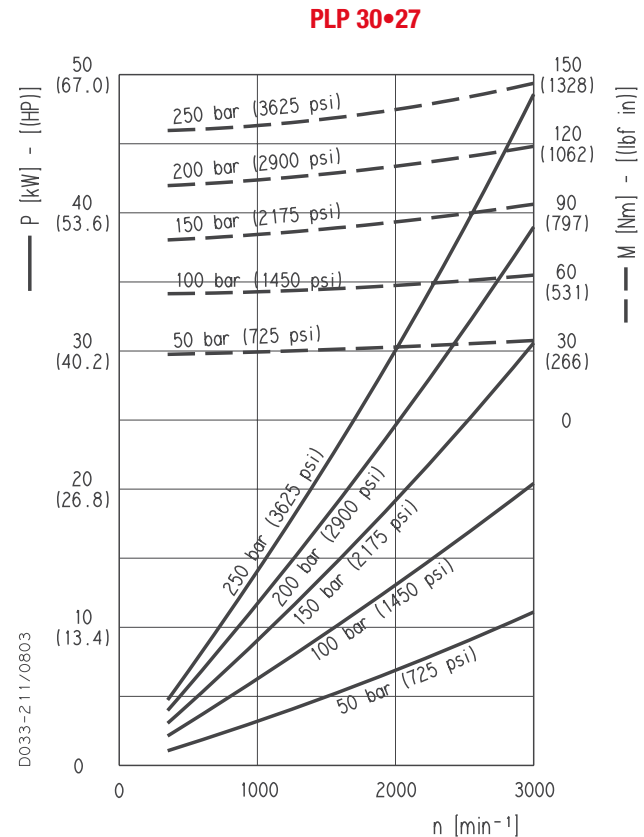
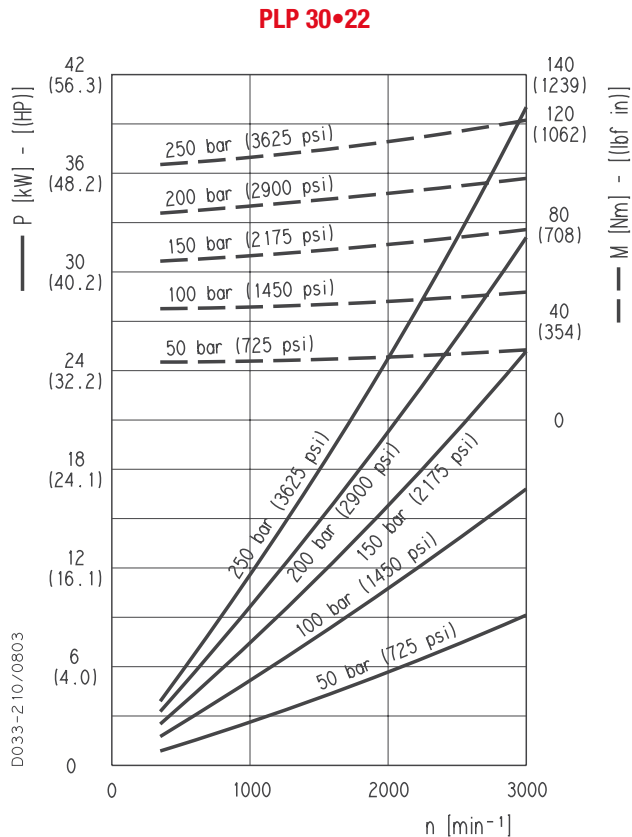

01/10.2003

PLP 30

POLARIS 30 GEAR PUMPS PERFORMANCE CURVES

PLP 30•34

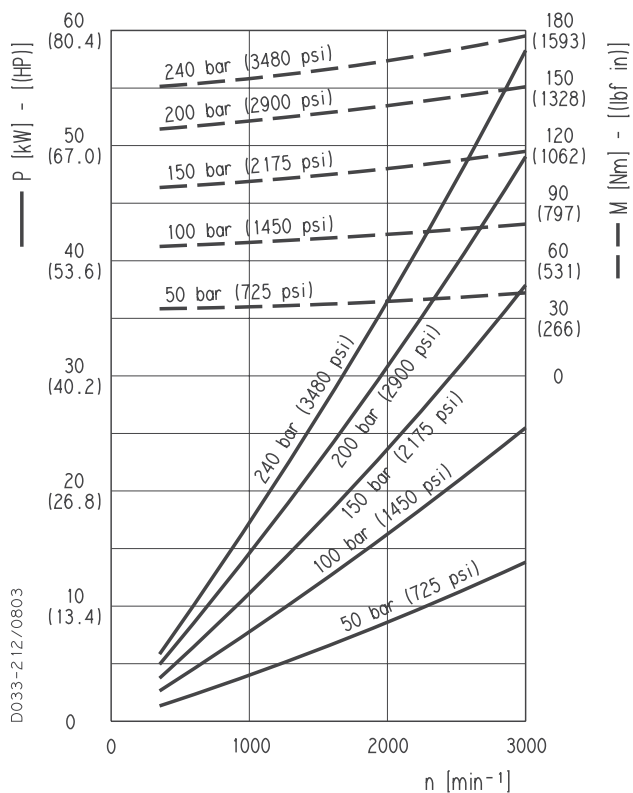

PLP 30•38

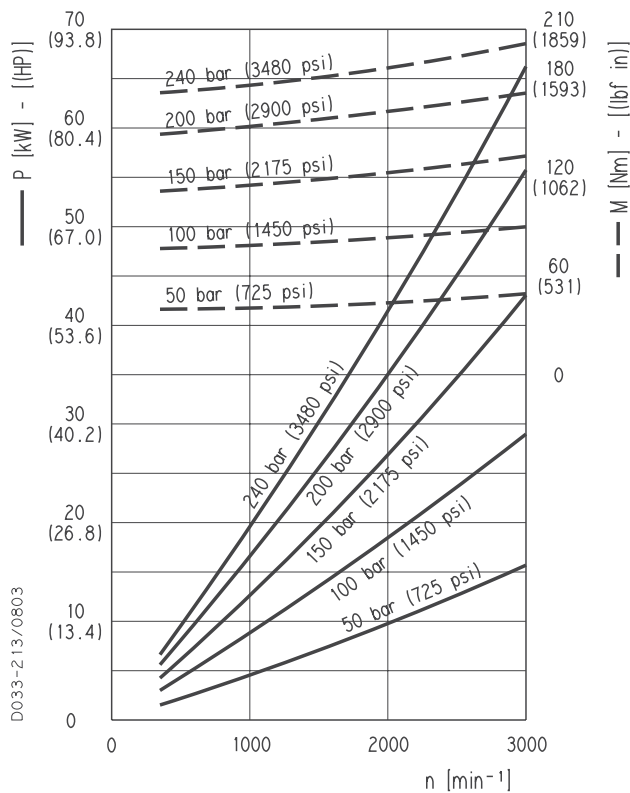

PLP 30•43

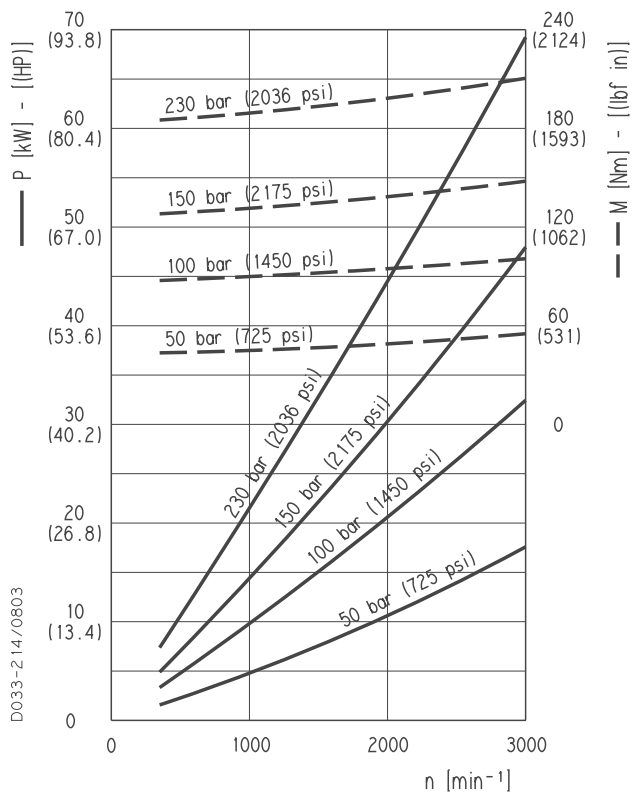

PLP 30•51

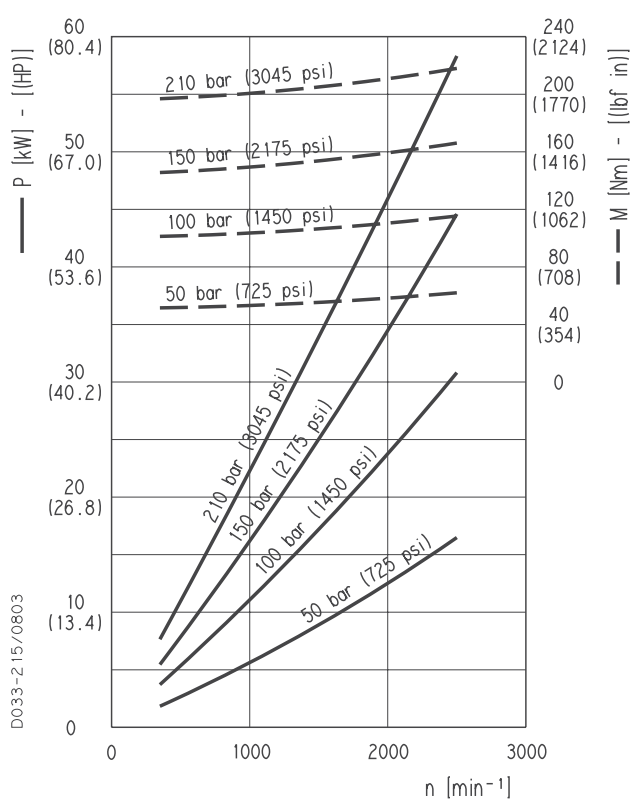

01/10.2003

PLP 30

POLARIS 30 GEAR PUMPS PERFORMANCE CURVES

PLP 30•61

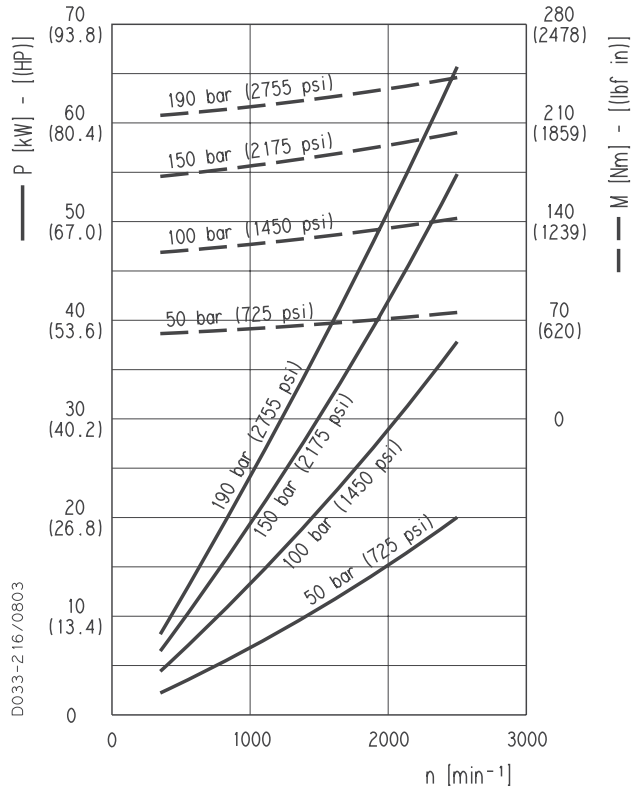

PLP 30•73

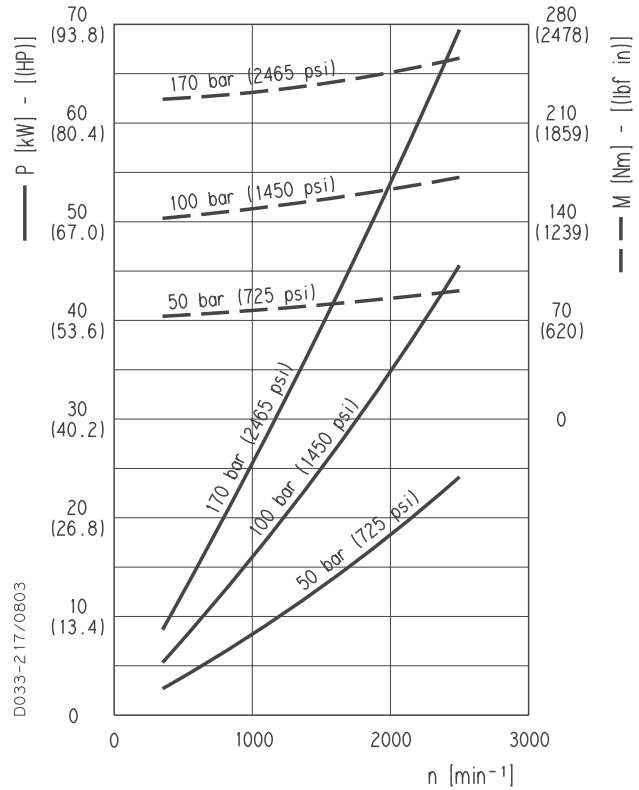

PLP 30•82

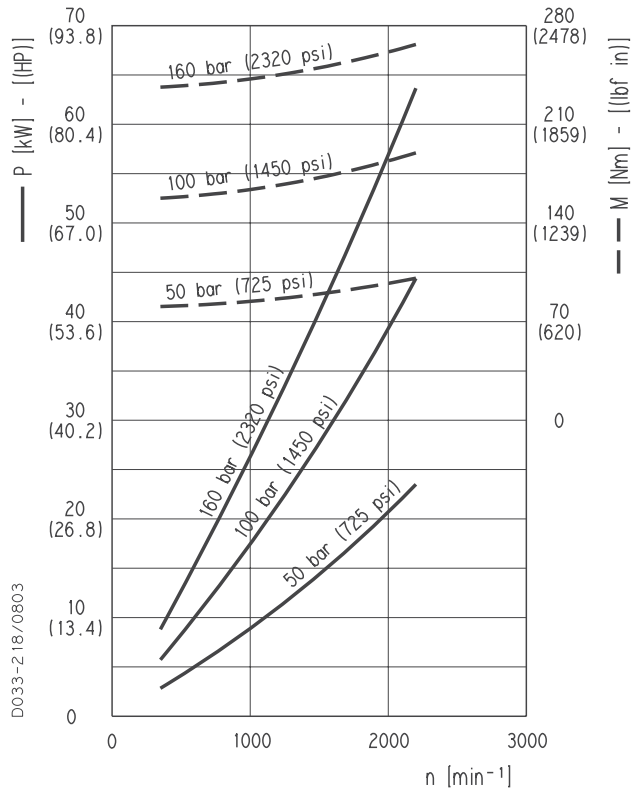

PLP 30•90

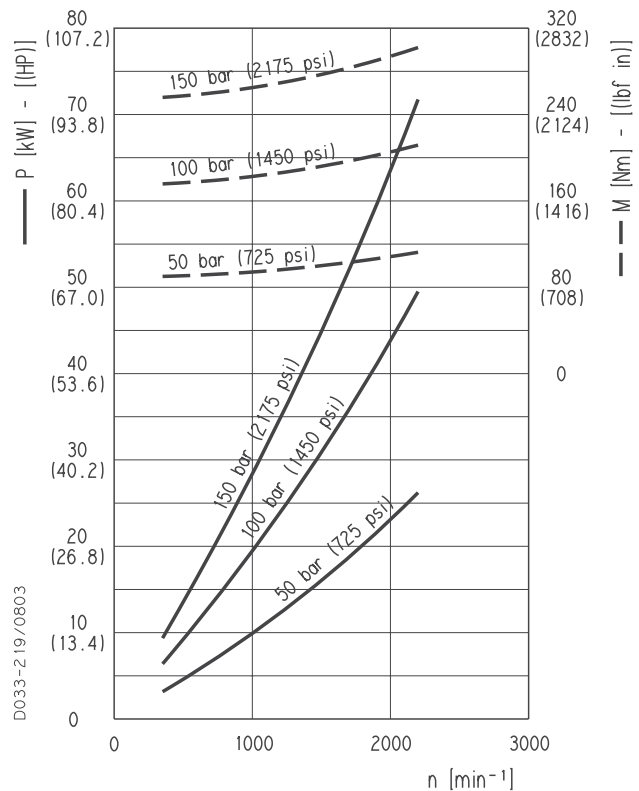

01/10.2003

PLM 10

POLARIS 10 GEAR MOTORS PERFORMANCE CURVES

PLM 10

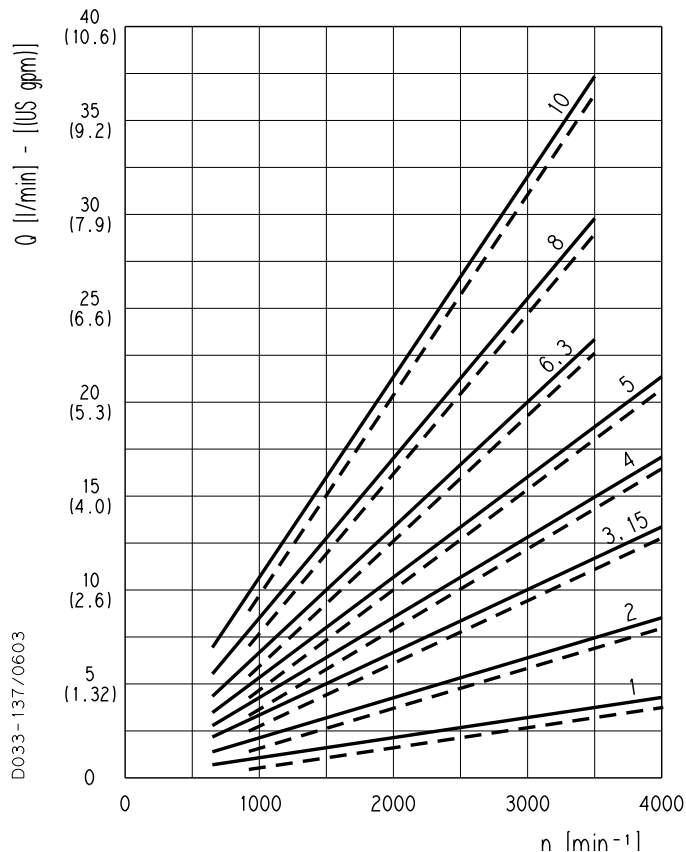

Each curve has been obtained at 50 °C (122 °F), using oil with viscosity 46 cSt (210 SSU) at 40 °C (104 °F) and at these pressures.

| | | |
|--------------------|-------|--------------------|
| PLM 10•1 | — | 20 bar (290 psi) |
| | - - - | 260 bar (3770 psi) |
| PLM 10•2 | — | 20 bar (290 psi) |
| | - - - | 260 bar (3770 psi) |
| PLM 10•3,15 | — | 20 bar (290 psi) |
| | - - - | 260 bar (3770 psi) |
| PLM 10•4 | — | 20 bar (290 psi) |
| | - - - | 250 bar (3625 psi) |
| PLM 10•5 | — | 20 bar (290 psi) |
| | - - - | 250 bar (3625 psi) |
| PLM 10•6,3 | — | 20 bar (290 psi) |
| | - - - | 230 bar (3335 psi) |
| PLM 10•8 | — | 20 bar (290 psi) |
| | - - - | 180 bar (2610 psi) |
| PLM 10•10 | — | 20 bar (290 psi) |
| | - - - | 140 bar (2030 psi) |

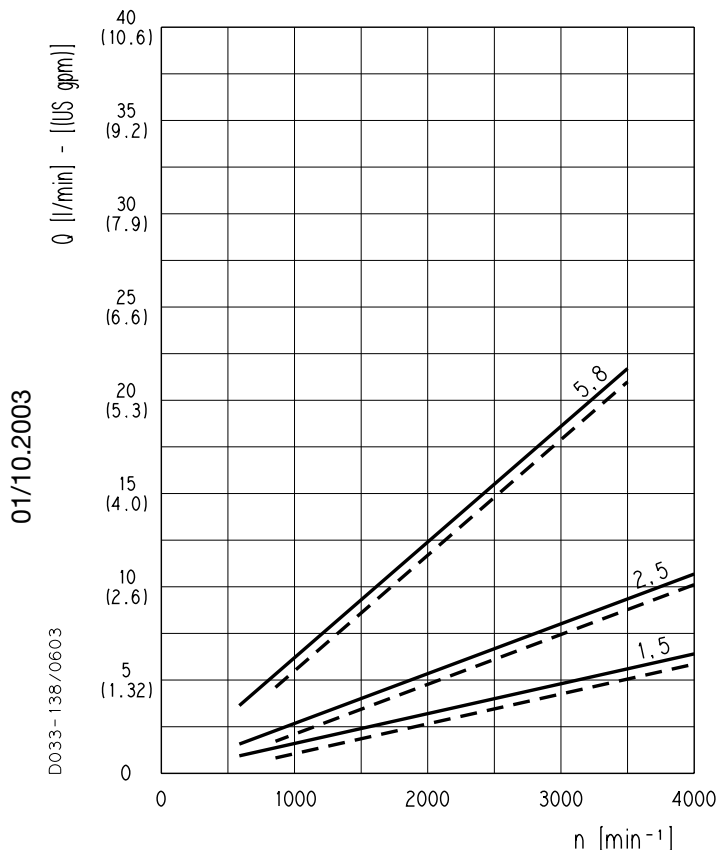

| | | |
|-------------------|-------|--------------------|
| PLM 10•1,5 | — | 20 bar (290 psi) |
| | - - - | 260 bar (3770 psi) |
| PLM 10•2,5 | — | 20 bar (290 psi) |
| | - - - | 260 bar (3770 psi) |
| PLM 10•5,8 | — | 20 bar (290 psi) |
| | - - - | 230 bar (3335 psi) |

PLM 10

POLARIS 10 GEAR MOTORS PERFORMANCE CURVES

PLM 10•1

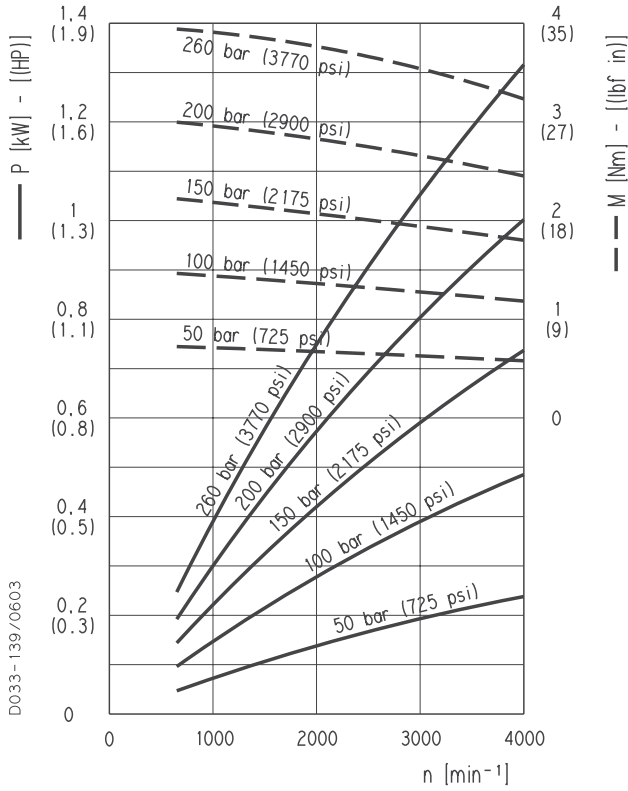

PLM 10•1,5

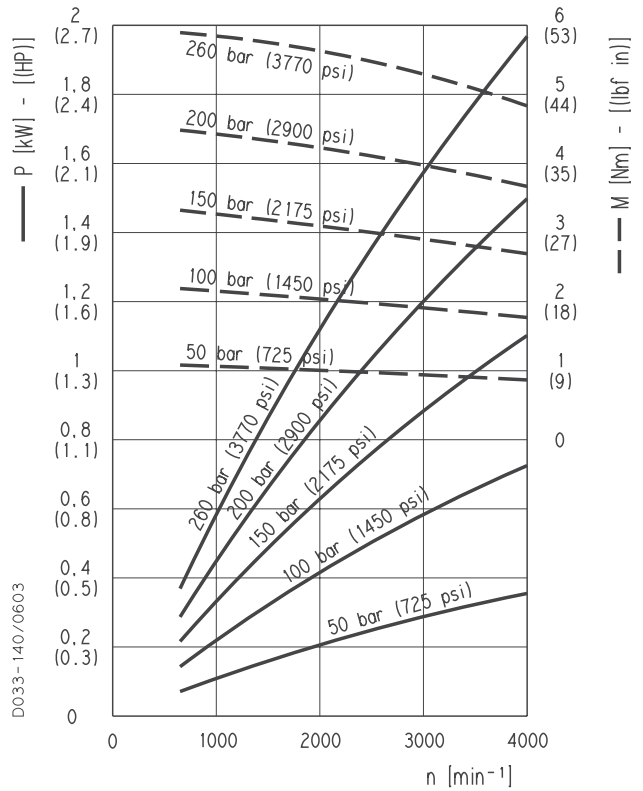

PLM 10•2

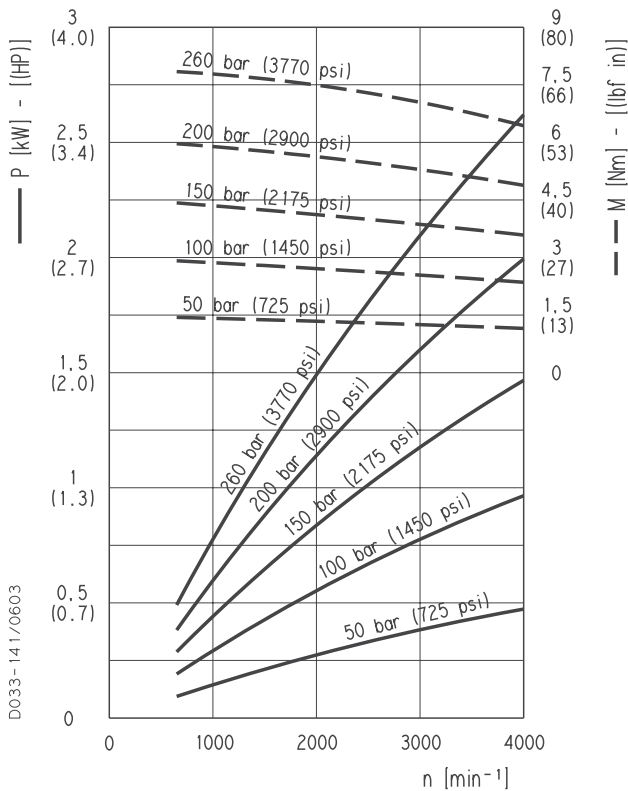

PLM 10•2,5

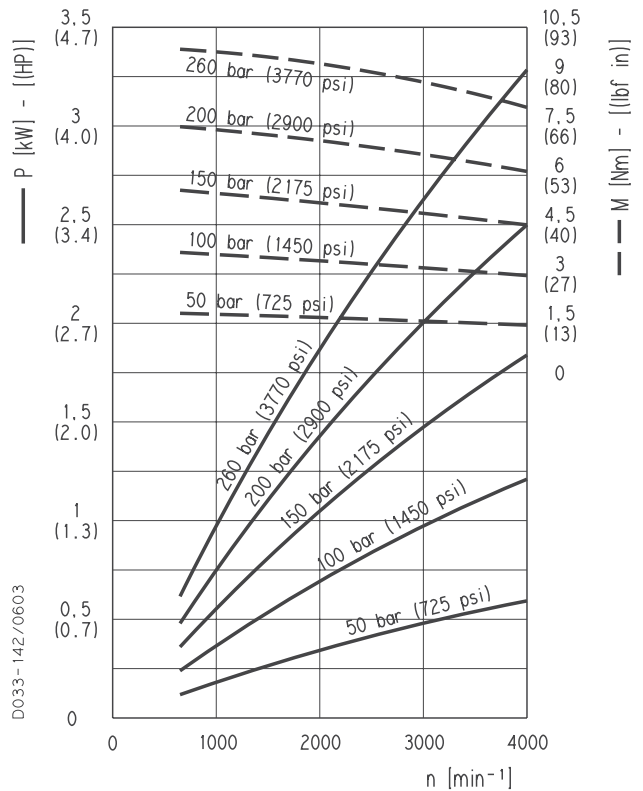

01/10.2003

PLM 10

POLARIS 10 GEAR MOTORS PERFORMANCE CURVES

PLM 10•3,15

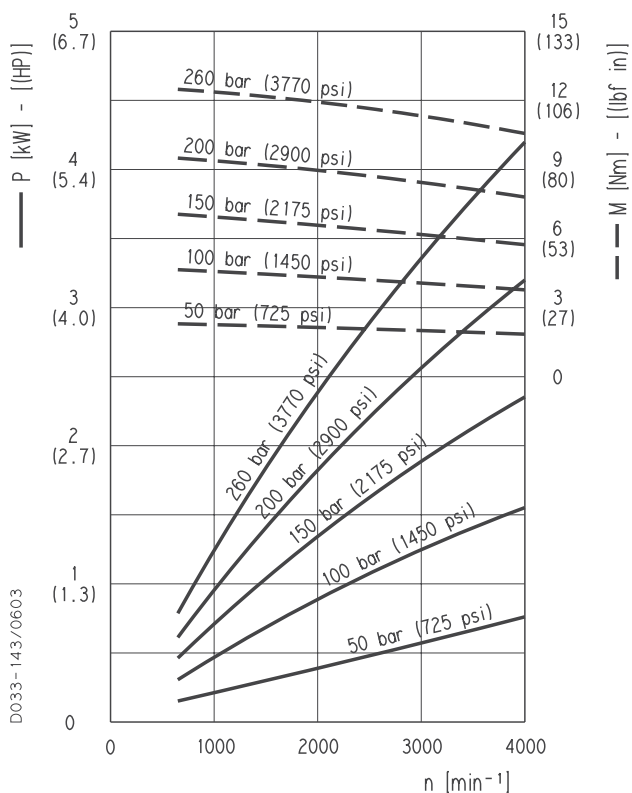

PLM 10•4

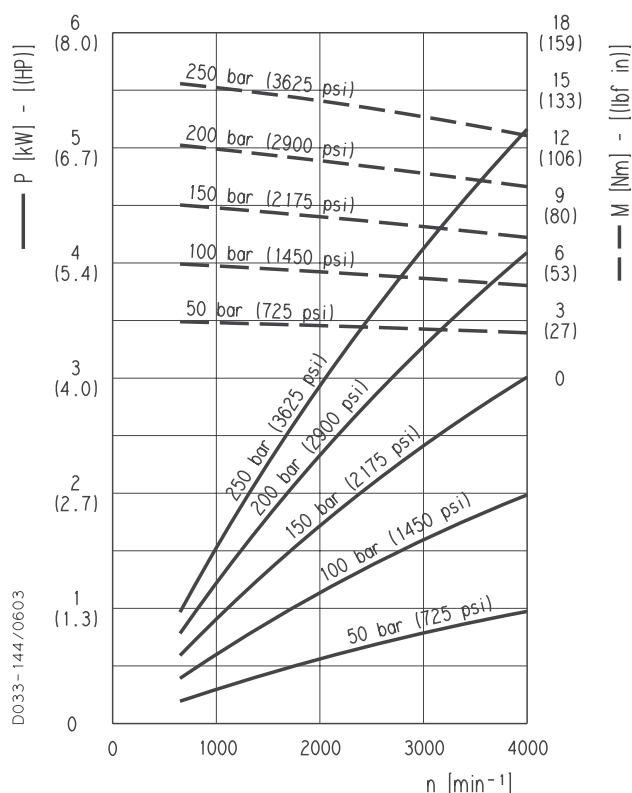

PLM 10•5

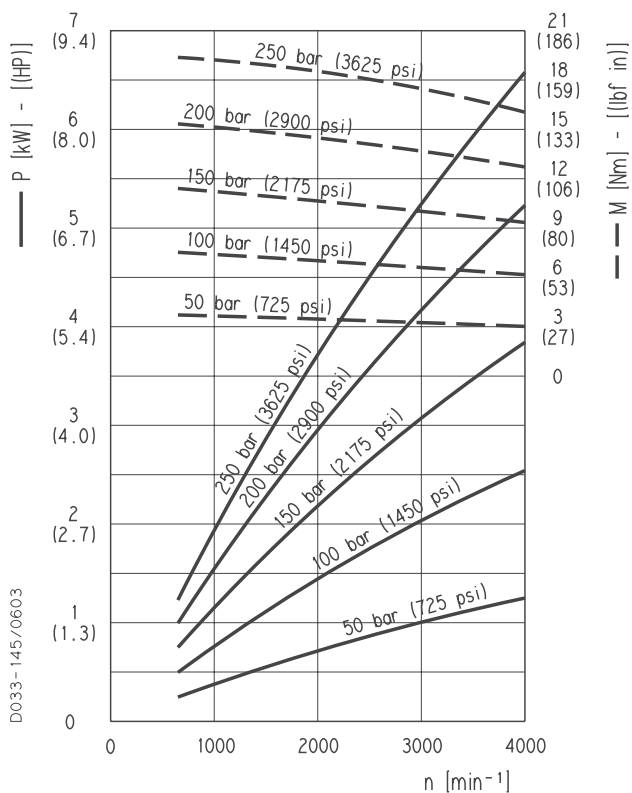

PLM 10•5,8

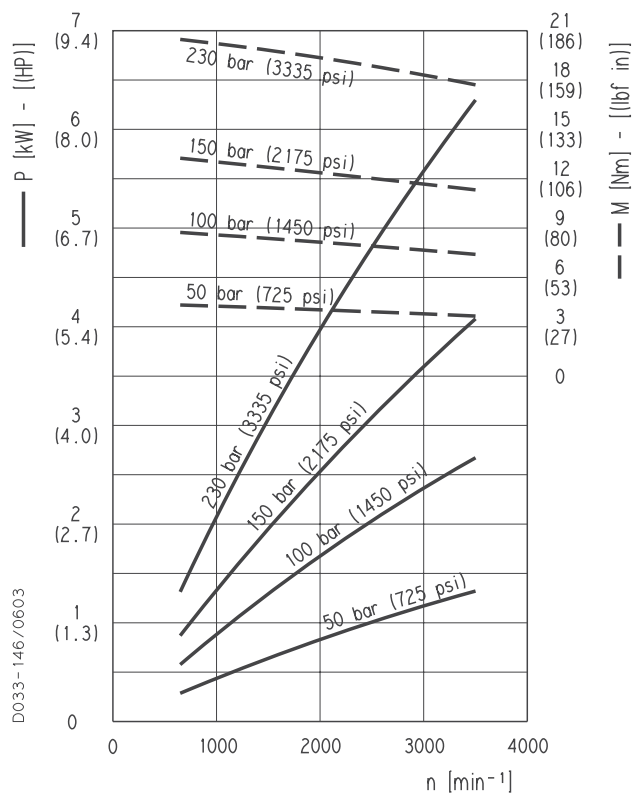

01/10.2003

PLM 10

POLARIS 10 GEAR MOTORS PERFORMANCE CURVES

PLM 10•6,3

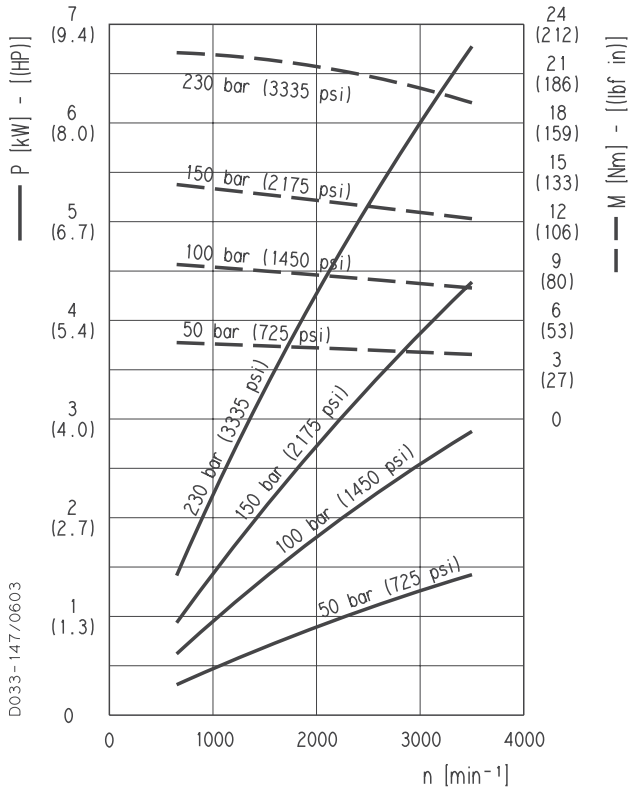

PLM 10•8

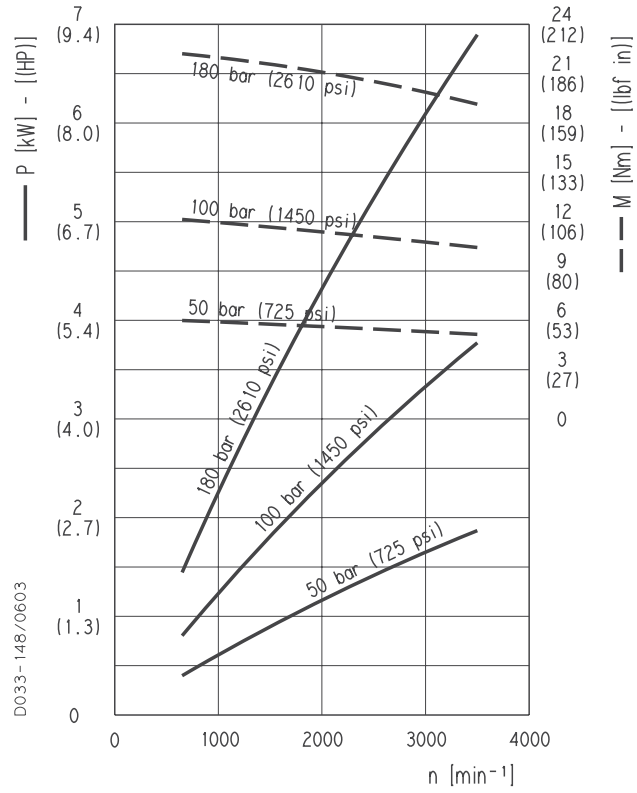

PLM 10•10

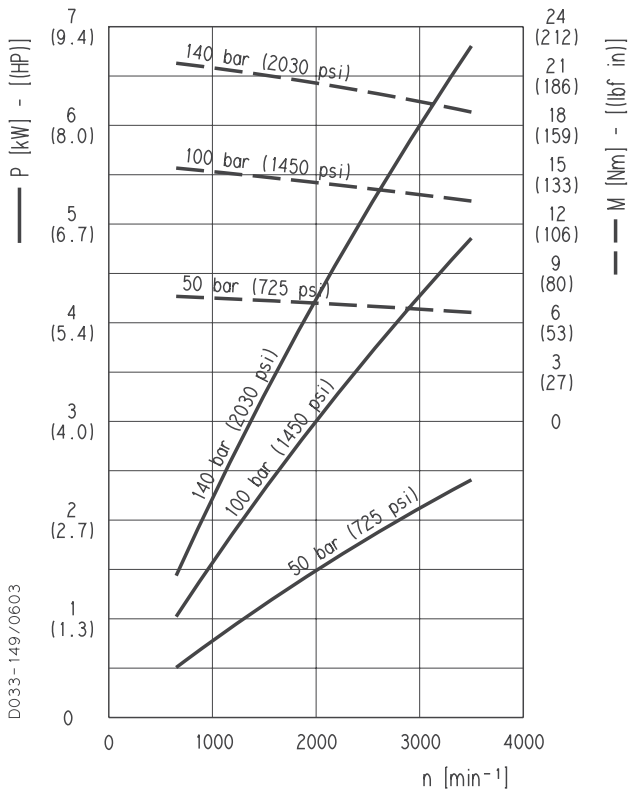

01/10.2003

PLM 20

POLARIS 20 GEAR MOTORS PERFORMANCE CURVES

PLM 20

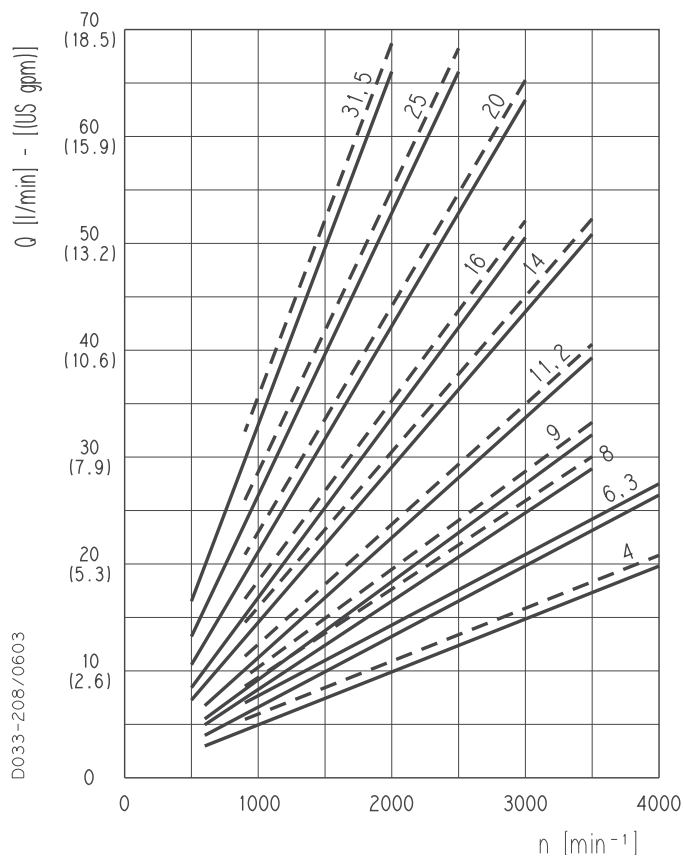

Each curve has been obtained at 50 °C (122 °F), using oil with viscosity 46 cSt (210 SSU) at 40 °C (104 °F) and at these pressures.

| | | |
|--------------------|-------|--------------------|
| PLM 20•4 | — | 20 bar (290 psi) |
| | - - - | 250 bar (3625 psi) |
| PLM 20•6,3 | — | 20 bar (290 psi) |
| | - - - | 250 bar (3625 psi) |
| PLM 20•8 | — | 20 bar (290 psi) |
| | - - - | 250 bar (3625 psi) |
| PLM 20•9 | — | 20 bar (290 psi) |
| | - - - | 250 bar (3625 psi) |
| PLM 20•11,2 | — | 20 bar (290 psi) |
| | - - - | 250 bar (3625 psi) |
| PLM 20•14 | — | 20 bar (290 psi) |
| | - - - | 250 bar (3625 psi) |
| PLM 20•16 | — | 20 bar (290 psi) |
| | - - - | 250 bar (3625 psi) |
| PLM 20•20 | — | 20 bar (290 psi) |
| | - - - | 200 bar (2900 psi) |
| PLM 20•25 | — | 20 bar (290 psi) |
| | - - - | 170 bar (2465 psi) |
| PLM 20•31,5 | — | 20 bar (290 psi) |
| | - - - | 130 bar (1885 psi) |
| PLM 20•7,2 | — | 20 bar (290 psi) |
| | - - - | 250 bar (3625 psi) |
| PLM 20•10,5 | — | 20 bar (290 psi) |
| | - - - | 250 bar (3625 psi) |
| PLM 20•19 | — | 20 bar (290 psi) |
| | - - - | 200 bar (2900 psi) |
| PLM 20•24,5 | — | 20 bar (290 psi) |
| | - - - | 270 bar (2465 psi) |
| PLM 20•27,8 | — | 20 bar (290 psi) |
| | - - - | 130 bar (1885 psi) |

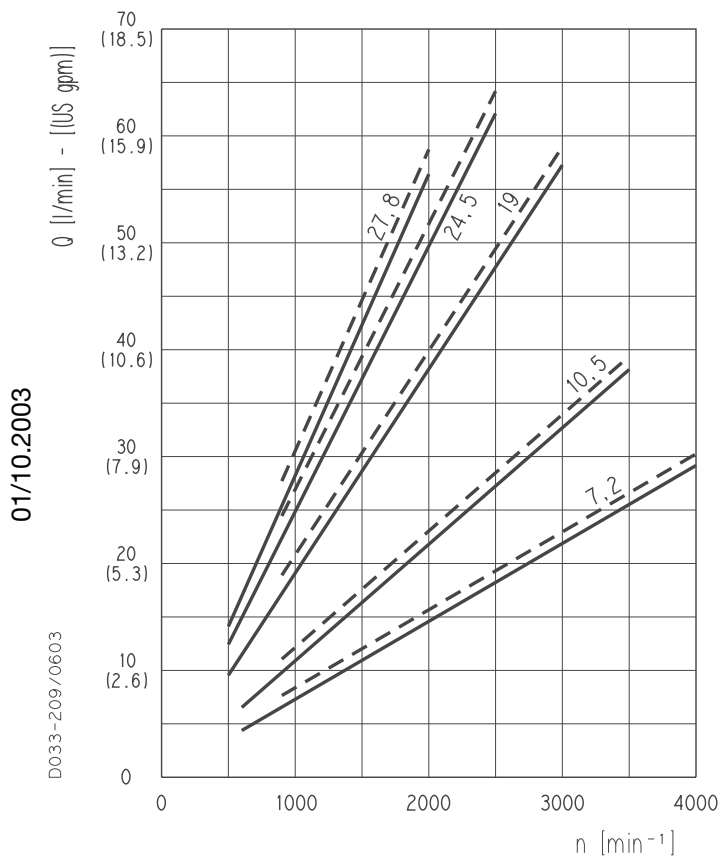

01/10.2003

PLM 20

POLARIS 20 GEAR MOTORS PERFORMANCE CURVES

PLM 20•4

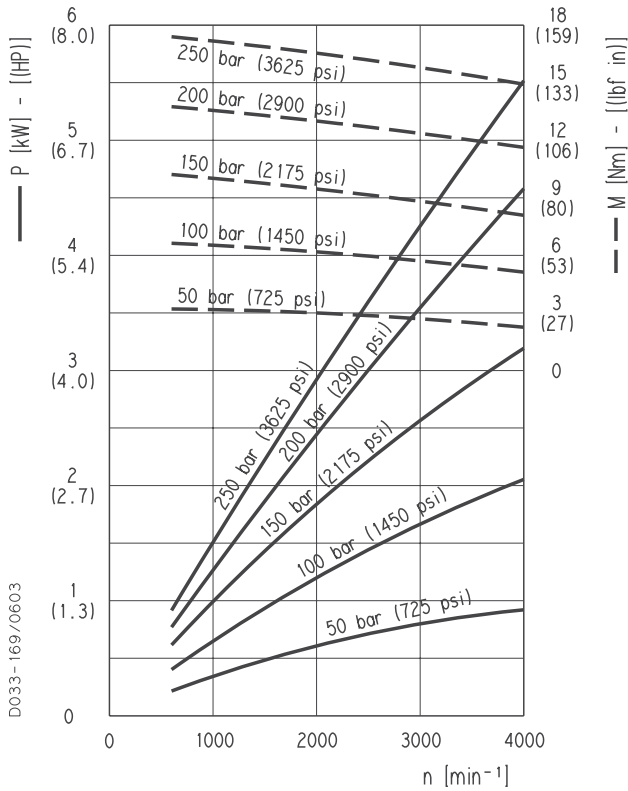

PLM 20•6,3

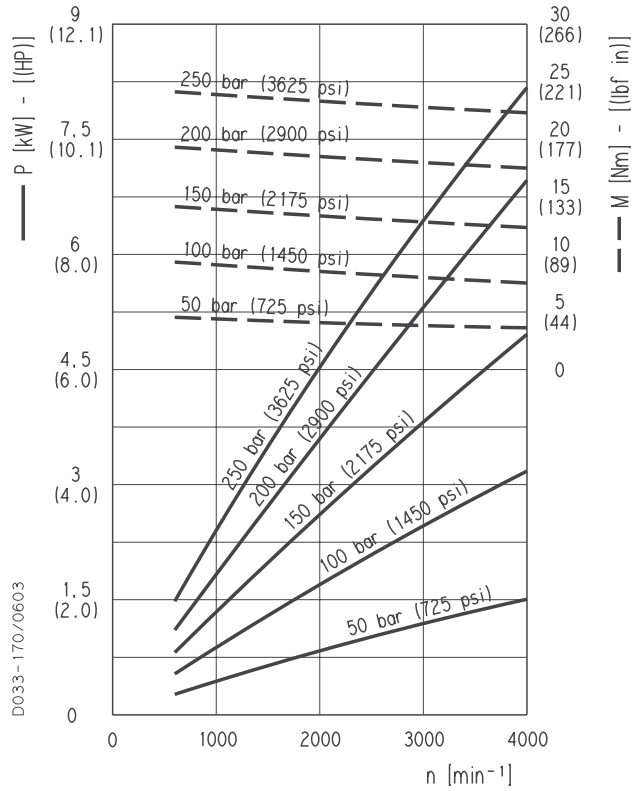

PLM 20•7,2

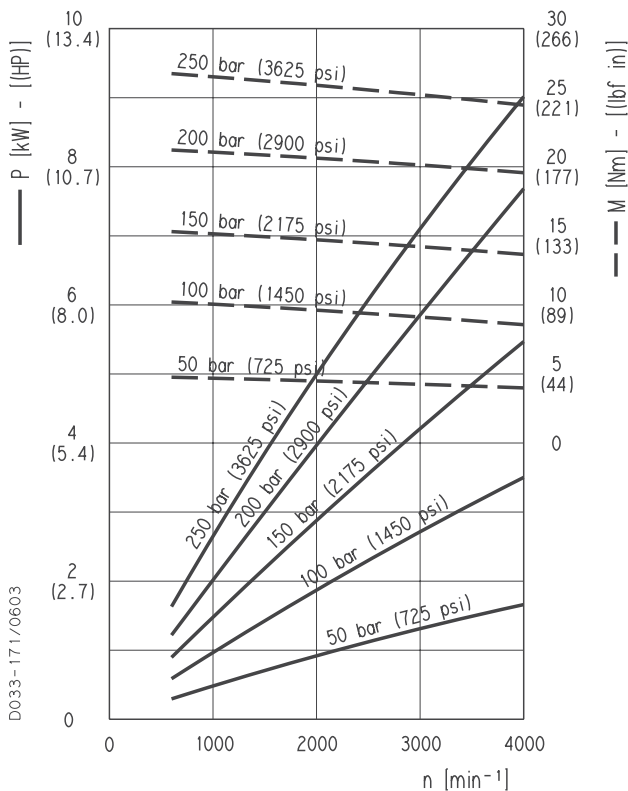

PLM 20•8

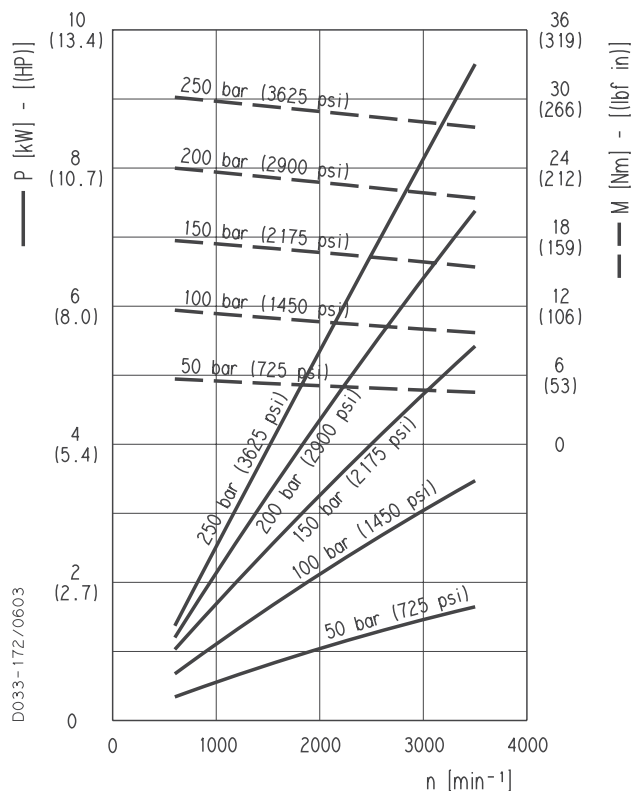

01/10.2003

PLM 20

POLARIS 20 GEAR MOTORS PERFORMANCE CURVES

PLM 20•9

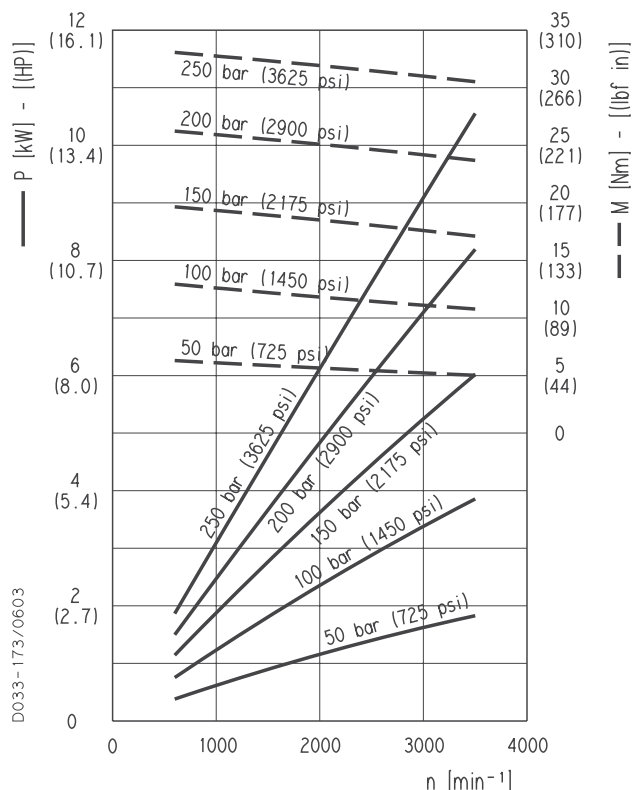

PLM 20•10,5

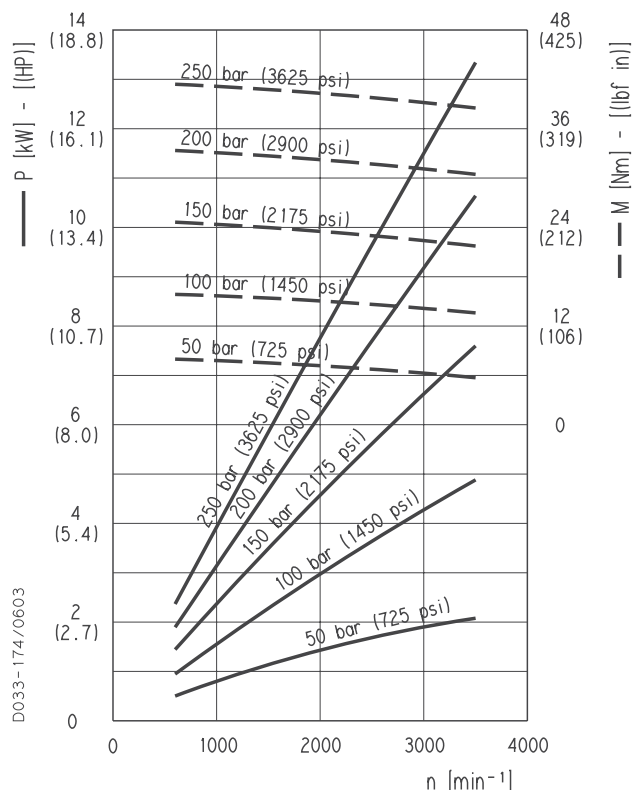

PLM 20•11,2

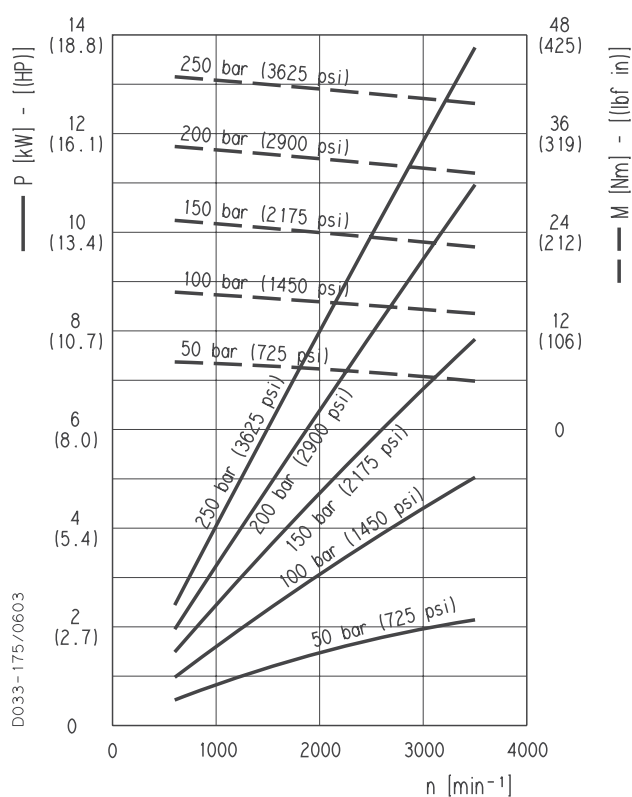

PLM 20•14

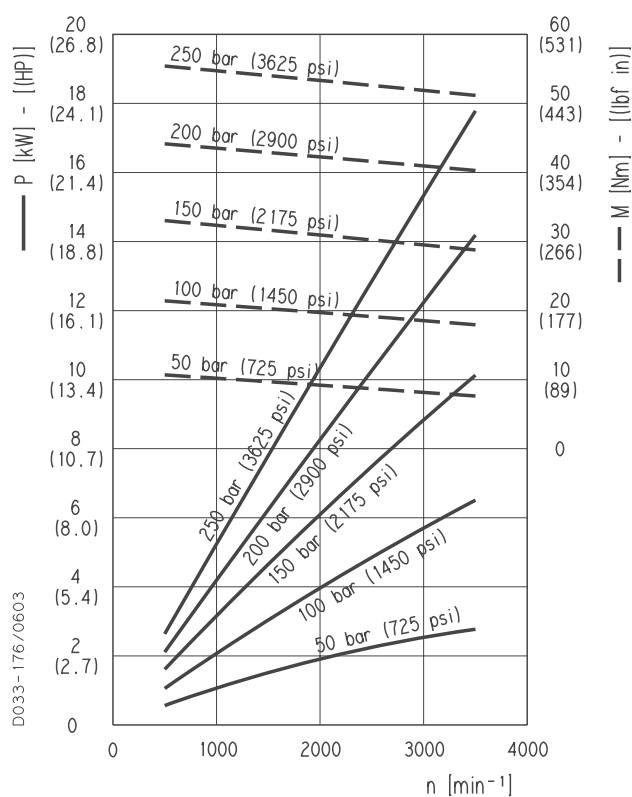

01/10.2003

PLM 20

POLARIS 20 GEAR MOTORS PERFORMANCE CURVES

PLM 20•16

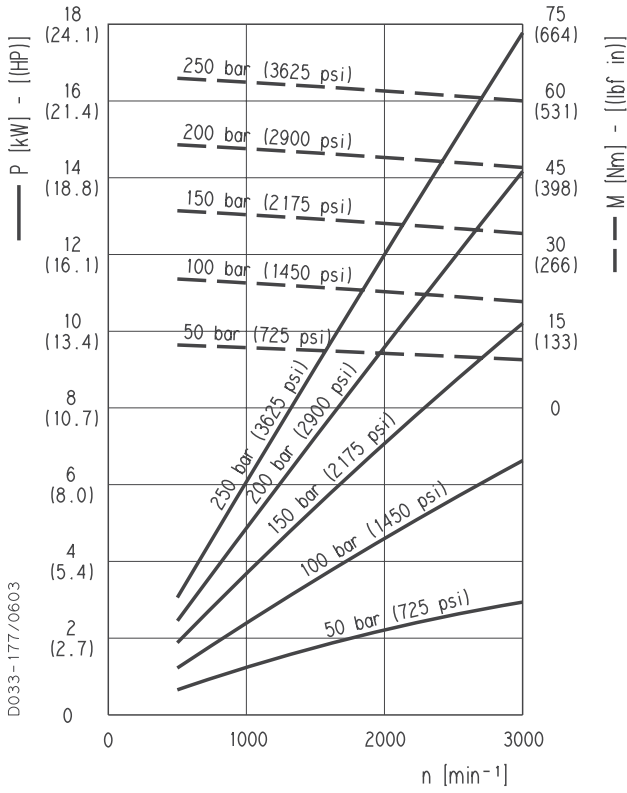

PLM 20•19

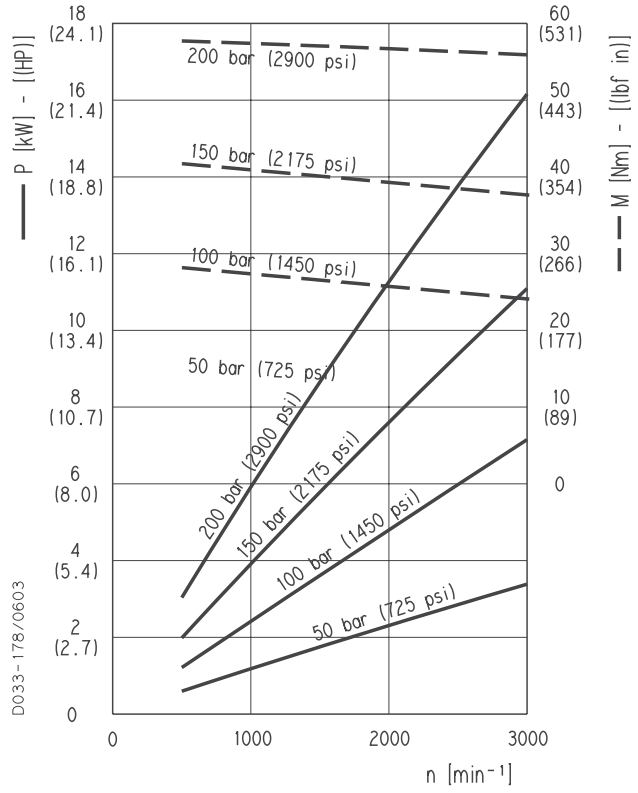

PLM 20•20

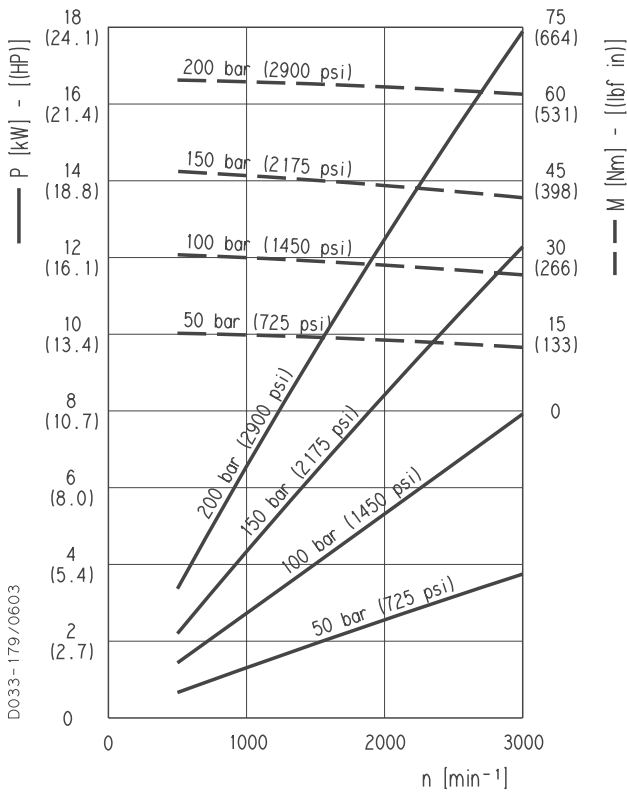

PLM 20•24,5

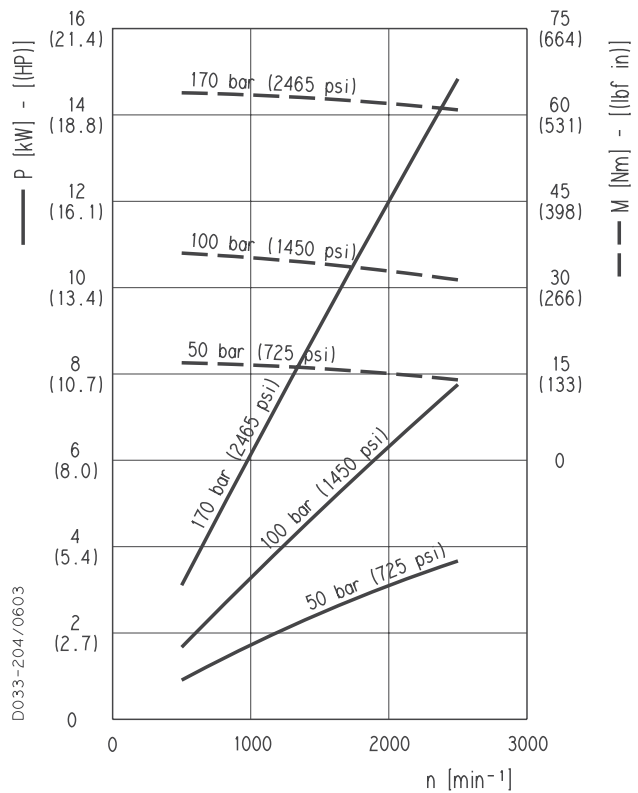

01/10.2003

PLM 20

POLARIS 20 GEAR MOTORS PERFORMANCE CURVES

PLM 20•25

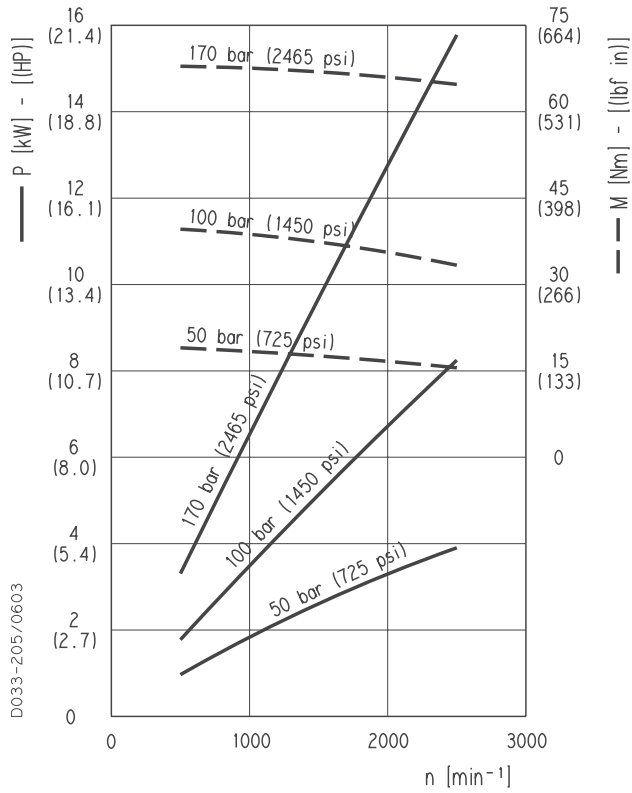

PLM 20•27,8

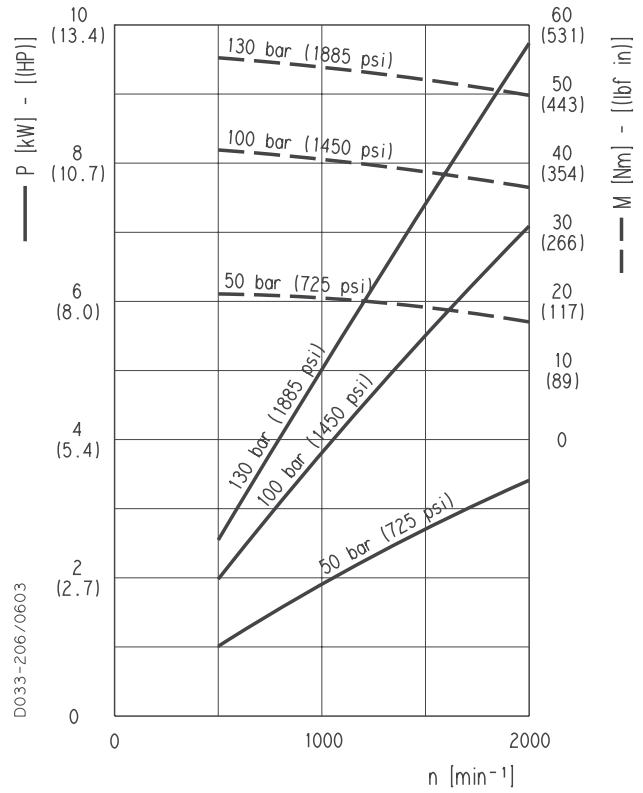

PLM 20•31,5

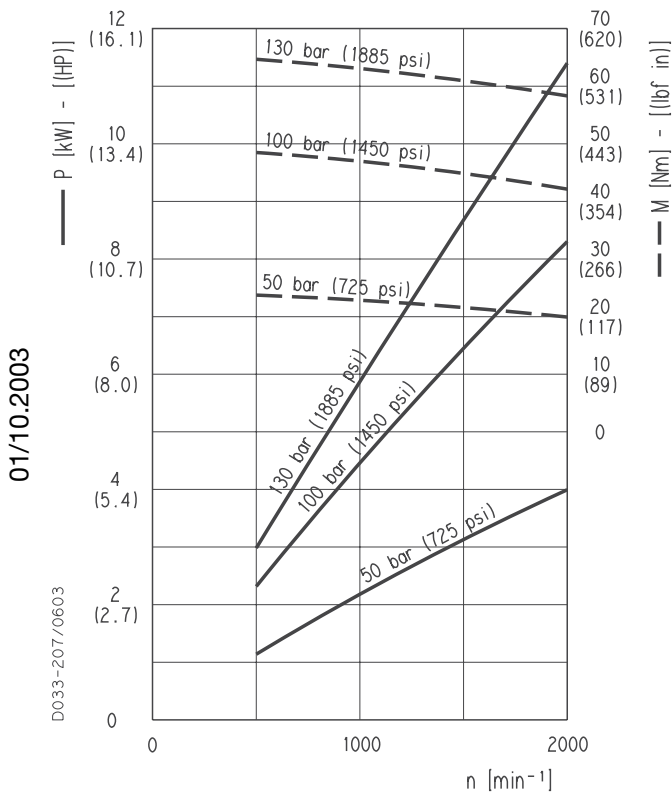

PLM 30

POLARIS 30 GEAR MOTORS PERFORMANCE CURVES

Each curve has been obtained at 50 °C (122 °F), using oil with viscosity 46 cSt (210 SSU) at 40 °C (104 °F) and at these pressures.

PLM 30

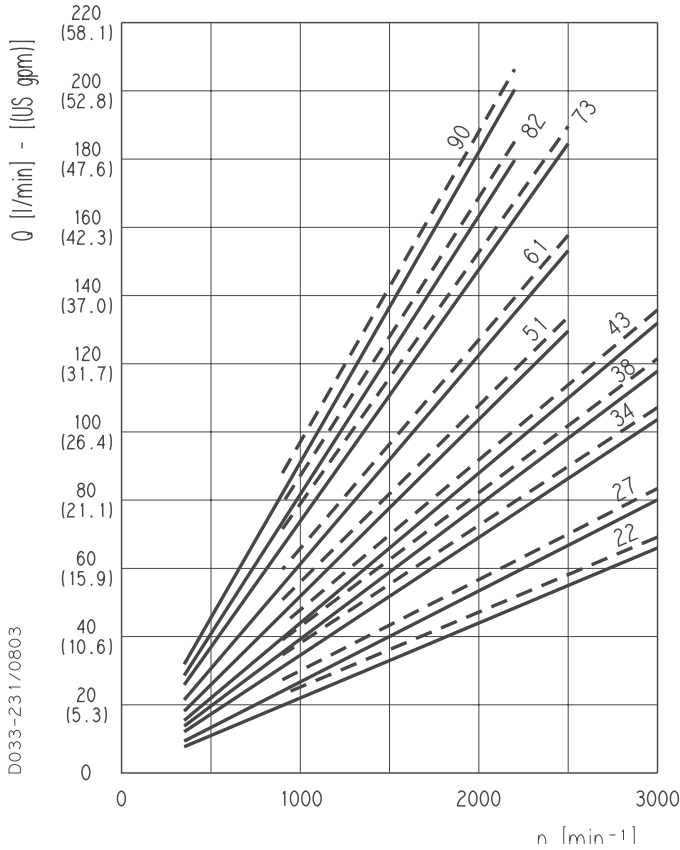

| | | |
|------------------|-------|--------------------|
| PLM 30•22 | — | 20 bar (290 psi) |
| | - - - | 250 bar (3625 psi) |
| PLM 30•27 | — | 20 bar (290 psi) |
| | - - - | 250 bar (3625 psi) |
| PLM 30•34 | — | 20 bar (290 psi) |
| | - - - | 240 bar (3480 psi) |
| PLM 30•38 | — | 20 bar (290 psi) |
| | - - - | 240 bar (3480 psi) |
| PLM 30•43 | — | 20 bar (290 psi) |
| | - - - | 230 bar (3335 psi) |
| PLM 30•51 | — | 20 bar (290 psi) |
| | - - - | 210 bar (3045 psi) |
| PLM 30•61 | — | 20 bar (290 psi) |
| | - - - | 190 bar (2775 psi) |
| PLM 30•73 | — | 20 bar (290 psi) |
| | - - - | 170 bar (2465 psi) |
| PLM 30•82 | — | 20 bar (290 psi) |
| | - - - | 160 bar (2320 psi) |
| PLM 30•90 | — | 20 bar (290 psi) |
| | - - - | 150 bar (2175 psi) |

PLM 30•22

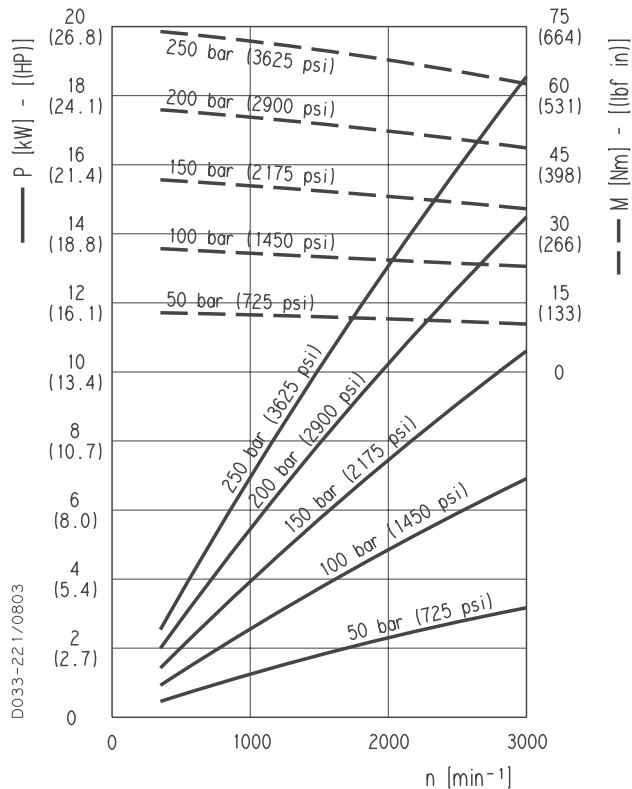

PLM 30•27

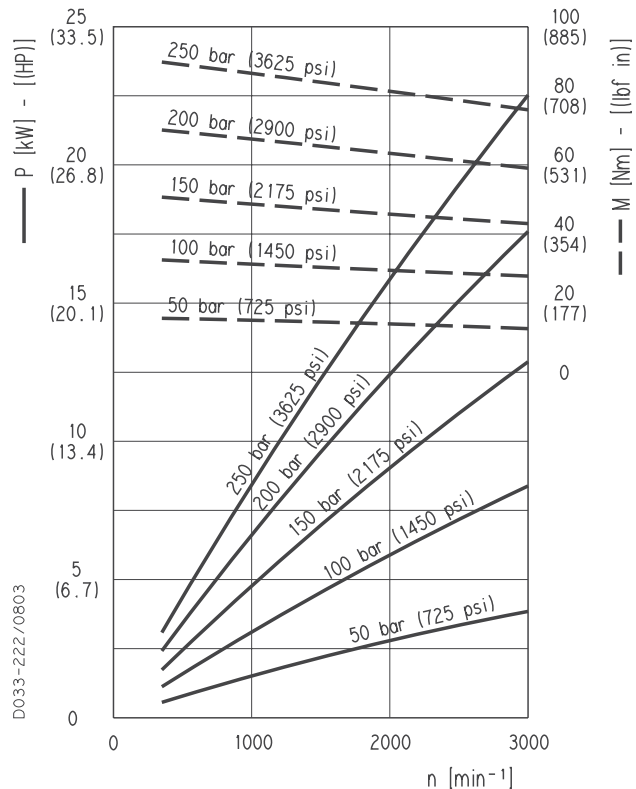

01/10.2003

PLM 30

POLARIS 30 GEAR MOTORS PERFORMANCE CURVES

PLM 30•34

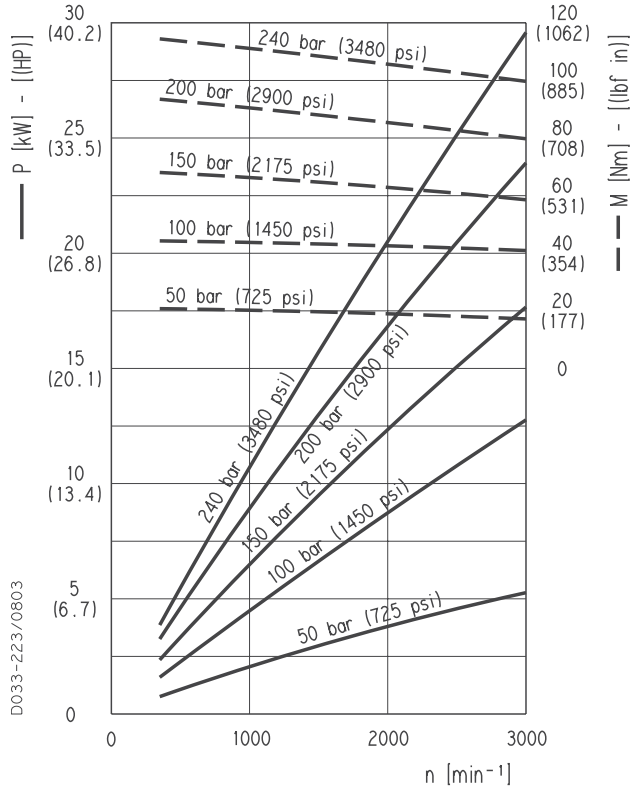

PLM 30•38

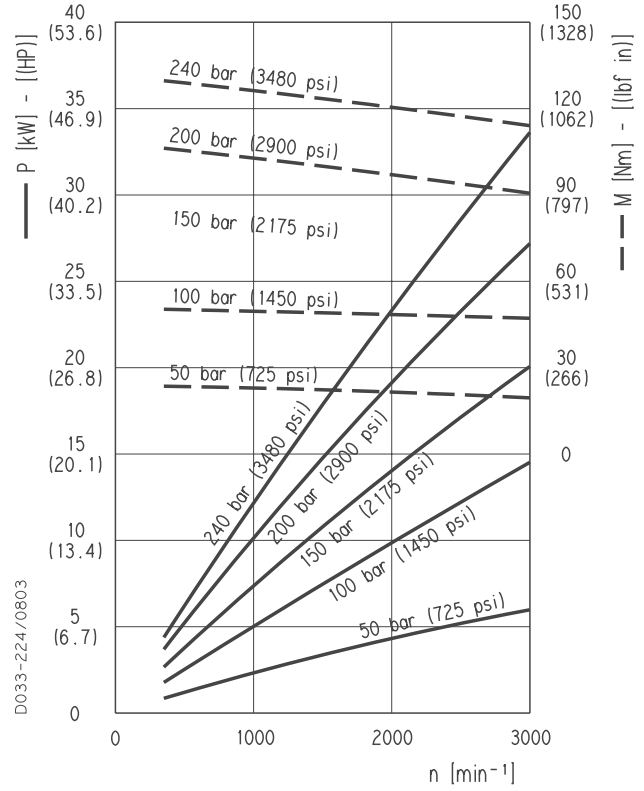

PLM 20•43

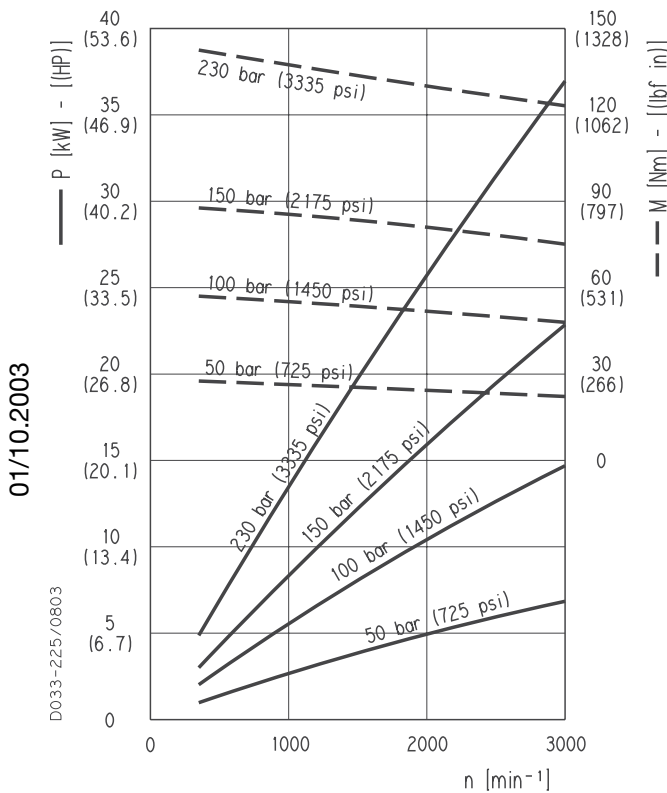

PLM 20•51

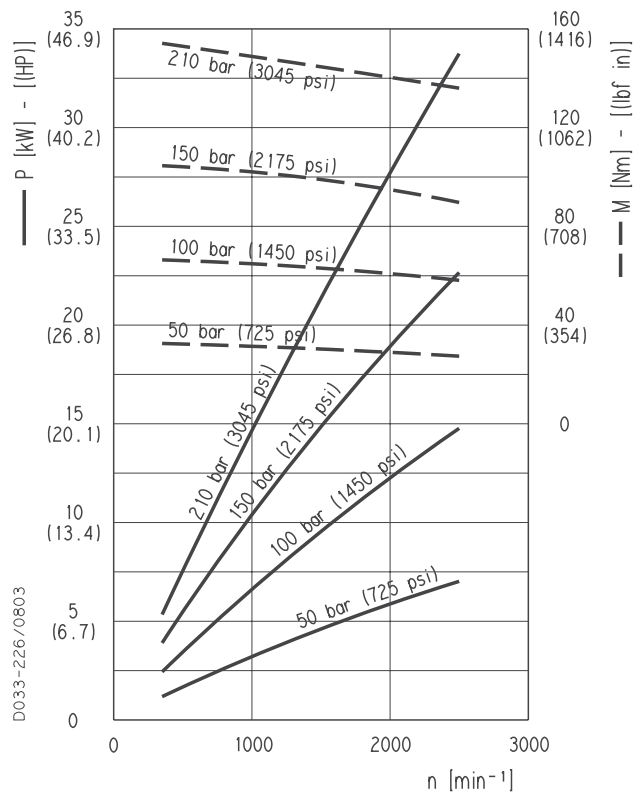

01/10.2003

PLM 30

POLARIS 30 GEAR MOTORS PERFORMANCE CURVES

PLM 30•61

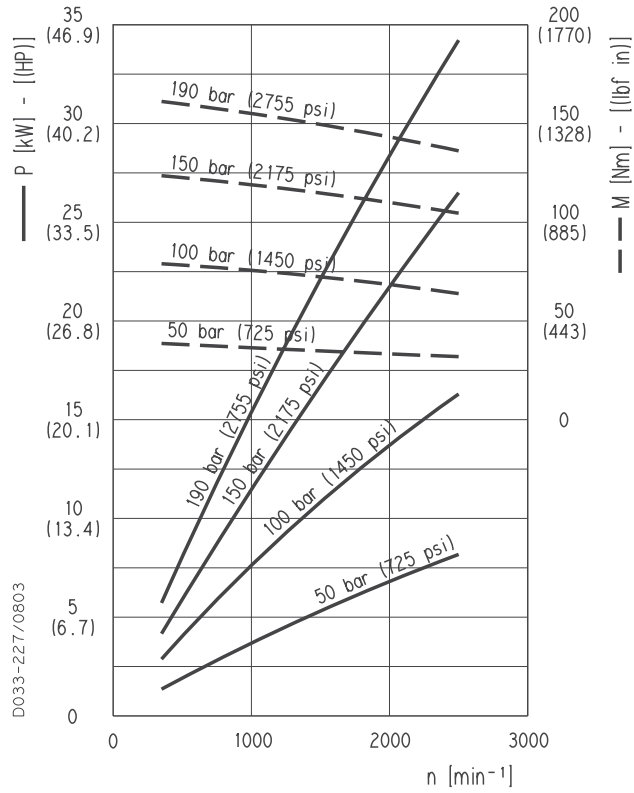

PLM 30•73

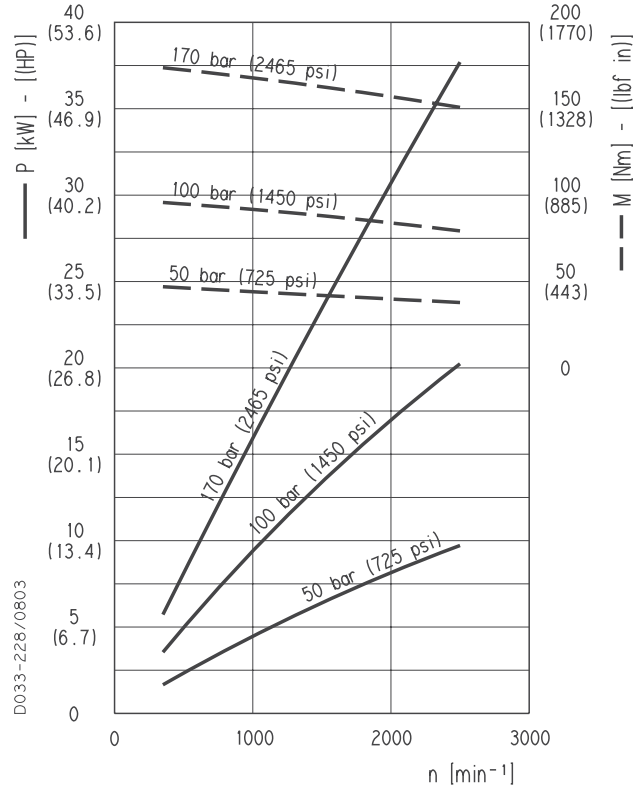

PLM 30•82

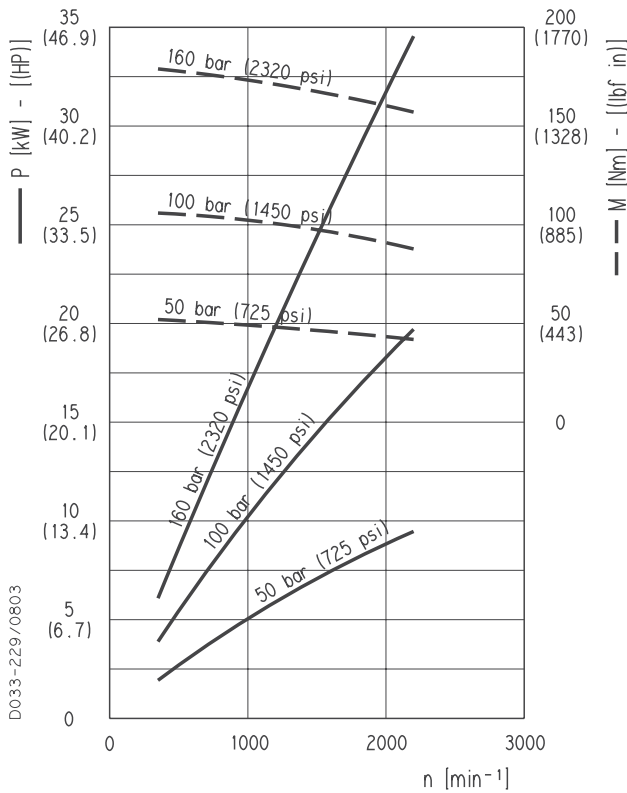

PLM 30•90

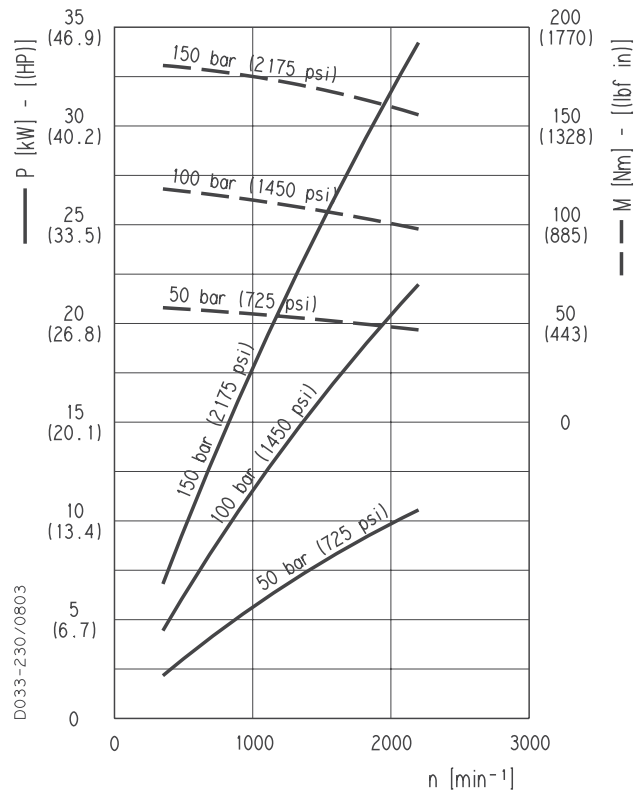

01/10.2003

NOTES

04/10.2020

POLARIS 10

SINGLE UNITS DIMENSIONS - SIDE PORTS

L

Drive shafts: page 52
Mounting flange: for X dimension see page 58 ÷ 60

Ports availability: Gas, SAE, German. See page 70

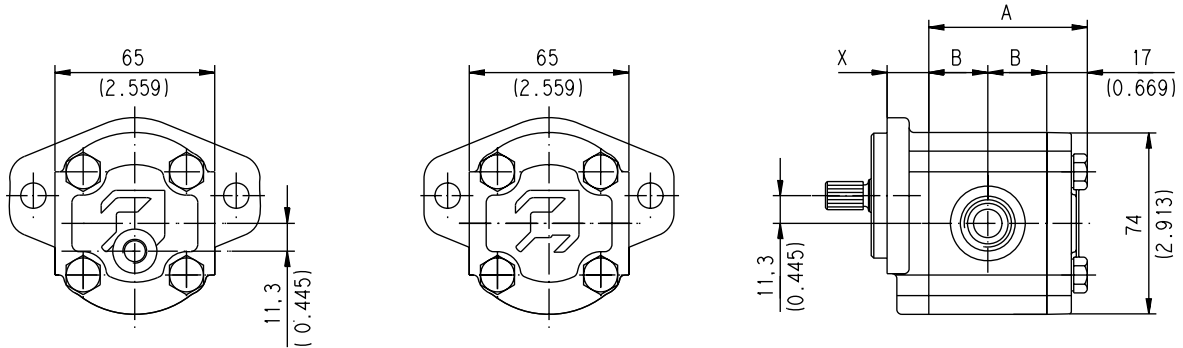

Reversible R

Single rotation S - D

D033-180/0903

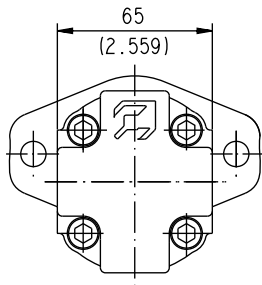

Reversible B

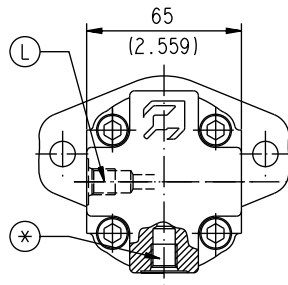

Reversible L

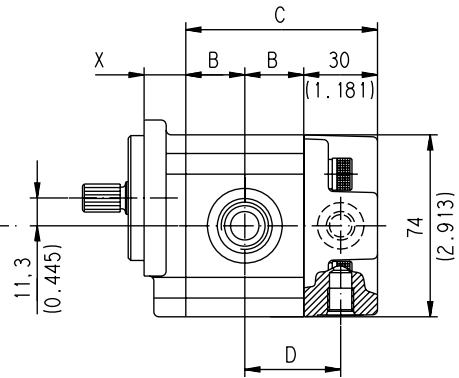

For single rotation S - D and reversible rotation R the rear cover is available in cast iron and aluminium.
For reversible rotation B and L the rear cover is in aluminium only.

Reversible L drain port position:
L = Side
* = Bottom

| Pump type Motor type | A | B | C | D |
|-------------------------|---------------|----------------|---------------|----------------|
| | mm (in) | mm (in) | mm (in) | mm (in) |
| PL 10•1 | 52,2 (2.0551) | 17,6 (0.6929) | 65,2 (2.5669) | 32,6 (1.2835) |
| PL 10•1,5 | 53,8 (2.1181) | 18,4 (0.7244) | 66,8 (2.6299) | 33,4 (1.3150) |
| PL 10•2 | 55,4 (2.1811) | 19,2 (0.7559) | 68,4 (2.6929) | 34,2 (1.3465) |
| PL 10•2,5 | 57 (2.2441) | 20 (0.7874) | 70 (2.7559) | 35 (1.3780) |
| PL 10•3,15 | 59 (2.3228) | 21 (0.8268) | 72 (2.8346) | 36 (1.4173) |
| PL 10•4 | 61,8 (2.4331) | 22,4 (0.8819) | 74,8 (2.9449) | 37,4 (1.4724) |
| PL 10•5 | 65 (2.5591) | 24 (0.9449) | 78 (3.0709) | 39 (1.5354) |
| PL 10•5,8 | 67,6 (2.6614) | 25,3 (0.9961) | 80,6 (3.1732) | 40,3 (1.5866) |
| PL 10•6,3 | 69 (2.7165) | 26 (1.0236) | 82 (3.2283) | 41 (1.6142) |
| PL 10•8 | 74,5 (2.9331) | 28,75 (1.1319) | 87,5 (3.4449) | 43,75 (1.7224) |
| PL 10•10 | 81 (3.1890) | 32 (1.2598) | 94 (3.7008) | 47 (1.8504) |

04/10.2020

POLARIS 10

SINGLE UNITS DIMENSIONS - REAR PORTS

P

Drive shafts: page 52

Ports availability: Gas, SAE

Mounting flange: for X dimension see page 58 ÷ 60

See page 70

D033-181/0903

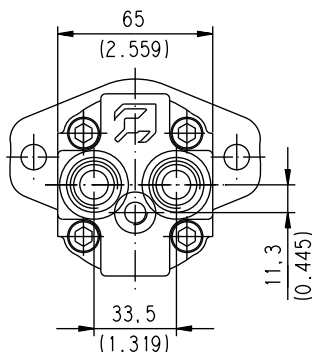

Reversible R

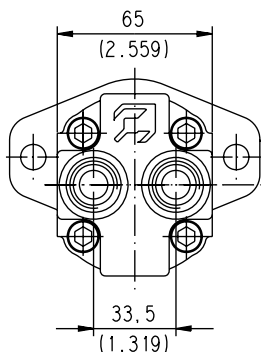

Single rotation S - D

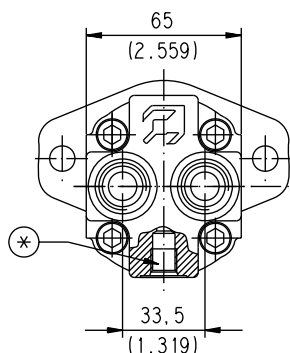

Reversible L

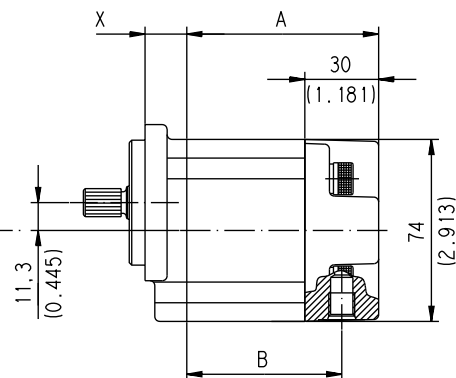
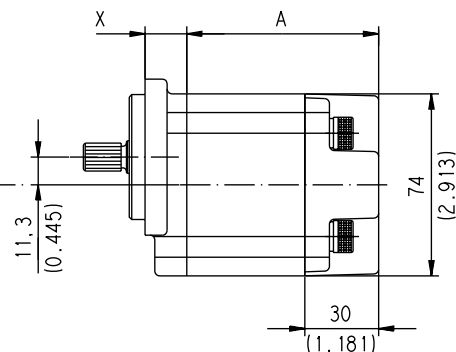

Rear cover in aluminium only.

Reversible L drain port position:
* = Bottom

04/10.2020

| Pump type | A | B |
|--------------------|---------------|---------------|
| Motor type | mm (in) | mm (in) |
| PL. 10•1 | 65,2 (2.5669) | 50,2 (1.9764) |
| PL. 10•1,5 | 66,8 (2.6299) | 51,8 (2.0394) |
| PL. 10•2 | 68,4 (2.6929) | 53,4 (2.0124) |
| PL. 10•2,5 | 70 (2.7559) | 55 (2.1654) |
| PL. 10•3,15 | 72 (2.8346) | 57 (2.2441) |
| PL. 10•4 | 74,8 (2.9449) | 59,8 (2.3543) |
| PL. 10•5 | 78 (3.0709) | 63 (2.4803) |
| PL. 10•5,8 | 80,6 (3.1732) | 65,6 (2.5827) |
| PL. 10•6,3 | 82 (3.2283) | 67 (2.6378) |
| PL. 10•8 | 87,5 (3.4449) | 72,5 (2.8543) |
| PL. 10•10 | 94 (3.7008) | 79 (3.1102) |

POLARIS 20

SINGLE UNITS DIMENSIONS - SIDE PORTS

L

Drive shafts: page 53 ÷ 55
Mounting flange: for X dimension see page 61 ÷ 66

Ports availability: European, Split, Gas, SAE German. See page 70

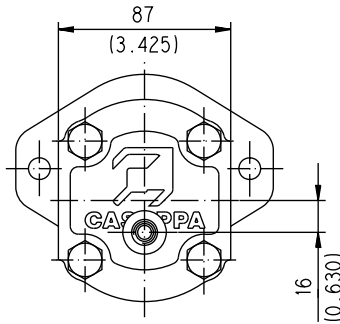

Reversible R

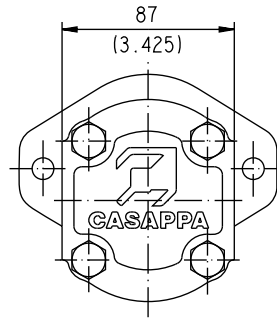

Single rotation S - D and Reversible B

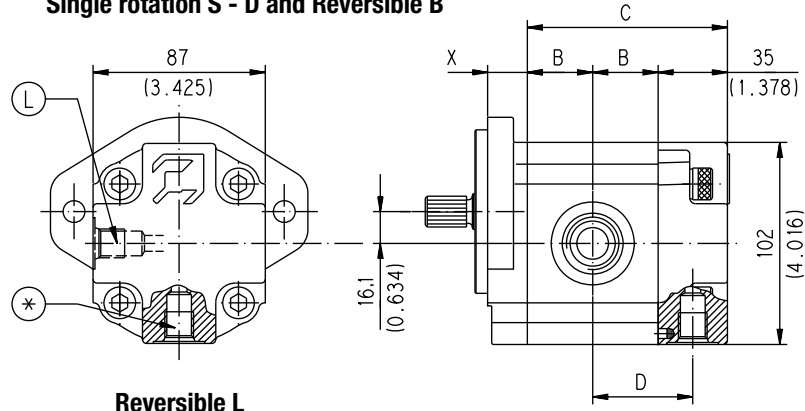
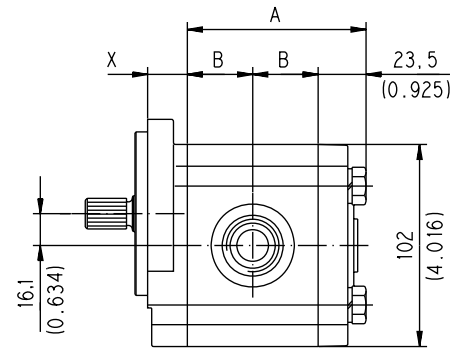

Reversible L

For single rotation S - D and reversible B and R the rear cover is available in cast iron and aluminium.
For reversible rotation L the rear cover is in aluminium only.

Reversible L drain port position:
L = Side
* = Bottom

| Pump type Motor type | A | B | C | D |
|-------------------------|----------------|----------------|----------------|----------------|
| | mm (in) | mm (in) | mm (in) | mm (in) |
| PL. 20•4 | 75 (2.9528) | 25,75 (1.0138) | 86,5 (3.4055) | 43,25 (1.7028) |
| PL. 20•6,3 | 77,5 (3.0512) | 27 (1.0630) | 89 (3.5039) | 44,5 (1.7520) |
| PL. 20•7,2 | 78,5 (3.0917) | 27,5 (1.083) | 90 (3.5445) | 45 (1.7722) |
| PL. 20•8 | 80 (3.1496) | 28,25 (1.1122) | 91,5 (3.6024) | 45,75 (1.8012) |
| PL. 20•9 | 81,3 (3.2008) | 28,9 (1.1378) | 92,8 (3.6535) | 46,4 (1.8268) |
| PL. 20•10,5 | 84 (3.3070) | 30,25 (1.1909) | 95,5 (3.7598) | 47,75 (1.8799) |
| PL. 20•11,2 | 84,5 (3.3268) | 30,5 (1.2008) | 96 (3.7795) | 48 (1.8898) |
| PL. 20•14 | 89,5 (3.5236) | 33 (1.2992) | 101 (3.9764) | 50,5 (1.9882) |
| PL. 20•16 | 93 (3.6614) | 34,75 (1.3681) | 104,5 (4.1142) | 52,25 (2.0571) |
| PL. 20•19 | 96,4 (3.7952) | 36,45 (1.4350) | 107,9 (4.2480) | 53,9 (2.12) |
| PL. 20•20 | 99,5 (3.9173) | 38 (1.4961) | 111 (4.3701) | 55,5 (2.1850) |
| PL. 20•24,5 | 105,1 (4.1378) | 40,8 (1.6063) | 116,6 (4.5905) | 58,3 (2.2953) |
| PL. 20•25 | 107,5 (4.2323) | 42 (1.6535) | 119 (4.6850) | 59,5 (2.3425) |
| PL. 20•27,8 | 110,2 (4.3386) | 43,35 (1.7067) | 121,7 (4.7913) | 60,85 (2.3957) |
| PL. 20•31,5 | 117,5 (4.6260) | 47 (1.8504) | 129 (5.0787) | 64,5 (2.5394) |

04/10.2020

POLARIS 20

SINGLE UNITS DIMENSIONS - REAR PORTS

P

Drive shafts: page 53 ÷ 55

Ports availability: Gas, SAE.

Mounting flange: for X dimension see
page 61 ÷ 66

See page 70

D033-183/0903

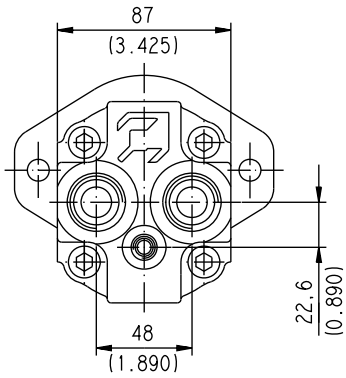

Reversible R

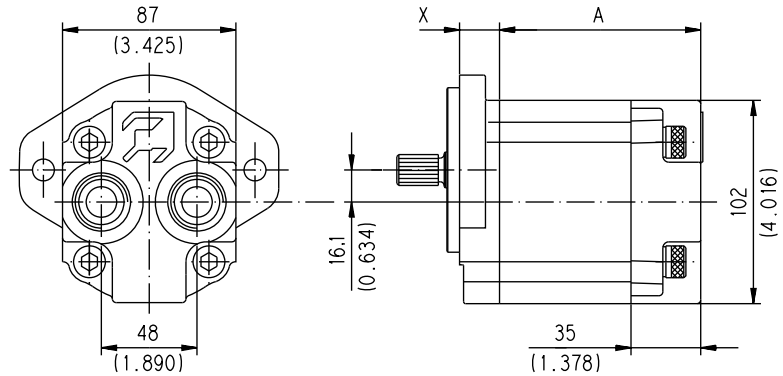

Single rotation S - D and Reversible B

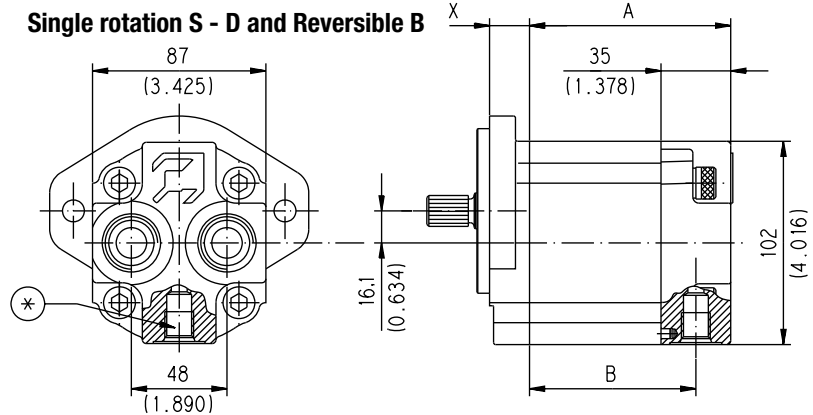

Reversible L

Rear cover in aluminium only.

Reversible L drain port position:
* = Bottom

04/10.2020

| Pump type Motor type | A | B |
|-------------------------|----------------|----------------|
| | mm (in) | mm (in) |
| PL. 20•4 | 86,5 (3.4055) | 69 (2.7165) |
| PL. 20•6,3 | 89 (3.5039) | 71,5 (2.8150) |
| PL. 20•7,2 | 90 (3.5445) | 72,5 (2.8555) |
| PL. 20•8 | 91,5 (3.6024) | 74 (2.9134) |
| PL. 20•9 | 92,8 (3.6535) | 75,3 (2.9646) |
| PL. 20•10,5 | 95,5 (3.7598) | 78 (3.0708) |
| PL. 20•11,2 | 96 (3.7795) | 78,5 (3.0906) |
| PL. 20•14 | 101 (3.9764) | 83,5 (3.2874) |
| PL. 20•16 | 104,5 (4.1142) | 87 (3.4252) |
| PL. 20•19 | 107,9 (4.2480) | 90,4 (3.5591) |
| PL. 20•20 | 111 (4.3701) | 93,5 (3.6811) |
| PL. 20•24,5 | 116,6 (4.5905) | 99,1 (3.9016) |
| PL. 20•25 | 119 (4.6850) | 101,5 (3.9961) |
| PL. 20•27,8 | 121,7 (4.7913) | 104,2 (4.1024) |
| PL. 20•31,5 | 129 (5.0787) | 111,5 (4.3898) |

POLARIS 30

SINGLE UNITS DIMENSIONS - SIDE PORTS

L

Drive shafts: page 56 ÷ 57

Ports availability: European, Split, Gas,
SAE German. See page 70

Mounting flange: for X dimension see
page 67 ÷ 69

D033-184/0903

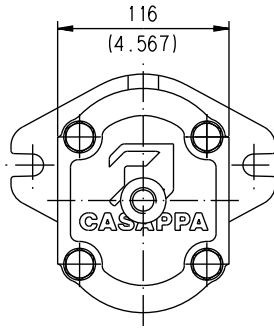

Reversible R

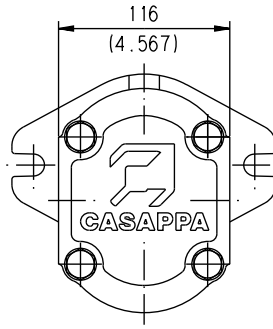

Single rotation S - D

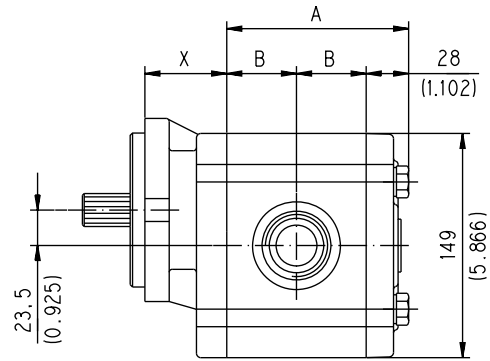

Rear cover in cast iron only.

| Pump type Motor type | A | B |
|-------------------------|--------------|---------------|
| | mm (in) | mm (in) |
| PL. 30•22 | 106 (4.1732) | 39 (1.5354) |
| PL. 30•27 | 109 (4.2913) | 40,5 (1.5945) |
| PL. 30•34 | 114 (4.4882) | 43 (1.6929) |
| PL. 30•38 | 117 (4.6063) | 44,5 (1.7520) |
| PL. 30•43 | 120 (4.7244) | 46 (1.8110) |
| PL. 30•51 | 125 (4.9212) | 48,5 (1.9094) |
| PL. 30•61 | 131 (5.1575) | 51,5 (2.0276) |
| PL. 30•73 | 139 (5.4724) | 55,5 (2.1850) |
| PL. 30•82 | 144 (5.6693) | 58 (2.2835) |
| PL. 30•90 | 150 (5.9055) | 61 (2.4016) |

04/10.2020

MULTIPLE PUMPS

POLARIS series pumps can be coupled together in combination. Where the input power requirements of each section varies, that with the greater requirement must be at the drive shaft end, and progressively smaller to the rear.

Replaces: 03/02.2012 Features and performances are the same as the corresponding single pumps, but pressures must be limited by the transmissible torque of the drive and connecting shafts. To have appropriate data, use the formula below.

The maximum rotational speed is that of the lowest rated speed of the single units incorporated.

Available with common inlet and separated stages. For more information please consult our pre-sales department.

| | | |
|---|---|-----------------------------|
| M | Nm (lbf in) | Torque |
| V | cm ³ /rev (in ³ /rev) | Displacement |
| Δp | bar (psi) | Pressure |
| $\eta_{hm} = \eta_{hm}(V, \Delta p, n)$ | | Hydro-mechanical efficiency |

$$M = \frac{M_{theor.}}{\eta_{hm}} \quad [Nm]$$

$$M_{theor.} = \frac{\Delta p \text{ (bar)} \cdot V \text{ (cm}^3\text{/rev)}}{62,83} \quad [Nm]$$

NOTE

The torque absorbed from the shaft of the first pump results from the sum of the torques of all the single stages. The achieved value must not exceed the maximum torque limit given for the shaft of the first pump.

05/04.2023

COMMON INLET - PORTS POSITION

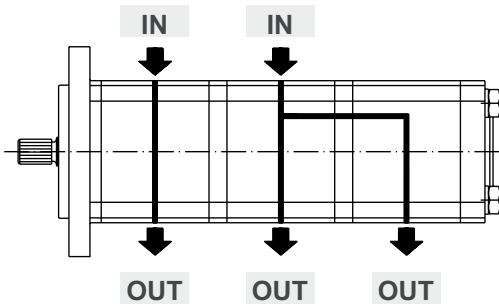
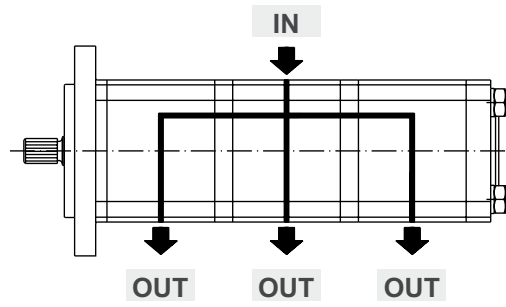
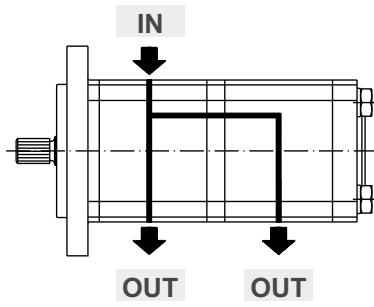

Reduced inlets provide overall systems savings by reducing the cost of redundant inlet hose and fittings.

Please contact us for other combinations.

MULTIPLE PUMPS COMBINATION

PL10

| | | |
|---------------|----------------------|-----------|
| Polaris 10/10 | STANDARD VERSION | V6 |
| Polaris 10/10 | COMMON INLET VERSION | V7 |

D033-112/0603

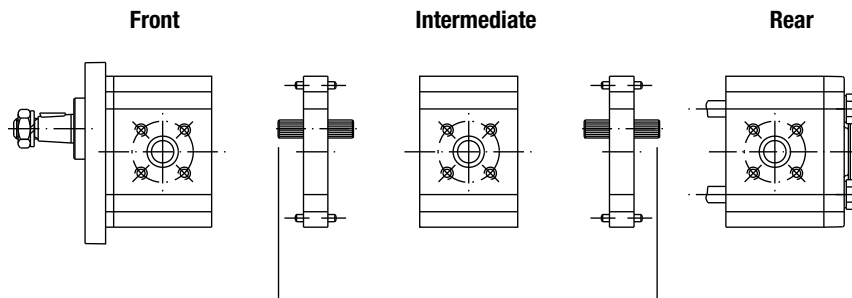

88 MAX 30 Nm (266 lbf in)

88 MAX 30 Nm (266 lbf in)

02/07.2006

MULTIPLE PUMPS COMBINATION

PLP 20

| | | |
|----------------------|-----------------------------|-----------|
| Polaris 20/20 | STANDARD VERSION | S6 |
| Polaris 20/20 | COMMON INLET VERSION | S7 |

D033-106/0603

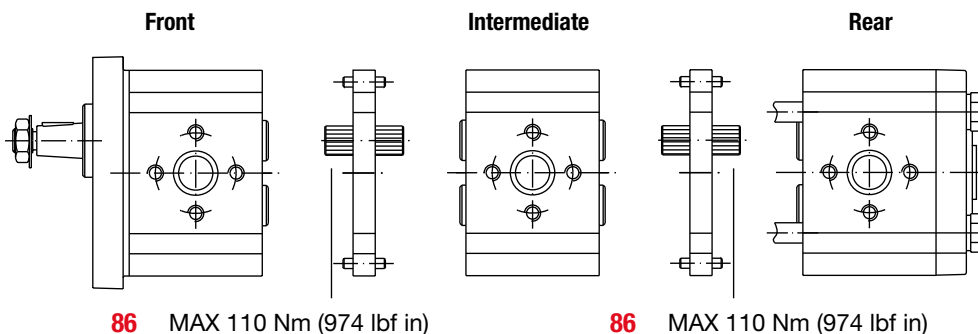

| | | |
|----------------------|---------------------------------|-----------|
| Polaris 20/20 | SEPARATED SRAGES VERSION | Z6 |
|----------------------|---------------------------------|-----------|

D033-110/0603

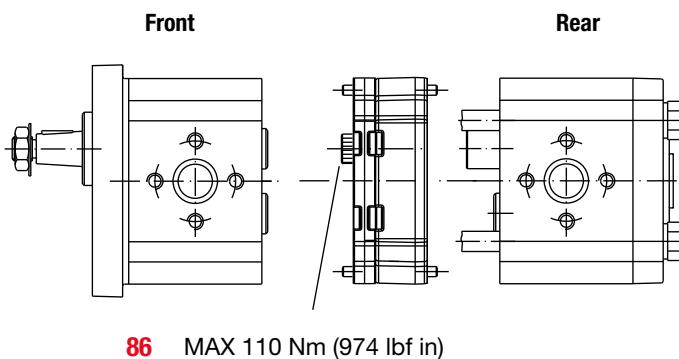

| | | |
|----------------------|-----------------------------|-----------|
| Polaris 20/10 | STANDARD VERSION | T6 |
| Polaris 20/10 | COMMON INLET VERSION | T7 |

D033-107/0603

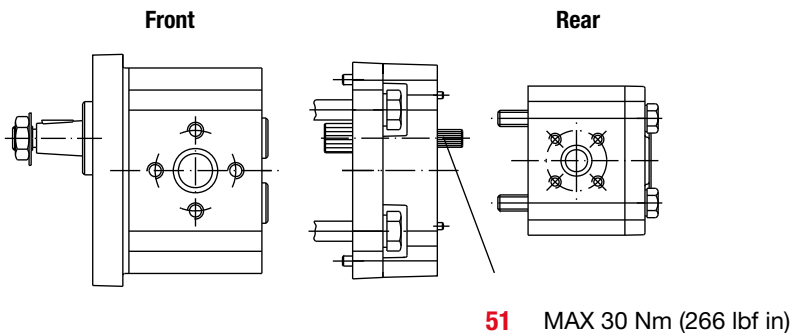

| | | |
|----------------------|---------------------------------|-----------|
| Polaris 20/10 | SEPARATED SRAGES VERSION | Z6 |
|----------------------|---------------------------------|-----------|

D033-111/0603

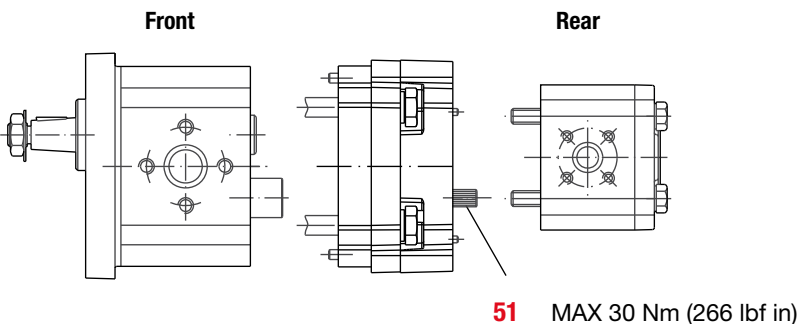

04/10.2020

MULTIPLE PUMPS COMBINATION

PLP 30

Polaris 30/30

STANDARD VERSION

M6

Front

Intermediate

Rear

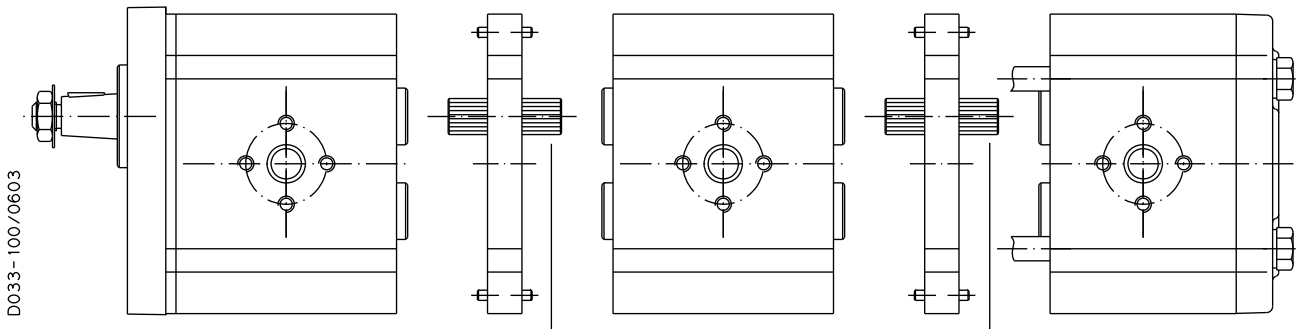

65 MAX 170 Nm (1505 lbf in)

65 MAX 170 Nm (1505 lbf in)

Polaris 30/20

STANDARD VERSION

N6

Polaris 30/20

COMMON INLET VERSION

N7

Front

Rear

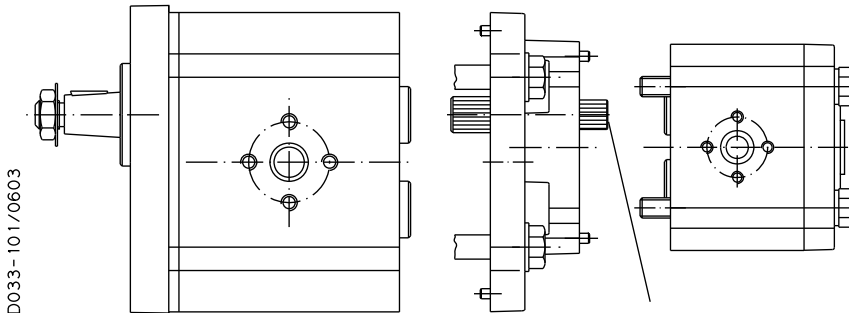

83 MAX 110 Nm (974 lbf in)

Polaris 30/20

SEPARATED SRAGES VERSION

Z6

Front

Rear

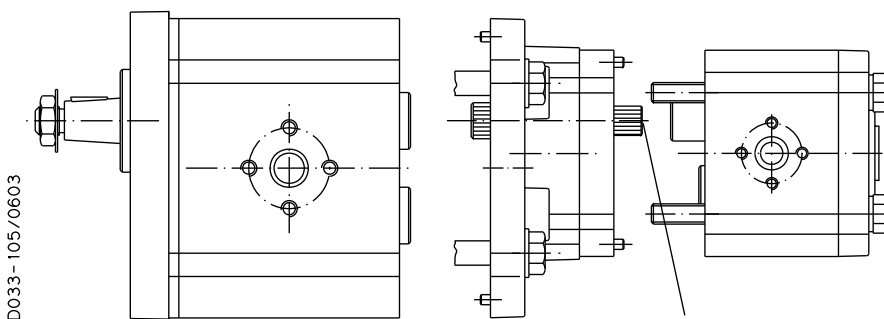

83 MAX 110 Nm (974 lbf in)

04/10.2020

MULTIPLE PUMPS COMBINATION

PLP 30

| | | |
|----------------------|-----------------------------|-----------|
| Polaris 30/20 | STANDARD VERSION | Q6 |
| Polaris 30/10 | COMMON INLET VERSION | Q7 |

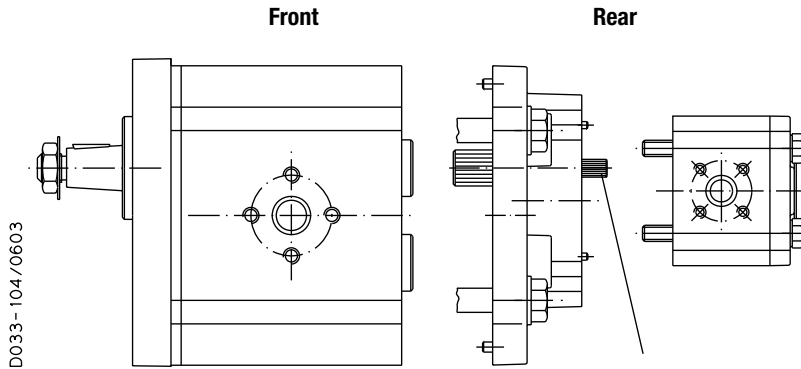

52 MAX 30 Nm (266 lbf in)

02/07.2006

POLARIS 10

MULTIPLE PUMPS DIMENSIONS

PLP10

Drive shafts: page 52
Mounting flange: for X dimension see page 58 ÷ 60

Ports availability: Gas, SAE,
German. See page 70

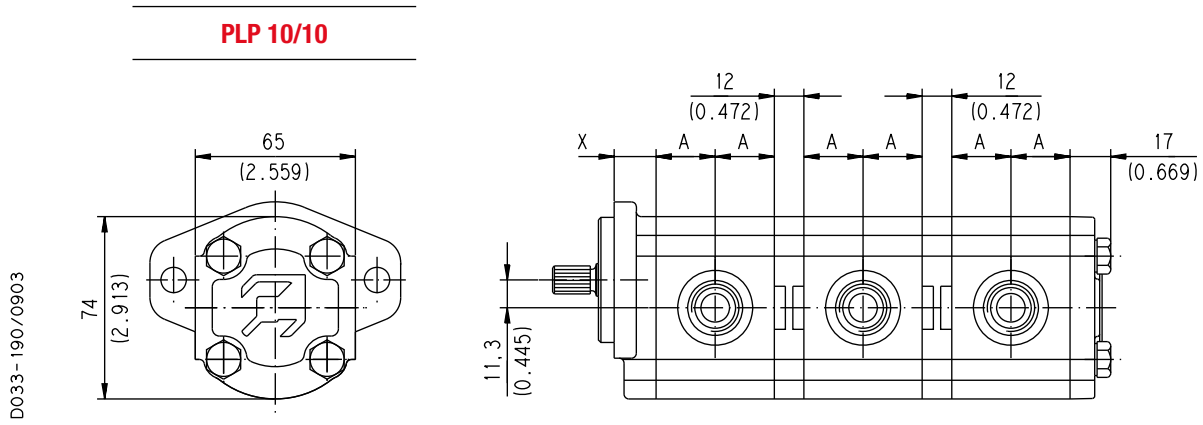

Rear cover available in cast iron and aluminium.

| Pump type | A |
|---------------------|---------------|
| | mm (in) |
| PLP. 10•1 | 17,6 (0.6929) |
| PLP. 10•1,5 | 18,4 (0.7244) |
| PLP. 10•2 | 19,2 (0.7559) |
| PLP. 10•2,5 | 20 (0.7874) |
| PLP. 10•3,15 | 21 (0.8268) |
| PLP. 10•4 | 22,4 (0.8819) |
| PLP. 10•5 | 24 (0.9449) |
| PLP. 10•5,8 | 25,3 (0.9961) |
| PLP. 10•6,3 | 26 (1.0236) |
| PLP. 10•8 | 28,7 (1.1319) |
| PLP. 10•10 | 32 (1.2598) |

04/10.2020

POLARIS 20

MULTIPLE PUMPS DIMENSIONS

PLP 20

Drive shafts: page 53 ÷ 55
Mounting flange: for X dimension see page 61 ÷ 65

Ports availability: European, Split, Gas, SAE German. See page 70

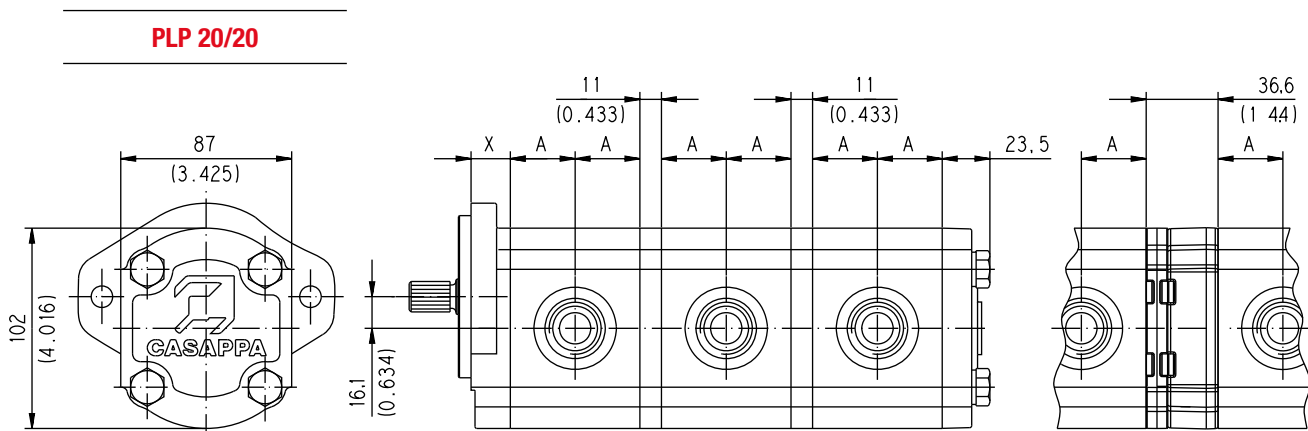

Separated stages

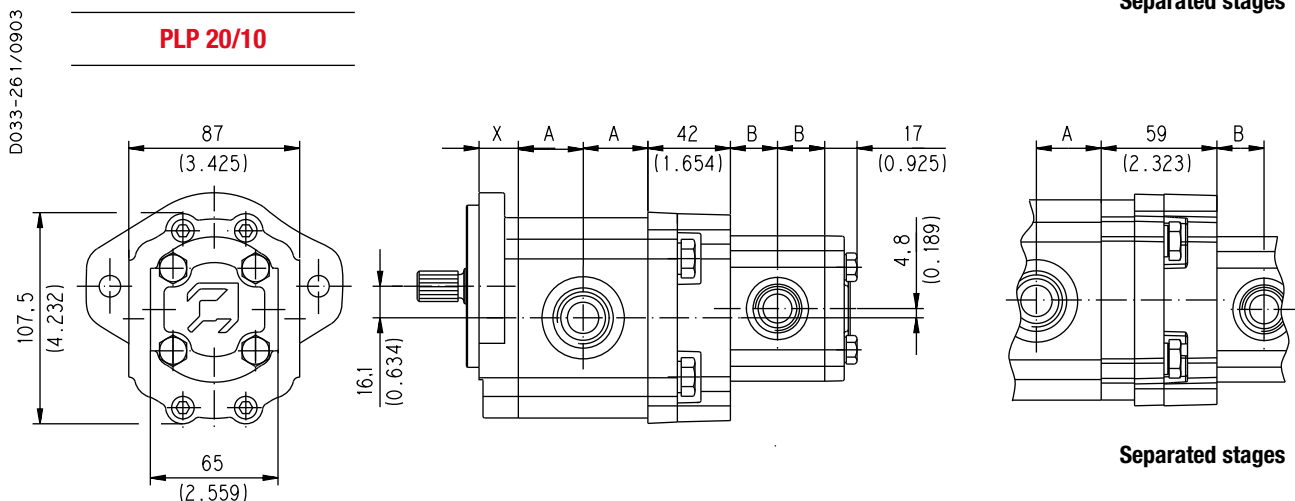

Separated stages

| Pump type | A mm (in) |
|--------------------|---------------------|
| PLP 20•4 | 25,75 (1.0138) |
| PLP 20•6,3 | 27 (1.0630) |
| PLP 20•7,2 | 27,5 (1.0827) |
| PLP 20•8 | 28,25 (1.1122) |
| PLP 20•9 | 28,9 (1.1378) |
| PLP 20•10,5 | 30,25 (1.1909) |
| PLP 20•11,2 | 30,5 (1.2008) |
| PLP 20•14 | 33 (1.2992) |
| PLP 20•16 | 34,75 (1.3681) |
| PLP 20•19 | 36,45 (1.4350) |
| PLP 20•20 | 38 (1.4961) |
| PLP 20•24,5 | 40,8 (1.6063) |
| PLP 20•25 | 42 (1.6535) |
| PLP 20•27,5 | 43,35 (1.7067) |
| PLP 20•31,5 | 47 (1.8504) |

Rear cover available in cast iron and aluminium.

| Pump type | B mm (in) |
|--------------------|---------------------|
| PLP 10•1 | 17,6 (0.6929) |
| PLP 10•1,5 | 18,4 (0.7244) |
| PLP 10•2 | 19,2 (0.7559) |
| PLP 10•2,5 | 20 (0.7874) |
| PLP 10•3,15 | 21 (0.8268) |
| PLP 10•4 | 22,4 (0.8819) |
| PLP 10•5 | 24 (0.9449) |
| PLP 10•5,8 | 25,3 (0.9961) |
| PLP 10•6,3 | 26 (1.0236) |
| PLP 10•8 | 28,75 (1.1319) |
| PLP 10•10 | 32 (1.2598) |

04/10.2020

POLARIS 30

MULTIPLE PUMPS DIMENSIONS

PLP30

Drive shafts: page 56 ÷ 57
Mounting flange: for X dimension see page 67 ÷ 69

Ports availability: European, Split, Gas, SAE German. See page 70

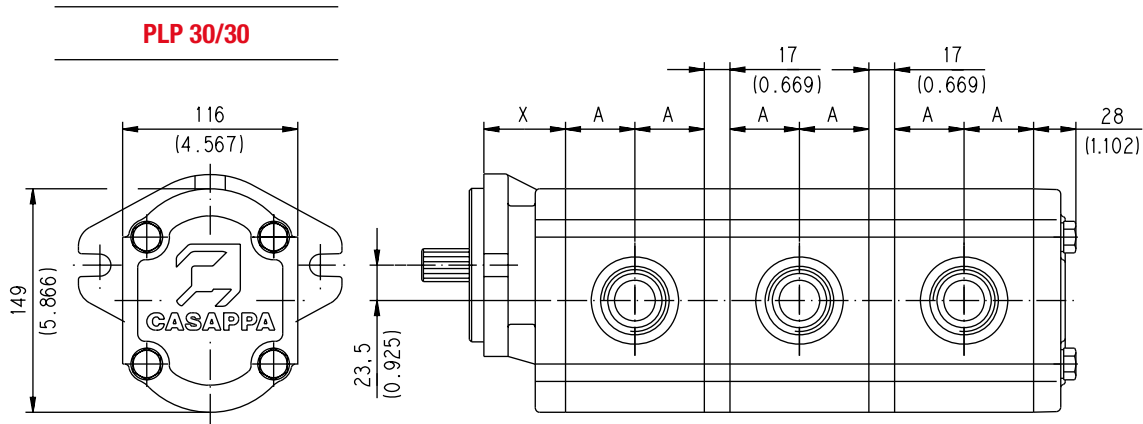

Rear cover in cast iron only.

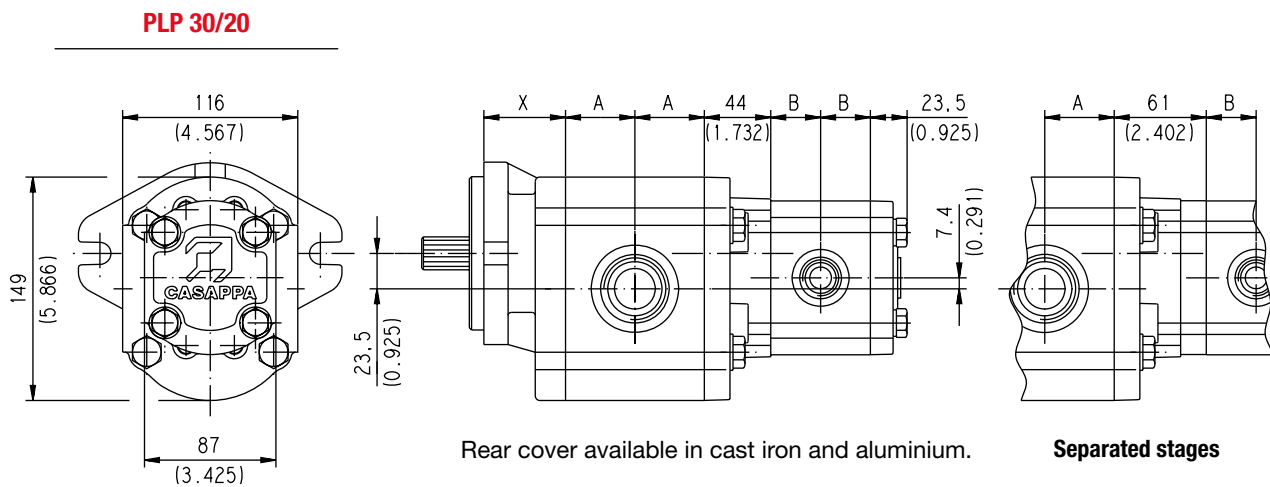

Rear cover available in cast iron and aluminium.

Separated stages

D033-260/0903

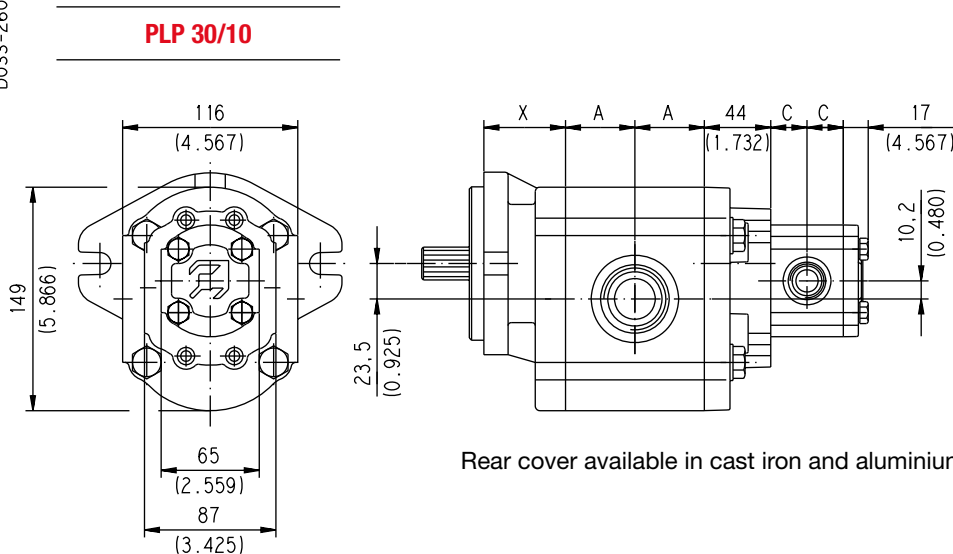

Rear cover available in cast iron and aluminium.

04/10.2020

POLARIS 30
MULTIPLE PUMPS DIMENSIONS
PLP30

| A | | B | | C | |
|------------------|---------------|--------------------|----------------|--------------------|----------------|
| Pump type | mm (inch) | Pump type | mm (inch) | Pump type | mm (inch) |
| PLP 30•22 | 39 (1.5354) | PLP 20•4 | 25,75 (1.0138) | PLP 10•1 | 17,6 (0.6929) |
| PLP 30•27 | 40,5 (1.5945) | PLP 20•6,3 | 27 (1.0630) | PLP 10•1,5 | 18,4 (0.7244) |
| PLP 30•34 | 43 (1.6929) | PLP 20•7,2 | 27,5 (1.0827) | PLP 10•2 | 19,2 (0.7559) |
| PLP 30•38 | 44,5 (1.7520) | PLP 20•8 | 28,25 (1.1122) | PLP 10•2,5 | 20 (0.7874) |
| PLP 30•43 | 46 (1.8110) | PLP 20•9 | 28,9 (1.1378) | PLP 10•3,15 | 21 (0.8268) |
| PLP 30•51 | 48,5 (1.9094) | PLP 20•10,5 | 30,25 (1.1909) | PLP 10•4 | 22,4 (0.8819) |
| PLP 30•61 | 51,5 (2.0276) | PLP 20•11,2 | 30,5 (1.2008) | PLP 10•5 | 24 (0.9449) |
| PLP 30•73 | 55,5 (2.1850) | PLP 20•14 | 33 (1.2992) | PLP 10•5,8 | 25,3 (0.9961) |
| PLP 30•82 | 58 (2.2835) | PLP 20•16 | 34,75 (1.3681) | PLP 10•6,3 | 26 (1.0236) |
| PLP 30•90 | 61 (2.4016) | PLP 20•19 | 36,45 (1.4350) | PLP 10•8 | 28,75 (1.1319) |
| | | PLP 20•20 | 38 (1.4961) | PLP 10•10 | 32 (1.2598) |
| | | PLP 20•24,5 | 40,8 (1.6063) | | |
| | | PLP 20•25 | 42 (1.6535) | | |
| | | PLP 20•27,5 | 43,35 (1.7067) | | |
| | | PLP 20•31,5 | 47 (1.8504) | | |

02/07.2006

OUTBOARD BEARING OPTIONS

For each version, the possible combination between drive shafts and mounting flanges are shown on pages 58 ÷ 69.
For the outboard bearing life expectancy, diagrams providing approximate selection data will be found on subsequent pages.
Please contact us for particular applications.

PLP 10 - 20 - 30

VERSION 0

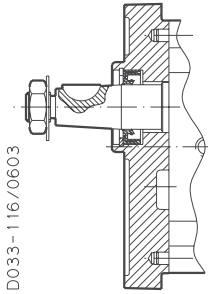

Version for applications without radial and axial load on the drive shaft.

PLP20 VERSION W8

Only available in 55 W8

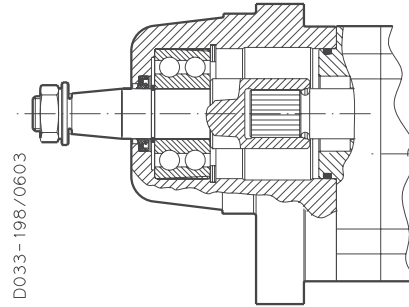

PLP20 VERSION 5

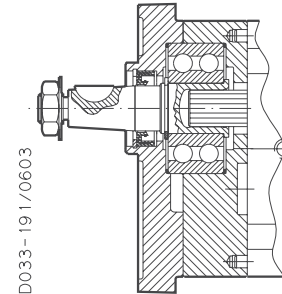

PLP20 VERSION 7

Only available in 82 E2

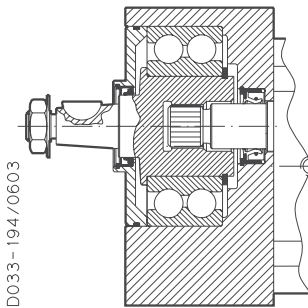

PLP20 VERSION 8

Only available in B1 E2

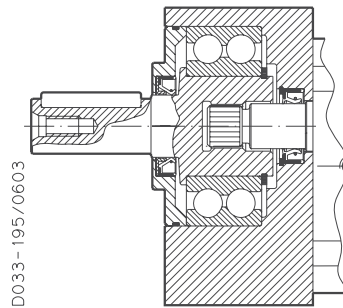

PLP20 VERSION 9

Only available in 55 B2

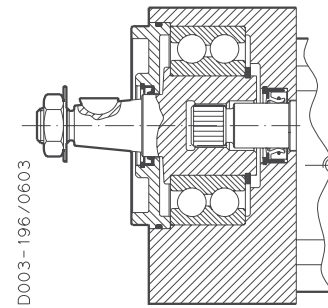

POLARIS 20

VERSION WITH OUTBOARD BEARING

W8

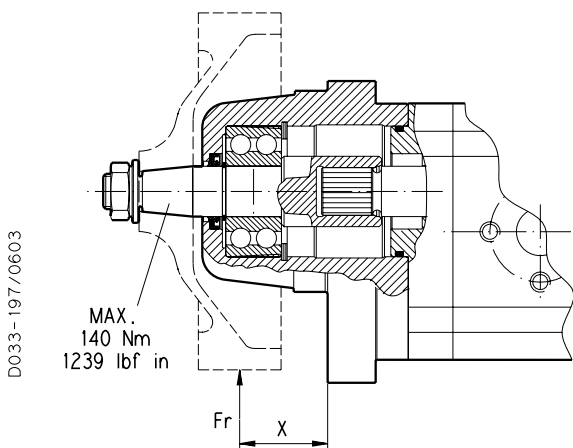

X = Distance of the radial load result from the mounting flange [mm (in)].

Each curve has been obtained at:

- Lubricant oil ISO VG 46
- Temperature 60 °C (140 °F)
- Without axial load
- Contamination level according ISO 281: $\beta_{12}(C) = 200$
- Reliability level of the calculation 90%

Example

| | |
|--------------------|------------------------|
| Fr Radial load | 1900 N (427.5 lbf) |
| X | 20 mm (0.79 in) |
| Speed | 2000 min ⁻¹ |
| Rated fatigue life | ≈ 3050 h |

Values shown in the diagrams are indicative only. Please contact us for more information.

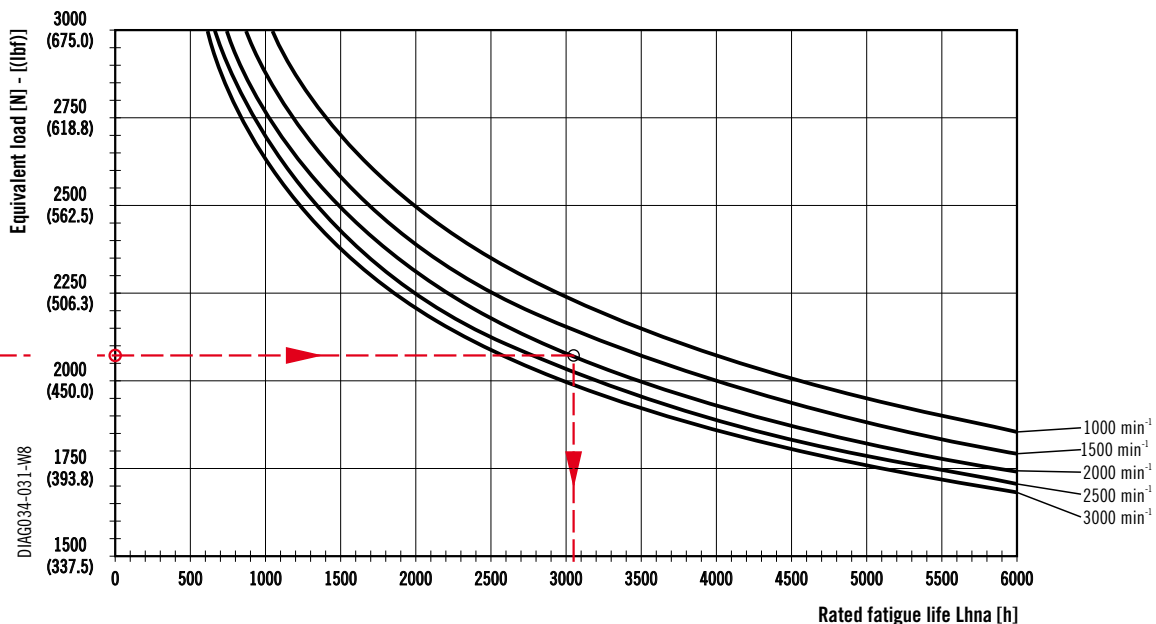
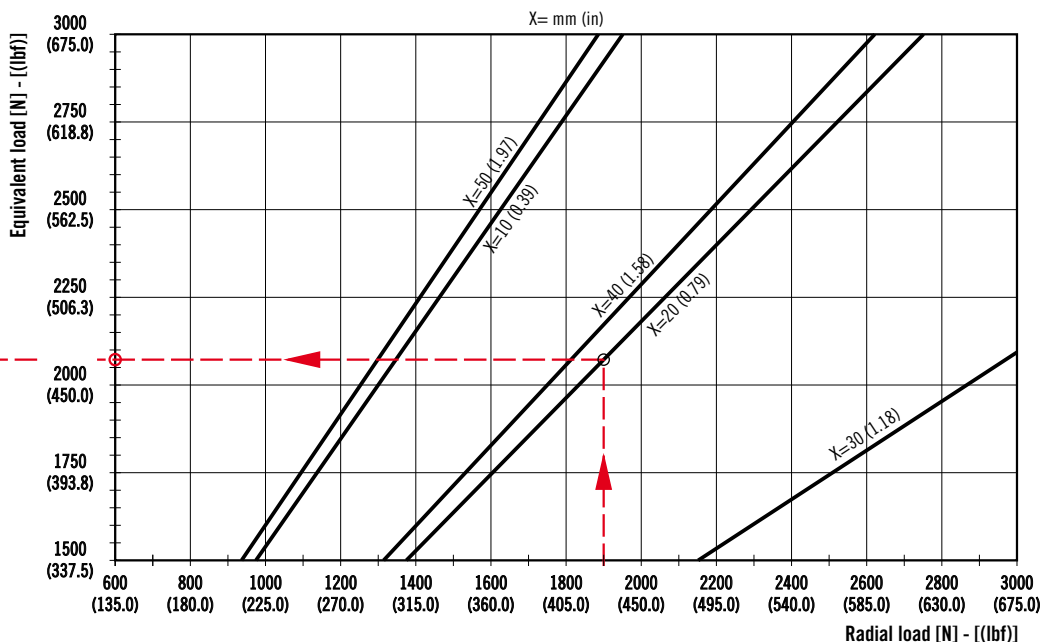

02/07.2006

DIAG034-03-W8

D033-115/0603

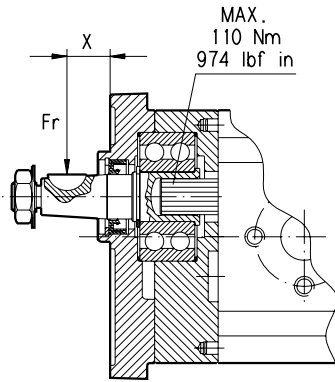

X = Distance of the radial load result from the mounting flange [mm (in)].

Each curve has been obtained at:

- Lubricant oil ISO VG 46
- Temperature 60 °C (140 °F)
- Without axial load
- Contamination level according ISO 281: $\beta_{12}(C) = 200$
- Reliability level of the calculation 90%

Example

| | |
|--------------------|------------------------|
| Fr Radial load | 850 N (191.3 lbf) |
| X | 20 mm (0.79 in) |
| Speed | 2000 min ⁻¹ |
| Rated fatigue life | ≈ 2100 h |

Values shown in the diagrams are indicative only.
Please contact us for more information.

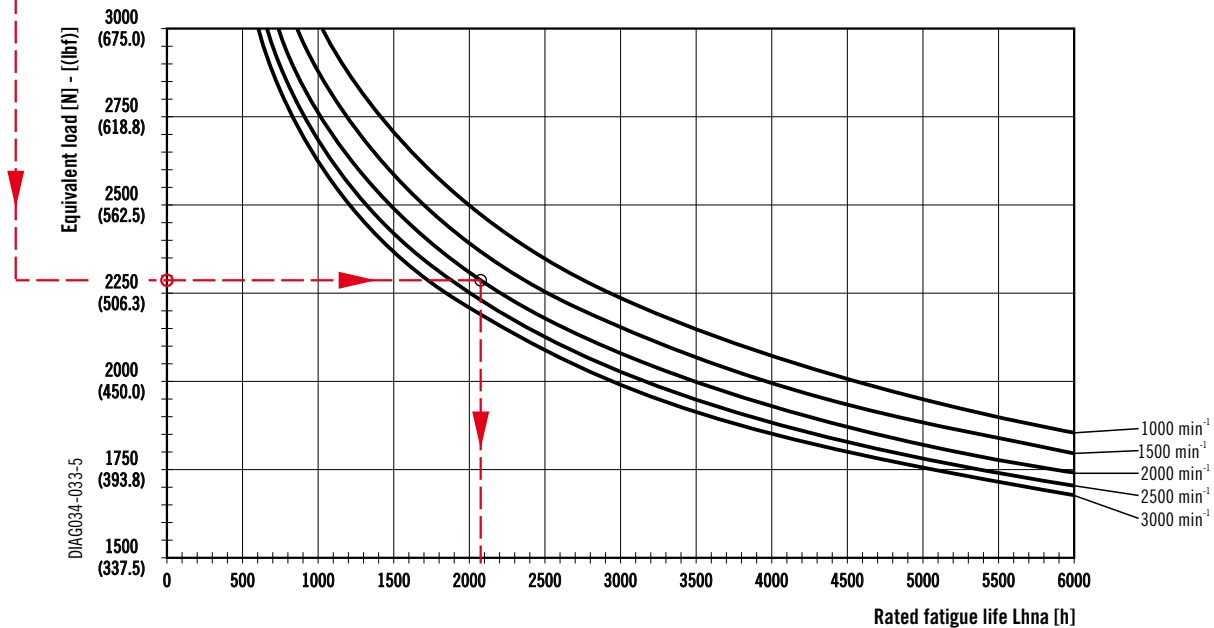
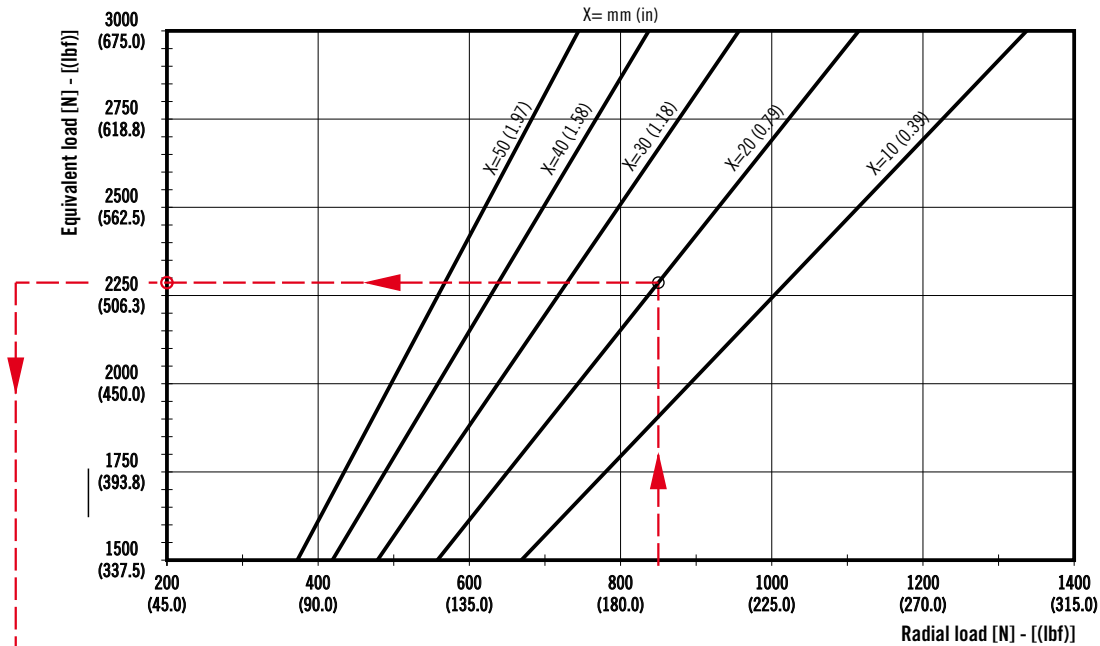

04/10.2020

D033-118/0603

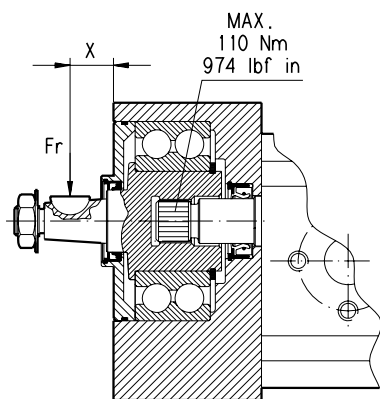

X = Distance of the radial load result from the mounting flange [mm (in)].

Each curve has been obtained at:

- Lubricant oil ISO VG 46
- Temperature 60 °C (140 °F)
- Without axial load
- Contamination level according ISO 281: $\beta_{12}(C) = 200$
- Reliability level of the calculation 90%

Example

| | |
|--------------------|------------------------|
| Fr Radial load | 1900 N (427.5 lbf) |
| X | 20 mm (0.79 in) |
| Speed | 2000 min ⁻¹ |
| Rated fatigue life | ≈ 4600 h |

Values shown in the diagrams are indicative only.
Please contact us for more information.

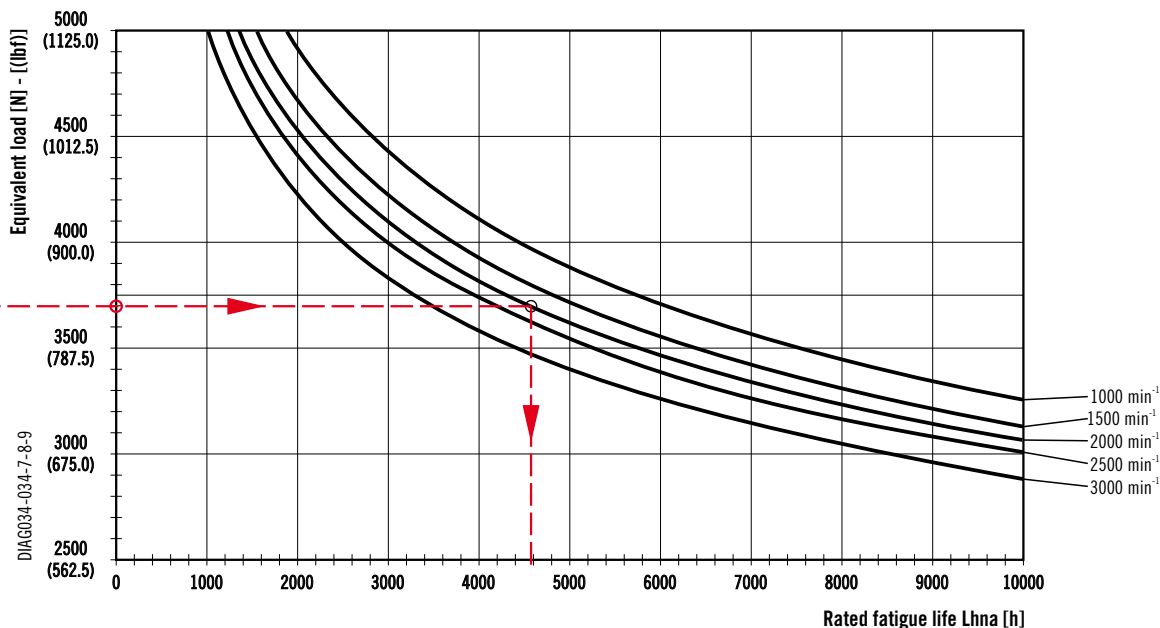
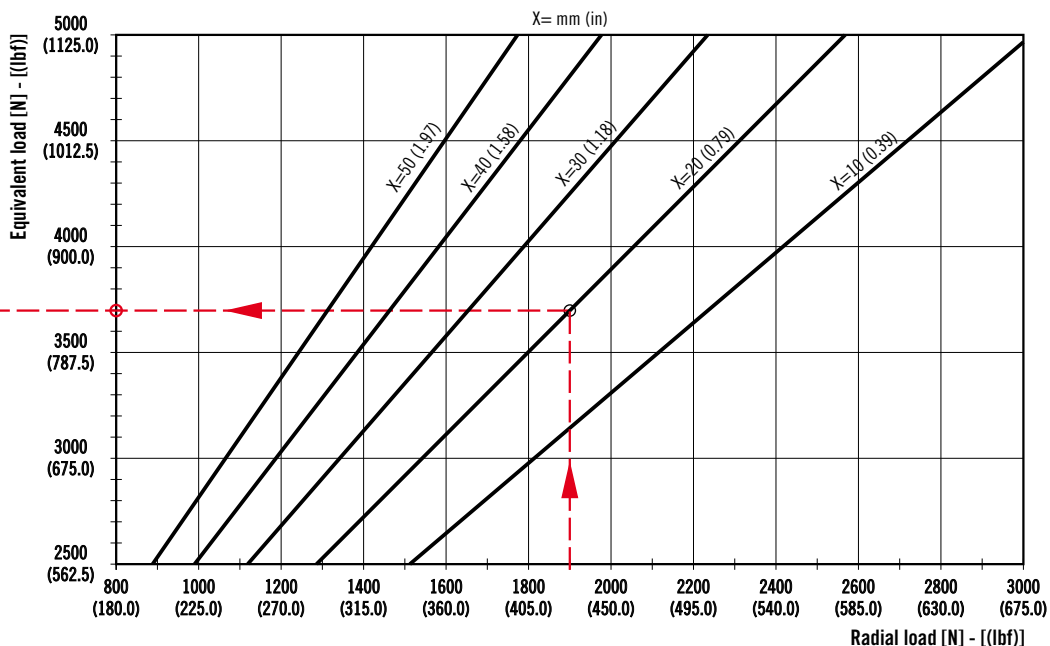

04/10.2020

DIAG034-034-7-8-9

POLARIS 10

DRIVE SHAFTS

EUROPEAN TAPERED 1:8

81

Mounting face refer to flange code **E1**

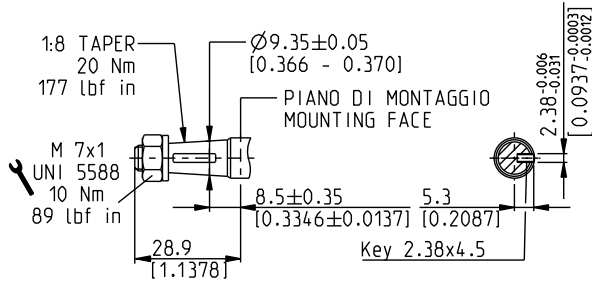

DCAT_033_041

EUROPEAN TAPERED 1:8

86

Mounting face refer to flange code **E7**

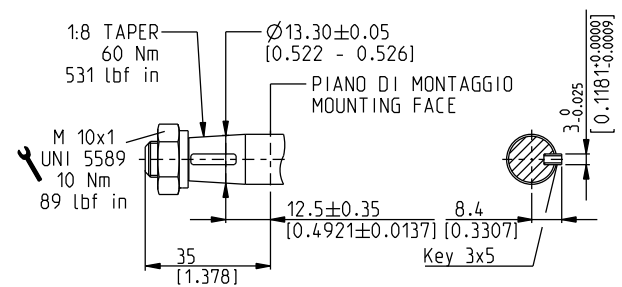

DCAT_033_042

SAE "AA" SPLINE

02

Mounting face refer to flange code **R9**

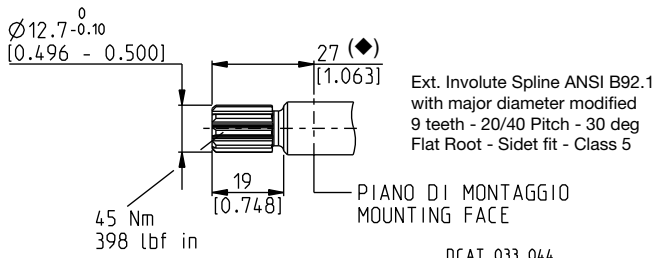

DCAT_033_044

SAE "AA" STRAIGHT

30

Mounting face refer to flange code **S0**

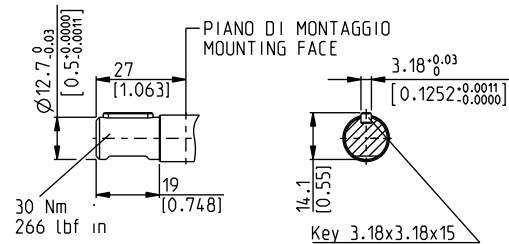

DCAT_033_045

◆ 24 (0.9449) with flange code **S0**

SAE STRAIGHT

36

Not available with size:

10•1,5 10•2,5

Mounting face refer to flange code **R8**

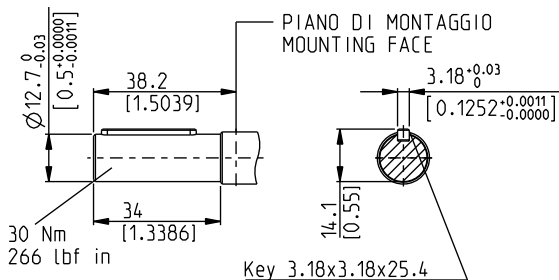

DCAT_033_046

STRAIGHT

29

Not available with size:

10•5,8

Mounting face refer to flange code **E8**

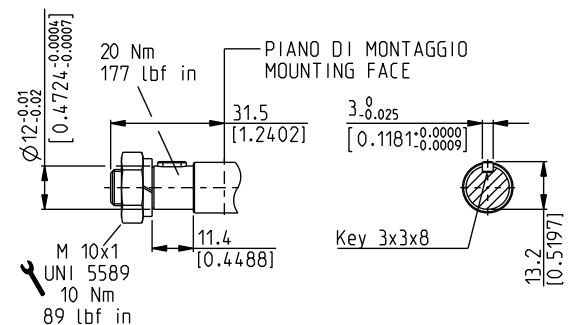

DCAT_033_043

04/10.2020

POLARIS 20

DRIVE SHAFTS

EUROPEAN TAPERED 1:8

82

Not available with size:

20•24,5

Mounting face refer to flange code **E2**

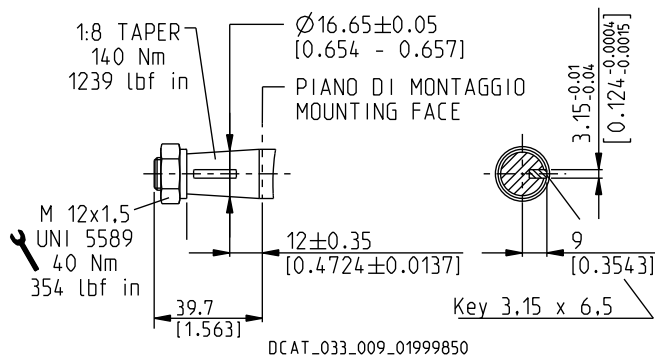

GERMAN TAPERED 1:5

55

Mounting face refer to flange code **B2**

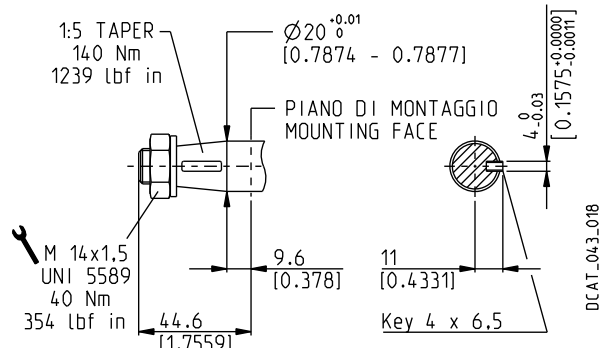

GERMAN TAPERED 1:5

54

Mounting face refer to flange code **B2**

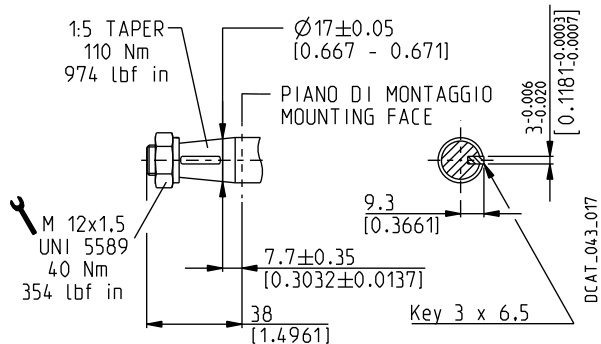

STRAIGHT

46

Not available with size:

20•7,2 20•19 20•24,5 20•27,8

Mounting face refer to flange code **E2**

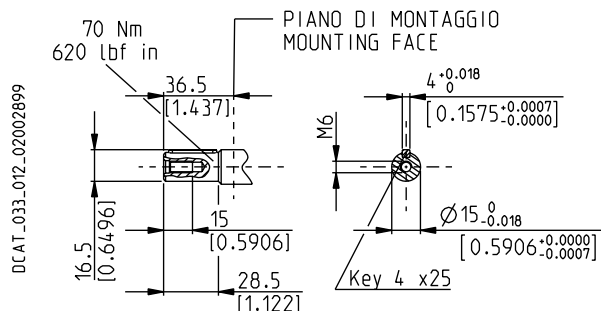

SAE "A" SPLINE

03

Mounting face refer to flange code **S1**

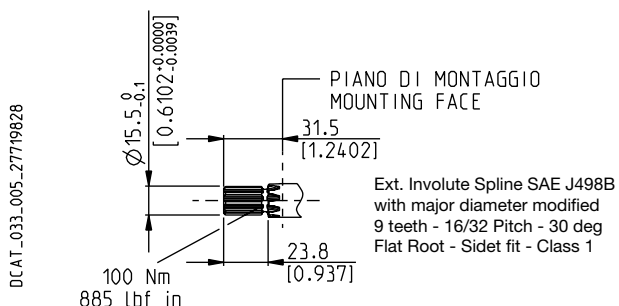

SPLINE

01

Mounting face refer to flange code **S1**

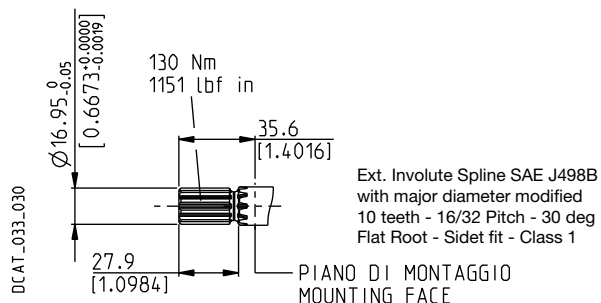

04/10.2020

POLARIS 20

DRIVE SHAFTS

SAE SPLINE

07

Mounting face refer to flange code **S1**

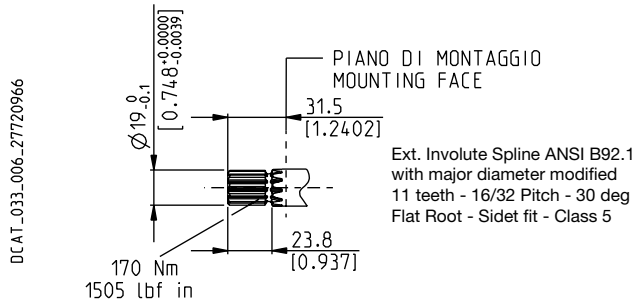

STRAIGHT

49

Not available with size:

20•19 20•24,5

Mounting face refer to flange code **S1**

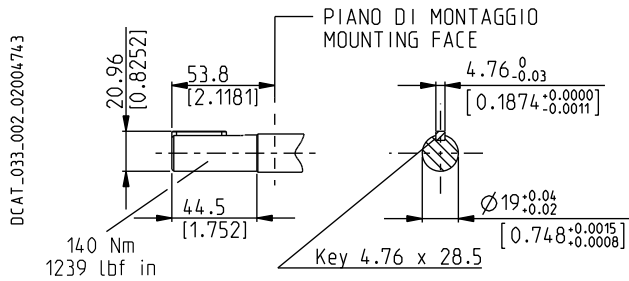

SAE "B" SPLINE

04

Mounting face refer to flange code **S5**

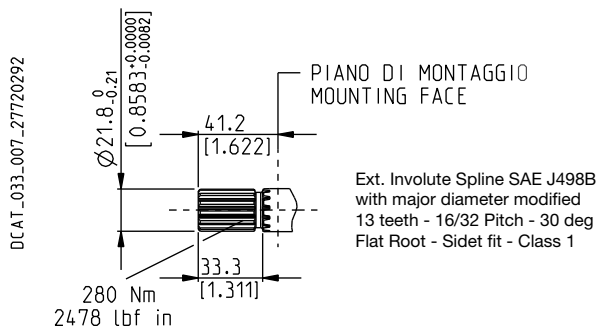

SAE "A" STRAIGHT

31

Not available with size:

20•24,5 20•27,8

Mounting face refer to flange code **S1**

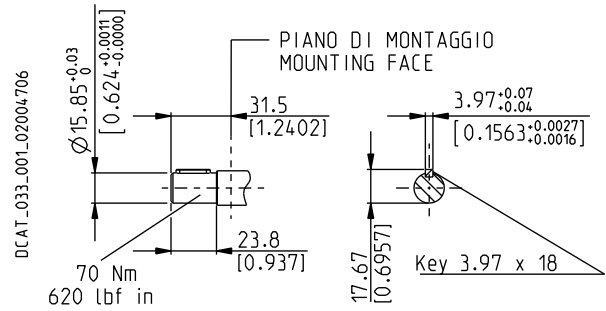

STRAIGHT

50

Mounting face refer to flange code **S1**

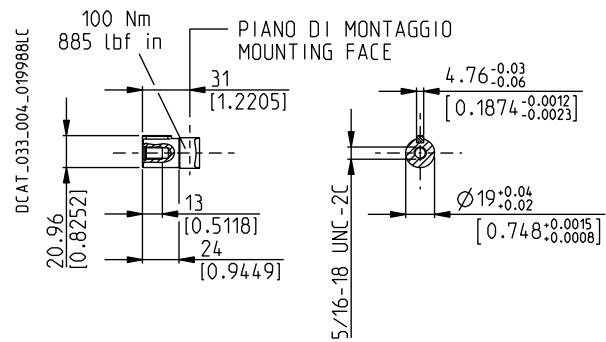

SAE "B" STRAIGHT

32

Not available with size:

20•24,5

Mounting face refer to flange code **S5**

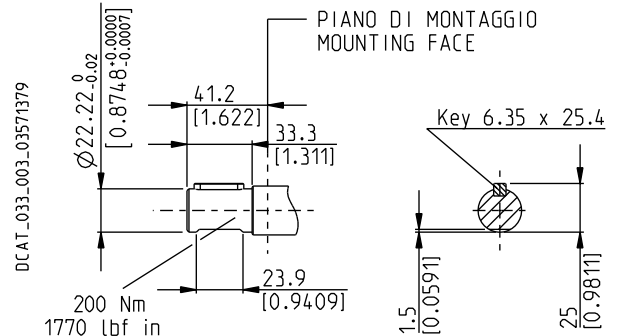

04/10.2020

POLARIS 20

DRIVE SHAFTS

DIN 5482 SPLINE

12

Mounting face refer to flange code **B2**

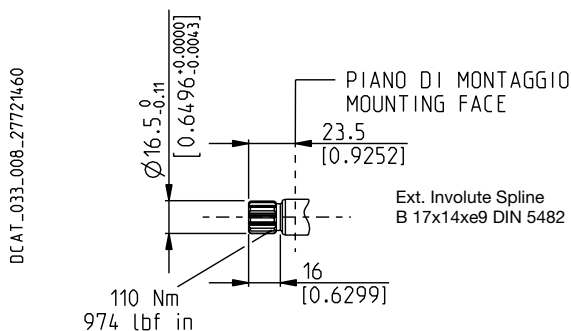

STRAIGHT

48

Only for version 5 with outboard bearing

Available in 0 version only with size:

20•20

Mounting face refer to flange code **E2**

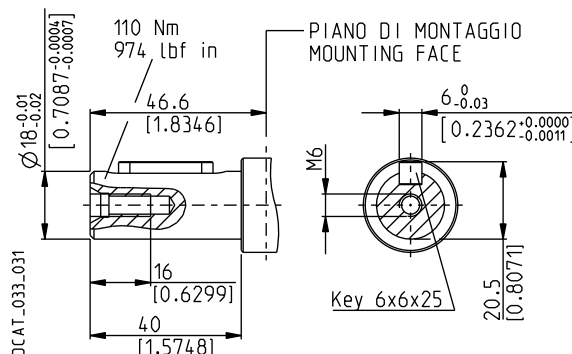

STRAIGHT

B1

Only for version 5 and 8 with outboard bearing

Mounting face refer to flange code **E2**

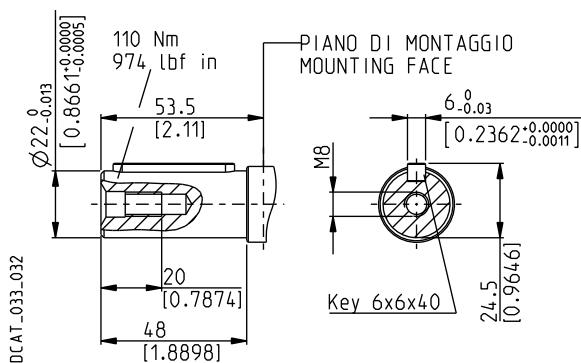

TANG

95

Not available with size:

20•19 20•24,5

Mounting face refer to flange code **B6**

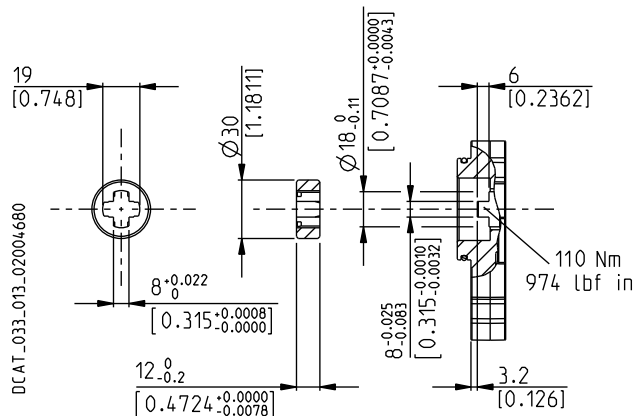

04/10.2020

POLARIS 30

DRIVE SHAFTS

EUROPEAN TAPERED 1:8

83

Not available with size:

30•82 30•90

Mounting face refer to flange code **E3**

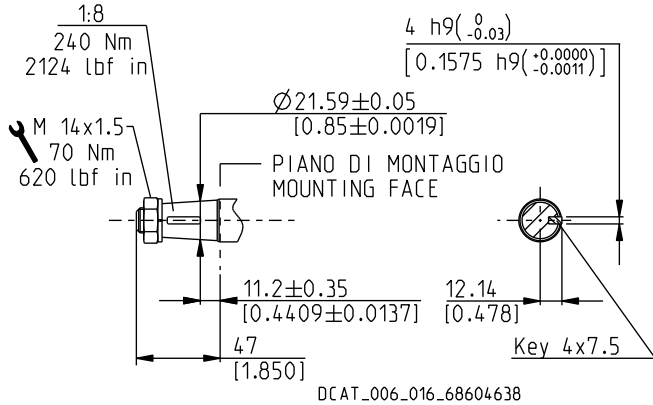

EUROPEAN TAPERED 1:8

84

Not available with size:

30•22 30•34

Mounting face refer to flange code **E4**

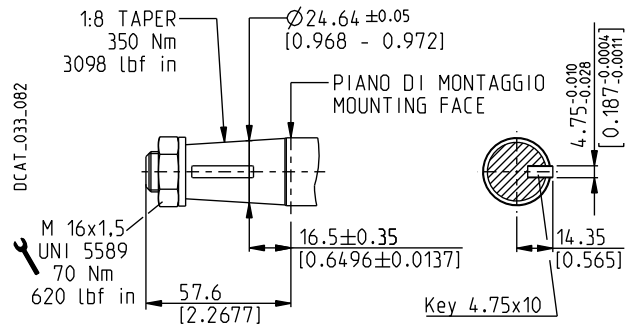

GERMAN TAPERED 1:5

56

Not available with size:

30•61 30•73 30•82 30•90

Mounting face refer to flange code **B3**

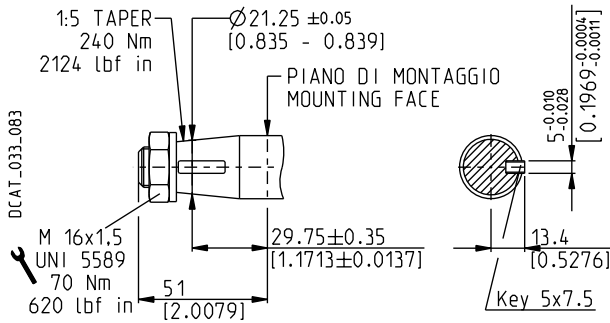

STRAIGHT

41

Not available with size:

30•82 30•90

Mounting face refer to flange code **E3**

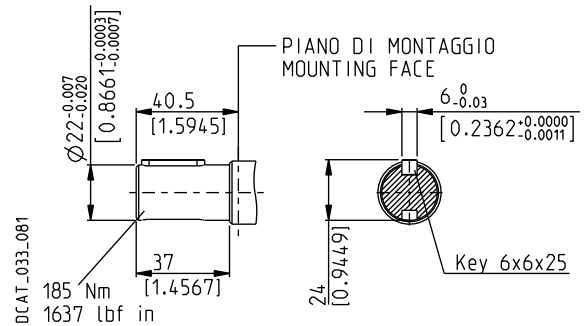

SAE "B" SPLINE

A8

Not available with size:

30•82 30•90

Mounting face refer to flange code **U3**

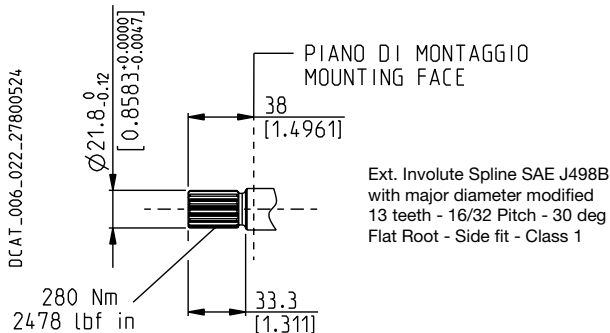

SAE "BB" SPLINE

A5

Mounting face refer to flange code **U3**

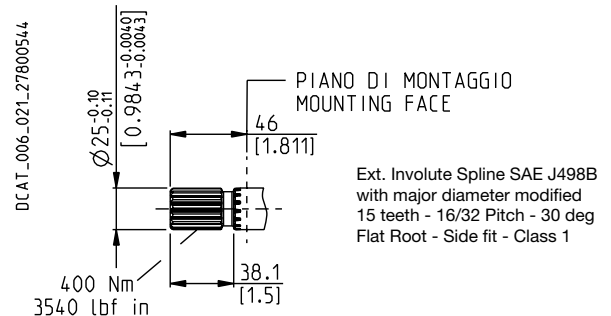

04/10.2020

POLARIS 30

DRIVE SHAFTS

SAE "B" SPLINE

04

Mounting face refer to flange code **S5**

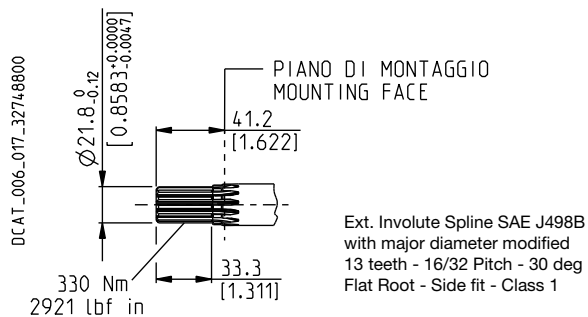

SAE "BB" SPLINE

05

Mounting face refer to flange code **S5**

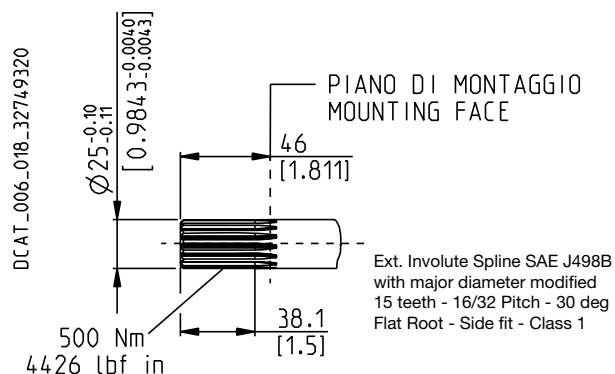

SAE "B" STRAIGHT

32

Mounting face refer to flange code **S5**

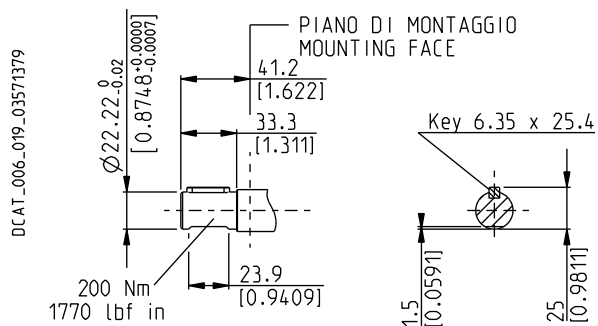

SAE "BB" STRAIGHT

33

Mounting face refer to flange code **S5**

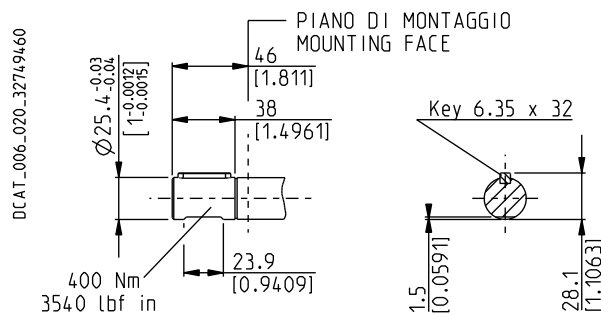

04/10.2020

POLARIS 10

MOUNTING FLANGES AND TABLE OF COMPATIBILITY

EUROPEAN

E1

Material: cast iron and aluminium

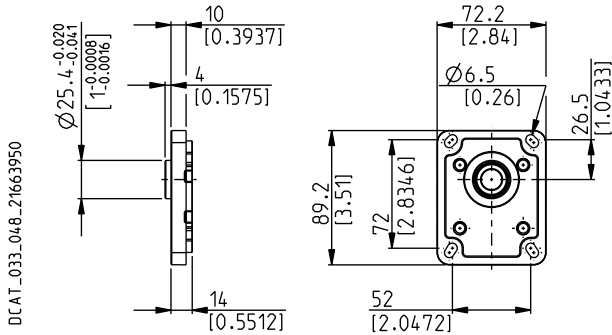

DRIVE SHAFTS
See page 52

| VERSIONS | 81 | 02 | 29 | 86 |
|-------------|----|----|----|----|
| See page 48 | | | | |
| 0 | # | X | X | X |

Standard combination
X Available combination

EUROPEAN

E7

Material: cast iron and aluminium

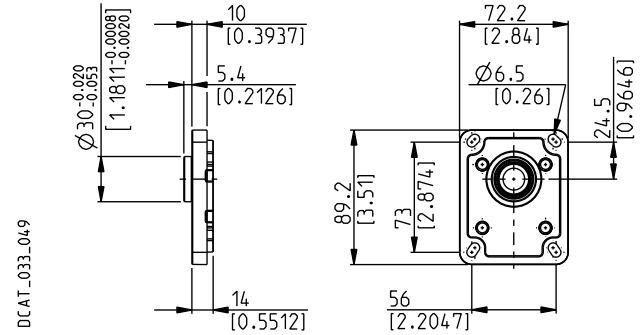

DRIVE SHAFTS
See page 52

| VERSIONS | 86 | 29 | 30 |
|-------------|----|----|----|
| See page 48 | | | |
| 0 | # | X | X |

Standard combination
X Available combination

EUROPEAN

E8

Material: cast iron and aluminium

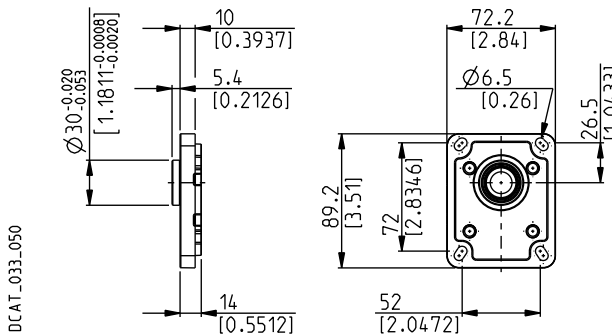

DRIVE SHAFTS
See page 52

| VERSIONS | 29 | 02 |
|-------------|----|----|
| See page 48 | | |
| 0 | # | X |

Standard combination
X Available combination

GERMAN 2 BOLTS

B1

Material: aluminium

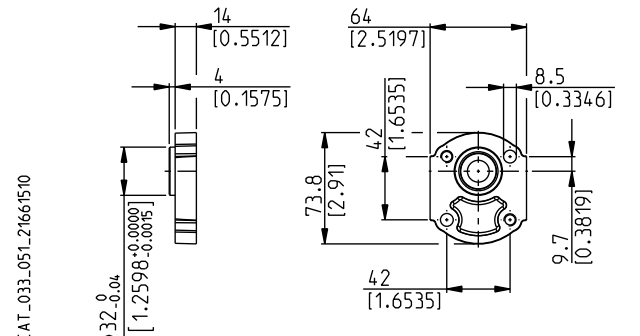

DRIVE SHAFTS
See page 52

| VERSIONS | 30 | 86 |
|-------------|----|----|
| See page 48 | | |
| 0 | # | X |

Standard combination
X Available combination

02/07.2006

POLARIS 10

MOUNTING FLANGES AND TABLE OF COMPATIBILITY

GERMAN 4 BOLTS

K2

Material: aluminium

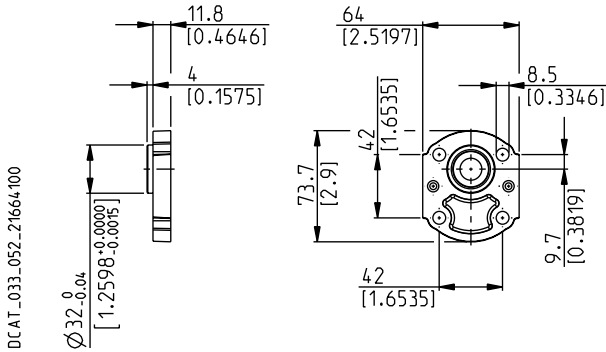

DRIVE SHAFTS
See page 52

| VERSIONS | 02 | 30 |
|-------------|----------|----------|
| See page 48 | | |
| 0 | X | X |

Standard combination
X Available combination

SAE "A-A" 2 BOLTS

S0

Material: cast iron and aluminium

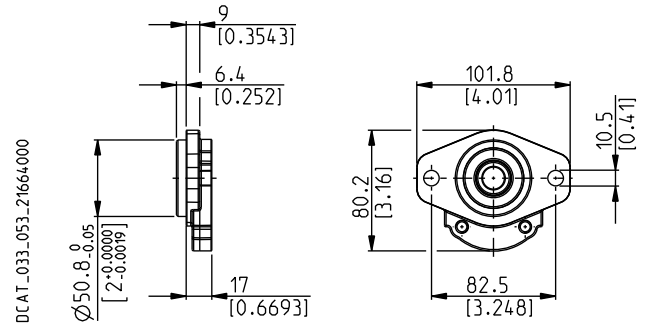

DRIVE SHAFTS
See page 52

| VERSIONS | 30 | 02 | 86 |
|-------------|----------|----------|----------|
| See page 48 | | | |
| 0 | # | X | X |

Standard combination
X Available combination

SAE "A-A" 2-4 BOLTS

R9

Material: cast iron

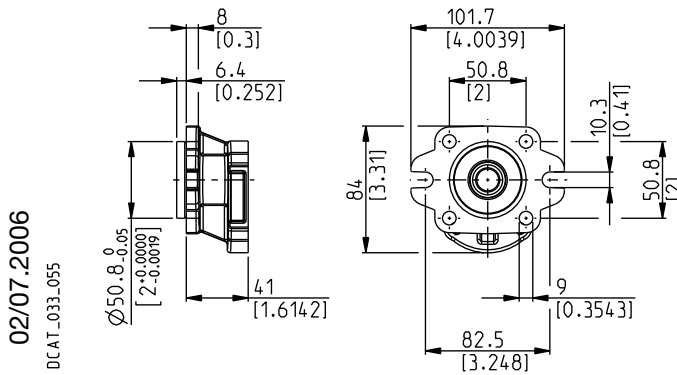

DRIVE SHAFTS
See page 52

| VERSIONS | 02 | 30 | 36 |
|-------------|----------|----------|----------|
| See page 48 | | | |
| 0 | # | X | # |

Standard combination
X Available combination

SAE 2-4 BOLTS

R8

Material: cast iron

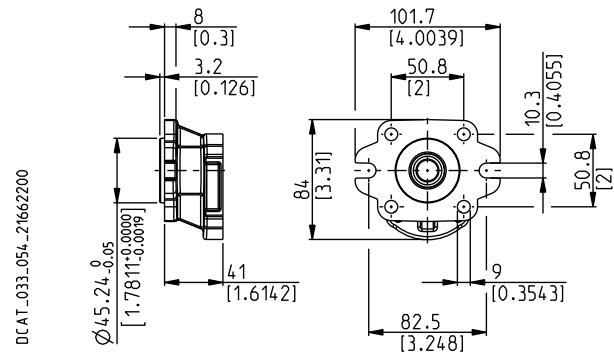

DRIVE SHAFTS
See page 52

| VERSIONS | 02 | 30 | 36 |
|-------------|----------|----------|----------|
| See page 48 | | | |
| 0 | # | X | # |

Standard combination
X Available combination

POLARIS 10

MOUNTING FLANGES AND TABLE OF COMPATIBILITY

SAE 2 BOLTS

W9

Material: cast iron

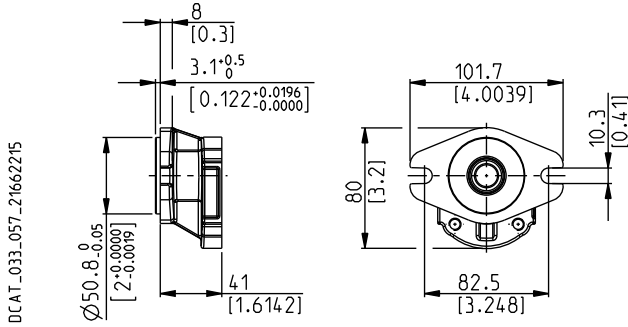

DRIVE SHAFTS

See page 52

VERSIONS

See page 48

36

0

#

Standard combination

X Available combination

POLARIS 20

MOUNTING FLANGES AND TABLE OF COMPATIBILITY

EUROPEAN

E2

Material: cast iron and aluminium

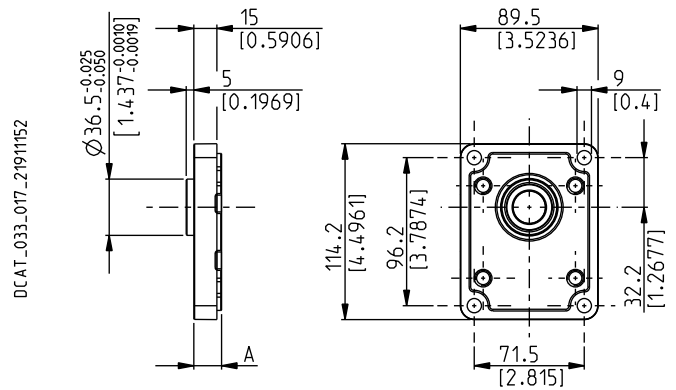

DRIVE SHAFTS

See page 53 ÷ 55

| VERSIONS See page 48 | A mm (in) | 82 | 46 | B1 | 03 | 04 | 07 | 12 | 31 | 48 | 49 | 50 | 54 |
|-------------------------|---------------|----|----|----|----|----|----|----|----|----|----|----|----|
| 0 | 18 (0.7087) | # | # | | X | X | X | X | X | X | X | X | X |
| 5 | 43,6 (1.7165) | # | | X | X | | | | | # | X | X | X |
| 7 | 59,4 (2.3386) | # | | | | | | | | | | | |
| 8 | 59,4 (2.3386) | | | # | | | | | | | | | |

Standard combination

X Available combination

GERMAN

B2

Material: cast iron and aluminium

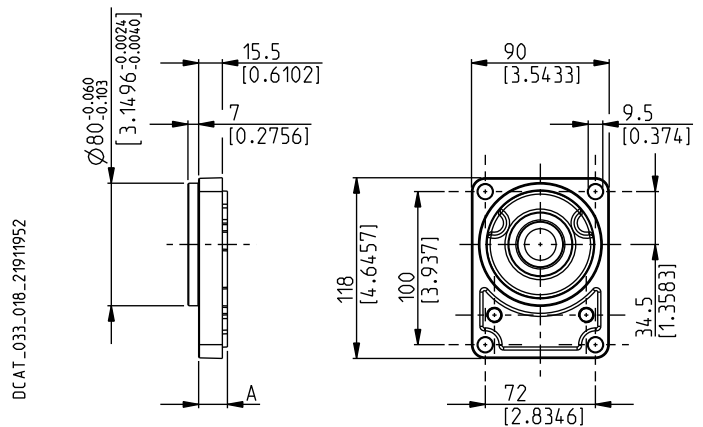

DRIVE SHAFTS

See page 53 ÷ 55

| VERSIONS See page 48 | A mm (in) | 12 | 54 | 55 | 01 | 03 | 31 | 46 | 49 | 82 |
|-------------------------|---------------|----|----|----|----|----|----|----|----|----|
| 0 | 18,8 (0.7402) | # | # | | X | X | X | X | X | X |
| 5 | 44,4 (1.7480) | | X | X | | X | | | X | X |
| 9 | 59,4 (1.7441) | | | X | | | | | | |

Standard combination

X Available combination

04/10.2020

POLARIS 20

MOUNTING FLANGES AND TABLE OF COMPATIBILITY

GERMAN 2 BOLTS

B4

Material: cast iron and aluminium

⊕ Through hole

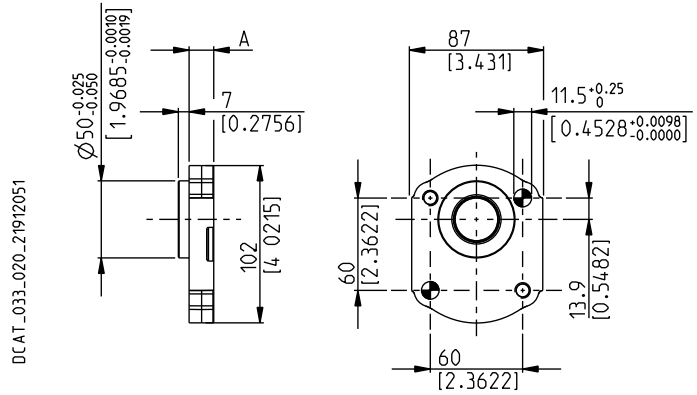

DRIVE SHAFTS

See page 53 ÷ 55

| VERSIONS See page 48 | A mm (in) | 54 | 03 | 12 | 31 | 49 | 82 |
|-------------------------|---------------|----|----|----|----|----|----|
| 0 | 16 (0.63) | # | X | X | X | X | X |
| 5 | 41,6 (1.6378) | X | X | | | X | X |

Standard combination

X Available combination

GERMAN 2 BOLTS

B5

Material: cast iron and aluminium

⊕ Through hole

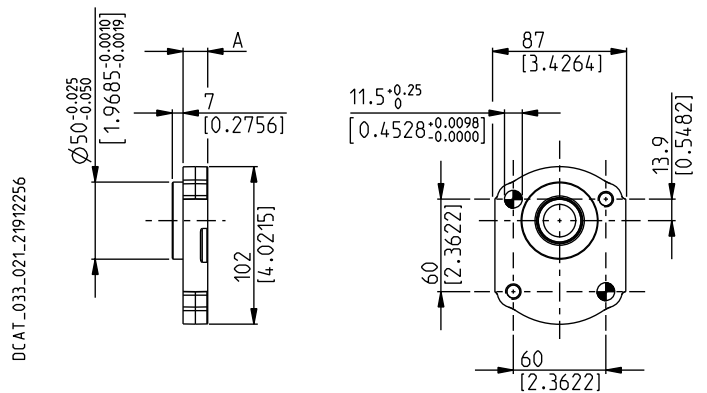

DRIVE SHAFTS

See page 53 ÷ 55

| VERSIONS See page 48 | A mm (in) | 54 | 03 | 12 | 31 | 49 | 82 |
|-------------------------|---------------|----|----|----|----|----|----|
| 0 | 16 (0.63) | # | X | X | X | X | X |
| 5 | 41,6 (1.6378) | X | X | | | X | X |

Standard combination

X Available combination

02/07.2006

POLARIS 20

MOUNTING FLANGES AND TABLE OF COMPATIBILITY

GERMAN 2 BOLTS

U2

Material: cast iron and aluminium

☉ Through hole

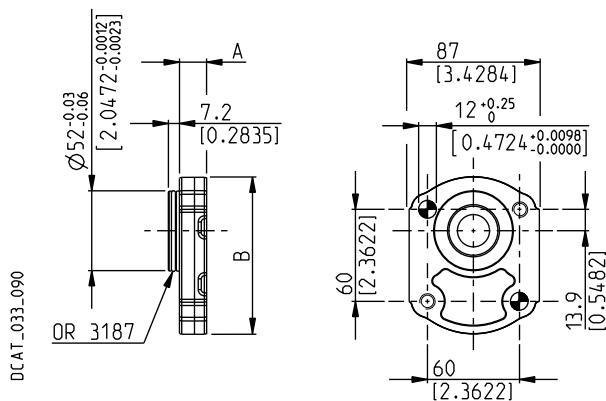

DRIVE SHAFTS

See page 54 ÷ 55

| VERSIONS See page 48 | A mm (in) | B mm (in) | 03 | 54 | 07 |
|-------------------------|---------------|------------------|----|----|----|
| 0 | 17,7 (0.6968) | (◆) 102 (4.0157) | # | | X |
| 5 | 43,3 (1.747) | (●) 105 (4.1339) | | X | |

Standard combination

(◆) Aluminium

X Available combination

(●) Cast iron

GERMAN 4 BOLTS

B6

Material: cast iron and aluminium

☉ Through hole

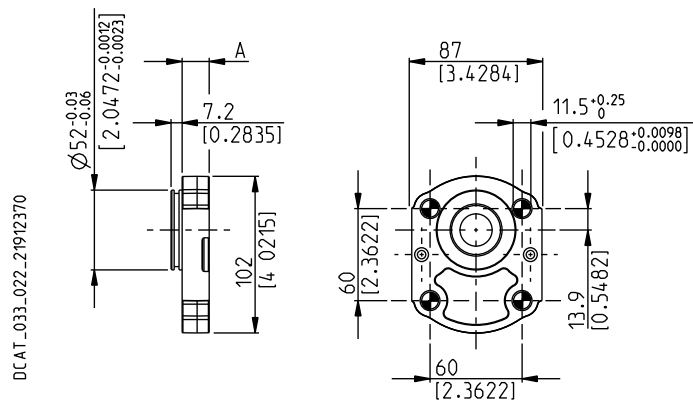

DRIVE SHAFTS

See page 54 ÷ 55

| VERSIONS See page 48 | A mm (in) | 95 | 07 | 12 |
|-------------------------|---------------|----|----|----|
| 0 | 17,7 (0.6968) | # | X | X |
| 5 | 43,3 (1.747) | X | | |

Standard combination

X Available combination

04/10.2020

POLARIS 20

MOUNTING FLANGES AND TABLE OF COMPATIBILITY

SAE "A" 2 BOLTS

S1

Material: cast iron and aluminium

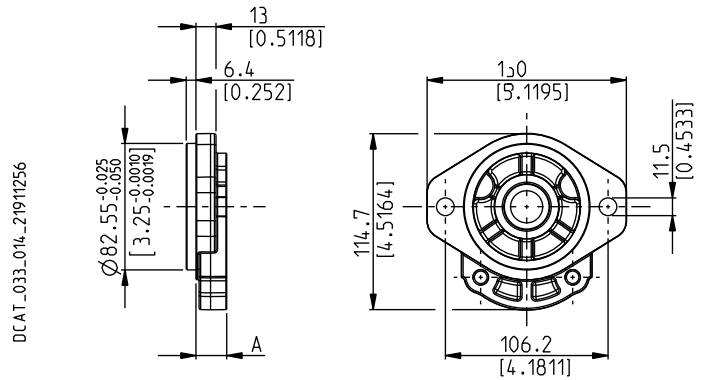

DRIVE SHAFTS

See page 53 ÷ 55

| VERSIONS See page 48 | A mm (in) | 01 | 03 | 04 | 07 | 12 | 31 | 32 | 46 | 49 | 50 | 54 | 82 |
|-------------------------|---------------|----|----|----|----|----|----|----|----|----|----|----|----|
| 0 | 20 (0.787) | # | # | X | # | X | # | X | X | # | X | X | X |
| 5 | 45,6 (1.7953) | | X | | | | | | | X | X | X | X |

Standard combination

X Available combination

SAE "A" 2 BOLTS

S2

Material: cast iron and aluminium

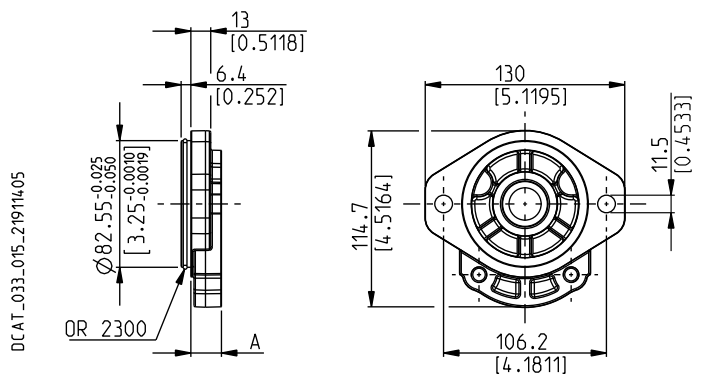

DRIVE SHAFTS

See page 53 ÷ 55

| VERSIONS See page 48 | A mm (in) | 01 | 03 | 04 | 07 | 12 | 31 | 32 | 46 | 49 | 50 | 54 | 82 |
|-------------------------|---------------|----|----|----|----|----|----|----|----|----|----|----|----|
| 0 | 20 (0.7874) | # | # | X | # | X | # | X | X | # | X | X | X |
| 5 | 45,6 (1.7953) | | X | | | | | | | X | X | X | X |

Standard combination

X Available combination

02/07.2006

POLARIS 20

MOUNTING FLANGES AND TABLE OF COMPATIBILITY

SAE "A" 2 BOLTS

S9

Material: cast iron and aluminium

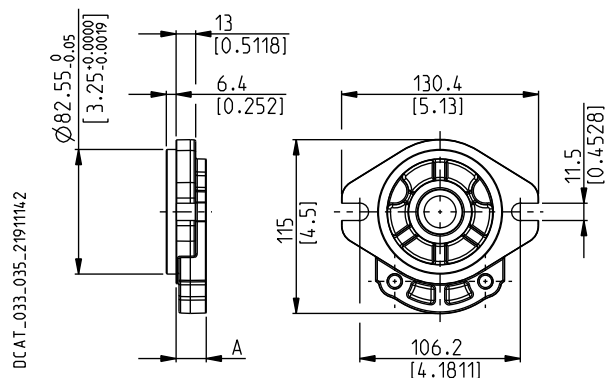

DRIVE SHAFTS

See page 53 ÷ 55

| VERSIONS See page 48 | A mm (in) | 01 | 03 | 04 | 07 | 12 | 31 | 32 | 46 | 49 | 50 | 54 | 82 |
|-------------------------|---------------|----|----|----|----|----|----|----|----|----|----|----|----|
| 0 | 20 (0.7874) | # | # | X | # | X | # | X | X | # | X | X | X |
| 5 | 45,6 (1.7953) | | X | | | | | | | X | X | X | X |

Standard combination

X Available combination

SAE "B" 2 BOLTS

S5

Material: cast iron

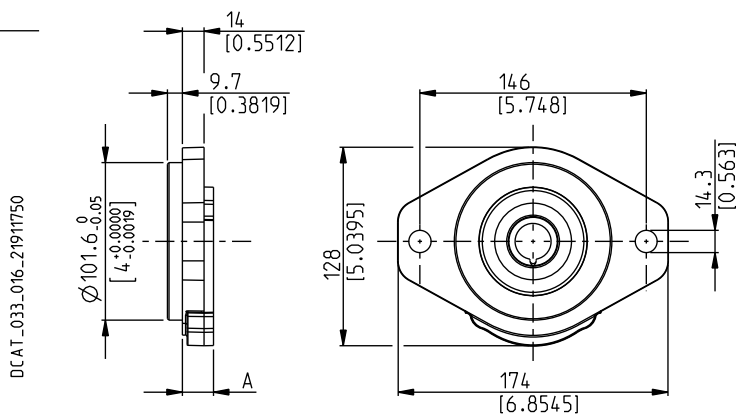

DRIVE SHAFTS

See page 54

| VERSIONS See page 48 | A mm (in) | 04 | 32 | 49 |
|-------------------------|---------------|----|----|----|
| 0 | 20 (0.7874) | # | # | X |
| 5 | 45,6 (1.7953) | | | X |

Standard combination

X Available combination

02/07.2006

POLARIS 20

MOUNTING FLANGES AND TABLE OF COMPATIBILITY

GERMAN

W8

Material: cast iron

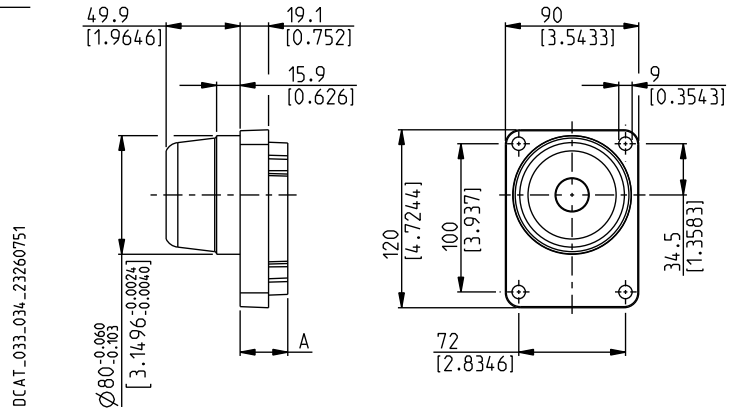

DRIVE SHAFTS

See page 53

VERSIONS

See page 48

A

mm (in)

55

W8

32,1 (1.2638)

#

Standard combination

X Available combination

POLARIS 30

MOUNTING FLANGES AND TABLE OF COMPATIBILITY

EUROPEAN

E3

Material: cast iron

D033-199/0706

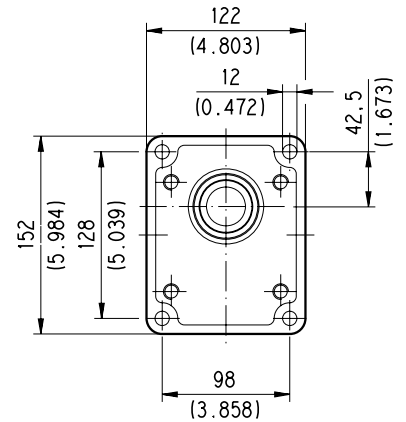
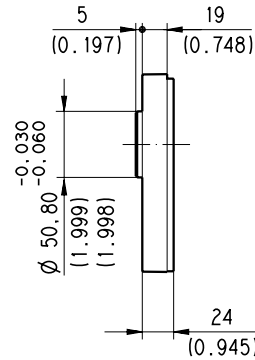

DRIVE SHAFTS

See page 56 ÷ 57

| VERSIONS See page 48 | 83 | 41 | 04 | 05 | 32 | 33 | A5 | A8 |
|-------------------------|-----------|-----------|-----------|-----------|-----------|-----------|-----------|-----------|
| 0 | # | # | X | X | X | X | X | X |

Standard combination

X Available combination

EUROPEAN

E4

Material: cast iron

D033-200/0703

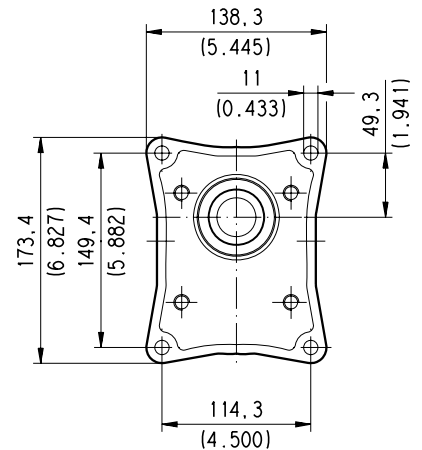
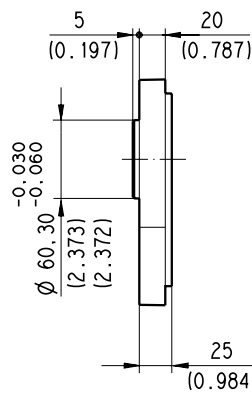

DRIVE SHAFTS

See page 56

| VERSIONS See page 48 | 84 | 41 | A5 | A8 |
|-------------------------|-----------|-----------|-----------|-----------|
| 0 | # | X | X | X |

Standard combination

X Available combination

02/07.2006

POLARIS 30

MOUNTING FLANGES AND TABLE OF COMPATIBILITY

GERMAN

B3

Material: cast iron

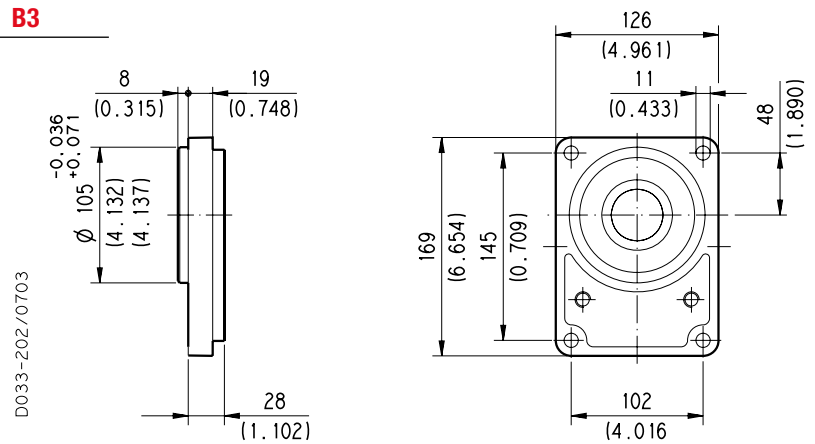

DRIVE SHAFTS
See page 56

| VERSIONS See page 48 | 56 | 83 | A5 | A8 |
|-------------------------|-----------|-----------|-----------|-----------|
| 0 | # | X | X | X |

Standard combination
X Available combination

SAE "B" 2 BOLTS

S5

Material: cast iron

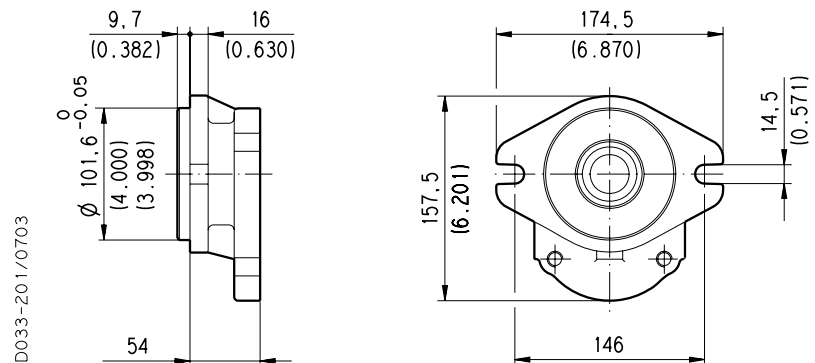

DRIVE SHAFTS
See page 57

| VERSIONS See page 48 | 04 | 05 | 32 | 33 |
|-------------------------|-----------|-----------|-----------|-----------|
| 0 | # | # | # | # |

Standard combination
X Available combination

02/07.2006

POLARIS 30

MOUNTING FLANGES AND TABLE OF COMPATIBILITY

SAE "B" 2 BOLTS

U3

Material: cast iron

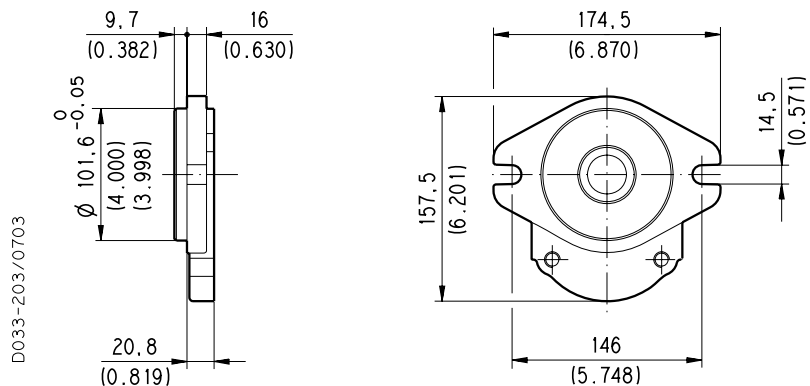

DRIVE SHAFTS
See page 56

| VERSIONS See page 48 | A5 | A8 | 83 |
|--------------------------------|-----------|-----------|-----------|
| 0 | # | # | x |

Standard combination
X Available combination

02/07.2006

PORTS POSITION AND TYPE

| PORTS TYPE | SIDE PORTS | | | | | | | | | | | | REAR PORTS | | | |
|--------------------|------------|-----|----------|-----|-----------|-----|----------|-----|----------|-----|---------|-----|------------|-----|---------|-----|
| | German | | European | | Split SSM | | Spit SSS | | Gas BSPP | | SAE ODT | | Gas BSPP | | SAE ODT | |
| Pump type | IN | OUT | IN | OUT | IN | OUT | IN | OUT | IN | OUT | IN | OUT | IN | OUT | IN | OUT |
| Motor type | OUT | IN | OUT | IN | OUT | IN | OUT | IN | OUT | IN | OUT | IN | OUT | IN | OUT | IN |
| PL. 10•1 | BB | BA | | | | | | | GC | GC | OB | OA | GC | GC | OB | OA |
| PL. 10•1,5 | BB | BA | | | | | | | GC | GC | OB | OA | GC | GC | OB | OA |
| PL. 10•2 | BB | BA | | | | | | | GC | GC | OB | OA | GC | GC | OB | OA |
| PL. 10•2,5 | BB | BA | | | | | | | GC | GC | OB | OA | GC | GC | OB | OA |
| PL. 10•3,15 | BB | BA | | | | | | | GC | GC | OB | OA | GC | GC | OB | OA |
| PL. 10•4 | BB | BA | | | | | | | GC | GC | OB | OA | GC | GC | OB | OA |
| PL. 10•5 | BB | BA | | | | | | | GD | GD | OB | OA | GD | GD | OB | OA |
| PL. 10•5,8 | BB | BA | | | | | | | GD | GD | OB | OA | GD | GD | OB | OA |
| PL. 10•6,3 | BB | BA | | | | | | | GD | GD | OB | OA | GD | GD | OB | OA |
| PL. 10•8 | BB | BA | | | | | | | GD | GD | OC | OB | GD | GD | OB | OB |
| PL. 10•10 | BB | BA | | | | | | | GD | GD | OC | OB | GD | GD | OB | OB |
| PL. 20•4 | BE | BC | EA | EA | MA | MA | SA | SA | GD | GD | OC | OC | GD | GD | OC | OC |
| PL. 20•6,3 | BE | BC | EA | EA | MA | MA | SA | SA | GD | GD | OC | OC | GD | GD | OC | OC |
| PL. 20•7,2 | BE | BC | EA | EA | MA | MA | SA | SA | GD | GD | OC | OC | GD | GD | OC | OC |
| PL. 20•8 | BE | BC | EA | EA | MA | MA | SA | SA | GD | GD | OC | OC | GD | GD | OC | OC |
| PL. 20•9 | BE | BC | EA | EA | MA | MA | SA | SA | GD | GD | OC | OC | GD | GD | OC | OC |
| PL. 20•10,5 | BE | BC | EA | EA | MA | MA | SA | SA | GD | GD | OC | OC | GD | GD | OC | OC |
| PL. 20•11,2 | BE | BC | EA | EA | MA | MA | SA | SA | GD | GD | OC | OC | GD | GD | OC | OC |
| PL. 20•14 | BE | BC | EB | EA | MB | MA | SB | SA | GE | GD | OD | OC | GE | GD | OD | OC |
| PL. 20•16 | BE | BC | EB | EA | MB | MA | SB | SA | GE | GD | OD | OC | GE | GD | OD | OC |
| PL. 20•19 | BE | BC | EB | EA | MB | MA | SB | SA | GE | GD | OD | OC | GE | GD | OD | OC |
| PL. 20•20 | BE | BC | EB | EA | MB | MA | SB | SA | GE | GD | OD | OC | GE | GD | OD | OC |
| PL. 20•24,5 | BE | BC | EB | EA | MC | MB | SC | SB | GE | GD | OD | OC | GE | GD | OD | OC |
| PL. 20•25 | BE | BC | EB | EA | MC | MB | SC | SB | GE | GD | OD | OC | GE | GD | OD | OC |
| PL. 20•27,8 | BE | BC | EB | EA | MC | MB | SC | SB | GE | GD | OD | OC | GE | GD | OD | OC |
| PL. 20•31,5 | BE | BC | EB | EA | MC | MB | SC | SB | GE | GD | OD | OC | GE | GD | OD | OC |
| PL. 30•22 | BM | BL | ED | EB | MB | MA | SB | SA | GF | GF | OF | OD | | | | |
| PL. 30•27 | BM | BL | ED | EB | MC | MB | SC | SB | GF | GF | OF | OD | | | | |
| PL. 30•34 | BM | BL | ED | EB | MC | MB | SC | SB | GF | GF | OF | OD | | | | |
| PL. 30•38 | BM | BL | ED | EB | MD | MC | SD | SC | GF | GF | OG | OF | | | | |
| PL. 30•43 | BM | BL | ED | EB | MD | MC | SD | SC | GF | GF | OG | OF | | | | |
| PL. 30•51 | BM | BL | ED | EB | MD | MC | SD | SC | GF | GF | OG | OF | | | | |
| PL. 30•61 | BM | BL | ED | EB | ME | MD | SE | SD | GG | GF | OH | OG | | | | |
| PL. 30•73 | BM | BL | EF | ED | ME | MD | SE | SD | GG | GF | OH | OG | | | | |
| PL. 30•82 | BM | BL | EF | ED | ME | MD | SE | SD | GH | GG | OH | OG | | | | |
| PL. 30•90 | BM | BL | EF | ED | MF | ME | SF | SE | GH | GG | OH | OG | | | | |

01/10.2003

EXTERNAL DRAIN PORTS

| IN/OUT PORTS TYPE | SIDE PORTS | | | | | | REAR PORTS | |
|-------------------|------------|----------|-----------|----------|----------|---------|------------|---------|
| | German | European | Split SSM | Spit SSS | Gas BSPP | SAE ODT | Gas BSPP | SAE ODT |
| PL. 10 | GA | - | - | - | GA | 03 | GA | 03 |
| PL. 20 | TA | GB | GB | 03 | GB | 03 | GB | 03 |
| PL. 30 | GC | GC | GC | OA | GC | OA | - | - |

DRAIN PORTS SIZES

 Tightening torque for low pressure side port

GAS STRAIGHT THREAD PORTS

BSPP

British standard pipe parallel (55°) conforms to UNI - ISO 228

| CODE | NOMINAL SIZE | A | Ø B | Ø C | D | E |  Nm (lbf in) |
|-----------|--------------|-------|------------------|------------------|----------------|-----------------|---|
| | | | mm (in) | mm (in) | mm (in) | mm (in) | |
| GA | 1/8" | G 1/8 | 16,5 (0.6496) | 8,75 (0.3444) | 12 (0.4724) | 1 (0.0394) | 5 ^{+0,25} (44 ÷ 46) |
| GB | 1/4" | G 1/4 | 21,5 (0.8465) | 12 (0.4724) | 15 (0.5906) | 1,5 (0.0591) | 15 ⁺¹ (133 ÷ 142) |

DCAT_006_026_21064779

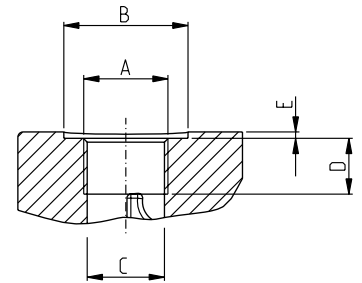

METRIC STRAIGHT THREAD PORTS ISO 6149

METRIC

Metric thread ISO 60° conforms to ISO/R 262

| CODE | A | Ø B | Ø C | D | E |  Nm (lbf in) |
|-----------|--------|----------------|---------------|----------------|-----------------|---|
| | | mm (in) | mm (in) | mm (in) | mm (in) | |
| TA | M 10x1 | 22 (0.8661) | 9 (0.3543) | 13 (0.5118) | 0,5 (0.0197) | 10 ^{+0,5} (89 ÷ 93) |

DCAT_006_027_21060524

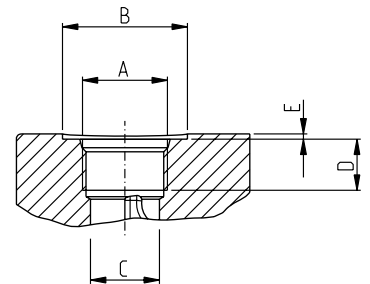

SAE STRAIGHT THREAD PORTS J514

ODT

American straight UNC-UNF 60° conforms to ANSI B 1.1

| CODE | A | Ø B | Ø C | D | E |  Nm (lbf in) |
|-----------|-----------------|----------------|-----------------|----------------|---------------|---|
| | | mm (in) | mm (in) | mm (in) | mm (in) | |
| 03 | 7/16"-20 UNF-2B | 21 (0.8267) | 9,5 (0.3740) | 14 (0.5512) | 1 (0.0394) | 12 ⁺¹ (106 ÷ 115) |

Other drain ports are shown on subsequent pages.

01/10.2003

PORTS SIZE

 Tightening torque for low pressure side port.



 Tightening torque for high pressure side port.

For reversible rotation, please consult only the tightening torque for high pressure side port.

GERMAN FLANGED PORTS - 4 Bolts

GERMAN

Metric thread ISO 60° conforms to ISO/R 262

| CODE | A | B | C |  |  |
|-----------|----------------|----------------|-------------------------|---|---|
| | mm (in) | mm (in) | Thread Depth mm (in) | Nm (lbf in) | Nm (lbf in) |
| BA | 8 (0.3150) | 30 (1.1811) | M6 12 (0.4724) | 8 ^{+0,5} (71 ÷ 75) | 8 ^{+0,5} (71 ÷ 75) |
| BB | 13 (0.5118) | 30 (1.1811) | M6 12 (0.4724) | 8 ^{+0,5} (71 ÷ 75) | 8 ^{+0,5} (71 ÷ 75) |
| BC | 15 (0.5906) | 35 (1.3780) | M6 12 (0.4724) | 8 ^{+0,5} (71 ÷ 75) | 8 ^{+0,5} (71 ÷ 75) |
| BE | 20 (0.7874) | 40 (1.5748) | M6 12 (0.4724) | 8 ^{+0,5} (71 ÷ 75) | 8 ^{+0,5} (71 ÷ 75) |
| BL | 19 (0.7480) | 55 (2.1654) | M8 18 (0.7087) | 15 ⁺¹ (133 ÷ 142) | 20 ⁺¹ (177 ÷ 186) |
| BM | 27 (1.0630) | 55 (2.1654) | M8 18 (0.7087) | 15 ⁺¹ (133 ÷ 142) | 20 ⁺¹ (177 ÷ 186) |

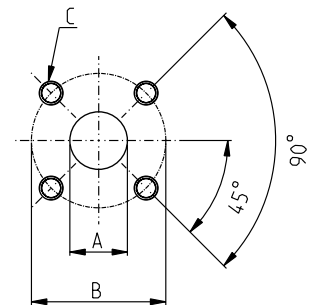

DCAT_033_028_17661888



EUROPEAN FLANGED PORTS - 4 Bolts

EUROPEAN

Metric thread ISO 60° conforms to ISO/R 262

| CODE | A | B | C |  |  |
|-----------|----------------|----------------|-------------------------|---|---|
| | mm (in) | mm (in) | Thread Depth mm (in) | Nm (lbf in) | Nm (lbf in) |
| EA | 13 (0.5118) | 30 (1.1811) | M 6 | 8 ^{+0,5} | 8 ^{+0,5} |
| | | | M 8 | 15 ⁺¹ | 15 ⁺¹ |
| EB | 19 (0.7480) | 40 (1.5748) | M 8 | 15 ⁺¹ | 15 ⁺¹ |
| | | | M 8 (◆) | 15 ⁺¹ (◆) | 15 ⁺¹ (◆) |
| | | | M 8 (◆) | 15 ⁺¹ (◆) | 15 ⁺¹ (◆) |
| ED | 27 (1.0630) | 51 (2.0079) | M 10 | 20 ⁺¹ | 35 ^{+2,5} |
| | | | M 12 | 25 ⁺¹ | 50 ^{+2,5} |
| EF | 33 (1.2992) | 62 (2.4409) | M 12 | 25 ⁺¹ | 50 ^{+2,5} |

(◆) For POLARIS 30

DCAT_006_024_21060533

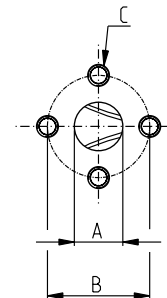

01/10.2003

PORTS SIZES

Tightening torque for low pressure side port.

Tightening torque for high pressure side port.

For reversible rotation, please consult only the tightening torque for high pressure side port.

SAE FLANGED PORTS J518 - Standard pressure series 3000 PSI

SSM

Metric thread ISO 60° to ISO/R 262

| CODE | A | B | C | D | | |
|-----------|------------------|------------------|------------------|-------------------------|----------------------|------------------------|
| | mm (in) | mm (in) | mm (in) | Thread Depth mm (in) | Nm (lbf in) | Nm (lbf in) |
| MA | 12,5 (0.4921) | 38,1 (1.50) | 17,5 (0.6890) | M 8 | 15 ⁺¹ | 15 ⁺¹ |
| | | | | 14 (0.5512) | (133 ÷ 142) | (133 ÷ 142) |
| | | | | M 8 (◆) | 20 ⁺¹ (◆) | 20 ⁺¹ (◆) |
| MB | 19 (0.7480) | 47,6 (1.8740) | 22,2 (0.8740) | M 10 | 20 ⁺¹ | 25 ⁺¹ |
| | | | | 14 (0.5512) | (177 ÷ 186) | (266 ÷ 288) |
| | | | | M 10 (◆) | 20 ⁺¹ (◆) | 35 ^{+2,5} (◆) |
| MC | 25,4 (1.0000) | 52,4 (2.0630) | 26,2 (1.0315) | M 10 | 20 ⁺¹ | 25 ⁺¹ |
| | | | | 14 (0.5512) | (177 ÷ 186) | (266 ÷ 288) |
| | | | | M 10 (◆) | 20 ⁺¹ (◆) | 35 ^{+2,5} (◆) |
| MD | 30,5 (1.2008) | 58,7 (2.3110) | 30,2 (1.1890) | M 10 | 20 ⁺¹ | 30 ^{+2,5} |
| | | | | 15 (0.5906) | (177 ÷ 186) | (266 ÷ 288) |
| | | | | M 10 (◆) | 20 ⁺¹ (◆) | 35 ^{+2,5} (◆) |
| ME | 39,3 (1.5472) | 69,8 (2.7480) | 35,7 (1.4055) | M 12 | 30 ^{+2,5} | 60 ⁺⁵ |
| | | | | 22 (0.8661) | (266 ÷ 288) | (531 ÷ 575) |
| MF | 51 (2.0079) | 77,8 (3.0630) | 42,9 (1.6890) | M 12 | 30 ^{+2,5} | 60 ⁺⁵ |
| | | | | 22 (0.8661) | (266 ÷ 288) | (531 ÷ 575) |

(◆) For POLARIS 30

DCAT_006_025_21064252

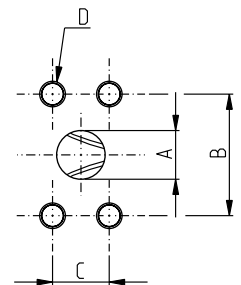

SAE FLANGED PORTS J518 - Standard pressure series 3000 PSI

SSS

American straight thread UNC-UNF 60° conforms to ANSI B 1.1

| CODE | A | B | C | D | | |
|-----------|------------------|------------------|------------------|-------------------------|------------------------|------------------------|
| | mm (in) | mm (in) | mm (in) | Thread Depth mm (in) | Nm (lbf in) | Nm (lbf in) |
| SA | 12,5 (0.4921) | 38,1 (1.50) | 17,5 (0.6890) | 5/16-18 UNC-2B | 15 ⁺¹ | 15 ⁺¹ |
| | | | | 14 (0.5512) | (133 ÷ 142) | (133 ÷ 142) |
| | | | | 5/16-18 UNC-2B (◆) | 20 ⁺¹ (◆) | 20 ⁺¹ (◆) |
| SB | 19 (0.7480) | 47,6 (1.8740) | 22,2 (0.8740) | 3/8-16 UNC-2B | 20 ⁺¹ | 20 ⁺¹ |
| | | | | 14 (0.5512) | (177 ÷ 186) | (177 ÷ 186) |
| | | | | 3/8-16 UNC-2B (◆) | 30 ^{+2,5} (◆) | 20 ⁺¹ (◆) |
| SC | 25,4 (1.0000) | 52,4 (2.0630) | 26,2 (1.0315) | 3/8-16 UNC-2B | 20 ⁺¹ | 25 ⁺¹ |
| | | | | 14 (0.5512) | (177 ÷ 186) | (221 ÷ 230) |
| | | | | 3/8-16 UNC-2B (◆) | 20 ⁺¹ (◆) | 30 ^{+2,5} (◆) |
| SD | 30,5 (1.2008) | 58,7 (2.3110) | 30,2 (1.1890) | 7/16-14 UNC-2B | 20 ⁺¹ | 45 ^{+2,5} |
| | | | | 22 (0.8661) | (177 ÷ 186) | (398 ÷ 420) |
| SE | 39,3 (1.5472) | 69,8 (2.7480) | 35,7 (1.4055) | 1/2-13 UNC-2B | 30 ^{+2,5} | 70 ⁺⁵ |
| | | | | 22 (0.8661) | (266 ÷ 288) | (620 ÷ 664) |
| SF | 51 (2.0079) | 77,8 (3.0630) | 42,9 (1.6890) | 1/2-13 UNC-2B | 30 ^{+2,5} (◆) | 70 ⁺⁵ |
| | | | | 22 (0.8661) | (266 ÷ 288) | (620 ÷ 664) |

(◆) For POLARIS 30

DCAT_006_028_21060740

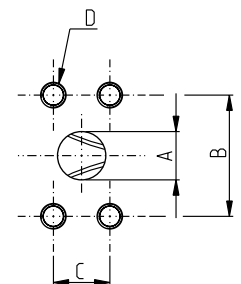

01/10.2003

PORTS SIZE



Tightening torque for low pressure side port.



Tightening torque for high pressure side port.



For reversible rotation, please consult only the tightening torque for high pressure side port.

GAS STRAIGHT THREAD PORTS

BSPP

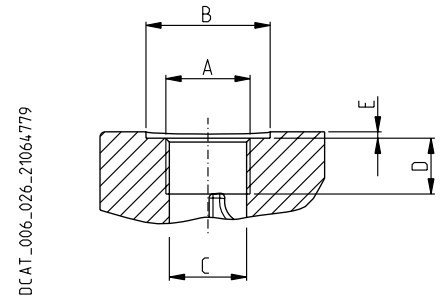
British standard pipe parallel (55°) conforms to UNI - ISO 228



| CODE | Nominal size | A | Ø B | Ø C | D | E |  |  |
|-----------|--------------|---------|--------------------|------------------|--------------------|-------------------|---|---|
| | | | mm (in) | mm (in) | mm (in) | mm (in) | Nm (lbf in) | Nm (lbf in) |
| GC | 3/8" | G 3/8 | 30 (#) (1.1811) | 15 (0.5906) | 10 (#) (0.3937) | 2 (#) (0.0787) | 15 ⁺¹ (#) (133 ÷ 142) | — |
| | | | — | — | 14 (0.5512) | — | 15 ⁺¹ (133 ÷ 142) | 25 ⁺¹ (221 ÷ 230) |
| GD | 1/2" | G 1/2 | — | 19 (0.7480) | 14 (0.5512) | — | 20 ⁺¹ (177 ÷ 186) | 50 ^{+2.5} (443 ÷ 465) |
| | | | — | — | 17 (◆) (0.6693) | — | — | — |
| GE | 3/4" | G 3/4 | — | 24,5 (0.9646) | 18 (0.7087) | — | 30 ^{+2.5} (266 ÷ 288) | 90 ⁺⁵ (797 ÷ 841) |
| GF | 1" | G 1 | — | 30,5 (1.2008) | 18 (0.7086) | — | 50 ^{+2.5} (443 ÷ 465) | 130 ⁺¹⁰ (1151 ÷ 1239) |
| GG | 1" 1/4 | G 1 1/4 | — | 39 (1.5354) | 22 (0.8661) | — | 60 ⁺⁵ (531 ÷ 575) | 170 ⁺¹⁰ (1505 ÷ 1593) |
| GH | 1" 1/2 | G 1 1/2 | — | 45 (1.7716) | 24 (0.9448) | — | 70 ⁺⁵ (620 ÷ 664) | 210 ⁺¹⁵ (1859 ÷ 1992) |

(#) = Drain port

(◆) For POLARIS 20

02/07.2006

PORTS SIZES

 Tightening torque for low pressure side port.

 Tightening torque for high pressure side port.



For reversible rotation, please consult only the tightening torque for high pressure side port.

SAE STRAIGHT THREAD PORTS J514

ODT

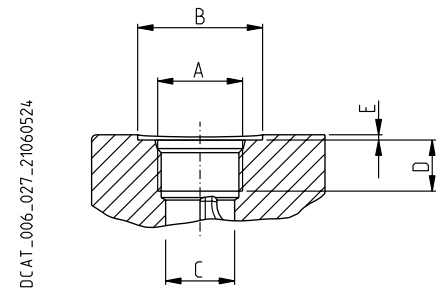
American straight thread UNC-UNF 60° conforms to ANSI B 1.1



| CODE | Nominal size | A | Ø B | | D | E |  |  |
|-----------|--------------|-----------------------|----------------|------------------|--------------------|-------------------|---|---|
| | | | mm (in) | mm (in) | | | | |
| OA | 3/8" | 9/16" - 18 UNF - 2B | 26 (1.0236) | 13 (0.5118) | 15 (0.5906) | 1 (0.03934) | 15 ⁺¹ (133 ÷ 142) | 25 ⁺¹ (221 ÷ 230) |
| | | | | | | 2 (#) (0.0787) | 15 ⁺¹ (#) (133 ÷ 142) | — |
| OB | 1/2" | 3/4" - 16 UNF - 2B | 32 (1.2598) | 17,5 (0.690) | 15 (0.5906) | — | 20 ⁺¹ (177 ÷ 186) | 45 ^{+2,5} (398 ÷ 420) |
| OC | 5/8" | 7/8" - 14 UNF - 2B | 35 (1.3780) | 20,5 (0.8071) | 15 (◆) (0.5906) | 0,5 (0.0197) | 30 ^{+2,5} (266 ÷ 288) | 70 ⁺⁵ (620 ÷ 664) |
| | | | | | 17 (0.6693) | | | |
| OD | 3/4" | 1 1/16" - 12 UNF - 2B | 42 (1.6535) | 24,8 (0.9764) | 20 (0.7874) | 0,5 (0.0197) | 40 ^{+2,5} (354 ÷ 376) | 120 ⁺¹⁰ (1062 ÷ 1151) |
| OF | 1" | 1 5/16" - 12 UNF - 2B | 49 (1.9291) | 30,5 (1.2008) | 20 (0.7874) | 0,5 (0.0197) | 60 ⁺⁵ (531 ÷ 575) | 170 ⁺¹⁰ (1505 ÷ 1593) |
| OG | 1" 1/4 | 1 5/8" - 12 UNF - 2B | 58 (2.2835) | 39,1 (1.5394) | 20 (0.7874) | 0,5 (0.0197) | 70 ⁺⁵ (620 ÷ 664) | 200 ⁺¹⁵ (1770 ÷ 1858) |
| OH | 1" 1/2 | 1 7/8" - 12 UNF - 2B | 65 (2.5591) | 45 (1.7717) | 20 (0.7874) | 0,5 (0.0197) | 100 ⁺⁵ (885 ÷ 929) | 270 ⁺¹⁵ (2389 ÷ 2522) |

(#) = Drain port

(◆) For POLARIS 10

01/10.2003

VALVE OPTIONS

PRIORITY VALVE

P1

Costant delivery and internal recirculation of excess flow.

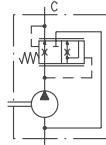

P2

Costant delivery at controlled pressure. Internal recirculation of excess flow and drain valve.

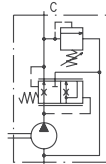

P3

Costant delivery at controlled pressure. Excess flow and drain valve must be connected to tank.

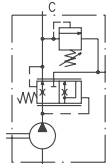

P4

Costant delivery and excess flow can both be used under load.

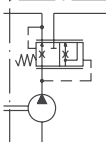

P5T

Costant delivery at controlled pressure with drain valve connected to tank. Excess flow can be used under load.

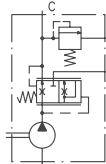

ELECTRIC VALVE

○

UNL...

By-pass valve with anti-cavitation valve.

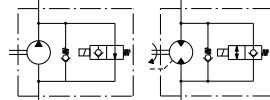

○

PRV...

Proportional relief valve.

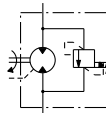

MAX PRESSURE RELIEF VALVE

VPEF...

Fixed setting with external drain.

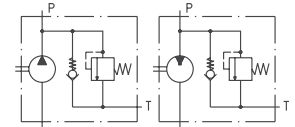

VPIF...

Fixed setting with internal drain.

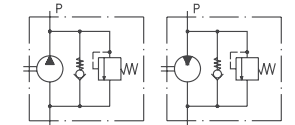

VPER...

Adjustable setting with external drain.

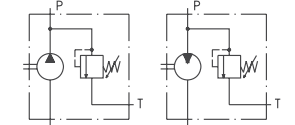

VPIR...

Adjustable setting with internal drain.

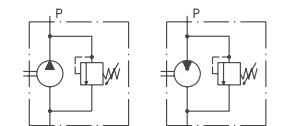

LOAD SENSING VALVE

...

Static.

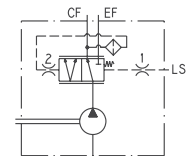

...

Dynamic.

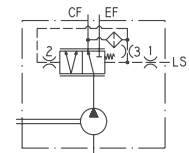

...

Dynamic with relief valve fitted on the main line.

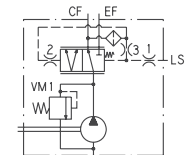

...

Dynamic with relief valve fitted on controlled line.

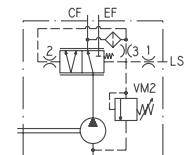

CHECK VALVE

V8

Anti-cavitation valve.

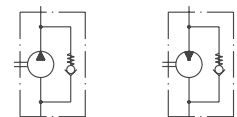

Replaces: 04/10.2020

○ 05/04.2023

Please refer to our built-in valves and fan drive technical catalogues for more information.

NOTES

04/10.2020

HOW TO ORDER POLARIS 10 SINGLE UNITS

| | | | | | | | | | | | | | | | | | | | |
|-----------------|----------|----------|----------|-----------|-----------|----------|----------|--------------|----------|----------|----------|-----------|----------|----------|----------|----------|-----------|----------|-----------|
| 1 | 2 | 3 | 4 | 5 | 6 | 7 | 8 | 9 | 10 | 11 | 12 | 13 | | | | | | | |
| PLP 10-1 | L | 0 | - | 81 | E1 | - | L | BB/BA | - | N | - | EL | - | C | - | L | GA | - | FS |

| 1 | Type | Pump type | Motor type |
|---|--|--------------------|--------------------|
| | 1,07 cm ³ /rev (0.07 in ³ /rev) | PLP 10-1 | PLM 10-1 |
| | 1,60 cm ³ /rev (0.10 in ³ /rev) | PLP 10-1,5 | PLM 10-1,5 |
| | 2,13 cm ³ /rev (0.13 in ³ /rev) | PLP 10-2 | PLM 10-2 |
| | 2,67 cm ³ /rev (0.16 in ³ /rev) | PLP 10-2,5 | PLM 10-2,5 |
| | 3,34 cm ³ /rev (0.20 in ³ /rev) | PLP 10-3,15 | PLM 10-3,15 |
| | 4,27 cm ³ /rev (0.26 in ³ /rev) | PLP 10-4 | PLM 10-4 |
| | 5,34 cm ³ /rev (0.33 in ³ /rev) | PLP 10-5 | PLM 10-5 |
| | 6,20 cm ³ /rev (0.38 in ³ /rev) | PLP 10-5,8 | PLM 10-5,8 |
| | 6,67 cm ³ /rev (0.41 in ³ /rev) | PLP 10-6,3 | PLM 10-6,3 |
| | 8,51 cm ³ /rev (0.52 in ³ /rev) | PLP 10-8 | PLM 10-8 |
| | 10,67 cm ³ /rev (0.65 in ³ /rev) | PLP 10-10 | PLP 10-10 |

| 2 | Rotation | Code |
|---|--------------------------------|----------|
| | Left | S |
| | Right | D |
| | Reversible rear external drain | R |
| | Reversible side external drain | L |
| | Reversible internal drain | B |

| 3 | Versions - Outboard bearing options | Code |
|---|-------------------------------------|----------|
| | Without outboard bearing | 0 |

| 4 | Drive shaft | Code |
|---|---------------------------|-----------|
| | European tapered 1:8 | 81 |
| | European tapered 1:8 | 86 |
| | SAE "AA" spline (9 teeth) | 02 |
| | SAE "AA" straight | 30 |
| | SAE straight | 36 |
| | Straight | 29 |

| 5 | Mounting flange | Code |
|---|-------------------|-----------|
| | European | E1 |
| | European | E7 |
| | European | E8 |
| | German 2 bolt | B1 |
| | German 4 bolt | K2 |
| | SAE "AA" 2 bolt | S0 |
| | SAE "AA" 2-4 bolt | R9 |
| | SAE 2-4 bolt | R8 |
| | SAE 2 bolt | W9 |

| Code | Ports position | 6 |
|----------|----------------|---|
| L | Side | |
| P | Rear | |

| Code | Ports IN/OUT | 7 |
|-----------------------------|--------------|------------------|
| GERMAN FLANGED PORTS | | |
| Side | Rear | Type |
| BB/BA | PLP 10 | 1-1,5-2-2,5-3,15 |
| BA/BB | PLM 10 | 4-5-5,8-6,3-8-10 |

| GAS STRAIGHT THREAD PORTS (BSPP) | | | |
|---|--------------|--------|--------------------|
| Side | Rear | Type | |
| GC/GC | GC/GC | PLP 10 | 1-1,5-2-2,5-3,15-4 |
| | | PLM 10 | |
| GD/GD | GD/GD | PLP 10 | 5-5,8-6,3-8-10 |
| | | PLM 10 | |

| SAE STRAIGHT THREAD PORTS (ODT) | | | |
|--|--------------|--------|--------------------|
| Side | Rear | Type | |
| OB/OA | OB/OA | PLP 10 | 1-1,5-2-2,5-3,15-4 |
| OA/OB | OA/OB | PLM 10 | 5-5,8-6,3 |
| OC/OB | OB/OB | PLP 10 | 8-10 |
| OB/OC | OB/OB | PLM 10 | |

| Code | Seals (a) | 8 |
|----------|-----------------|---|
| N | Buna (standard) | |
| V | Viton | |

| Code | Cover options (b) | 9 |
|-----------|---|---|
| | Cast iron mounting flange and rear cover (standard - no code) | |
| E | Aluminium mounting flange and cast iron rear cover | |
| L | Cast iron mounting flange and aluminium rear cover | |
| EL | Aluminium mounting flange and rear cover | |

| Code | Shaft seal options | 10 |
|-----------|-------------------------------|----|
| D | Standard seal with wiper seal | |
| C1 | High back pressure seal | |

04/10.2020

HOW TO ORDER POLARIS 10 SINGLE UNITS

| 11 | Drain port position - Rev. Rotation L | Code |
|----|--|----------|
| | Side drain with side port position | L |
| | Side drain with bottom port position | * |

| 12 | Drain port | Code |
|--|------------------------------|-------------------|
| IN/OUT GERMAN FLANGED PORTS | | |
| | Type | Side Rear |
| | 1-1,5-2-2,5-3,15 PLP 10 | GA |
| | 4-5-5,8-6,3-8-10 PLM 10 | |
| IN/OUT GAS STRAIGHT THREAD PORTS (BSPP) | | |
| | Type | Side Rear |
| | 1-1,5-2-2,5-3,15 PLP 10 | GA GA |
| | 4-5-5,8-6,3-8-10 PLM 10 | |
| IN/OUT SAE STRAIGHT THREAD PORTS (ODT) | | |
| | Type | Side Rear |
| | 1-1,5-2-2,5-3,15 PLP 10 | 03 03 |
| | 4-5-5,8-6,3-8-10 PLM 10 | |

| 13 | Shaft arrangement | Code |
|----|--------------------------|-----------|
| | Female spline | FS |

- (a) Choose the seals according to the temperature shown on page 5
- (b) Mounting flange material on page 58 ÷ 60
Rear cover material on page 34

02/07.2006

HOW TO ORDER POLARIS 20 SINGLE UNITS

| | | | | | | | | | | | | | | | | | | | |
|-----------------|----------|----------|----------|-----------|-----------|----------|----------|--------------|----------|----------|----------|-----------|----------|----------|----------|----------|-----------|----------|-----------|
| 1 | 2 | 3 | 4 | 5 | 6 | 7 | 8 | 9 | 10 | 11 | 12 | 13 | | | | | | | |
| PLP 20-4 | L | 0 | - | 82 | E2 | - | L | EA/EA | - | N | - | EL | - | C | - | * | GB | - | FS |

| 1 | Type | Pump type | Motor type |
|--|------|--------------------|--------------------|
| 4,95 cm ³ /rev (0.30 in ³ /rev) | | PLP 20-4 | PLM 20-4 |
| 6,61 cm ³ /rev (0.40 in ³ /rev) | | PLP 20-6,3 | PLM 20-6,3 |
| 7,29 cm ³ /rev (0.44 in ³ /rev) | | PLP 20-7,2 | PLM 20-7,2 |
| 8,26 cm ³ /rev 0.50 in ³ /rev) | | PLP 20-8 | PLM 20-8 |
| 9,17 cm ³ /rev 0.56 in ³ /rev) | | PLP 20-9 | PLM 20-9 |
| 10,9 cm ³ /rev (0.66 in ³ /rev) | | PLP 20-10,5 | PLM 20-10,5 |
| 11,23 cm ³ /rev (0.69 in ³ /rev) | | PLP 20-11,2 | PLM 20-11,2 |
| 14,53 cm ³ /rev (0.89 in ³ /rev) | | PLP 20-14 | PLM 20-14 |
| 16,85 cm ³ /rev (1.03 in ³ /rev) | | PLP 20-16 | PLM 20-16 |
| 19,09 cm ³ /rev (1.16 in ³ /rev) | | PLP 20-19 | PLM 20-19 |
| 21,14 cm ³ /rev (1.29 in ³ /rev) | | PLP 20-20 | PLM 20-20 |
| 24,84 cm ³ /rev 1.52 in ³ /rev) | | PLP 20-24,5 | PLM 20-24,5 |
| 26,42 cm ³ /rev (1.61 in ³ /rev) | | PLP 20-25 | PLM 20-25 |
| 28,21 cm ³ /rev (1.72 in ³ /rev) | | PLP 20-27,8 | PLM 20-27,8 |
| 33,03 cm ³ /rev (2.01 in ³ /rev) | | PLP 20-31,5 | PLM 20-31,5 |

| 2 | Rotation | Code |
|--------------------------------|----------|----------|
| Left | | S |
| Right | | D |
| Reversible rear external drain | | R |
| Reversible side external drain | | L |
| Reversible internal drain | | B |

| 3 | Versions - Outboard bearing options | Code |
|--------------------------|-------------------------------------|-----------|
| Without outboard bearing | | 0 |
| With outboard bearing | | W8 |
| With outboard bearing | | 5 |
| With outboard bearing | | 6 |
| With outboard bearing | | 7 |
| With outboard bearing | | 9 |

| 4 | Drive shaft | Code |
|---------------------------|-------------|-----------|
| European tapered 1:8 | | 82 |
| German tapered 1:5 | | 54 |
| German tapered 1:5 | | 55 |
| Straight | | 46 |
| SAE "A" spline (9 teeth) | | 03 |
| SAE spline (10 teeth) | | 01 |
| SAE "A" spline (11 teeth) | | 07 |
| SAE "A" straight | | 31 |

| Code | Drive shaft | 4 |
|-----------|--------------------------------|---|
| 49 | Straight | |
| 50 | Straight | |
| 04 | SAE "B" spline | |
| 32 | SAE "B" straight | |
| 12 | DIN 54 82 | |
| 48 | Straight (only for version 6) | |
| B1 | Straight (for version 5 and 8) | |
| 95 | Tang | |

| Code | Mounting flange | 5 |
|-----------|-----------------|---|
| E2 | European | |
| B2 | German | |
| B4 | German 2 bolt | |
| B5 | German 2 bolt | |
| B6 | German 4 bolt | |
| U2 | German 2 bolt | |
| S1 | SAE "A" 2 bolt | |
| S2 | SAE "A" 2 bolt | |
| S9 | SAE "A" 2 bolt | |
| S5 | SAE "B" 2 bolt | |
| W8 | German | |

| Code | Ports position | 6 |
|----------|----------------|---|
| L | Side | |
| P | Rear | |

| Code | Ports IN/OUT | 7 |
|-------------------------------|--------------|---|
| GERMAN FLANGED PORTS | | |
| Side | Rear | Type |
| BE/BC | PLP 20 | 4-6,3-7,2-8-9-10,5-11,2-14-16-19-20-24,5-25-27,8-31,5 |
| BC/BE | PLM 20 | 27,8-31,5 |
| EUROPEAN FLANGED PORTS | | |
| Side | Rear | Type |
| EA/EA | PLP 20 | 4-6,3-7,2-8-9-10,5-11,2 |
| | PLM 20 | |
| EB/EA | PLP 20 | 14-16-19-20-24,5-25- |
| EA/EB | PLM 20 | 27,8-31,5 |

04/10.2020

HOW TO ORDER POLARIS 20 SINGLE UNITS

| 7 | Ports IN/OUT | Code |
|---|--------------|------|
|---|--------------|------|

| SAE FLANGED PORTS (SSM) | | |
|-------------------------|--------|--------------|
| Type | Side | Rear |
| 4-6,3-7,2-8-9-10,5-11,2 | PLP 20 | MA/MA |
| | PLM 20 | |
| 14-16-19-20 | PLP 20 | MB/MA |
| | PLM 20 | MA/MB |
| 24,5-25-27,8-31,5 | PLP 20 | MC/MB |
| | PLM 20 | MB/MC |

| SAE FLANGED PORTS (SSS) | | |
|-------------------------|--------|--------------|
| Type | Side | Rear |
| 4-6,3-7,2-8-9-10,5-11,2 | PLP 20 | SA/SA |
| | PLM 20 | |
| 14-16-19-20 | PLP 20 | SB/SA |
| | PLM 20 | SA/SB |
| 24,5-25-27,8-31,5 | PLP 20 | SC/SB |
| | PLM 20 | SB/SC |

| GAS STRAIGHT THREAD PORTS (BSPP) | | | |
|----------------------------------|--------|--------------|--------------|
| Type | Side | Rear | |
| 4-6,3-7,2-8-9-10,5-11,2 | PLP 20 | GD/GD | GD/GD |
| | PLM 20 | | |
| 14-16-19-20-24,5-25-27,8-31,5 | PLP 20 | GE/GD | GE/GD |
| | PLM 20 | GD/GE | GD/GE |

| SAE STRAIGHT THREAD PORTS (ODT) | | | |
|---------------------------------|--------|--------------|--------------|
| Type | Side | Rear | |
| 4-6,3-7,2-8-9-10,5-11,2 | PLP 20 | OC/OC | OC/OC |
| | PLM 20 | | |
| 14-16-19-20-24,5-25-27,8-31,5 | PLP 20 | OD/OC | OD/OC |
| | PLM 20 | OC/OD | OC/OD |

| 8 | Seals (a) | Code |
|---|-----------|------|
|---|-----------|------|

| | | |
|---|--|-------------|
| Buna (standard) | | N |
| Viton | | V |
| Hydrogenated buna HNBR seals with Viton-FKM shaft seals | | T-PV |

| 9 | Cover options (b) | Code |
|---|-------------------|------|
|---|-------------------|------|

| | | |
|---|--|-----------|
| Cast iron mounting flange and rear cover (standard - no code) | | |
| Aluminium mounting flange and cast iron rear cover | | E |
| Cast iron mounting flange and aluminium rear cover | | L |
| Aluminium mounting flange and rear cover | | EL |

| 10 | Shaft seal options | Code |
|----|--------------------|------|
|----|--------------------|------|

| | | |
|-------------------------------|--|-----------|
| Standard seal with wiper seal | | D |
| High back pressure seal | | C1 |

| Code | Drain port position - Rev. rotation L | 11 |
|------|---------------------------------------|----|
|------|---------------------------------------|----|

| | | |
|----------|--------------------------------------|--|
| L | Side drain with side port position | |
| * | Side drain with bottom port position | |

| Code | Drain port | 12 |
|------|------------|----|
|------|------------|----|

| IN/OUT GERMAN FLANGED PORTS | | |
|-----------------------------|--------|--------------------------|
| Side | Rear | Type |
| TA | PLP 20 | 4-6,3-7,2-8-9-10,5-11,2- |
| | PLM 20 | 24,5-25-27,8-31,5 |

| IN/OUT EUROPEAN FLANGED PORTS | | |
|-------------------------------|--------|--------------------------|
| Side | Rear | Type |
| GB | PLP 20 | 4-6,3-7,2-8-9-10,5-11,2- |
| | PLM 20 | 24,5-25-27,8-31,5 |

| IN/OUT SAE FLANGED PORTS (SSM) | | |
|--------------------------------|------|------|
| Side | Rear | Type |

| | | |
|-----------|--------|--------------------------|
| GB | PLP 20 | 4-6,3-7,2-8-9-10,5-11,2- |
| | PLM20 | 24,5-25-27,8-31,5 |

| IN/OUT SAE FLANGED PORTS (SSS) | | |
|--------------------------------|------|------|
| Side | Rear | Type |

| | | |
|-----------|--------|--------------------------|
| 03 | PLP 20 | 4-6,3-7,2-8-9-10,5-11,2- |
| | PLM 20 | 24,5-25-27,8-31,5 |

| IN/OUT GAS STRAIGHT THREAD PORTS (BSPP) | | |
|---|------|------|
| Side | Rear | Type |

| | | | |
|-----------|-----------|--------|--------------------------|
| GB | GB | PLP 20 | 4-6,3-7,2-8-9-10,5-11,2- |
| | | PLM 20 | 24,5-25-27,8-31,5 |

| IN/OUT SAE STRAIGHT THREAD PORTS (ODT) | | |
|--|------|------|
| Side | Rear | Type |

| | | | |
|-----------|-----------|--------|-------------------------|
| 03 | 03 | PLP 20 | 4-6,3-7,2-8-9-10,5-11,2 |
| | | PLM 20 | 24,5-25-27,8-31,5 |

| Code | Shaft arrangement | 13 |
|------|-------------------|----|
|------|-------------------|----|

| | | |
|-----------|---------------|--|
| FS | Female spline | |
|-----------|---------------|--|

- (a) Choose the seals according to the temperature shown on page 4.
- (b) Mounting flange material on page 61 ÷ 66
Rear cover material on page 34 ÷ 35

04/10.2020

HOW TO ORDER POLARIS 30 SINGLE UNITS

| | | | | | | | | | | | | | | |
|------------------|----------|----------|----------|-----------|-----------|----------|----------|--------------|----------|----------|----------|----------|----------|-----------|
| 1 | 2 | 3 | 4 | 5 | 6 | 7 | 8 | 9 | 10 | | | | | |
| PLP 30-22 | R | 0 | - | 83 | E3 | - | L | ED/EB | - | N | - | C | - | FS |

| 1 | Type | Pump type | Motor type |
|--|------|------------------|------------------|
| 21,99 cm ³ /rev (1.34 in ³ /rev) | | PLP 30-22 | PLM 30-22 |
| 26,70 cm ³ /rev (1.63 in ³ /rev) | | PLP 30-27 | PLM 30-27 |
| 34,55 cm ³ /rev (2.11 in ³ /rev) | | PLP 30-34 | PLM 30-34 |
| 39,27 cm ³ /rev (2.40 in ³ /rev) | | PLP 30-38 | PLM 30-38 |
| 43,98 cm ³ /rev (2.68 in ³ /rev) | | PLP 30-43 | PLM 30-43 |
| 51,83 cm ³ /rev (3.16 in ³ /rev) | | PLP 30-51 | PLM 30-51 |
| 61,26 cm ³ /rev (3.74 in ³ /rev) | | PLP 30-61 | PLM 30-61 |
| 73,82 cm ³ /rev (4.50 in ³ /rev) | | PLP 30-73 | PLM 30-73 |
| 81,68 cm ³ /rev (4.98 in ³ /rev) | | PLP 30-82 | PLM 30-82 |
| 91,10 cm ³ /rev (5.56 in ³ /rev) | | PLP 30-90 | PLM 30-90 |

| 2 | Rotation | Code |
|--------------------------------|----------|----------|
| Left | | S |
| Right | | D |
| Reversible rear external drain | | R |

| 3 | Versions - Outboard bearing options | Code |
|--------------------------|-------------------------------------|----------|
| Without outboard bearing | | 0 |

| 4 | Drive shaft | Code |
|----------------------|-------------|-----------|
| European tapered 1:8 | | 83 |
| European tapered 1:8 | | 84 |
| German tapered 1:5 | | 56 |
| Straight | | 41 |
| SAE "B" spline | | A8 |
| SAE "BB" spline | | A5 |
| SAE "B" spline | | 04 |
| SAE "BB" spline | | 05 |
| SAE "B" straight | | 32 |
| SAE "BB" straight | | 33 |

| 5 | Mounting flange | Code |
|----------------|-----------------|-----------|
| European | | E3 |
| European | | E4 |
| German | | B3 |
| SAE "B" 2 bolt | | S5 |
| SAE "B" 2 bolt | | U3 |

| 6 | Ports position | Code |
|------|----------------|----------|
| Side | | L |

| Code | Ports IN/OUT | 7 |
|---|--------------|----------------------|
| GERMAN FLANGED PORTS | | |
| Side | | Type |
| BM/BL | PLP 30 | 22-27-34-38-43 |
| BL/BM | PLM 30 | 46-51-61-73-82-90 |
| EUROPEAN FLANGED PORTS | | |
| Side | | Type |
| ED/EB | PLP 30 | 22-27-34-38-43 |
| EB/ED | PLM 30 | 46-51-61 |
| EF/ED | PLP 30 | 73-82-90 |
| ED/EF | PLM 30 | |
| SAE FLANGED PORTS (SSM) | | |
| Side | | Type |
| MB/MA | PLP 30 | 22 |
| MA/MB | PLM 30 | |
| MC/MB | PLP 30 | 27-34 |
| MB/MC | PLM 30 | |
| MD/MC | PLP 30 | 38-43-46-51 |
| MC/MD | PLM 30 | |
| ME/MD | PLP 30 | 61-73-82 |
| MD/ME | PLM 30 | |
| MF/ME | PLP 30 | 90 |
| ME/MF | PLM 30 | |
| SAE FLANGED PORTS (SSS) | | |
| Side | | Type |
| SB/SA | PLP 30 | 22 |
| SA/SB | PLM 30 | |
| SC/SB | PLP 30 | 27-34 |
| SB/SC | PLM 30 | |
| SD/SC | PLP 30 | 38-43-46-51 |
| SC/SB | PLM 30 | |
| SE/SD | PLP 30 | 61-73-82 |
| SD/SE | PLM 30 | |
| SF/SE | PLP 30 | 90 |
| SE/SF | PLM 30 | |
| GAS STRAIGHT THREAD PORTS (BSPP) | | |
| Side | | Type |
| GF/GF | PLP 30 | 22-27-34-38-43-46-51 |
| GG/GF | PLM 30 | |
| GG/GF | PLP 30 | 61-73 |
| GF/GG | PLM 30 | |
| GH/GG | PLP 30 | 82-90 |
| GG/GH | PLM 30 | |

02/07.2006

HOW TO ORDER POLARIS 30 SINGLE UNITS

| 7 | Ports IN/OUT | Code |
|--|---------------------|--|
| SAE STRAIGHT THREAD PORTS (ODT) | | |
| | Type | Rear |
| | 22-27-34 | PLP 30 OF/OD PLM 30 OD/OF |
| | 38-43-46-51 | PLP 30 OG/OF PLM 30 OF/OG |
| | 61-73-82-90 | PLP 30 OH/OG PLM 30 OG/OH |

| 8 | Seals (a) | Code |
|---|------------------|----------|
| | Buna (standard) | N |
| | Viton | V |

| 9 | Shaft seal options | Code |
|---|-------------------------------|-----------|
| | Standard seal with wiper seal | D |
| | High back pressure seal | C1 |

| 10 | Shaft arrangement | Code |
|----|--------------------------|-----------|
| | Female spline | FS |

- (a) Choose the seals according to the temperature shown on page 5.

HOW TO ORDER POLARIS 10 MULTIPLE PUMPS

| | | | | | | | | | | | | | | | | | |
|-----------------------------|---|-----------|-----------|--------------|--------------|--------------|---|----------|----------|----|----------|---|-----------|---|----------|---|-----------|
| 1 | 2 | 3 | 4 | 5 | 6 | 7 | 8 | 9 | 10 | 11 | 12 | | | | | | |
| PLP 10-1 | - | 81 | E1 | - | L | BA/BA | / | | | | | | | | | | |
| Front section | | | | | | | | | | | | | | | | | |
| 10-1 | - | | | L | BA/BA | / | | | | | | | | | | | |
| Intermediate section | | | | | | | | | | | | | | | | | |
| 10-1 | - | | L | **/BA | - | V7 | - | S | 0 | - | N | - | EL | - | C | / | FS |
| Rear section | | | | | | | | | | | | | | | | | |

| 1 | Type | Pump type |
|--|------|--------------------|
| 0,07 in ³ /rev (1,07 cm ³ /rev) | | PLP 10-1 |
| 1,60 cm ³ /rev (0.10 in ³ /rev) | | PLP 10-1,5 |
| 2,13 cm ³ /rev (0.13 in ³ /rev) | | PLP 10-2 |
| 2,67 cm ³ /rev 0.16 in ³ /rev) | | PLP 10-2,5 |
| 3,34 cm ³ /rev (0.20 in ³ /rev) | | PLP 10-3,15 |
| 4,27 cm ³ /rev 0.26 in ³ /rev) | | PLP 10-4 |
| 5,34 cm ³ /rev (0.33 in ³ /rev) | | PLP 10-5 |
| 6,20 cm ³ /rev (0.38 in ³ /rev) | | PLP 10-5,8 |
| 6,67 cm ³ /rev (0.41 in ³ /rev) | | PLP 10-6,3 |
| 8,51 cm ³ /rev (0.52 in ³ /rev) | | PLP 10-8 |
| 10,67 cm ³ /rev (0.65 in ³ /rev) | | PLP 10-10 |

| 2 | Drive shaft | Code |
|---------------------------|-------------|-----------|
| European tapered 1:8 | | 81 |
| European tapered 1:8 | | 86 |
| SAE "AA" spline (9 teeth) | | 02 |
| SAE "AA" straight | | 30 |
| SAE straight | | 36 |
| Straight | | 29 |

| 3 | Mounting flange | Code |
|-------------------|-----------------|-----------|
| European | | E1 |
| European | | E7 |
| European | | E8 |
| German 2 bolts | | B1 |
| German 4 bolts | | K2 |
| SAE "AA" 2 bolt | | S0 |
| SAE "AA" 2-4 bolt | | R9 |
| SAE 2-4 bolt | | R8 |
| SAE 2 bolt | | W9 |

| 4 | Ports position | Code |
|------|----------------|----------|
| Side | | L |

| Code | Ports IN/OUT | 5 |
|---|--------------|-----------------------------------|
| GERMAN FLANGED PORTS | | |
| Side | Type | |
| BB/BA | PLP 10 | 1-1,5-2-2,5-3,15-4-5-5,8-6,3-8-10 |
| GAS STRAIGHT THREAD PORTS (BSPP) | | |
| Side | Type | |
| GC/GC | PLP 10 | 1-1,5-2-2,5-3,15-4 |
| GD/GD | PLP 10 | 5-5,8-6,3-8-10 |
| SAE STRAIGHT THREAD PORTS (ODT) | | |
| Side | Type | |
| OB/OA | PLP 10 | 1-1,5-2-2,5-3,15-4-5-5,8-6,3 |
| OC/OB | PLP 10 | 8-10 |

| Code | Combination type | 6 |
|-----------|------------------|---|
| V6 | Standard | |
| V7 | Common inlet | |

| Code | Rotation | 7 |
|----------|----------|---|
| S | Left | |
| D | Right | |

| Code | Versions - Outboard bearing options | 8 |
|----------|---|---|
| 0 | Without outboard bearing (standard) no code | |

| Code | Seals (a) | 9 |
|----------|-------------------|---|
| N | Buna N (standard) | |
| V | Viton | |

| Code | Cover options (b) | 10 |
|-----------|---|----|
| | Cast iron mounting flange and rear cover (standard - no code) | |
| E | Aluminium mounting flange and cast iron rear cover | |
| L | Cast iron mounting flange and aluminium rear cover | |
| EL | Aluminium mounting flange and rear cover | |

02/07.2006

HOW TO ORDER POLARIS 10 MULTIPLE PUMPS

| 11 | Shaft seal options | Code |
|----|-------------------------------|-----------|
| | Standard seal with wiper seal | D |
| | High back pressure seal | C1 |

| 12 | Shaft arrangement | Code |
|----|-------------------|-----------|
| | Female spline | FS |

- (a) Choose the seals according to the temperature shown on page 5.
- (b) Mounting flange material on page 58 ÷ 60
Rear cover material on page 44

04/10.2020

HOW TO ORDER POLARIS 20 MULTIPLE PUMPS

| | | | | | | | | | | | | | | | | | | | |
|-----------------------------|---|-----------|-----------|---|----------|--------------|---|-----------|----|----------|----------|---|----------|---|-----------|---|----------|---|-----------|
| 1 | 2 | 3 | 4 | 5 | 6 | 7 | 8 | 9 | 10 | 11 | 12 | | | | | | | | |
| PLP 20-4 | - | 82 | E2 | - | L | EA/EA | / | | | | | | | | | | | | |
| Front section | | | | | | | | | | | | | | | | | | | |
| 20-4 | - | | | | L | EA/EA | / | | | | | | | | | | | | |
| Intermediate section | | | | | | | | | | | | | | | | | | | |
| 20-4 | - | | | | L | **/EA | - | S7 | - | S | 0 | - | N | - | EL | - | C | / | FS |
| Rear section | | | | | | | | | | | | | | | | | | | |

| 1 | Type | Pump Type |
|--|------|--------------------|
| 4,95 cm ³ /rev (0.30 in ³ /rev) | | PLP 20-4 |
| 6,61 cm ³ /rev (0.40 in ³ /rev) | | PLP 20-6,3 |
| 7,29 cm ³ /rev (0.44 in ³ /rev) | | PLP 20-7,2 |
| 8,26 cm ³ /rev (0.50 in ³ /rev) | | PLP 20-8 |
| 9,17 cm ³ /rev (0.56 in ³ /rev) | | PLP 20-9 |
| 10,9 cm ³ /rev (0.66 in ³ /rev) | | PLP 20-10,5 |
| 11,23 cm ³ /rev (0.69 in ³ /rev) | | PLP 20-11,2 |
| 14,53 cm ³ /rev (0.89 in ³ /rev) | | PLP 20-14 |
| 16,85 cm ³ /rev (1.03 in ³ /rev) | | PLP 20-16 |
| 19,09 cm ³ /rev (1.16 in ³ /rev) | | PLP 20-19 |
| 21,14 cm ³ /rev (1.29 in ³ /rev) | | PLP 20-20 |
| 24,84 cm ³ /rev (1.52 in ³ /rev) | | PLP 20-24,5 |
| 26,42 cm ³ /rev (1.61 in ³ /rev) | | PLP 20-25 |
| 28,21 cm ³ /rev (1.72 in ³ /rev) | | PLP 20-27,8 |
| 33,03 cm ³ /rev (2.01 in ³ /rev) | | PLP 20-31,5 |

| 2 | Drive shaft | Code |
|-------------------------------|-------------|-----------|
| European tapered 1:8 | | 82 |
| German tapered 1:5 | | 54 |
| German tapered 1:5 | | 55 |
| Straight | | 46 |
| SAE "A" spline (9 teeth) | | 03 |
| SAE spline (10 teeth) | | 01 |
| SAE "A" spline (11 teeth) | | 07 |
| SAE "A" straight | | 31 |
| Straight | | 49 |
| Straight | | 50 |
| SAE "B" spline | | 04 |
| SAE "B" straight | | 32 |
| DIN 54 82 spline | | 12 |
| Straight (only for version 6) | | 48 |
| Straight (only for version 8) | | B1 |
| Tang | | 95 |

| Code | Mounting flange | 3 |
|-----------|-----------------|---|
| E2 | European | |
| B2 | German | |
| B4 | German 2 bolt | |
| B5 | German 2 bolt | |
| B6 | German 4 bolt | |
| U2 | German 2 bolt | |
| S1 | SAE "A" 2 bolt | |
| S2 | SAE "A" 2 bolt | |
| S9 | SAE "A" 2 bolt | |
| S5 | SAE "B" 2 bolt | |
| W8 | German | |

| Code | Ports position | 4 |
|----------|----------------|---|
| L | Side | |

| Code | Ports IN/OUT | 5 |
|--------------------------------|--------------|---|
| GERMAN FLANGED PORTS | | |
| Side | Type | |
| BE/BC | PLP 20 | 4-6,3-7,2-8-9-10,5-11,2 14-16-19-20-24,5-25 27,8-31,5 |
| EUROPEAN FLANGED PORTS | | |
| Side | Type | |
| EA/EA | PLP 20 | 4-6,3-7,2-8-9-10,5-11,2 |
| EB/EA | PLP 20 | 14-16-19-20-24,5-25 27,8-31,5 |
| SAE FLANGED PORTS (SSM) | | |
| Side | Type | |
| MA/MA | PLP 20 | 4-6,3-7,2-8-9-10,5-11,2 |
| MB/MA | PLP 20 | 14-16-19-20 |
| MC/MB | PLP 20 | 24,5-25-27,8-31,5 |
| SAE FLANGED PORTS (SSS) | | |
| Side | Type | |
| SA/SA | PLP 20 | 4-6,3-7,2-8-9-10,5-11,2 |
| SB/SA | PLP 20 | 14-16-19-20 |
| SC/SB | PLP 20 | 24,5-25-27,8-31,5 |

04/10.2020

HOW TO ORDER POLARIS 20 MULTIPLE PUMPS

| 5 | Ports IN/OUT | Code |
|---|--------------|--------------|
| GAS STRAIGHT THREAD PORTS (BSPP) | | |
| Type | | Rear |
| 4-6,3-7,2-8-9-10,5-11,2 | PLP 20 | GD/GD |
| 14-16-19-20-24,5-25-27,8-31,5 | PLP 20 | GE/GD |
| SAE STRAIGHT THREAD PORTS (ODT) | | |
| Type | | Rear |
| 4-6,3-7,2-8-9-10,5-11,2 | PLP 20 | OC/OC |
| 14-16-19-20-24,5 25-27,8-31,5 | PLP 20 | OD/OC |

| 6 | Combination type | Code |
|-----------------|------------------|-----------|
| Standard | | S6 |
| Common inlet | | S7 |
| Separate stages | | Z6 |

| 7 | Rotation | Code |
|-------|----------|----------|
| Left | | S |
| Right | | D |

| 8 | Versions - Outboard bearing options | Code |
|---|-------------------------------------|-----------|
| Without outboard bearing (standard) no code | | 0 |
| With outboard bearing | | W8 |
| With outboard bearing | | 5 |
| With outboard bearing | | 7 |
| With outboard bearing | | 8 |
| With outboard bearing | | 9 |

| Code | Seals (a) | 9 |
|-------------|---|---|
| N | Buna (standard) | |
| V | Viton | |
| T-PV | Hydrogenated buna HNBR seals with Viton-FKM shaft seals | |

| Code | Cover options (b) | 10 |
|-----------|---|----|
| | Cast iron mounting flange and rear cover (standard - no code) | |
| E | Aluminium mounting flange and cast iron rear cover | |
| L | Cast iron mounting flange and aluminium rear cover | |
| EL | Aluminium mounting flange and rear cover | |

| Code | Shaft seal options | 11 |
|-----------|--------------------------------------|----|
| D | Standard shaft seals with wiper seal | |
| C1 | High back pressure seal | |

| Code | Shaft arrangement | 12 |
|-----------|-------------------|----|
| FS | Female spline | |

- (a) Choose the seals according to the temperature shown on page 5.
- (b) Mounting flange material on page 61 ÷ 66
Rear cover material on page 45

04/10.2020

HOW TO ORDER POLARIS 30 MULTIPLE PUMPS

| | | | | | | | | | | | | | | | | |
|-----------------------------|---|-----------|-----------|----------|--------------|--------------|-----------|---|----------|----------|---|----------|---|----------|---|-----------|
| 1 | 2 | 3 | 4 | 5 | 6 | 7 | 8 | 9 | 10 | 11 | | | | | | |
| PLP 30-22 | - | 83 | E3 | - | L | ED/EB | / | | | | | | | | | |
| Front section | | | | | | | | | | | | | | | | |
| 30-22 | - | | | L | ED/EB | / | | | | | | | | | | |
| Intermediate section | | | | | | | | | | | | | | | | |
| 30-22 | - | | | L | ED/EB | - | M6 | - | S | 0 | - | N | - | C | / | FS |
| Rear section | | | | | | | | | | | | | | | | |

| 1 | Type | Pump Type |
|--|------|------------------|
| 21,99 cm ³ /rev (1.34 in ³ /rev) | | PLP 30-22 |
| 26,70 cm ³ /rev (1.63 in ³ /rev) | | PLP 30-27 |
| 34,55 cm ³ /rev (2.11 in ³ /rev) | | PLP 30-34 |
| 39,27 cm ³ /rev (2.40 in ³ /rev) | | PLP 30-38 |
| 43,98 cm ³ /rev (2.68 in ³ /rev) | | PLP 30-43 |
| 51,83 cm ³ /rev (3.16 in ³ /rev) | | PLP 30-51 |
| 61,26 cm ³ /rev (3.74 in ³ /rev) | | PLP 30-61 |
| 73,82 cm ³ /rev (4.50 in ³ /rev) | | PLP 30-73 |
| 81,68 cm ³ /rev (4.98 in ³ /rev) | | PLP 30-82 |
| 91,10 cm ³ /rev (5.56 in ³ /rev) | | PLP 30-90 |

| 2 | Drive shaft | Code |
|----------------------|-------------|-----------|
| European tapered 1:8 | | 83 |
| European tapered 1:8 | | 84 |
| German tapered 1:5 | | 56 |
| Straight | | 41 |
| SAE "B" spline | | A8 |
| SAE "BB" spline | | A5 |
| SAE "B" spline | | 04 |
| SAE "BB" spline | | 05 |
| SAE "B" straight | | 32 |
| SAE "BB" straight | | 33 |

| 3 | Mounting flange | Code |
|----------------|-----------------|-----------|
| European | | E3 |
| European | | E4 |
| German | | B3 |
| SAE "B" 2 bolt | | S5 |
| SAE "B" 2 bolt | | U3 |

| 4 | Ports position | Code |
|------|----------------|----------|
| Side | | L |

| Code | Ports IN/OUT | 5 |
|---|--------------|-------------------------------------|
| GERMAN FLANGED PORTS | | |
| Side | | Type |
| BM/BL | PLP 30 | 22-27-34-38-43 46-51-61-73-82-90 |
| EUROPEAN FLANGED PORTS | | |
| Side | | Type |
| ED/EB | PLP 30 | 22-27-34-38-43 46-51-61 |
| EF/ED | PLP 30 | 73-82-90 |
| SAE FLANGED PORTS (SSM) | | |
| Side | | Type |
| MB/MA | PLP 30 | 22 |
| MC/MB | PLP 30 | 27-34 |
| MD/MC | PLP 30 | 38-43-46-51 |
| ME/MD | PLP 30 | 61-73-82 |
| MF/ME | PLP 30 | 90 |
| SAE FLANGED PORTS (SSS) | | |
| Side | | Type |
| SB/SA | PLP 30 | 22 |
| SC/SB | PLP 30 | 27-34 |
| SD/SC | PLP 30 | 38-43-46-51 |
| SE/SD | PLP 30 | 61-73-82 |
| SF/SE | PLP 30 | 90 |
| GAS STRAIGHT THREAD PORTS (BSPP) | | |
| Side | | Type |
| GF/GF | PLP 30 | 22-27-34-38-43-46-51 |
| GG/GF | PLP 30 | 61-73 |
| GH/GG | PLP 30 | 82-90 |
| SAE STRAIGHT THREAD PORTS (ODT) | | |
| Side | | Type |
| OF/OD | PLP 30 | 22-27-34 |
| OG/OF | PLP 30 | 38-43-46-51 |
| OH/OG | PLP 30 | 61-73-82-90 |

01/10.2003

HOW TO ORDER POLARIS 30 MULTIPLE PUMPS

| 6 | Combination type | Code |
|---|-------------------------|-----------|
| | Standard | M6 |

| 7 | Rotation | Code |
|---|-----------------|----------|
| | Left | S |
| | Right | D |

| 8 | Versions - Outboard bearing options | Code |
|---|---|----------|
| | Without outboard bearing (standard) no code | 0 |

| 9 | Seals (a) | Code |
|---|------------------|----------|
| | Buna (standard) | N |
| | Viton | V |

| 10 | Shaft seal options | Code |
|----|-------------------------------|-----------|
| | Standard seal with wiper seal | D |
| | High back pressure seal | C1 |

| 11 | Shaft arrangement | Code |
|----|--------------------------|-----------|
| | Female spline | FS |

- (a) Choose the seals according to the temperature shown on page 5.

04/10.2020

HOW TO ORDER POLARIS DOUBLE PUMPS DIFFERENT GROUPS

| | | | | | | | | | | | | | | | | | | | | | |
|--|--|---|--|---|--|---|--|---|--|---|--|---|--|---|--|---|--|----|--|----|--|
| 1 | | 2 | | 3 | | 4 | | 5 | | 6 | | 7 | | 8 | | 9 | | 10 | | 11 | |
| PL 30-22 - 83 E3 - L ED/EB / | | | | | | | | | | | | | | | | | | | | | |
| Front section | | | | | | | | | | | | | | | | | | | | | |
| 20-4 - L EA/EA S 0 / FS - L - N | | | | | | | | | | | | | | | | | | | | | |
| Rear section | | | | | | | | | | | | | | | | | | | | | |

| | | | | | | | | | | | | | | | | | | | | | |
|---|--|---|--|---|--|---|--|---|--|---|--|---|--|---|--|---|--|----|--|----|--|
| 1 | | 2 | | 3 | | 4 | | 5 | | 6 | | 7 | | 8 | | 9 | | 10 | | 11 | |
| PLP 30-22 - 83 E3 - L ED/EB - 52 / | | | | | | | | | | | | | | | | | | | | | |
| Front section | | | | | | | | | | | | | | | | | | | | | |
| 10-1 - L BB/BA - S 0 / FS - L - N | | | | | | | | | | | | | | | | | | | | | |
| Rear section | | | | | | | | | | | | | | | | | | | | | |

| | | | | | | | | | | | | | | | | | | | | | |
|---|--|---|--|---|--|---|--|---|--|---|--|---|--|---|--|---|--|----|--|----|--|
| 1 | | 2 | | 3 | | 4 | | 5 | | 6 | | 7 | | 8 | | 9 | | 10 | | 11 | |
| PLP 20-4 - 82 E2 - L EA/EA - 51 / | | | | | | | | | | | | | | | | | | | | | |
| Front section | | | | | | | | | | | | | | | | | | | | | |
| 10-1 - L BB/BA - S 0 / FS - EL - N | | | | | | | | | | | | | | | | | | | | | |
| Rear section | | | | | | | | | | | | | | | | | | | | | |

| | | |
|---|-----------------------------|------------|
| 1 | Type | Pump Type |
| | The same of multiple pumps | PLP |
| 2 | Drive shaft | Code |
| | The same of multiple pumps | ... |
| 3 | Mounting flange | Code |
| | The same of multiple pumps | ... |
| 4 | Ports position | Code |
| | Side | L |
| 5 | Ports IN/OUT | Code |
| | The same of multiple pumps | ../.. |
| 6 | Combination type | Code |
| | PLP30/20 Standard - No code | N6 |
| | PLP30/20 Common inlet | N7 |
| | PLP30/20 Separate stages | Z6 |
| | PLP30/10 Standard - No code | O6 |
| | PLP30/10 Common inlete | Q7 |
| | PLP20/10 Standard - No code | T6 |
| | PLP20/10 Common inlet | T7 |
| | PLP20/10 Separate stages | Z6 |

| | | | |
|------|--|--|----|
| | Code | Rotation | 7 |
| | S | Left | |
| | D | Right | |
| Code | Versions - Outboard bearing options | | 8 |
| | ... | The same of multiple pumps | |
| Code | Shaft arrangement | | 9 |
| | FS | Female spline | |
| Code | Cover options (a) | | 10 |
| | | Cast iron mounting flange and rear cover (standard - no code) | |
| | E | Aluminium mounting flange and cast iron rear cover (only for PLP20/10) | |
| | L | Cast iron mounting flange and aluminium rear cover | |
| | EL | Aluminium mounting flange and rear cover (only for PLP20/10) | |
| Code | Seals | | 11 |
| | | The same of multiple pumps | |

- (a) Mounting flange material:
 PLP 20 on page 61 ÷ 66 - PLP 30 on page 67 ÷ 69
 Rear cover material:
 PLP 10 on page 44 - PLP 20 on page 45

02/07.2006

Our policy is one of continuous improvement in product. Specification of items may, therefore, be changed without notice.

PL 05 T A

Edition: 05/04.2023

Replaces: PL 04 T A



Headquarters:
CASAPPA S.p.A.
Via Balestrieri, 1
43044 Lemignano di Collecchio
Parma (Italy)
Tel. (+39) 0521 30 41 11
Fax (+39) 0521 80 46 00
E-mail: info@casappa.com
www.casappa.com

