

# HYDRAULIC MOTORS HP

## APPLICATION

- » Conveyors
- » Feeding mechanism of robots and manipulators
- » Metal working machines
- » Textile machines
- » Agricultural machines
- » Food industries
- » Grass cutting machinery etc.

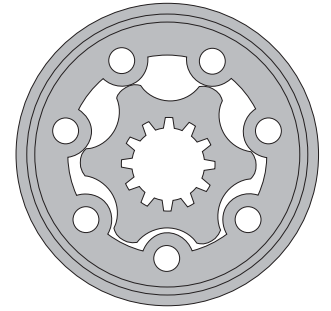

## CONTENTS

Specification data .....	54÷55
Dimensions and mounting .....	56÷57
Shaft versions .....	58÷59
Permissible shaft loads.....	60
Permissible shaft seal pressure .....	60
Order code .....	61

## OPTIONS

- » Model - Spool valve, gerotor
- » Flange mount
- » Side ports
- » Shafts - straight, splined and tapered
- » SAE and manifold ports
- » Speed sensing
- » Other special features

## GENERAL

<b>Max. Displacement,</b> in <sup>3</sup> /rev [cm <sup>3</sup> /rev]	24.16 [396]
<b>Max. Speed,</b> [RPM]	1408
<b>Max. Torque,</b> lb-in [daNm]	cont. 3665 [41,4] int. 4520 [51,1]
<b>Max. Output,</b> HP [kW]	16.1 [12]
<b>Max. Pressure Drop,</b> PSI [bar]	cont. 1815 [125] int. 2540 [175]
<b>Max. Oil Flow,</b> GPM [lpm]	19.8 [75]
<b>Min. Speed,</b> [RPM]	10
<b>Pressure fluid</b>	Mineral based- HLP(DIN 51524) or HM(ISO 6743/4)
<b>Temperature range,</b> °F [°C]	-40÷284 [-40÷140]
<b>Optimal Viscosity range, SUS [mm<sup>2</sup>/s]</b>	98÷347 [20÷75]
<b>Filtration</b>	ISO code 20/16 (Min. recommended fluid filtration of 25 microns)

### Oil flow in drain line

Pressure drop PSI [bar]	Viscosity SUS [mm <sup>2</sup> /s]	Oil flow in drain line GPM [lpm]
1450 [100]	98 [20]	.660 [2,5]
	164 [35]	.476 [1,8]
2030 [140]	98 [20]	.925 [3,5]
	164 [35]	.740 [2,8]

### Pressure Losses

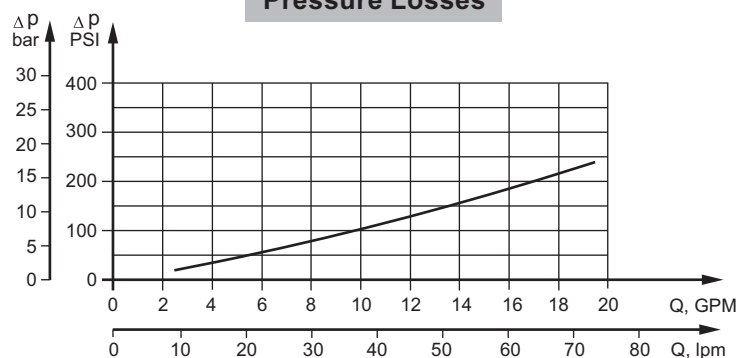

## SPECIFICATION DATA

Type		HP 25	HP 32	HP 40	HP 50	HP 80	HP 100
<b>Displacement, in<sup>3</sup>/rev [cm<sup>3</sup>/rev]</b>		1.73 [28,4]	2.11 [34,5]	2.47 [40,5]	3.02 [49,5]	4.83 [79,2]	6.04 [99,0]
<b>Max. Speed, [RPM]</b>	Cont.	1055	1160	900	909	758	606
	Int.*	1600	1300	1110	1111	947	758
<b>Max. Torque lb-in [daNm]</b>	Cont.	290 [3,3]	460 [5,2]	575 [6,5]	717 [8,1]	1141 [12,9]	1434 [16,2]
	Int.*	400 [4,5]	620 [7,0]	795 [9,0]	990 [11,2]	1585 [17,9]	1974 [22,3]
	Peak**	610 [6,9]	780 [8,8]	975 [11]	1210 [13,7]	1930 [21,8]	2420 [27,3]
<b>Max. Output HP [kW]</b>	Cont.	4.60 [3,4]	7.5 [5,6]	7.5 [5,6]	11.3 [8,4]	11.3 [8,4]	11.3 [8,4]
	Int.*	8.2 [6,1]	11.3 [8,4]	11.5 [8,6]	14.1 [10,5]	16 [12]	16 [12]
<b>Max. Pressure Drop PSI [bar]</b>	Cont.	1450 [100]	1815 [125]	1815 [125]	1815 [125]	1815 [125]	1815 [125]
	Int.*	2030 [140]	2465 [170]	2540 [175]	2540 [175]	2540 [175]	2540 [175]
	Peak**	3260 [225]	3260 [225]	3260 [225]	3260 [225]	3260 [225]	3260 [225]
<b>Max. Oil Flow GPM [lpm]</b>	Cont.	8 [30]	10.5 [40]	10.5 [40]	11.9 [45]	15.9 [60]	15.9 [60]
	Int.*	10.5 [40]	11.9 [45]	11.9 [45]	14.5 [55]	19.8 [75]	19.8 [75]
<b>Max. Inlet Pressure PSI [bar]</b>	Cont.	2030 [140]	2030 [140]	2030 [140]	2030 [140]	2030 [140]	2030 [140]
	Int.*	2540 [175]	2540 [175]	2540 [175]	2540 [175]	2540 [175]	2540 [175]
	Peak**	3260 [225]	3260 [225]	3260 [225]	3260 [225]	3260 [225]	3260 [225]
<b>Max. Return Pressure with Drain Line PSI [bar]</b>	Cont.	2030 [140]	2030 [140]	2030 [140]	2030 [140]	2030 [140]	2030 [140]
	Int.*	2540 [175]	2540 [175]	2540 [175]	2540 [175]	2540 [175]	2540 [175]
	Peak**	3260 [225]	3260 [225]	3260 [225]	3260 [225]	3260 [225]	3260 [225]
<b>Max. Starting Pressure with Unloaded Shaft, PSI [bar]</b>		145 [10]	145 [10]	145 [10]	145 [10]	145 [10]	145 [10]
<b>Min. Starting Torque lb-in [daNm]</b>	At max.press. drop Cont.	265 [3,0]	425 [4,8]	566 [6,4]	655 [7,4]	1045 [11,8]	1300 [14,7]
	At max.press. drop Int.*	362 [4,1]	565 [6,4]	725 [8,2]	900 [10,2]	1440 [16,3]	1800 [20,3]
<b>Min. Speed***, [RPM]</b>		20	15	10	10	10	10
<b>Weight, lb [kg]</b>	HP	11.5 [5,2]	11.5 [5,2]	11.5 [5,2]	11.7 [5,3]	11.9 [5,4]	12.3 [5,6]
	HPQ	10.6 [4,8]	10.6 [4,8]	10.6 [4,8]	10.8 [4,9]	11.25 [5,1]	11.69 [5,3]

\* Intermittent operation: the permissible values may occur for max. 10% of every minute.

\*\* Peak load: the permissible values may occur for max. 1% of every minute.

\*\*\* For speeds lower than given, consult factory or your regional manager.

1. Intermittent speed and intermittent pressure drop must not occur simultaneously.
2. Recommended filtration is per ISO cleanliness code 20/16. A nominal filtration of 25 micron or better.
3. Recommend using a premium quality, anti-wear type mineral based hydraulic oil HLP(DIN51524) or HM (ISO 6743/4).  
If using synthetic fluids consult the factory for alternative seal materials.
4. Recommended minimum oil viscosity 70 SUS [13 mm<sup>2</sup>/s] at 122°F [50°C].
5. Recommended maximum system operating temperature is 180°F [82°C].
6. To assure optimum motor life fill with fluid prior to loading and run at moderate load and speed for 10-15 minutes.

## SPECIFICATION DATA (continued)

Type		HP 125	HP 160	HP 200	HP 250	HP 315	HP 400
<b>Displacement, in<sup>3</sup>/rev [cm<sup>3</sup>/rev]</b>		7.55 [123,8]	9.66 [158,4]	12.1 [198]	15.1 [247,5]	19.3 [316,8]	24.16 [396]
<b>Max. Speed, [RPM]</b>	Cont.	485	379	303	242	189	152
	Int.*	606	473	379	303	237	189
<b>Max. Torque lb-in [daNm]</b>	Cont.	1790 [20,2]	2105 [23,8]	2400 [27,1]	2860 [32,3]	3290 [37,2]	3665 [41,4]
	Int.*	2470 [27,9]	2805 [31,7]	3390 [38,3]	3675 [41,5]	4340 [49,0]	4520 [51,1]
	Peak**	3025 [34,2]	3870 [43,7]	4830 [54,6]	4830 [54,6]	5500 [62,1]	5585 [63,1]
<b>Max. Output HP [kW]</b>	Cont.	11.3 [8,4]	10.3 [7,7]	9.5 [7,1]	9 [6,7]	8.2 [6,1]	7.2 [5,4]
	Int.*	16 [12]	16 [12]	16 [12]	14.3 [10,7]	13.1 [9,8]	11 [8,2]
<b>Max. Pressure Drop PSI [bar]</b>	Cont.	1815 [125]	1670 [115]	1520 [105]	1450 [100]	1305 [90]	1160 [80]
	Int.*	2540 [175]	2250 [155]	2175 [150]	1885 [130]	1740 [120]	1450 [100]
	Peak**	3260 [225]	3260 [225]	3260 [225]	2610 [180]	2320 [160]	1885 [130]
<b>Max. Oil Flow GPM [lpm]</b>	Cont.	15.9 [60]	15.9 [60]	15.9 [60]	15.9 [60]	15.9 [60]	15.9 [60]
	Int.*	19.8 [75]	19.8 [75]	19.8 [75]	19.8 [75]	19.8 [75]	19.8 [75]
<b>Max. Inlet Pressure PSI [bar]</b>	Cont.	2030 [140]	2030 [140]	2030 [140]	2030 [140]	2030 [140]	2030 [140]
	Int.*	2540 [175]	2540 [175]	2540 [175]	2540 [175]	2540 [175]	2540 [175]
	Peak**	3260 [225]	3260 [225]	3260 [225]	3260 [225]	3260 [225]	3260 [225]
<b>Max. Return Pressure with Drain Line PSI [bar]</b>	Cont.	2030 [140]	2030 [140]	2030 [140]	2030 [140]	2030 [140]	2030 [140]
	Int.*	2540 [175]	2540 [175]	2540 [175]	2540 [175]	2540 [175]	2540 [175]
	Peak**	3260 [225]	3260 [225]	3260 [225]	3260 [225]	3260 [225]	3260 [225]
<b>Max. Starting Pressure with Unloaded Shaft, PSI [bar]</b>		145 [10]	145 [10]	100 [7]	100 [7]	100 [7]	100 [7]
<b>Min. Starting Torque lb-in [daNm]</b>	At max.press. drop Cont.	1630 [18,4]	1910 [21,6]	2190 [24,7]	2600 [29,4]	3000 [33,9]	3330 [37,6]
	At max.press. drop Int.*	2250 [25,1]	2550 [28,8]	3090 [34,9]	3345 [37,8]	3950 [44,6]	4115 [46,5]
<b>Min. Speed***, [RPM]</b>		10	10	10	10	10	10
<b>Weight, lb [kg]</b>	HP	12.6 [5,7]	13.0 [5,9]	13.4 [6,1]	13.9 [6,3]	14.6 [6,6]	15.7 [7,1]
	HPQ	11.91 [5,4]	12.35 [5,6]	12.79 [5,8]	13.23 [6,0]	13.89 [6,3]	14.8 [6,7]

\* Intermittent operation: the permissible values may occur for max. 10% of every minute.

\*\* Peak load: the permissible values may occur for max. 1% of every minute.

\*\*\* For speeds lower than given, consult factory or your regional manager.

1. Intermittent speed and intermittent pressure drop must not occur simultaneously.
2. Recommended filtration is per ISO cleanliness code 20/16. A nominal filtration of 25 micron or better.
3. Recommend using a premium quality, anti-wear type mineral based hydraulic oil HLP(DIN51524) or HM (ISO 6743/4).  
If using synthetic fluids consult the factory for alternative seal materials.
4. Recommended minimum oil viscosity 70 SUS [13 mm<sup>2</sup>/s] at 122°F [50°C].
5. Recommended maximum system operating temperature is 180°F [82°C].
6. To assure optimum motor life fill with fluid prior to loading and run at moderate load and speed for 10-15 minutes.

**DIMENSIONS AND MOUNTING DATA FOR HP**

**HPQ**

**HP**

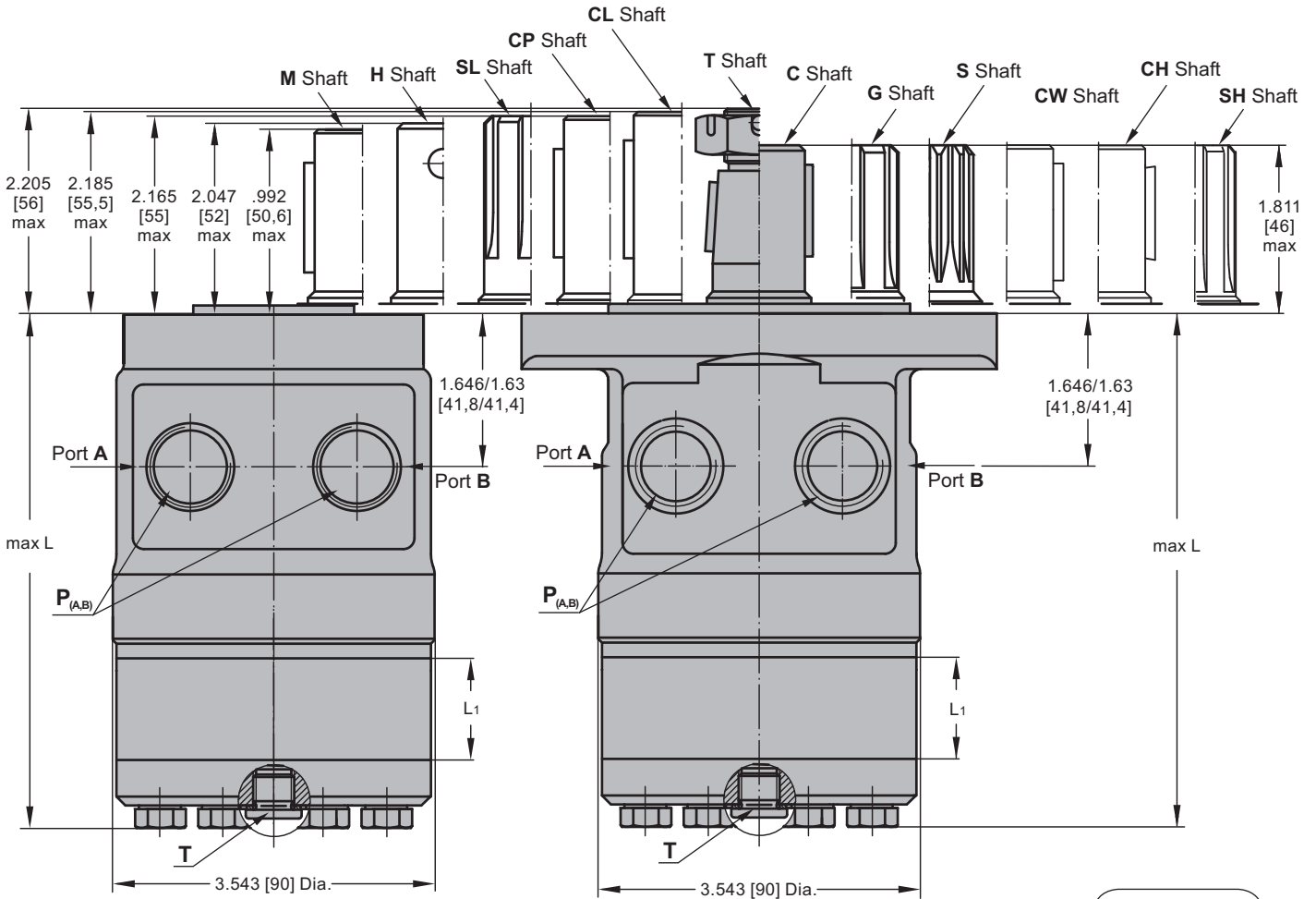

Shaft Dim.  
See Page 58 and 59

Flange Dim.  
See Page 57

Port Dim.  
See Page 57

Type	L <sub>max</sub> , in [mm]	L <sub>1</sub> , in [mm]
HP(Q) 25	4.69 [119,0]	.21 [5,20]
HP(Q) 32	4.72 [120,0]	.25 [6,30]
HP(Q) 40	4.76 [121,0]	.29 [7,40]
HP(Q) 50	4.74 [120,5]	.26 [6,67]
HP(Q) 80	4.90 [124,5]	.42 [10,67]
HP(Q) 100	5.00 [127,0]	.52 [13,33]
HP(Q) 125	5.14 [130,5]	.66 [16,67]
HP(Q) 160	5.32 [135,0]	.84 [21,33]
HP(Q) 200	5.53 [140,5]	1.05 [26,67]
HP(Q) 250	5.79 [147,0]	1.31 [33,33]
HP(Q) 315	6.16 [156,5]	1.68 [42,67]
HP(Q) 400	6.57 [167,0]	2.10 [53,33]

**Standard Rotation**  
Viewed from Shaft End  
Port A Pressurized - CW  
Port B Pressurized - CCW

**Reverse Rotation**  
Viewed from Shaft End  
Port A Pressurized - CCW  
Port B Pressurized - CW



**MOUNTING**

**SAE A Flange**

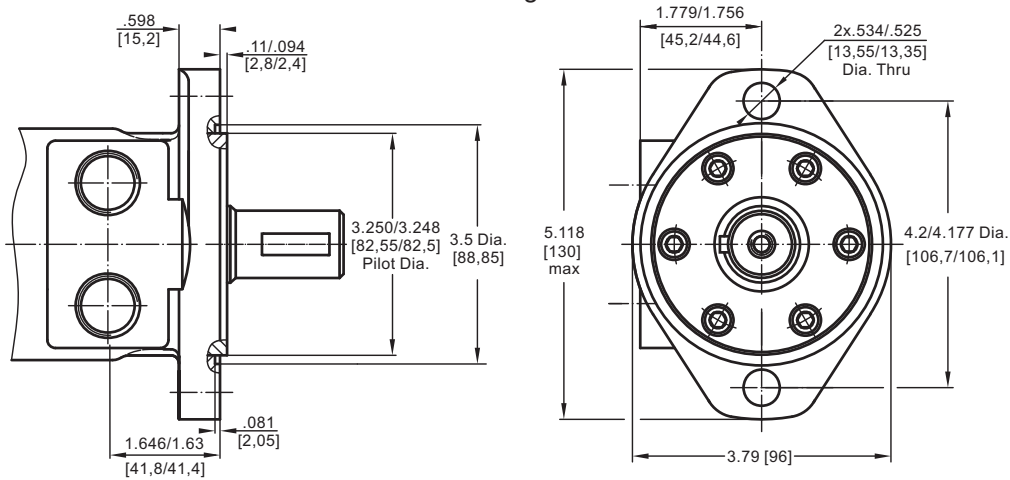

**Q - Square Flange**

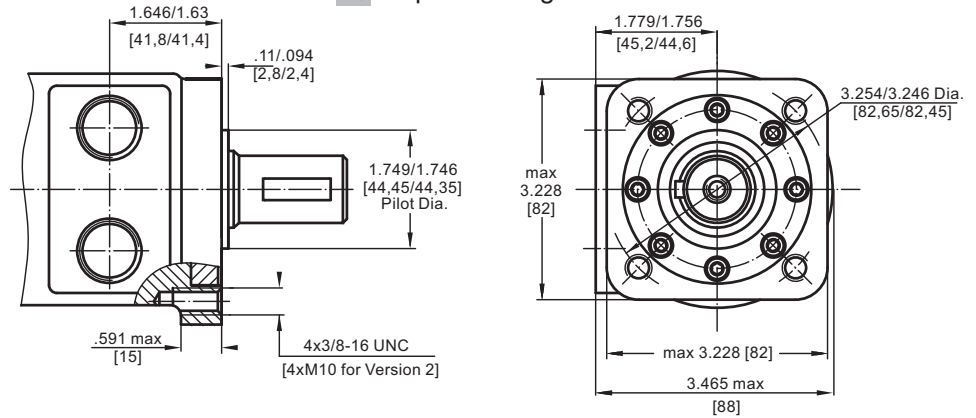

**PORTS**

**Side Ports**

Version **1**, **3**

Version **4**

Version **2**, **5**

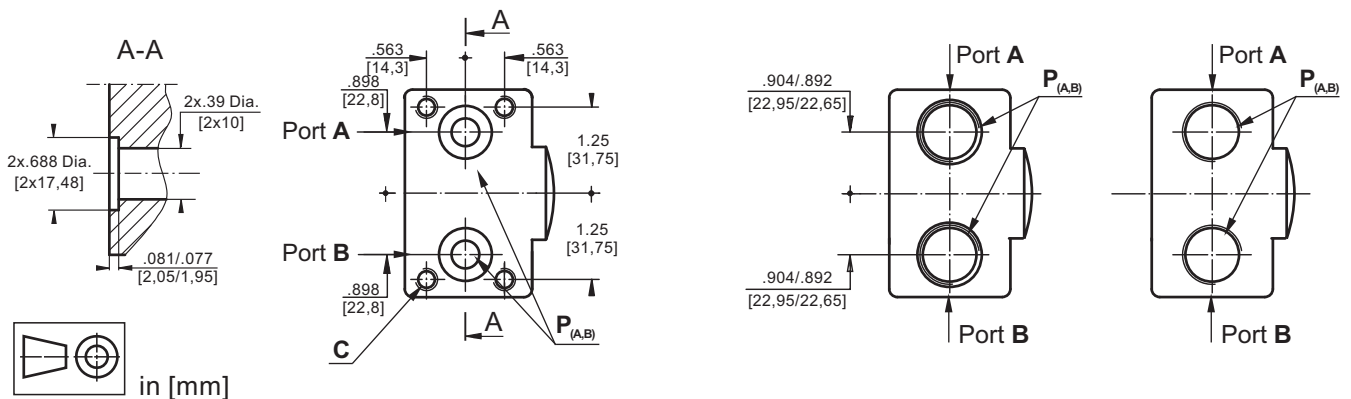

**Standard Rotation**  
Viewed from Shaft End  
Port A Pressurized - CW  
Port B Pressurized - CCW

**Reverse Rotation**  
Viewed from Shaft End  
Port A Pressurized - CCW  
Port B Pressurized - CW

	<b>Versions</b>				
	<b>1</b>	<b>2</b>	<b>3</b>	<b>4</b>	<b>5</b>
<b>C</b>	4x 5/16-18UNC	-	4x M8	-	-
<b>P<sub>(A,B)</sub></b>	2x.39 Dia. [2x10]	2xG1/2	2x.39 Dia. [2x10]	2x 7/8-14UNF	2x 1/2-14NPTF
<b>T</b>	7/16 -20UNF	G1/4	7/16 -20UNF	7/16 -20UNF	7/16 -20UNF

**SHAFT EXTENSIONS FOR HP AND HR MOTORS**

**C**

1" [25,4] straight, Woodruff key 1/4"x1" SAE J502  
Max. Torque 3009 lb-in [34 daNm]

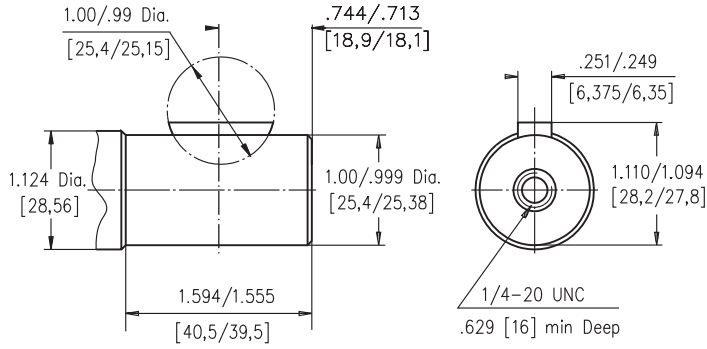

**H**

1" [25,4] straight, w/ .315 [8] Crosshole  
Max. Torque 3009 lb-in [34 daNm]

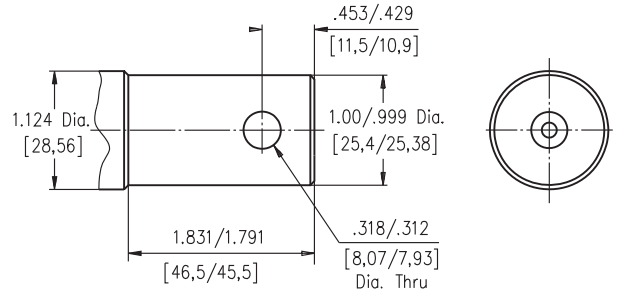

**G**

1" [25,4], SAE 6B Splined  
Max. Torque 3540 lb-in [40 daNm]

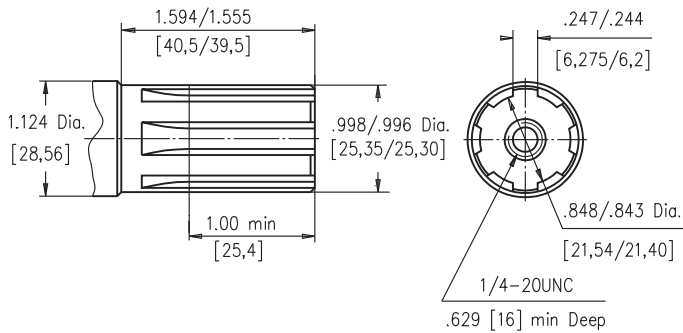

**S**

13T Splined, 7/8" [22,2], ANS B 92.1-1976  
Max. Torque 3200 lb-in [36 daNm]

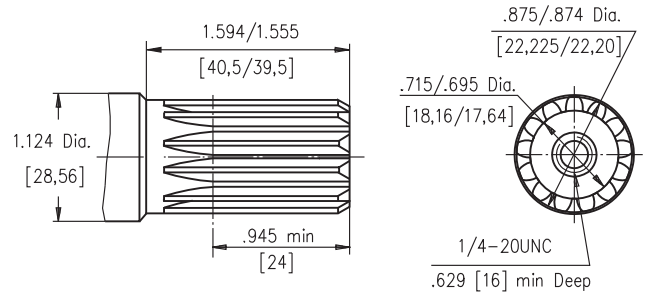

**T**

1" [25,4], SAE J501 Tapered  
Parallel key 3/16"x3/16"x3/4"  
Max. Torque 3540 lb-in [40 daNm]

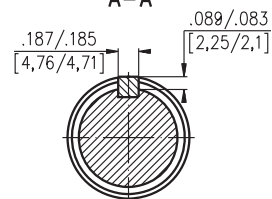
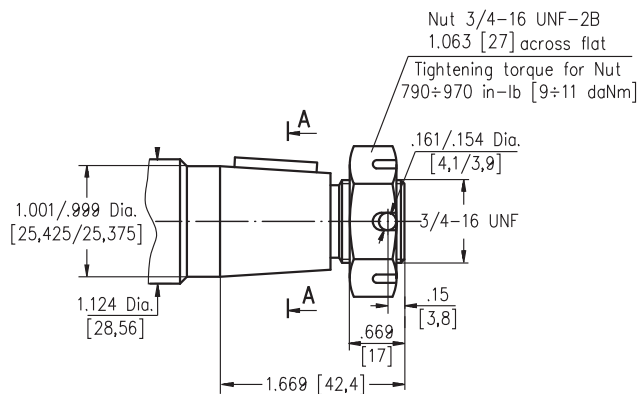

1.5 Taper per Foot  
[cone 1:8]



Requirement max. Torque must not be exceeded.

**SHAFT EXTENSIONS FOR HP AND HR MOTORS**

**M**

ø25 straight, Parallel key A8x7x32 DIN 6885  
Max. Torque 3009 lb-in [34 daNm]

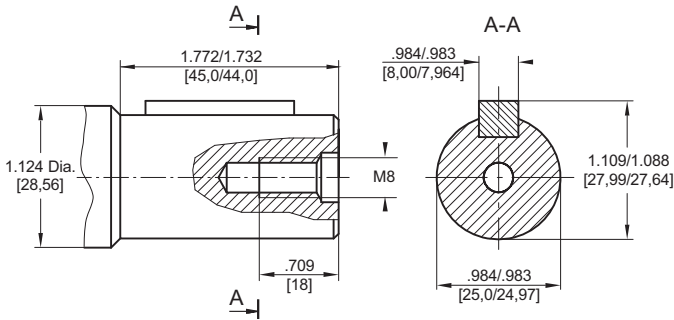

**CP**

ø25 straight, Parallel key A8x7x32 DIN 6885  
Max. Torque 3009 lb-in [34 daNm]

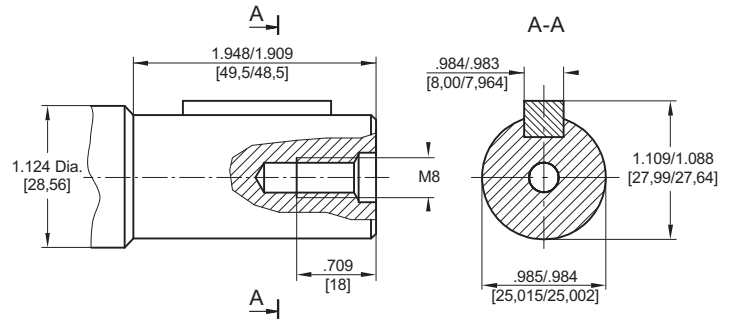

**CL**

1" [25,4] straight, Parallel key 1/4"x1/4"x1/4" BS46  
Max. Torque 3009 lb-in [34 daNm]

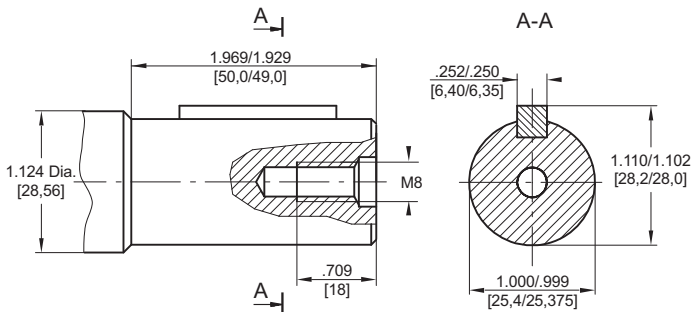

**CW**

ø25 straight, Parallel key A8x7x32 DIN 6885  
Max. Torque 3009 lb-in [34 daNm]

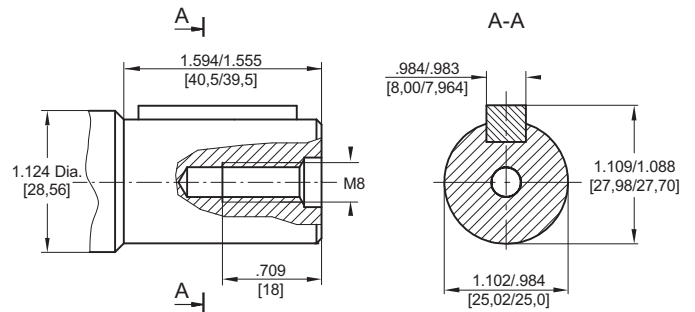

**CH**

ø25 straight, Woodruff key 1/4"x1" SAE J502  
Max. Torque 3009 lb-in [34 daNm]

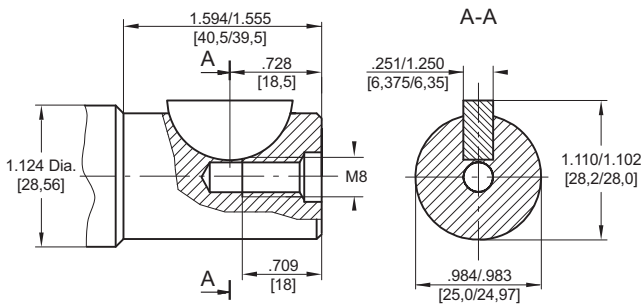

**SH**

1" [25,4], SAE 6B Splined  
Max. Torque 3540 lb-in [40 daNm]

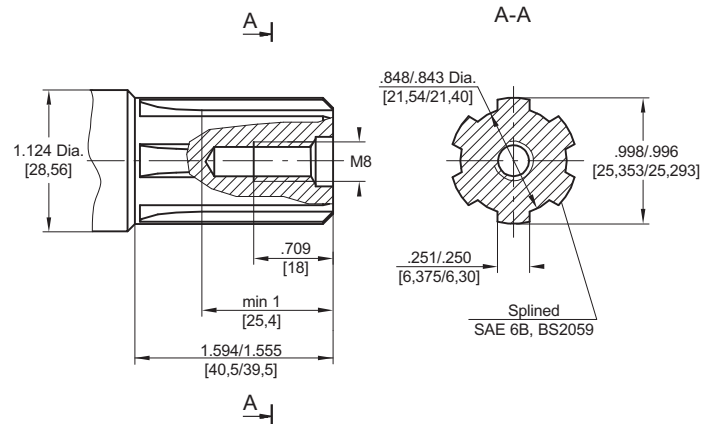

**SL**

1" [25,4], SAE 6B Splined  
Max. Torque 3540 lb-in [40 daNm]

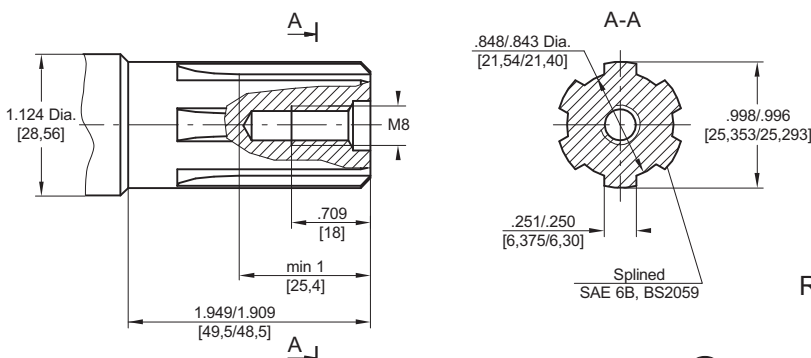

Requirement max. Torque must not be exceeded.

**PERMISSIBLE SHAFT LOADS FOR HP AND HR MOTORS**

The permissible radial shaft load  $P_{rad}$  depends on the speed RPM and distance  $L$  from the point of load to the mounting flange.

$$\text{Radial Shaft Load } P_{rad} = \frac{650}{\text{RPM}} \times \frac{23200}{89+L}, \text{ daN}^*$$

\*  $L$  - in mm.

$$\text{Radial Shaft Load: } P_{rad} = \frac{1460}{\text{RPM}} \times \frac{913}{3.5+L}, \text{ lbs}^*$$

\*  $L$  - in inch

RPM < 200 => max Prad=1460 lbs [650 daN]

RPM ≥ 200;  $L < 2.2$  in. [55 mm]

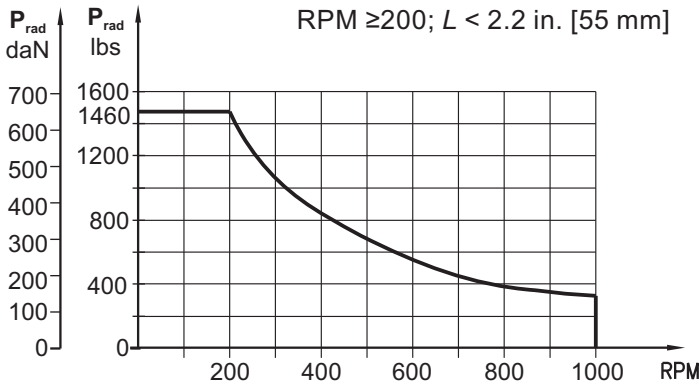

$P_a \text{ max} = 330 \text{ lbs}$   
[150 daN]

$P_a \text{ max} = 440 \text{ lbs}$   
[200 daN]

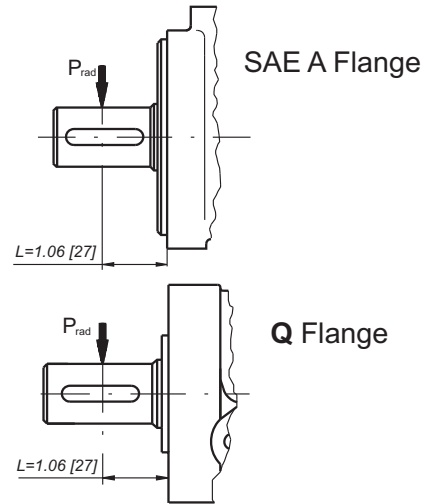

**MAX. PERMISSIBLE SHAFT SEAL PRESSURE FOR HP AND HR MOTORS**

<i>HP...1 and HR...1 motors without drain connection:</i>	<i>HP... and HR... motors with drain connection:</i>	<i>HP...K and HR...K motors with check valves and drain connection:</i>	<i>HP...K1 and HR...K1 motors with check valves and without drain connection:</i>
The shaft seal pressure equals the average of input pressure and return pressure. $P_{seal} = \frac{P_{input} + P_{return}}{2}$	The shaft seal pressure equals the pressure in the drain line.	The shaft seal pressure equals the pressure in the drain line.	The shaft seal pressure never exceeds the pressure in the return line.

**Max. return pressure without drain line or max. pressure in the drain line**

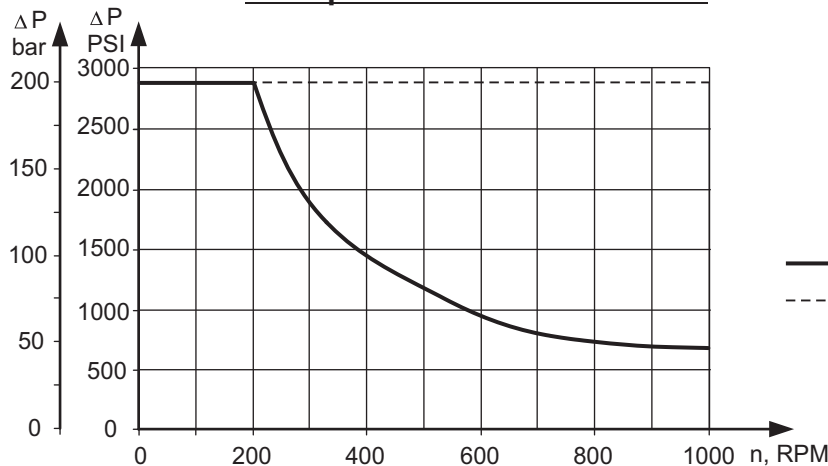

— - continuous operations  
- - - - - intermittent operations



**ORDER CODE**

	1	2	3	4	5	6	7	8	9
<b>HP</b>					<b>U</b>				

**Pos.1 - Mounting Flange**

- omit - SAE A, two holes
- Q** - Square, four bolts

**Pos.2 - Displacement code\***

- 25** - 1.52 in<sup>3</sup>/rev [ 25,0 cm<sup>3</sup>/rev]
- 32** - 1.95 in<sup>3</sup>/rev [ 32,0 cm<sup>3</sup>/rev]
- 40** - 2.44 in<sup>3</sup>/rev [ 40,0 cm<sup>3</sup>/rev]
- 50** - 3.02 in<sup>3</sup>/rev [ 49,5 cm<sup>3</sup>/rev]
- 80** - 4.83 in<sup>3</sup>/rev [ 79,2 cm<sup>3</sup>/rev]
- 100** - 6.04 in<sup>3</sup>/rev [ 99,0 cm<sup>3</sup>/rev]
- 125** - 9.66 in<sup>3</sup>/rev [123,8 cm<sup>3</sup>/rev]
- 160** - 9.74 in<sup>3</sup>/rev [158,4 cm<sup>3</sup>/rev]
- 200** - 12.10 in<sup>3</sup>/rev [198,0 cm<sup>3</sup>/rev]
- 250** - 15.10 in<sup>3</sup>/rev [247,5 cm<sup>3</sup>/rev]
- 315** - 19.30 in<sup>3</sup>/rev [316,8 cm<sup>3</sup>/rev]
- 400** - 24.16 in<sup>3</sup>/rev [396,0 cm<sup>3</sup>/rev]

**Pos.3 - Shaft Extensions\*\***

- C** - 1" [25,4] straight, Woodruff key
- G** - 1" [25,4] SAE 6B Splined
- H** - 1" [25,4] straight, w/.315 [8] Cross-hole
- S** - 7/8" [22,2] 13T Splined
- T** - 1" [25,4] SAE J501 Tapered
- M** - ø25 straight, Parallel key A8x7x32 DIN 6885
- CP** - ø25 straight, Parallel key A8x7x32 DIN 6885
- CL** - 1" [25,4] straight, Parallel key 1/4"x1/4"x1/4" BS46
- CW** - ø25 straight, Parallel key A8x7x32 DIN 6885
- CH** - ø25 straight, Woodruff key 1/4"x1" SAE J502
- SH** - 1" [25,4], SAE 6B Splined
- SL** - 1" [25,4], SAE 6B Splined

**Pos.4 - Port Size/Type** [standard manifold to each]

- 1** - side ports, Manifold [5/16-18 UNC Mounting Threads], 7/16-20 UNF
- 2** - side ports, 2xG1/2, G1/4
- 3** - side ports, Manifold [M8 Mounting Threads], 7/16-20 UNF
- 4** - side ports, 2x7/8-14 UNF, O-ring, 7/16-20 UNF
- 5** - side ports, 2x1/2-14 NPTF, 7/16-20 UNF

**Pos.5 - Shaft Seal Version** [see page 60]

- U** - High pressure shaft seal

**Pos.6 - Check Valves**

- omit - Without check valves
- K** - With check valves

**Pos.7 - Drain Port**

- omit - with drain port
- 1** - without drain port

**Pos.8 - Special Features** [see page 102]

**Pos.9 - Design Series**

- omit - Factory specified

**Notes:**

- \* For the Function Diagrams please look at "M+S Hydraulic" Catalogue for MLHP motors, pages 18÷24.
- \*\* The permissible output torque for shafts must not be exceeded!

The hydraulic motors are mangano-phosphatized as standard.