

Lithium Iron Phosphate Battery

ELECTRICAL CHARACTERISTICS	
Nominal Voltage	12.8 V
Nominal Capacity	200 Ah
Capacity @ 25A	480 min
Internal Resistance (AC)	≤3mΩ
Cycle Life @0.5C 100%DOD	>3000 cycles
Efficiency of Charge @ 0.5C	100%
Efficiency of discharge @ 0.5C	96~ 99% @0.5C
Self Discharge	<3% per Month

MECHANICAL SPECIFICATIONS	
Dimensions (L x W x H /TH)	522 x 240 x 220 / 225mm
Approx. Weight	21.9 kg
Terminal Type	M8
Terminal Torque	80 - 100 in-lbs (9 - 11 N-m)
Case Material	ABS
Enclosure Protection	IP66
Cell Type - Chemistry	LiFePO ₄

CHARGE CHARACTERISTICS	
Recommended Charge Current (0.2C)	50 A
Maximum Charge Current (0.5C)	100 A
Charge Current (14 to 32°F / -10 to 0 °C)	≤0.1 C
Charge Current(-4 to 14°F / -20 to -10°C)	≤0.05 C
Charge Mode with charge current and volt	0.2C to 14.6V, then 14.6V with charge current to 0.02C
Recommended Charge Voltage	14.0 V - 14.6 V
BMS Charge Voltage Cut-Off	15.6 V (3.9 ±0.025vpc)
Reconnect Voltage	15.2 V (3.8 ±0.05 vpc)
Balancing Voltage	14.4 V (3.6 vpc)

DISCHARGE CHARACTERISTICS	
Maximum Continuous Discharge Current	100 A
Peak Discharge Current	120 A (7.5 s ±2.5 s)
BMS Discharge Current Cut-Off	120 A ±15 A (9 ms)
Recommended Low Voltage Disconnect	12 V
BMS Discharge Voltage Cut-Off	16 V (2.0 ±0.08 vpc)
Reconnect Voltage	18.4 V (2.0 ±0.08 vpc)
Short Circuit Protection	200-600 μs

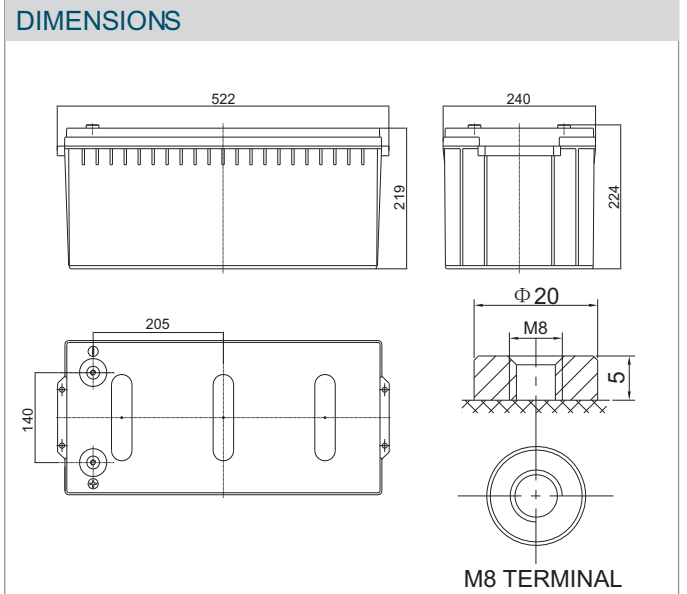
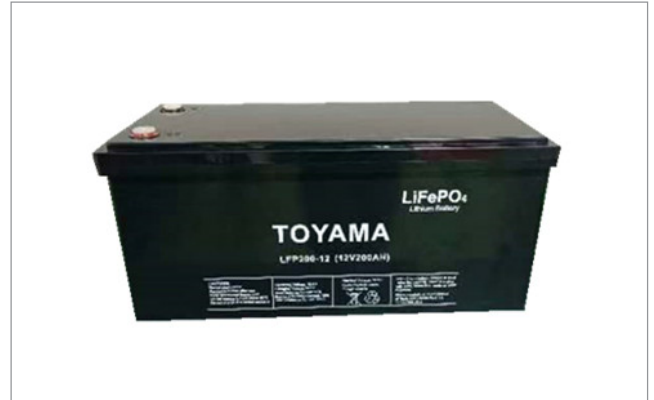

TEMPERATURE	
Discharge Temperature	-4 to 140 °F (-20 to 60 °C)
Charge Temperature*	-4 to 113 °F (-20 to 45 °C)
Storage Temperature	23 to 95 °F (-5 to 35 °C)
BMS High Temperature Cut-Off	167 °F (75 °C)
Reconnect Temperature	149 °F (65 °C)

*Refer to charge currents below 32° F (0° C)

COMPLIANCE	
Certifications	UN38.3 (battery) CE (battery) UL1642 & IEC62133 (cells)
Shipping Classification	UN 3480, CLASS 9

Lithium Iron Phosphate Battery

CELL SPECIFICATIONS

ITEM	SPECIFICATION	
Rated capacity	200	Ah@0.5C
Internal resistance	≤0.6mΩ (50%SOC)	
Normal voltage	3.20	V
Cell dimensions	(33±0.3mm*(200±1)mm*(204±0.5)mm	

CELL DIAGRAMS

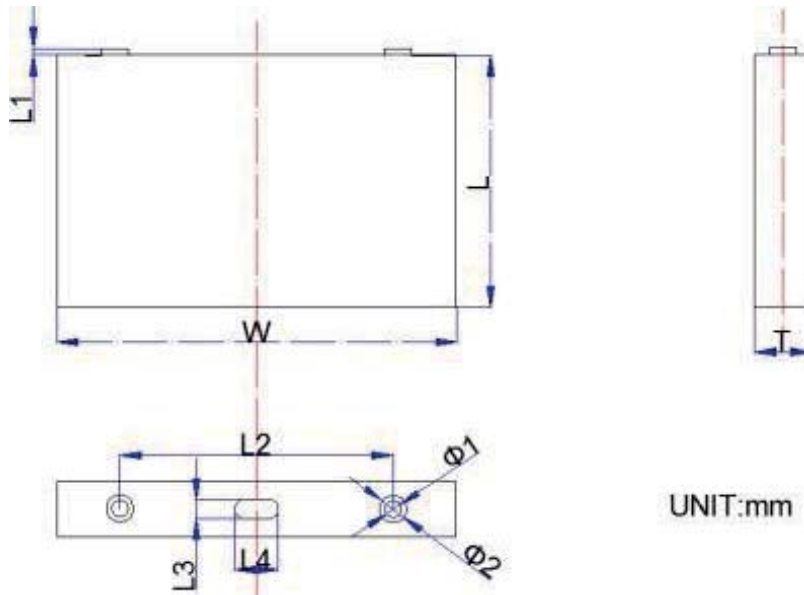

UNIT:mm

No	Name	technical parameters
1	T	33±0.5mm
2	W	200±0.5mm
3	L	204 ±0.5mm
4	L1	5 ±0.5 mm



Lithium Iron Phosphate Battery

Different Rate Discharge Curve (25°C)

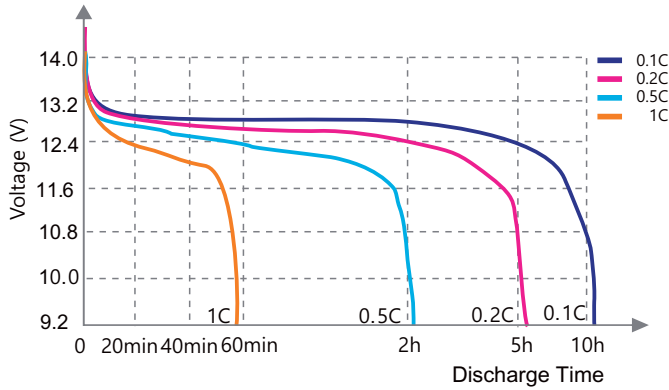

Different Temperature Discharge Curve (40A, 25°C)

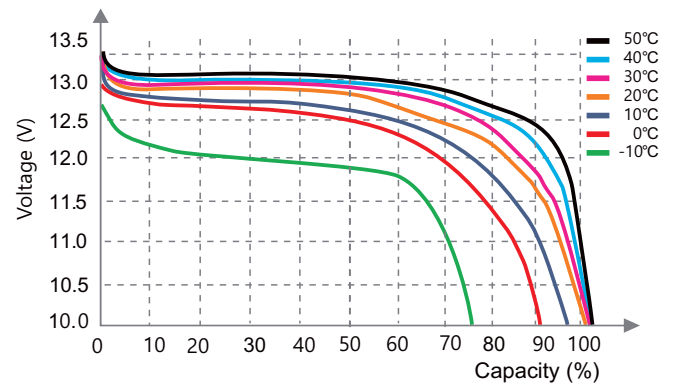

State of Charge Curve (40A, 25°C)

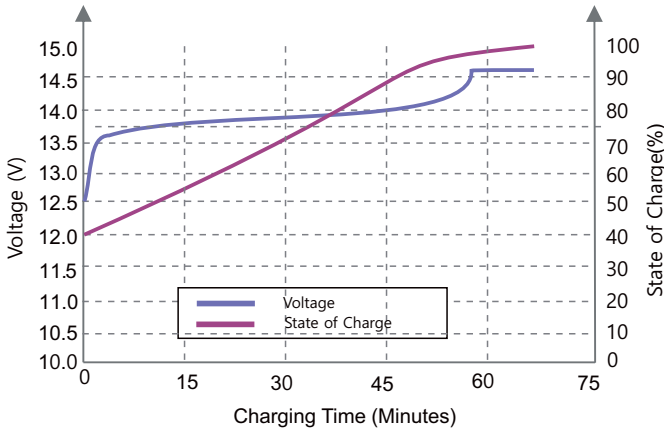

Charging Characteristics (40A, 25°C)

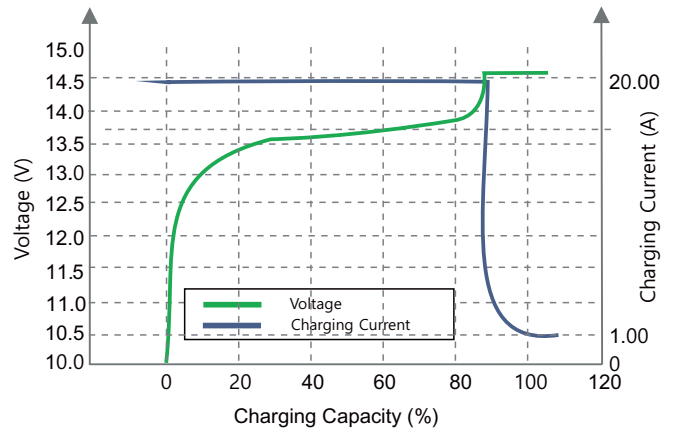

Different DOD Discharge Cycle Life Curve(1C)

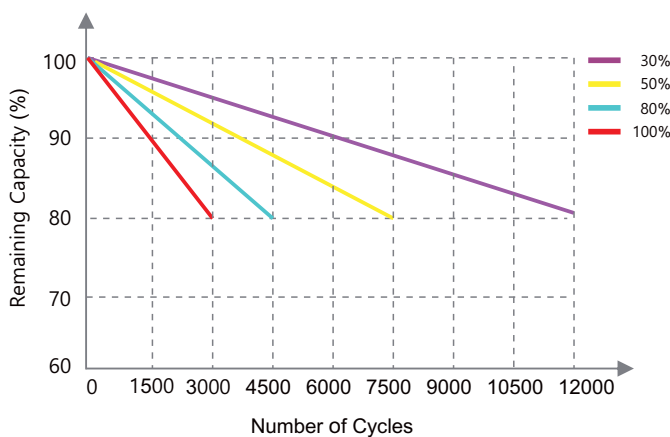

Different Temperature Self Discharge Curve

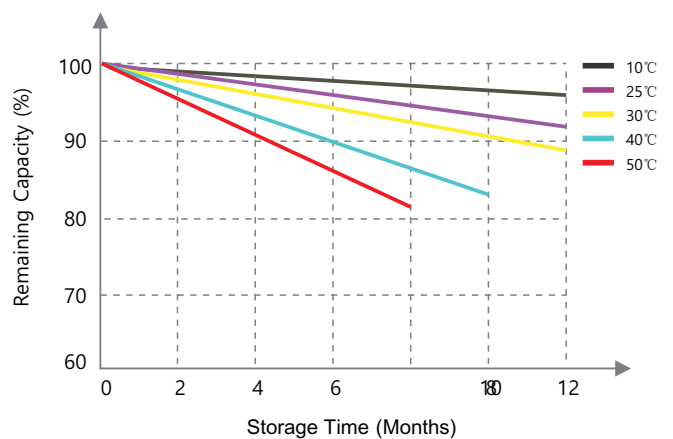

more cycles you can get

RoHS ISO9001 CE IEC