



E49-400T20D User Manual

433MHz DIP Wireless Module



CONTENTS

1. OVERVIEW.....	3
1.1 INTRODUCTION.....	3
1.2 FEATURES.....	3
1.3 APPLICATION.....	3
2. SPECIFICATION AND PARAMETER.....	4
2.1 LIMIT PARAMETER.....	4
2.2 OPERATING PARAMETER.....	4
3. SIZE AND PIN DEFINITION.....	5
4. CONNECT TO MCU.....	6
5. FUNCTION DESCRIPTION.....	7
5.1 MODULE RESET.....	7
5.2 AUX DESCRIPTION.....	7
5.2.1 <i>Wireless receiving indication</i>	7
5.2.2 <i>Wireless transmission indication</i>	7
5.2.3 <i>Reset and exit sleep mode</i>	8
5.3.4 <i>Notes for AUX</i>	8
5.3.5 <i>Fixed-point mode description</i>	8
5.3.6 <i>Broadcast transmission</i>	9
5.3.7 <i>Broadcast address</i>	9
5.3.8 <i>MONITOR ADDRESS</i>	9
6. OPERATING MODE.....	10
6.1 MODE SWITCHING.....	10
6.2 TRANSMISSION MODE (MODE 0)	11
6.3 RSSI MODE (MODE 1)	11
6.4 SETTING MODE (MODE 2)	11
6.5 SLEEP MODE (MODE 3)	12
6.6 FAST COMMUNICATION TEST.....	12
7. COMMAND FORMAT.....	13
7.1 FACTORY DEFAULT PARAMETER.....	13
7.2 READING OPERATING PARAMETER.....	13
7.3 VERSION NUMBER READING.....	13
7.4 PARAMETER SETTING COMMAND.....	14

8. HARDWARE DESIGN	16
9. FAQ	17
9.1 COMMUNICATION RANGE IS TOO SHORT.....	17
9.2 MODULE IS EASY TO DAMAGE.....	17
9.3 BER(BIT ERROR RATE) IS HIGH.....	17
10. WELDING GUIDANCE	18
10.1 REFLOW SOLDERING TEMPERATURE.....	18
10.2 REFLOW SOLDERING CURVE.....	18
11. RELATED MODEL	19
12. ANTENNA GUIDANCE	19
12.1 ANTENNA RECOMMENDATION.....	19
13. BATCH PACKAGING	20
REVISION HISTORY	20
ABOUT US	20

1. Overview

1.1 Introduction

E49-400T20D is an ultra-high cost-effective wireless module developed by Chengdu Ebyte. There are 4 operating modes. Each transmission mode has its own characteristics and can be applied to various application scenarios. E49-400T20D perfectly supports industrial-grade applications, and undergoes rigorous testing at factory to ensure its industrial reliability and batch consistency.

E49-400T20D supports a maximum transmission power of 20dBm. Users can set a lower output power to save power consumption. The module works at 433MHz, with TTL level output, and is compatible with 3.3V.

The module has data encryption function. The data transmitted by the module in the air is random. Through strict encryption and decryption algorithms, the data interception is meaningless, the probability of interference is reduced, and the reliability and transmission efficiency are improved. Besides, it is a low-cost wireless serial transceiver module.

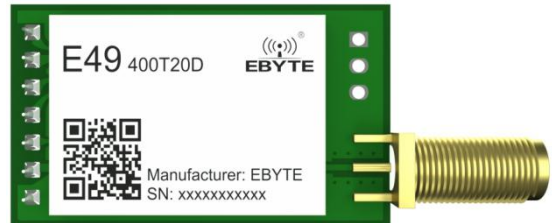

1.2 Features

- The measured communication distance is up to 1km;
- Maximum transmit power is 100mW, software can be adjusted at multiple levels;
- The global license-free ISM 433MHz frequency band;
- Data transmission rate :1.2Kbps~200Kbps;
- Low power consumption mode, suitable for battery application;
- Advanced ultra-narrowed GFSK modulation;
- 2.6V~3.3V power supply;
- Industrial-grade standard design for long-term use of -40 ~ 85°C;
- SMA antenna interface.

1.3 Application

- Wearable devices;
- Smart home and industrial sensors;
- Security system, Positioning system;
- Wireless remote control, unmanned drone;
- Wireless game remote control;
- Health care product;
- Wireless voice, wireless headphones;
- Automobile industry application.

2. Specification and parameter

2.1 Limit parameter

Main parameter	Performance		Remark
	Min.	Max.	
Power supply (V)	0	3.3	Voltage over 5.5V will cause permanent damage to the module
Blocking power (dBm)	-	10	Chances of burn is slim when modules are used in short distance
Operating temperature (°C)	-40	80	

2.2 Operating parameter

Main parameter		Performance			Remark
		Min.	Typ.	Max.	
Operating voltage (V)		2.6	3.3	3.6	
Communication level (V)			3.3		
Operating temperature (°C)		-40	-	80	Industrial design
Operating frequency (MHz)		410	433	510	Support ISM band
Power consumption	TX current (mA)		75		Instant power consumption
	RX current (mA)		12		
	Sleep current (µA)		0.7		Software is shut down
Max Tx power (dBm)		-	-	20.0	
Receiving sensitivity (dBm)		-116	-117	-117	Air data rate is 1.2kbps
Air data rate (bps)		1.2k	2.4k	200k	Controlled via user's programming

Main parameter	Description	Remark
Distance for reference	1000m	Test condition : clear and open area, antenna gain: 5dBi, antenna height: 2.5m, air data rate: 1.2kbps
Sub-packet	54 Byte	The maximum capacity of a single package is automatically packed after exceeding.
Buffer	500 Byte	
Modulation	GFSK	
Communication interface	UART	
Package	DIP	
Connector	2.54mm pin header	
Size	36*21mm	
Antenna	SMA	50 ohm impedance

3. Size and pin definition

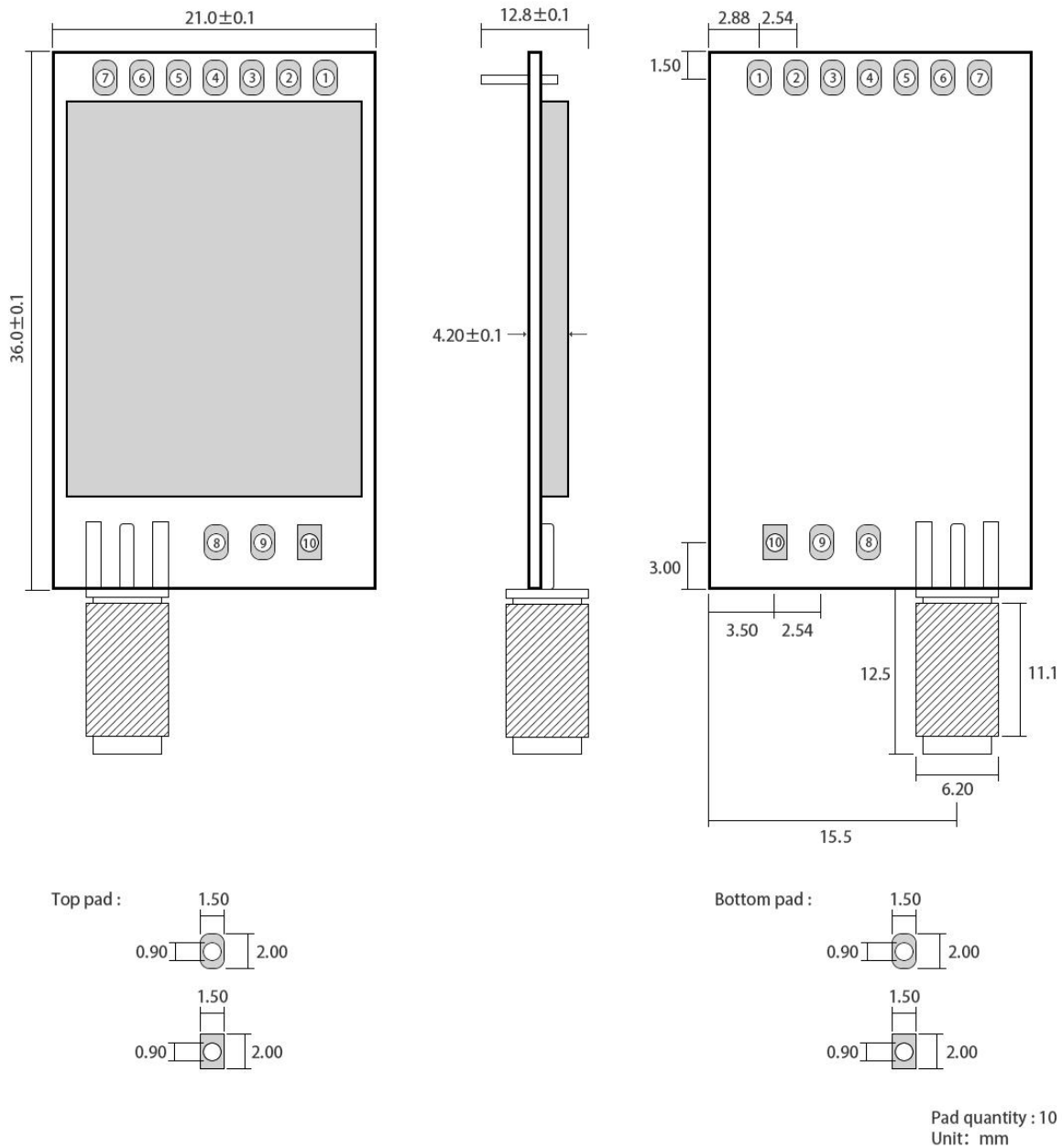

Pin No.	Pin item	Pin direction	Application
1	M0	Input (weak pull-up)	Work with M1 to decide 4 working modes of module (can be suspended, internal pull-up resistor).
2	M1	Input (weak pull-up)	Work with M0 to decide 4 working modes of module (can be suspended, internal pull-up resistor).
3	RXD	Input	TTL UART input, connects to external TXD output pin.

4	TXD	Output	TTL UART output, connects to external RXD input pin.
5	AUX	Output	To indicate module 's working status & wakes up the external MCU. During the procedure of self-check initialization, the pin outputs low level.
6	VCC		Module power supply positive reference, voltage range: 2.6V ~ 3.3V DC
7	GND		Ground
8	GND		Ground
9	GND		Ground
10	GND		Ground

4. Connect to MCU

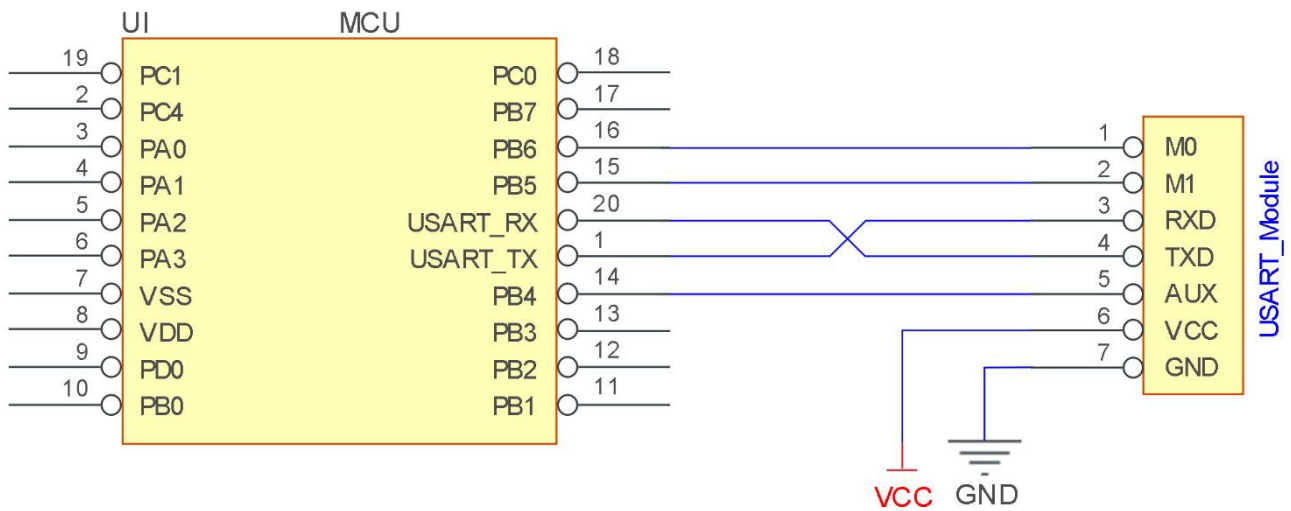

No.	Description (STM8L MCU)
1	The UART module is TTL level, please connect with TTL level MCU.
2	For some MCU works at 5V DC, it may need to add 4~10K pull-up resistor for the TXD & AUX pin.

5. Function description

5.1 Module reset

When the module is powered on, AUX outputs low level immediately, conducts hardware self-check and sets the operating mode based on user's parameters. During the process, the AUX remains low level. After the process completed, the AUX outputs high level and starts to work as the operating mode combined by M1 and M0. Therefore, users need to wait the AUX rising edge as the start of module's normal work.

5.2 AUX description

AUX P is used as indication for wireless sending & receiving buffer and self-check.

It can indicate whether there are data that are not sent yet via wireless way, or whether all wireless data has been sent through UART, or whether the module is still in the process of self-check initialization.

5.2.1 Wireless receiving indication

After receiving the valid wireless data, the module will immediately pull AUX low and start UART to output data and then pull up AUX after the data output is completed.



5.2.2 Wireless transmission indication

After receiving the serial port data, the module will immediately pull down AUX and start sending data wirelessly and after all the data is sent, pull up AUX.

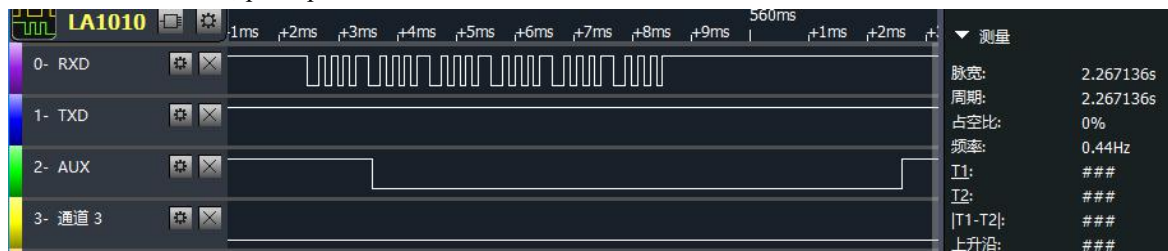

5.2.3 Reset and exit sleep mode

Only when resetting and exiting sleep mode



Timing Sequence Diagram of AUX when self-check

5.3.4 Notes for AUX

The function 1 and function 2 mentioned above have low output priority, that is, if any output low condition is met, AUX outputs a low level; when all low level conditions are not met, AUX outputs a high level.

When the AUX output is low, it indicates that the module is busy, and the operating mode detection will not be performed; when the AUX output is high, the mode switching will be completed.

When users enter other modes from mode 3 (sleep mode) or during the reset process, the module will reset user parameters, during which AUX outputs low level.

5.3.5 Fixed-point mode description

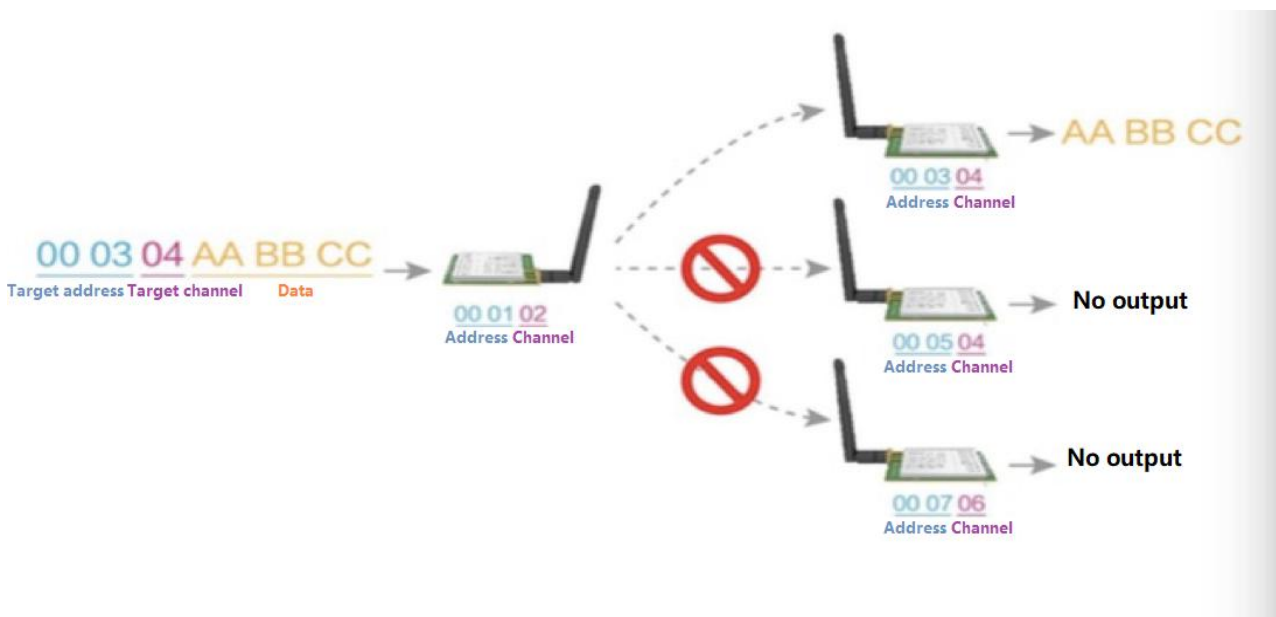

5.3.6 Broadcast transmission

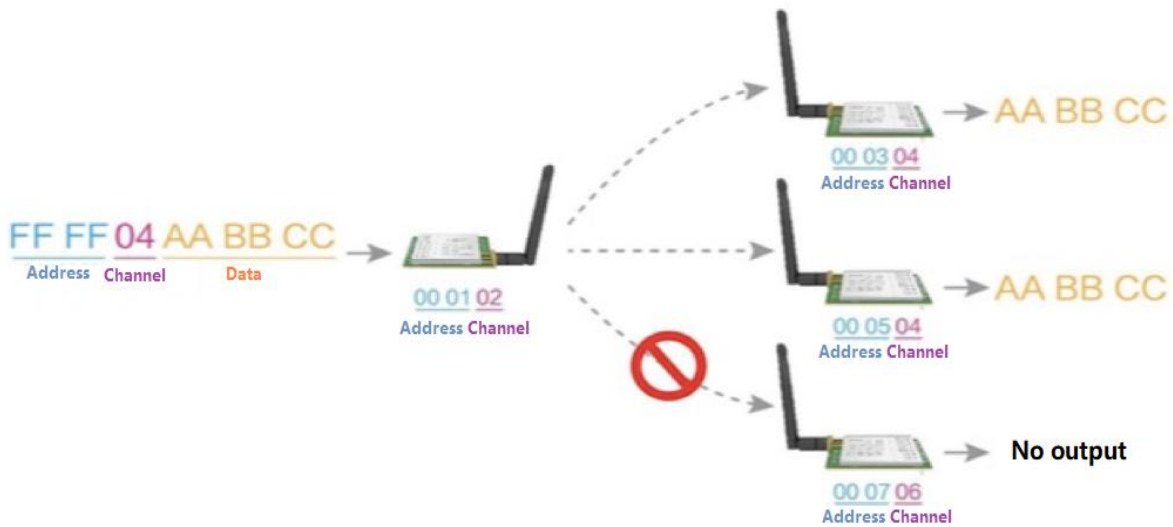

5.3.7 Broadcast address

Example:

- Set the address of module A to 0xFFFF and the channel to 0x04
- When module A is used for transmission (same mode, transparent transmission mode), all receiving module under the 0x04 channel can receive data to achieve the purpose of broadcasting.

5.3.8 Monitor Address

Example: Set the address of module A to 0xFFFF and the channel to 0x04. When module A is used as a receiver, it can receive all the data under the 0x04 channel to achieve the purpose of monitoring.

6. Operating mode

There are four operating modes, which are set by M1 and M0, the details are as follows:

Mode(0-3)	M1	M0	Description	Remark
0 Transmission mode	0	0	UART and wireless channel are open, the module performs data transmission according to the set transmission mode	The transmission method of the sender and receiver must be consistent
1 RSSI mode	0	1	Wireless off and UART opens, the module outputs RSSI signal strength value at 100ms timing	Relative intensity values only
2 Setting mode	1	0	Wireless off, can receive UART command, refer to Command List, fixed baud rate is 9600, 8N1	Parameter configuration
3 Sleep mode	1	1	The module goes to sleep standby mode, and the serial UART and wireless are turned off.	Ultra-lower power consumption sleep

6.1 Mode switching

- Users can combine M0 and M1 with high and low levels to determine the operating mode of the module. Users can use the MCU's 2 GPIOs to control the node switching; after changing M0,M1: the module is idle and after 1ms, it can start working according to the new operating mode; if the module has not transmitted serial port data via wireless, then entering the new operating mode after the transmission completed; if the module receives the wireless data and sends out the data through the serial port, it needs to finish sending before entering the new operating mode; if the module; so the mode switching can only be effective when AUX outputs 1, otherwise the switch will be delayed.
- For example: In mode 0, the user continuously inputs a large amount of data and switches the mode at the same time. The mode switching operation is invalid at this time; the module will process all the user data before performing the new mode detection; so the general recommendation is: Detect the AUX pin output status, wait for 2ms after the AUX output goes high before switching.
- When the module is switched from other modes to sleep mode, if any data has not been processed, the module will enter the sleep mode after processing the data(including receiving and sending). This feature can be used for fast sleep mode to save power consumption; for example: the transmitter module works in mode0, the user initiates serial data "12345",and then does not have to wait for the AUX pin to be idle (high level),and can directly switch to sleep mode, And the user's main MCU will immediately sleep, the module will automatically send all user data through wireless, and automatically enter sleep within 1ms; thus saving the MCU's working time and reducing power consumption.
- Similarly, any mode switch can use this feature. After processing the current mode event, the module will automatically enter the new mode within 1ms; thereby eliminating the user's query of AUX and achieving the goal of fast switching ,For example, switching from the transmission mode to the setting mode; the user MCU can also go to sleep mode in advance before the mode switching, and use the external interrupt function to obtain the AUX change to perform the mode switching.
- This operation mode is very flexible and efficient. It is designed in accordance with the convenience of the user MCU, and can reduce the workload of the entire system as much as possible, improve system efficiency and reduce power consumption.

6.2 Transmission mode (Mode 0)

Type	M0 = 0, M1 = 0
Transmitting	<p>The module receives user data from the serial port, the maximum length of the wireless data packet transmitted by the module is 54 bytes, when the amount of user input data reaches 54 bytes, the module will start wireless transmission. At this time, the user can continue to enter the data that needs to be transmitted.</p> <p>When the user needs to transmit less than 54 bytes, the module waits for about 20ms. If there is no user data to continue to input, the data is considered to be terminated. At this time, the module sends all data via wireless.</p> <p>When the module receives the first user data, AUX outputs low level. When the module puts all data into the RF chip and starts transmitting, AUX outputs high level.</p> <p>At this point, it indicates that the last packet of wireless data has been transmitted, and the user can continue to enter data.</p> <p>Data packets sent through mode 0 can only be received by the receiving module in mode 0.</p>
Receiving	<p>The module is on the wireless receiving function all the time and can receive data packets from mode 0.</p> <p>After receiving the data packet and the module AUX outputs a low level, it starts sending wireless data through the serial port TXD pin. After all wireless data is output through the serial port, the module outputs AUX high level.</p>

6.3 RSSI Mode (Mode 1)

Type	M0 = 1, M1 = 0
Transmitting	No wireless transmission is allowed, the received serial data will be discarded.
Receiving	<p>Can not receive air wireless data, only scan the signal strength of the current channel, and output a strength value (relative value) through the serial port every 100ms.</p> <p>Numerical calculation method: signal strength = -(256 (decimal)-data (decimal)) dBm</p> <p>If the hexadecimal value output by the serial port is 0x91, the actual signal strength is: -(256 (decimal)-145 (decimal)) = -111 dBm</p>

6.4 Setting Mode (Mode 2)

Type	M0 = 0, M1 = 1
transmitting	No wireless transmission is allowed, the received serial data will be discarded.
receiving	Unable to receive wireless data
configuration	Can be used for module parameter setting, use serial port 9600, 8N1, set module working parameters according to specific instruction format
Note	<p>When entering from the setting mode to other modes, the module will reconfigure the parameters. During the configuration, AUX remains low level;</p> <p>It outputs a high level after finished, so it is recommended that the user detect the rising edge of AUX.</p>

6.5 Sleep Mode (Mode 3)

Type	M0 = 1, M1 = 1
transmitting	Unable to transmit wireless data
receiving	Unable to receive wireless data
others	When the module is in the ultra-low power consumption state, all other functions of are turned off, and the sleep mode can only be exited through the state switch of M1M0.

6.6 Fast communication test

Step	Description
1	Connect E49-400T20D module to the E49-TBL backplane, and then plug into the USB test board (E15-USB-T2), plug into the computer to ensure that the driver has been installed correctly; Plug in the mode selection jumper cap on the USB test board (M1 = 0, M0 = 0)
2	Select 3.3V (the module supports 2.6 ~ 3.3V).
3	Run the "Serial Debug Assistant" software and select the correct serial port number and observe the sending window and the corresponding receiving window

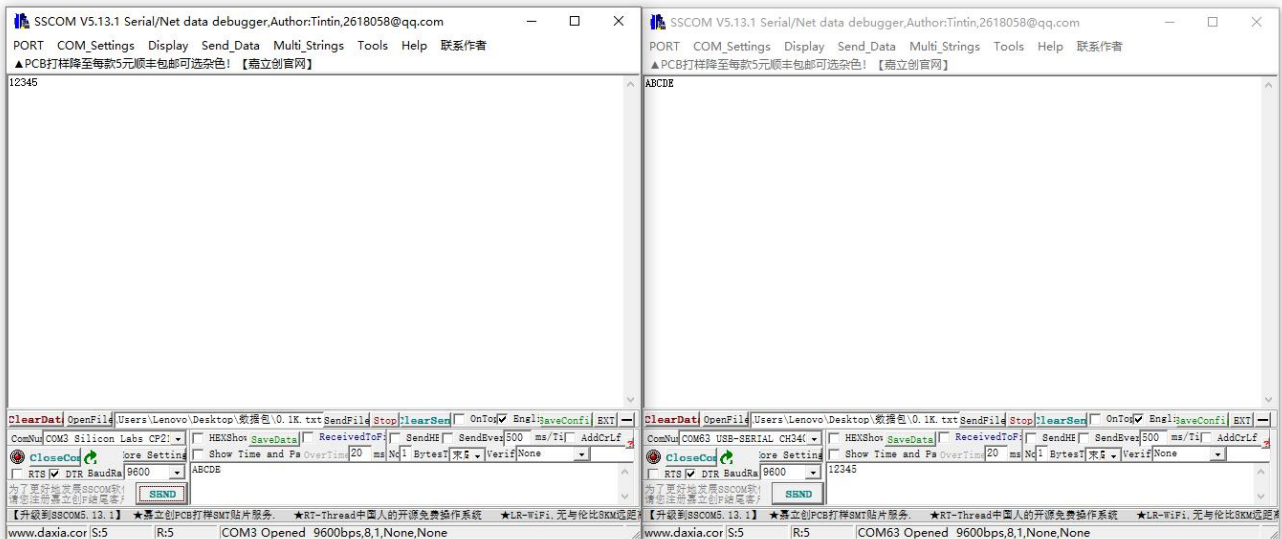

7. Command format

Command mode (Mode 2: M0 = 0, M1 = 1), the list of supported commands is as follows (when set, only 9600, 8N1 format is supported):

No.	Command format	Description
1	C0+operating parameter	Send C0 + 5 byte working parameters in hexadecimal format, a total of 6 bytes and must be sent continuously (save when power off)
2	C1+C1+C1	Send three C1s in hexadecimal format. The module returns the saved parameters and must be sent continuously.
3	C2+operating parameter	Send C2 + 5 bytes working parameter in hexadecimal format, a total of 6 bytes and must be sent continuously(do not save when power off)
4	C3+C3+C3	Send three C3s in hexadecimal format. The module returns version information and must be sent continuously.

7.1 Factory default parameter

Model	Factory default parameter value: C0 00 00 19 2E 00					
Module type	Frequency	Address	Channel	Air rate	Baud rate	Transmitting power
E49-400T20D	433MHz	0x0000	0x2E	2.4kbps	9600	20

7.2 Reading operating parameter

Command format	Description
C1+C1+C1	In the setting mode (M0 = 0, M1 = 1), issue a command to the module serial port (HEX format): C1 C1 C1, The module will return the current configuration parameters, such as: C0 00 00 18 20 00

7.3 Version number reading

Command format	Description
C3+C3+C3	In the setting mode (M0 = 0, M1 = 1), issue a command to the module serial port (HEX format): C3 C3 C3, The module will return the current configuration parameters, such as: C3 49 xx yy; 49 here represents the module model (E49 series), xx is the version number, and yy refers to other features of the module (users can ignore).

7.4 Parameter setting command

No.	Item	Description	Remark
0	HEAD	Fixed 0xC0 or 0xC2, it means this frame data is control command	<ul style="list-style-type: none"> Must be 0xC0 or 0xC2 C0: Save the parameters when power off C2: Do not save the parameters when power off
1	ADDH	High address byte of module (default 00H)	00H-FFH
2	ADDL	Low address byte of module (default 0H)	00H-FFH
3	SPED	Rate parameters, including serial rate and air rate 7, 6: Serial parity bit 00: 8N1(default) 01: 8O1 10: 8E1 11: 8N1 ----- 5, 4, 3 TTL serial speed (bps) 000: Serial baud rate is 1200 001: The serial port baud rate is 2400 010: The serial port baud rate is 4800 011: Serial baud rate is 9600 (default) 100: The serial port baud rate is 19200 101: Serial baud rate is 38400 110: Serial baud rate is 57600 111: Serial baud rate is 115200 ----- 2, 1, 0 Wireless air data rate (bps) 000: Air data rate is 1.2k 001: Air data rate is 2.4k (default) 010: Air data rate is 4.8k 011: Air data rate is 9.6k 100: Air data rate is 19.2k 101: Air data rate is 50k 110: Air data rate is 100k 111: Air data rate is 200k	----- UART baud rate can be different between communication parties The UART baud rate has nothing to do with wireless transmission parameters & won't affect the wireless transmit / receive features. ----- ----- <ul style="list-style-type: none"> The lower the air data rate, the longer the transmitting distance, better anti-interference performance and longer transmitting time The air data rate must keep the same for both communication parties.
4	CHAN	7, 6, 5, 4, 3, 2, 1, 0 Communication channel Communication frequency (410M + CHAN * 0.5M) (Default 0x2E: 433M)	----- <ul style="list-style-type: none"> 00H-C8H, correspond to 410~510 MHz
5	OPTION	7, Fixed transmission enabling bit (similar to MODBUS) 0: Transparent transmission mode 1 : Fixed transmission mode ----- 6, 5, 4, 3, 2 Reserved bit, write 0 ----- 1, 0 Transmission power (approximation)	<ul style="list-style-type: none"> In fixed transmission mode, the first three bytes of each user's data frame can be used as high/low address and channel. The module changes its address and channel when transmit. And it will revert to original setting after complete the process.

		00: 20 dBm (default) 01: 17 dBm 10: 14 dBm 11: 10 dBm	----- <ul style="list-style-type: none"> ● The external power must make sure the ability of current output more than 100mA and ensure the power supply ripple within 100mV. ● Low power transmission is not recommended due to its low power supply efficiency.
--	--	--	--

For example: The meaning of No.3 "SPED" byte:

The binary bit of the byte	7	6	5	4	3	2	1	0
Configured by users	0	0	0	1	1	0	0	1
Meaning	UART parity bit 8N1		UART baud rate is 9600			Air data rate 2.4k		
Corresponding hexadecimal	1				9			

8. Hardware design

- It is recommended to use a DC stabilized power supply. The power supply ripple factor is as small as possible, and the module needs to be reliably grounded. ;
- Please pay attention to the correct connection of the positive and negative poles of the power supply. Reverse connection may cause permanent damage to the module ;
- Please check the power supply to ensure it is within the recommended voltage otherwise when it exceeds the maximum value the module will be permanently damaged ;
- Please check the stability of the power supply, the voltage can not be fluctuated frequently ;
- When designing the power supply circuit for the module, it is often recommended to reserve more than 30% of the margin, so the whole machine is beneficial for long-term stable operation. ;
- The module should be as far away as possible from the power supply, transformers, high-frequency wiring and other parts with large electromagnetic interference. ;
- High-frequency digital routing, high-frequency analog routing, and power routing must be avoided under the module. If it is necessary to pass through the module, assume that the module is soldered to the Top Layer, and the copper is spread on the Top Layer of the module contact part(well grounded), it must be close to the digital part of the module and routed in the Bottom Layer ;
- Assuming the module is soldered or placed over the Top Layer, it is wrong to randomly route over the Bottom Layer or other layers, which will affect the module's spurs and receiving sensitivity to varying degrees ;
- It is assumed that there are devices with large electromagnetic interference around the module that will greatly affect the performance. It is recommended to keep them away from the module according to the strength of the interference. If necessary, appropriate isolation and shielding can be done ;
- Assume that there are traces with large electromagnetic interference (high-frequency digital, high-frequency analog, power traces) around the module that will greatly affect the performance of the module. It is recommended to stay away from the module according to the strength of the interference. If necessary, appropriate isolation and shielding can be done.
- If the communication line uses a 5V level, a 1k-5.1k resistor must be connected in series (not recommended, there is still a risk of damage) ;
- Try to stay away from some physical layers such as TTL protocol at 2.4GHz , for example: USB3.0 ;
- The mounting structure of antenna has a great influence on the performance of the module. It is necessary to ensure that the antenna is exposed, preferably vertically upward. When the module is mounted inside the case, use a good antenna extension cable to extend the antenna to the outside ;
- The antenna must not be installed inside the metal case, which will cause the transmission distance to be greatly weakened.

9. FAQ

9.1 Communication range is too short

- The communication distance will be affected when obstacle exists.
- Data lose rate will be affected by temperature, humidity and co-channel interference.
- The ground will absorb and reflect wireless radio wave, so the performance will be poor when testing near ground.
- Sea water has great ability in absorbing wireless radio wave, so performance will be poor when testing near the sea.
- The signal will be affected when the antenna is near metal object or put in a metal case.
- Power register was set incorrectly, air data rate is set as too high (the higher the air data rate, the shorter the distance).
- The power supply low voltage under room temperature is lower than 2.5V, the lower the voltage, the lower the transmitting power.
- Due to antenna quality or poor matching between antenna and module.

9.2 Module is easy to damage

- Please check the power supply to ensure that it is between the recommended power supply voltage. If the maximum value is exceeded, the module will be permanently damaged.
- Please check the stability of power source, the voltage cannot fluctuate too much.
- Please make sure anti-static measure are taken when installing and using, high frequency devices have electrostatic susceptibility.
- Please ensure the humidity is within limited range, some parts are sensitive to humidity.
- Please avoid using modules under too high or too low temperature.

9.3 BER(Bit Error Rate) is high

- There are co-channel signal interference nearby, please be away from interference sources or modify frequency and channel to avoid interference;
- Poor power supply may cause messy code. Make sure that the power supply is reliable.
- The extension line and feeder quality are poor or too long, so the bit error rate is high;

10. Welding guidance

10.1 Reflow Soldering Temperature

Profile Feature	Curve feature	Sn-Pb Assembly	Pb-Free Assembly
Solder Paste	Solder paste	Sn63/Pb37	Sn96.5/Ag3/Cu0.5
Preheat Temperature min (T _{smin})	Minimum preheating temperature	100°C	150°C
Preheat temperature max (T _{smax})	Maximum preheating temperature	150°C	200°C
Preheat Time (T _{smin} to T _{smax})(t _s)	Preheating time	60-120 sec	60-120 sec
Average ramp-up rate(T _{smax} to T _p)	Average rising rate	3°C/second max	3°C/second max
Liquidous Temperature (T _L)	Liquid phase temperature	183°C	217°C
Time (t _L) Maintained Above (T _L)	Time above liquidus	60-90 sec	30-90 sec
Peak temperature (T _p)	Peak temperature	220-235°C	230-250°C
Average ramp-down rate (T _p to T _{smax})	Average descent rate	6°C/second max	6°C/second max
Time 25°C to peak temperature	Time of 25 °C to peak temperature	6 minutes max	8 minutes max

10.2 Reflow Soldering Curve

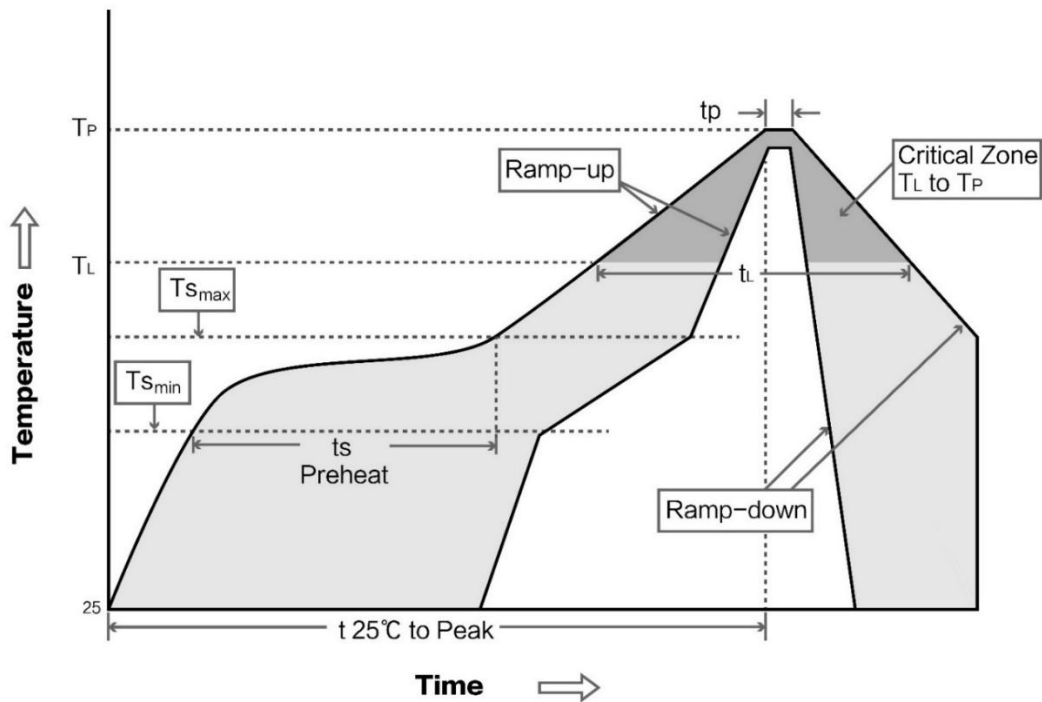

11. Related Model

Model No.	Chip	Frequency Hz	Transmit power dBm	Test distance km	Air data rate bps	Packaging	Size mm	Antenna
E49-400T20S	-	433M	20	1	1.2k~200k	SMD	26 * 16	IPEX/Stamp hole

12. Antenna guidance

12.1 Antenna recommendation

Antennas play an important role in the communication process, usually low-quality antennas will greatly affect the communication system. Therefore, we recommend some antennas as supporting antennas of our company with excellent performance and reasonable price.

Model No.	Type	Frequency Hz	Interface	Gain dBi	Height	Cable	Function feature
TX433-NP-4310	Flexible PCB antenna	433M	SMA-J	2	43.8*9.5mm	-	Built-in flexible FPC antenna
TX433-JW-5	Rubber antenna	433M	SMA-J	2	50mm	-	Flexible & omnidirectional
TX433-JWG-7	Rubber antenna	433M	SMA-J	2.5	75mm	-	Flexible & omnidirectional
TX433-JK-20	Rubber antenna	433M	SMA-J	3	210mm	-	Flexible & omnidirectional
TX433-JK-11	Rubber antenna	433M	SMA-J	2.5	110mm	-	Flexible & omnidirectional
TX433-XP-200	Sucker antenna	433M	SMA-J	4	19cm	200cm	Sucker antenna, high gain
TX433-XP-100	Sucker antenna	433M	SMA-J	3.5	18.5cm	100cm	Sucker antenna, high gain
TX433-XP-300	Sucker antenna	433M	SMA-J	6	96.5cm	300cm	Car mounted sucker antenna, ultra-high gain
TX433-JZG-6	Rubber antenna	433M	SMA-J	2.5	52mm	-	Short straight & omnidirectional
TX433-JZ-5	Rubber antenna	433M	SMA-J	2	52mm	-	Short straight & omnidirectional
TX490-XP-100	Sucker antenna	490M	SMA-J	50	12cm	100cm	Sucker antenna, high gain
TX490-JZ-5	Rubber antenna	490M	SMA-J	50	50mm	-	Short straight & omnidirectional

13. Batch packaging

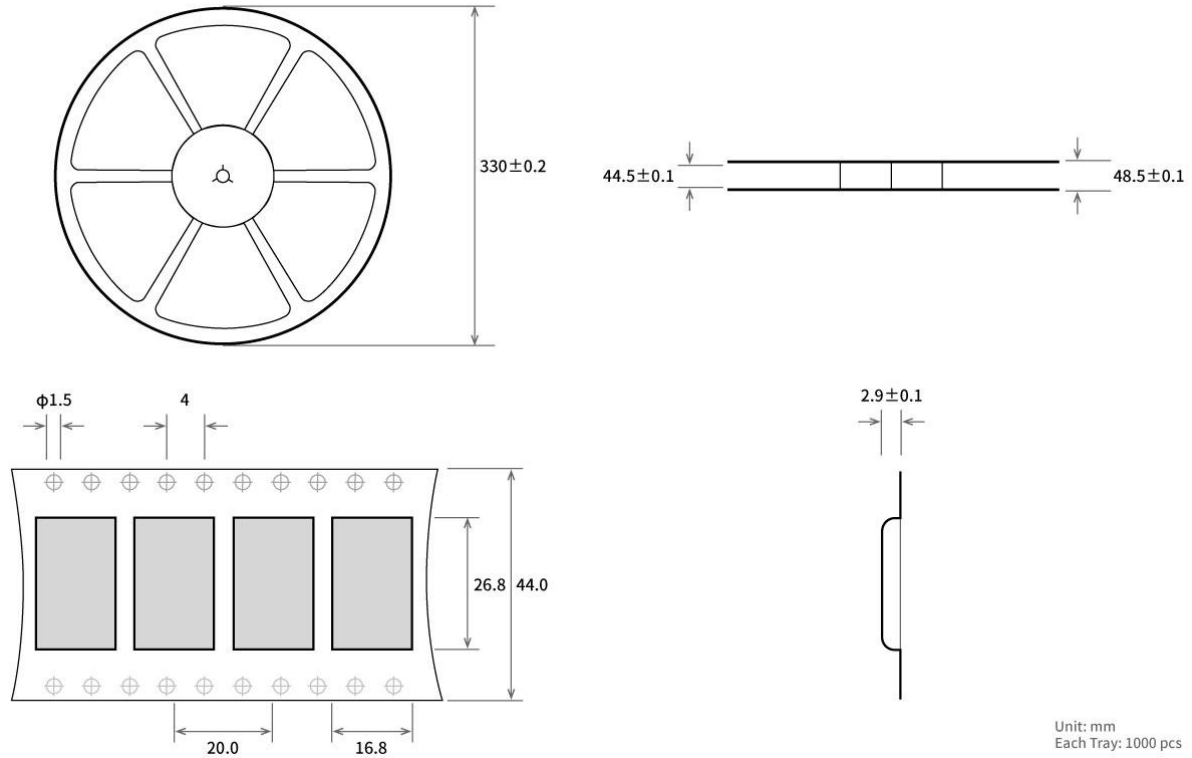

Revision history

Version	Date	Description	Issued by
1.0	2020-01-09	Initial version	Ren

About us

Sales hotline: 4000-330-990

Tel: 028-61399028

Support: support@cdebyte.com

Website: www.ebyte.com

Address: Innovation Center B333~D347, 4# XI-XIN road, High-tech district (west), Chengdu, Sichuan, China



Chengdu Ebyte Electronic Technology Co.,Ltd.