

# USER MANUAL OF LITHIUM MPPT SOLAR CHARGE CONTROLLER

For Models: V120, V121 versions

## Important note

All expressed or written warranties shall be deemed void if controller has been opened, disassembled, altered or used in any manner inconsistent with written instructions. All warranties shall also be deemed void if controller is overpowered, input PV polarity reversed or battery polarity reversed. It's user's responsibility to control input wattage and connect all polarity correctly to avoid damaging controller.

## Features

- 30A/40A/50A/60A MPPT solar charge controller
- MPPT technology
- Built-in High Performance DSP controller
- PV Start ON&BMS Activation
- Lithium mode or 3-stage charging mode for Lead-acid battery
- The MPPT track speed is 5 times faster than traditional controllers
- The charging voltage accuracy is  $\pm 0.2V$
- Output limited current protection, Overcharge protection, Over-temperature protection
- Suitable for battery types such as lead acid, vented gel, and lithium battery, etc

## Basic Parameter

Models	30A	40A	50A	60A
Battery voltage <b>Not voltage automatic recognition</b>	12V system: 9V-15V; 24V system: 18V-29V 36V system: 30V-39V; 48V system: 40V-60V			
Overcharging protection voltage	12V Bat: 15V; 24V Bat: 30V; 36V Bat: 45V; 48V Bat: 60V			
Limited current protection	31A	42A	51A	61A
Max efficiency	$\geq 98.2\%$			
PV utilization	$\geq 99\%$			

Protection function	
Temperature protection	75°C / 167°F
Fan-on temperature	>45°C / 113°F
Fan-off temperature	<40°C / 104°F
Properties	
Dimensions	214x115x50mm / 8.4*4.5*1.97in
Net weight	1.2KG / 2.65LB
Electromagnetic compatibility	Accord to EN61000, EN55022, EN55024
Enclosure	IP21
Environmental temperature	-20°C ~ +55°C / -4°F ~ + 131°F
Storage temperature	-40°C ~ +75°C / -40°F ~ + 167°F

### How to choose PV Module

Models		30A	40A	50A	60A
Maximum PV Module Input Power <b>(Never overpowered)</b>	For 12V Battery	≤400W	≤480W	≤600W	≤720W
	For 24V Battery	≤720W	≤960W	≤1200W	≤1440W
	For 36V Battery	≤1000W	≤1400W	≤1800W	≤2100W
	For 48V Battery	≤1200W	≤1700W	≤2200W	≤2800W
PV Module Open Circuit Voltage	For 12V Battery	DC20V~DC80V			
	For 24V Battery	DC37V~DC105V			
	For 36V Battery	DC50V~DC160V			
	For 48V Battery	DC72V~DC160V			
Maximum PV Module Open Circuit Voltage <b>(Never over max PV Voc)</b>	For 12V Battery: 80V; For 24V battery: 105V; For 36V battery: 160V; For 48V battery: 160V.				

Notes: Voc of PV should be in the correct range and when it's 1.5 or 2 times than battery voltage, then it's best efficiency. Please choose the PV modules with right Voc.

## How choose Two-pole Circuit Breaker and Wires

Models	30A	40A	50A	60A
Pure copper wires	6mm <sup>2</sup> /9AWG	6mm <sup>2</sup> /9AWG	2PCS 6mm <sup>2</sup> /9AWG	2PCS 6mm <sup>2</sup> /9AWG
Circuit Breaker	2PCS 63A	2PCS 63A	2PCS 63A	2PCS 100A

### Warning

- Be aware that only qualified professionals should install these controllers. Please read full manual before installing. Please don't set any parameters if you are not a professional installer. The controller will work well on defaults for Lead acid. Lithium battery require parameter change.
- The controllers should be installed indoors only. Keep controller away from water. Don't use wet towel to wipe controller.
- **Never open the controller case without permission. Never reverse input PV polarity.**  
**Never reverse the battery polarity. Never overpower input PV.**
- The controller can't connect 110V or 240V or any other AC appliances in the OUT+, OUT-terminal. The output is only for DC load current less than 5A. If your battery is 48V, then load should be 48V and current less than 5A.
- Must use two-pole circuit breakers, and make sure the input and output are using separate circuit breakers.
- Use the pure copper wires and connect all polarity correctly.
- Please don't insert any meter or other devices between controller and battery or controller and PV.
- It's important to open terminal lugs 100% before inserting wire into terminal block. Then tighten and recheck to make sure wires are secure.
- Please note that running maximum wattage could be a hazard if atmospheric conditions allow for PV array to over power unit. There are times that a 2800 rated PV array can produce in excess of 3400 watts. This can damage controller. It is best to allow room for that occurrence.
- Please refer to an awg wire size calculator to properly size your wire from your PV, Battery, and Inverter. When in doubt, larger size wire is always a better choice.

## Reminder

- PV Start ON&BMS Activation, For 24V, 36V and 48V systems, you could start on from PV or batteries. For 12V system, you should start on from PV firstly.
- Keep controller in an environmental temperature of  $-22^{\circ}\text{C}\sim+55^{\circ}\text{C}$ . Avoid direct sunlight.
- Keep good heat dissipation.
- Please contact us or authorized distributor if any doubts before installation or any errors after installed.

## Installation steps

1. Use one two-pole circuit breaker in “OFF” position. Install this circuit breaker between controller and battery. Connect batteries to controller ensuring correct polarity. Set circuit breaker to “ON” position. Startup screen will appear with model and version displayed. Set the controller parameter that you want (See Manual Setting steps) and reboot controller. Double check the settings to ensure successful. Turn “OFF” the circuit breaker.
2. Take another two-pole circuit breaker in “OFF” position. Install this circuit breaker between controller and PV modules. Make sure the PV polarity is correct, then connect PV wires to controller PV Input. Ensure all wire connection are stable, if not, damage to CPU will result.
3. Turn “ON” the circuit breaker between controller and batteries, and turn “ON” the circuit breaker between controller and PV modules.
4. The controller LCD displays the parameters if all is correct.

**(If it's 12V controller, you need to connect PV and Battery to start on, then disconnect PV to set the controller)**

## How to connect diagram

For 30A and 40A, you can connect one wire to one PV+ and another wire to one PV-.

For 50A and 60A, please connect two wires to two PV+ and another two wires to two PV-.

For BAT+ and BAT-, it's same way to connect wires as above.

**( See diagram on next page)**

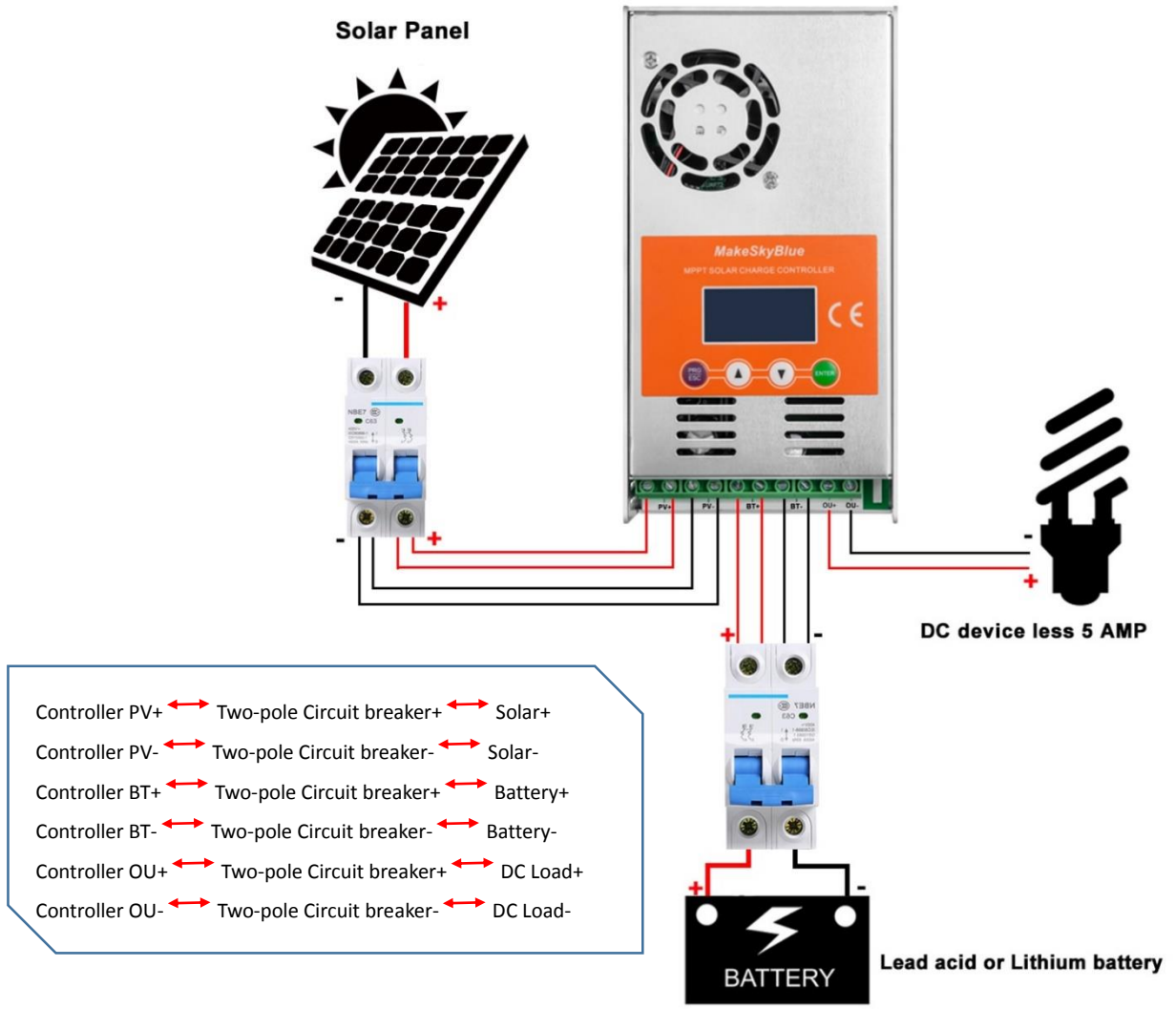

**How to make controllers in parallel**

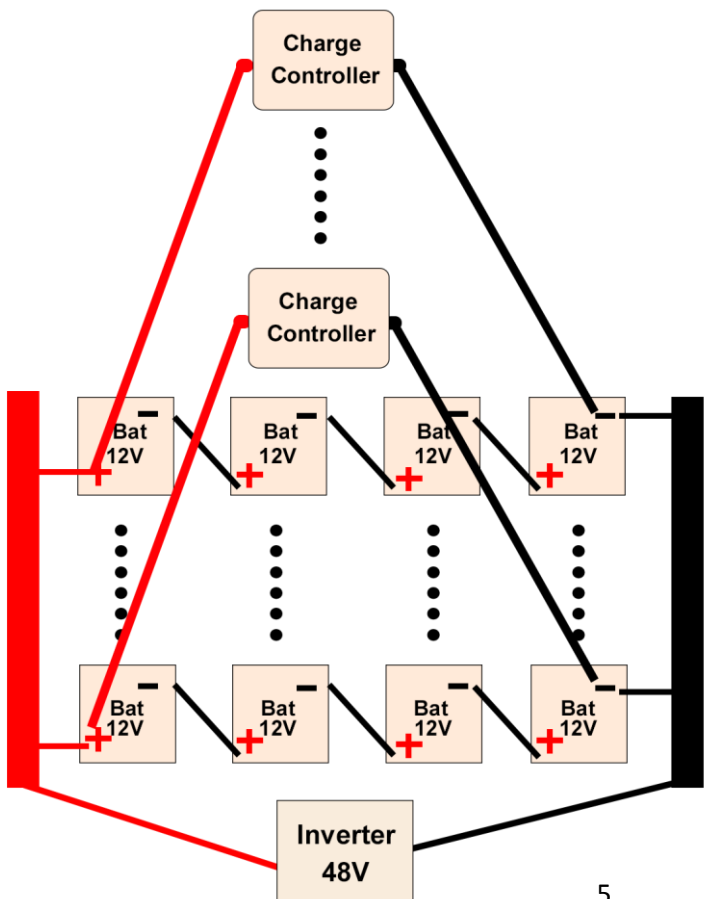

Make sure all wires are same size and length. Wire resistance is very important when installing parallel units and battery banks

LCD display	
1	PV voltage / Output power
2	Battery voltage / Charging current
3	Working mode/Error code/Temperature
4	ACC Power Generation

Working mode	
3.0	Night mode, no charging
4.0	MPPT mode
7.0	Absorption mode
8.0	Floating mode

## Troubleshooting

Code	Description	How to solve
18	Input PV voltage is low	Increase the PV voltage
60	Over-temperature protection	Fan will work and temperature reduction automatically
63	Battery voltage is high	Battery high voltage protection and wait for recovery
65	Battery voltage is low	Battery over-discharge and wait for recovery
71	Input PV voltage is high	Decrease the PV voltage, refer to correct Voc range
73	Over-charging current	Decrease the PV power, refer to correct Voc range
74	Output load is short	Disconnect the load and press ENT over 5 seconds

## Manual Setting

Reminder: The controller will work well on default setting except lithium battery.

**Caution!** Disconnect the PV modules before setting the controller (If it's 12V controller, you need to connect PV and Battery to start on, then disconnect PV to set the controller). When you set up all steps, please reboot the controller to see if all setting is successful.

- D00** Press the button **PRG**, then LCD displays D00. This is setting for load working time (Default is 24-hour). Press **ENTER** until numbers flash, then press **UP/DOWN** to set up time that you want, press **ENTER** to confirm it. This output voltage is same as battery. The load is only for small DC load less 5AMP current. If no load, just leave it.
- D01** Press the button **UP**, Voltage can be set from 12V-17V. This is default value of

floating voltage. Press **ENTER** until numbers flash, then press **UP/DOWN** to set up voltage that you want, press **ENTER** to confirm it.

3. **D02** Continue to press the button **UP**, Voltage can be set from 12V–17V. This is highest constant voltage for battery. Press **ENTER** until numbers flash, then press **UP/DOWN** to set up voltage that you want, press **ENTER** to confirm it.
4. **D03** Continue to press the button **UP**, LCD shows 10.0. This is protection value of battery discharge. Press **ENTER** until numbers flash, then press **UP/DOWN** to set up voltage that you want, press **ENTER** to confirm it. It means it's protected when 12V battery is less 10.0V and there is no output power from OU+ and OU-.
5. **D04** Continue to press the button **UP**, LCD shows 00. 00 is default for lead acid batteries. If it's for lithium battery, please press **ENTER** until numbers flash, then press **UP/DOWN** to choose 01, press **ENTER** to confirm it. Step 2 (D01) is not useful when you choose 01 for lithium battery. And the voltage in step 3 (D02) will be highest charging voltage for lithium battery. Press **ESC** to exit the setting menu. Reboot the controller and check settings again.
6. **D05** Clear password for Wifi version
7. **D06** If you have accurate device and need to calibrate the battery voltage, then calibrate it by D06. Please be cautious to use this function.

For example, if your accurate meter tests the battery and the voltage is 24.5V, but the controller battery voltage reads 24V, then use D06 to calibrate the voltage to 24.5V.

## Dimension

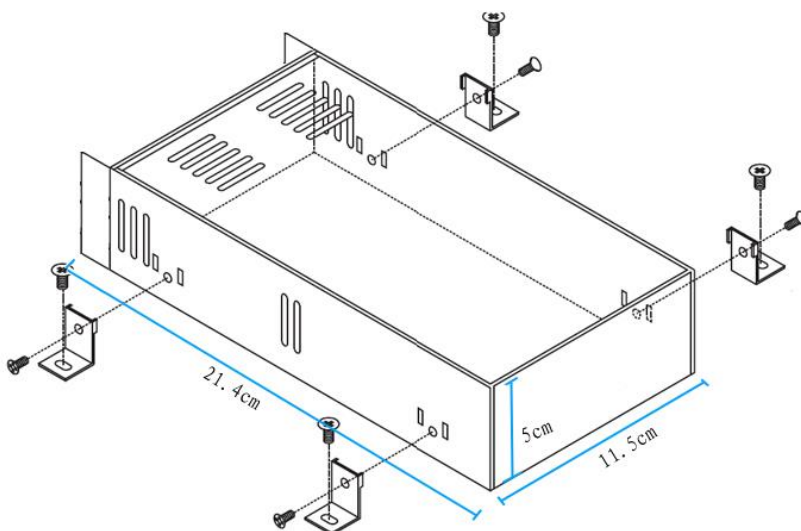

**Notes:** Please use our screws only since it may damage the internal PCB if using other screws.

Please use proper torque to push the screws into casing since it may damage the internal PCB by strong torque.

## Content Included

1 Controller    1 English manual    4 Corner connections    4 Screws for controller casing

## Batteries charge voltage reference

Battery Type	Absorption Voltage ( Constant voltage )			Floating Voltage		
	12V	24V	48V	12V	24V	48V
Vented	14.2V	28.6V	57.2V	13.2V	26.4V	52.80V
Sealed	14.4V	28.8V	57.6V	13.8V	27.6V	55.2V
Gel	14.4 V	28.8V	57.6V	13.8V	27.6V	55.2V
NiCd	14.2V	28.6V	57.2V	14.0V	28.0V	56.0V
Lithium Or special battery	If your battery 12V system, you can set controller charging voltage from 12V–17V. If it's 24V system, you can set voltage from 24V–34V. If it's 36V system, you can set voltage from 36V–51V. If it's 48V system, you can set voltage from 48V–68V.					