

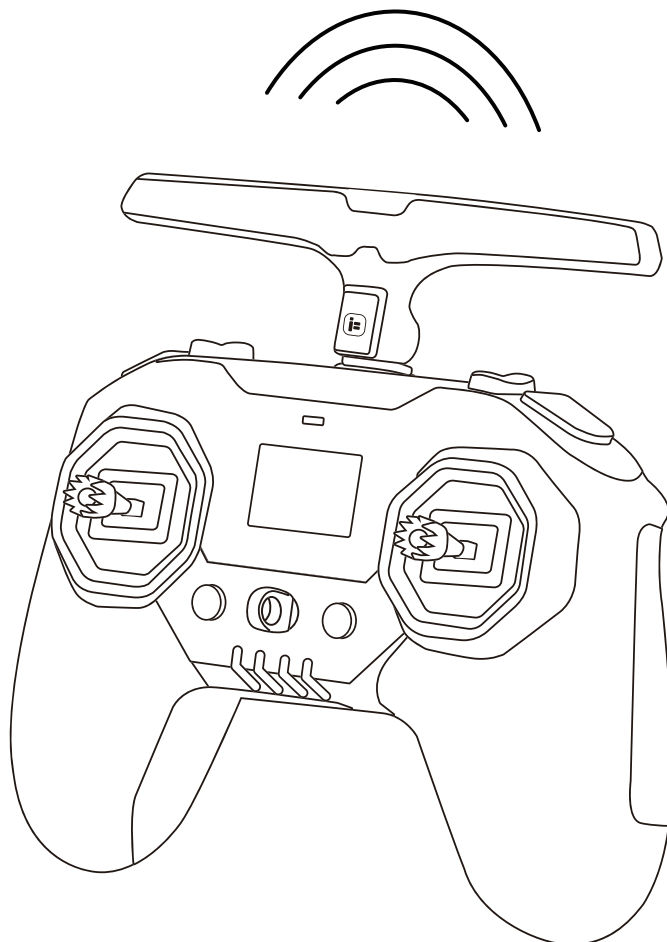

COMMANDO 8

USER MANUAL



V1.0 220119



CONTENT

I. Introduction

II. Power On/Off

III. Battery Level Indicator

IV. Charging Instructions

V. Antenna Adjustment

VI. Binding Instructions

VII. USB Functionality

VIII. Gimbal Mode and Calibration

IX. First Boot Prompt

X. Model Setup and Selection

XI. Product Specifications

Disclaimer

1. This product is used with models such as multi-rotors or fixed-wing aircrafts. Many remote controlled crafts are equipped with powerful motors and sharp propellers. Please use with caution!
2. This product is not a toy, it needs a certain basic knowledge to control. Please read the Manual before use! HuiZhou iFlight Intelligent Technology Ltd. reserves the right to update this Manual.
3. Once you start using this product you agree to have understood, recognized and accepted all the terms and contents of this document. The user agrees to be responsible for his own actions all consequences arising therefrom.

I. Introduction

The iFlight Commando8 remote control supports EdgeTX firmware.

Digital Hall Sensor Gimbals for maximum accuracy and minimum jitter. Built-in ELRS (ExpressLRS) 2400MHz RF module with OpenSource software development and a great community, better signal reception and range without to worry about failsafes. Extreme signal penetration in difficult terrain and highly noise resistant, LongRange capable with 2400MHz.

This remote control is compatible with different receivers when bought with the Multi-protocol and ELRS RF module. D8, D16, S-FHSS and ELRS protocols supported.

Small size, long battery life, foldable Single- or Dual-Band antenna and removeable (upgradeable) stick ends.

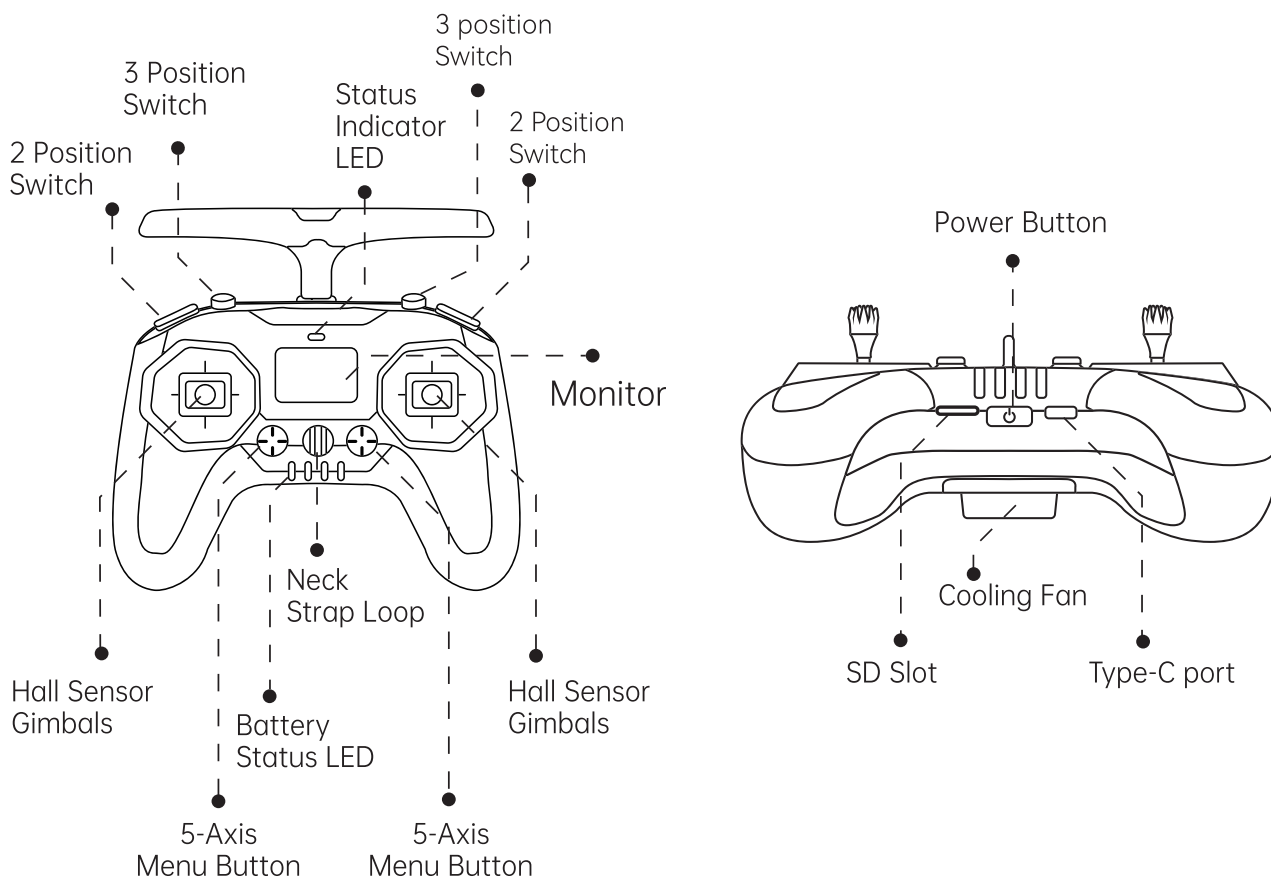

5-Axis Menu Button Definition

Left

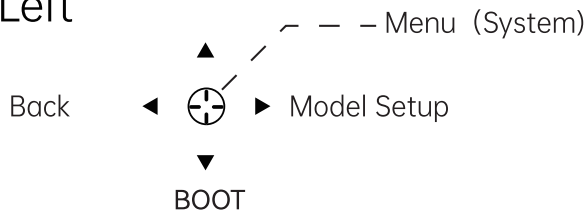

Right

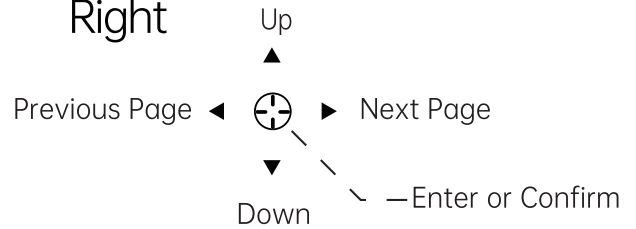

II. Power On/Off

1. Short Press for the LED battery status indicator.
2. Short Press, then press and hold 3 seconds to power ON or OFF.

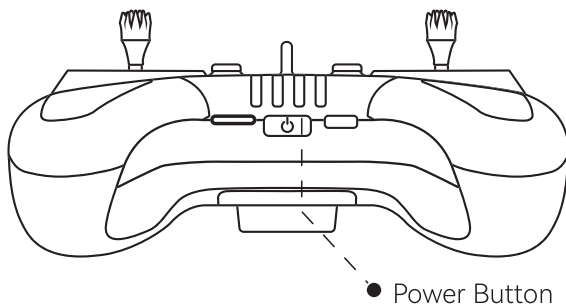

III. Battery Level Indicator

Battery Status LED

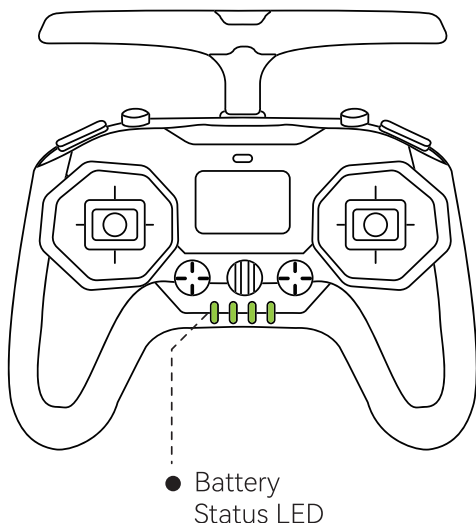

Indicator Light
100% - 80% power, 4 LEDs
80%-60% power, 3 LEDs
60%-40% power, 2 LEDs
40%-20% power, 1 LED
20%-5%, 1 LED and flashing
Below 5%, 1 LED and flashing with continuous beeping
No light and continuous haptic feedback will force automatic shutdown after 2 minutes or lower than 2.8V battery.

IV. Charging Instructions

It is recommended to use a USB charger of 20W or above that supports PD, Huawei FCP, Samsung AFC, MTK PE+1.1/2.0 fast charge and complies with FCC/CE standards. The Commando8 has a built-in Li-ion battery and Type-C fast charging. The nominal battery Voltage is 3.6V, the maximum Voltage is 4.2V. Don't charge damaged or faulty cells and do not charge it unattended. Charge in a safe area away from flammable materials.

The user is responsible for all consequences caused by wrong use or abuse of this product.

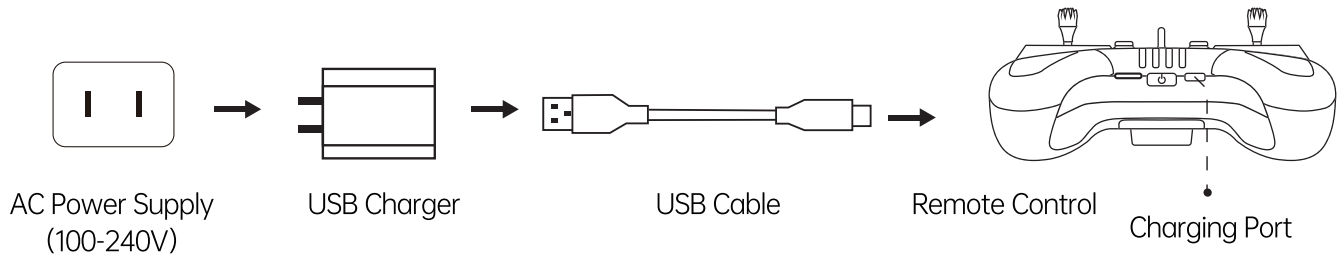

V. Antenna Adjustment

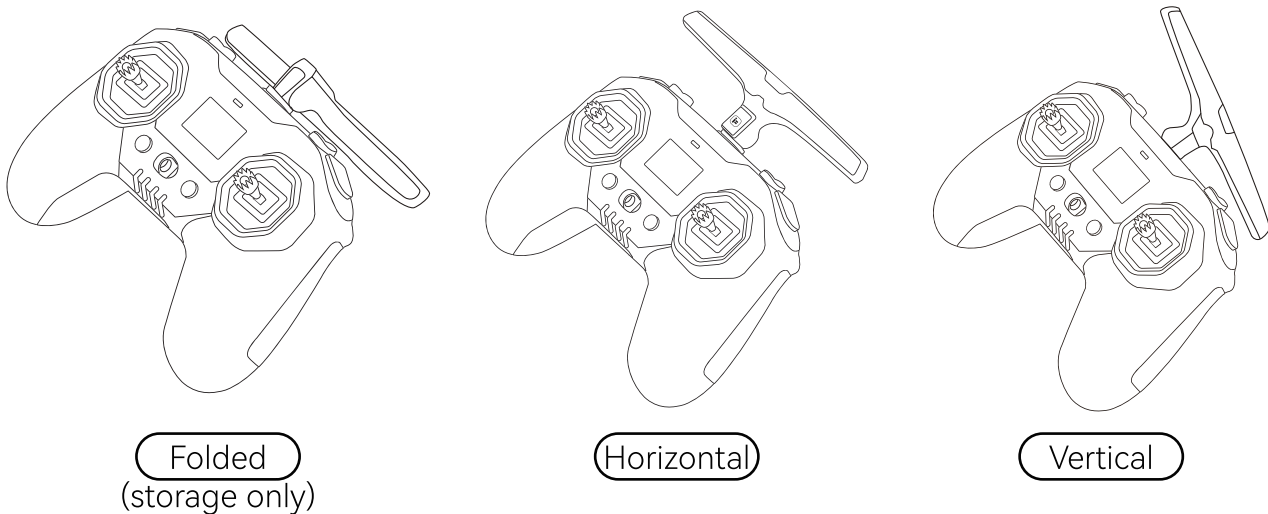

Maintaining Optimal Positioning

When operating a craft, make sure to always be in LOS (line of sight) with the antenna facing towards your model.

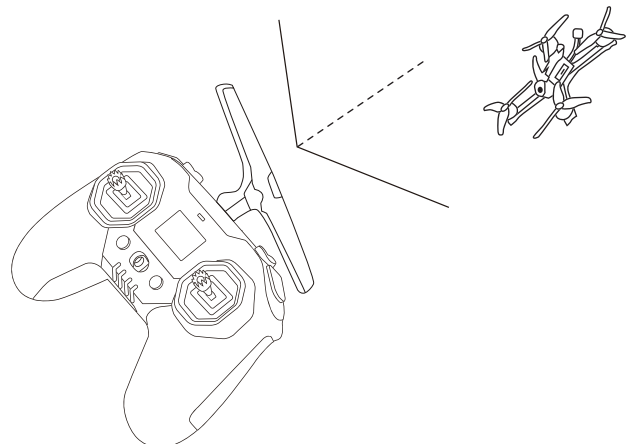

Horizontal antenna signal radiation

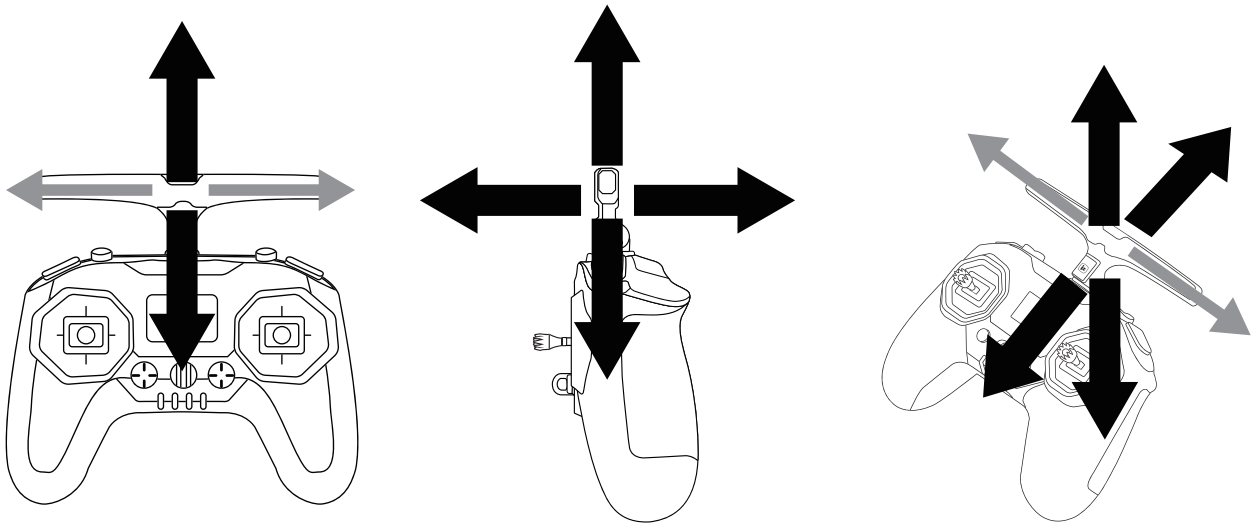

Vertical antenna signal radiation

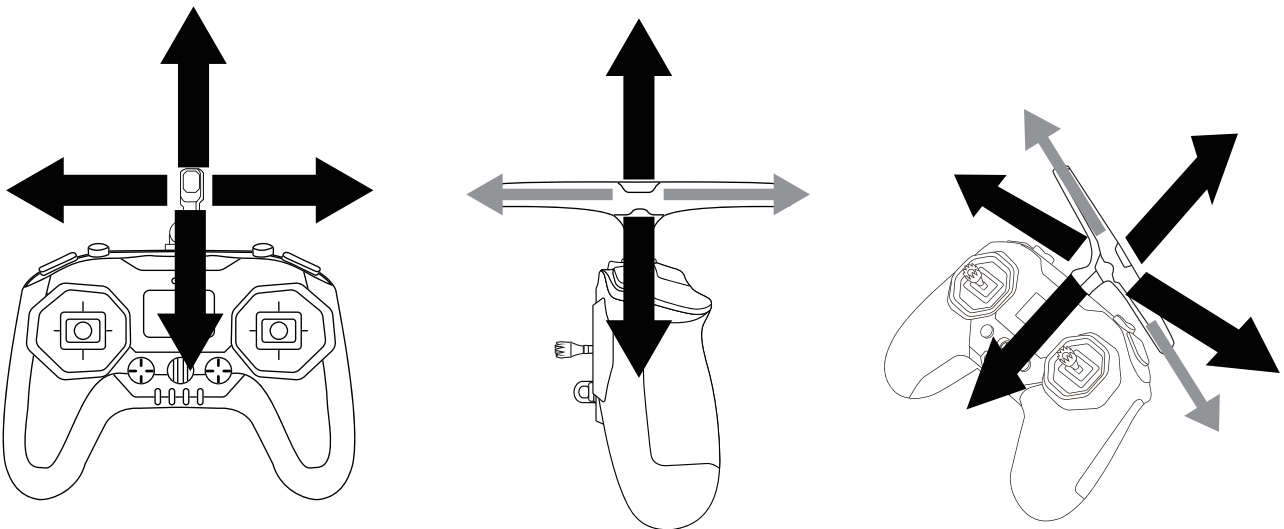

The black arrow in the graphic represents the direction of a strong antenna reception, the gray arrow represents the direction of weak antenna reception.

When the antenna is placed horizontally, the front and upwards/downwards facing directions are the safest to move your craft in. Flying your model to the left, right or behind yourself would cause a weaker signal reception. If you plan to move your aircraft from the left to the right, make sure to use a vertical antenna position.

VI. Binding Instructions

C2500 Multi-Protocol Module

Example: Using the iFlight R81 receiver, Frsky ACCST D8 protocol.

1. Power on the R81 receiver, the receiver LED is off. Press the Bind button for 1 second, the LED turns red. The receiver is now in Bind mode.



▲ 2. Once you power on the radio, hold the left menu button to the right to enter the MODESEL page.



▲ 3. Push the right menu button to the right to go to the next page SETUP (2/12)



▲ 4. Scroll down to the Internal RF and turn on MULTI mode, select Frsky D8 mode and move to BND for the next step.

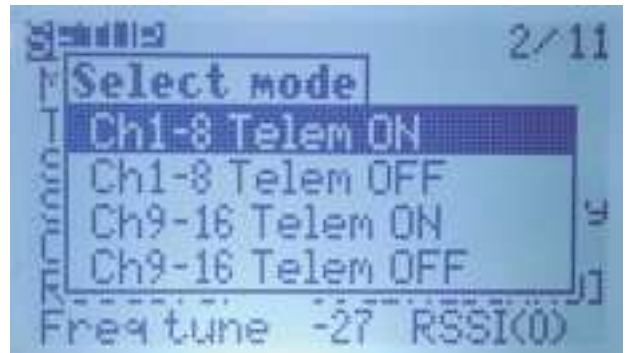

▲ 5. Select Ch1-8 Telem ON (default) or your own preference. Short press the right menu button to confirm Bind mode.

6. Receiver and Remote Control should be both in Bind mode and automatically discover each other. If not successful, please try again.

ELRS binding and firmware update

There's two methods to bind:
Custom Binding Phrase and Traditional.

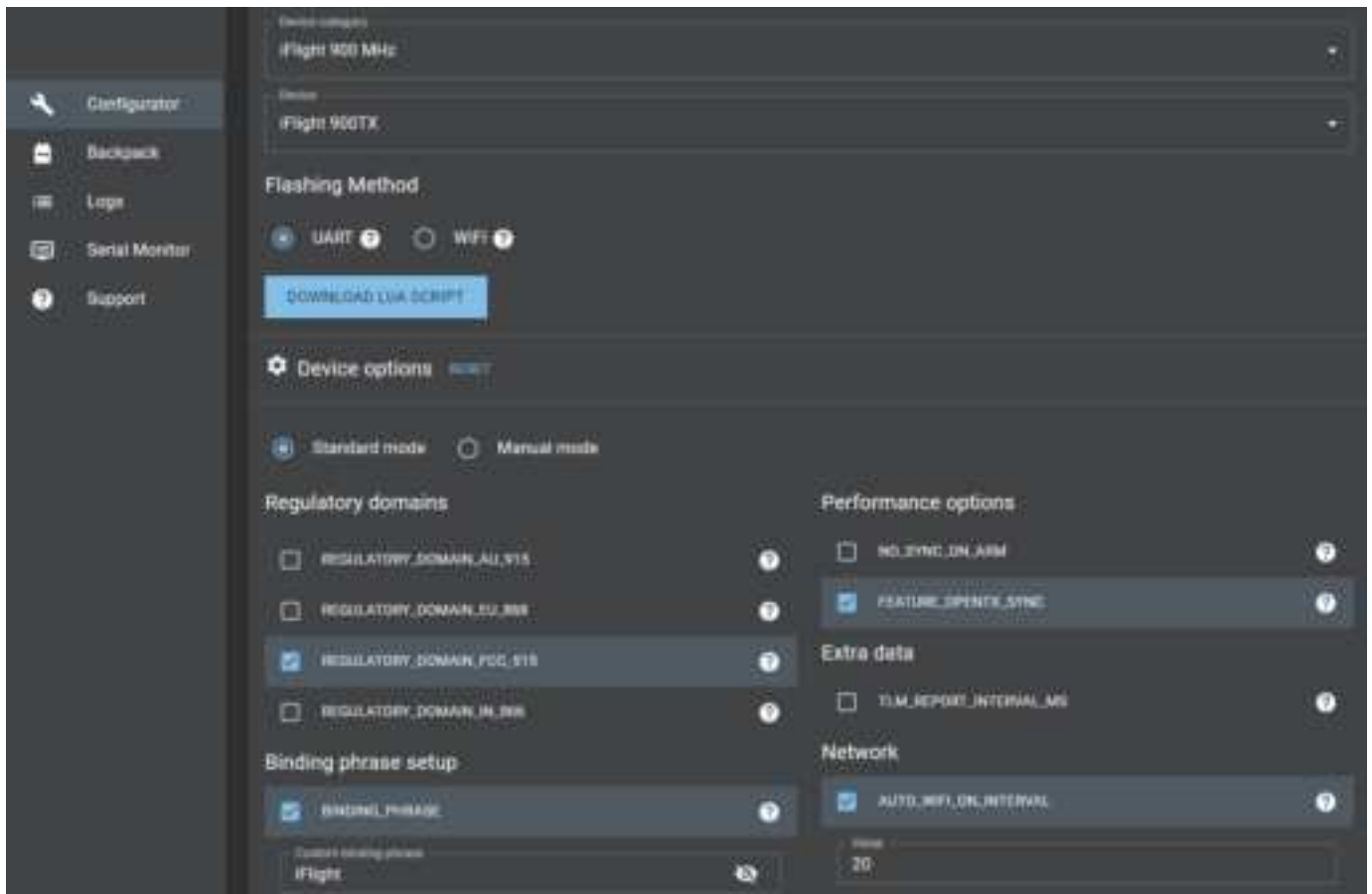

1. Binding with Custom Binding Phrase

When flashing the latest ELRS firmware for Receiver and Transmitter, just set a unique custom binding phrase to automatically bind all your hardware. Do not set a too simple binding phrase, otherwise other pilot's devices with the same binding phrase might link up as well.



For more specific information please refer to the ELRS quick start tutorial on the official website.

2.Traditional Binding Procedure

Example: iFlight ELRS 900MHz receiver



- ▲ 1. Once you power on the radio, hold the left menu button to the right to enter the MODESEL page.

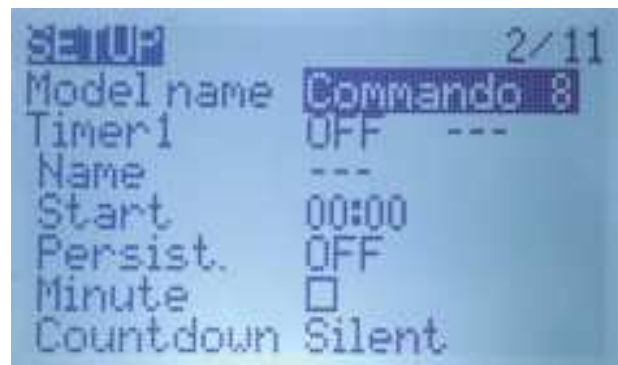

- ▲ 2. Push the right menu button to the right to go to the next page SETUP (2/12)



- ▲ 3. Scroll down to External RF and select CRSF/ELRS.



- ▲ 4. Select the ExpressLRS LUA script (latest version installed). Press the right 5-Axis Button to enter.



- ▲ 5. Scroll down to Bind, press the right 5-Axis button to enter. BIND mode active.



- ▲ 6. Binding screen appears. The blue LED on the receiver will turn to solid blue. Bind was successful.

Caution:

1. Be quick with this process and set the receiver in binding mode first.
2. After the binding process is completed, it's recommended to re-power receiver and transmitter.
3. The distance of receiver and transmitter should be more than 1m during the process.
4. The receiver firmware version should be consistent with the transmitter firmware version. If you can't bind your hardware, please try to update to the latest firmware.
5. If you can't bind your equipment, please try to reboot and several times if necessary.

VII. USB Functionality

1. Wired Simulator Mode

1. Power on the radio.
2. Connect the Type-C cable to the remote control and your computer.
3. Plug in the Type-C cable, selection screen appears,USB mode active.
4. Select the USB Joystick (HID) for Simulator mode.
5. Unplug the Type-C cable to exit Simulator mode.

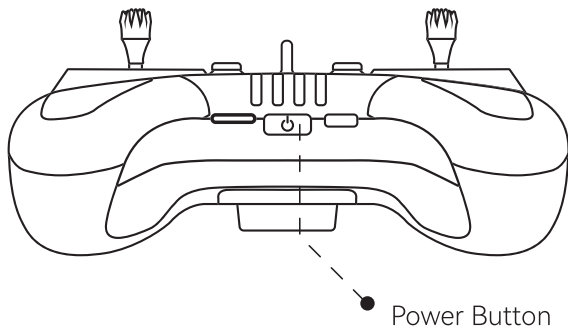

2. SD-Card mode

1. Power on the radio.
2. Connect the Type-C cable to the remote control and your computer.
3. Plug in the Type-C cable, selection screen appears,USB mode active.
4. Select the USB Storage (SD) for Storage mode.
5. Unplug the Type-C cable to exit Simulator mode.

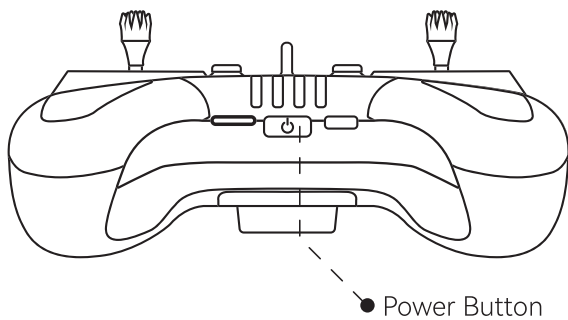

3. BOOT Menu and DFU Mode

Boot menu: First disconnect the USB cable. Hold down the Boot button then push and hold the Power button. Firmware can be flashed through the menu from the SD card.

DFU mode: First connect the USB cable to your computer and radio. Hold down the Boot button then push and hold the Power button. Screen stays dark, LEDs run from left to right. Firmware can be flashed through your computer.

VIII. Gimbal Mode and Calibration

1. Example: Mode1 to Mode2 Throttle

- Loosen the centering screw on your left hand gimbal until the stick centers itself.
- Adjust the left hand gimbal resistance screw to your preference.
- Tighten the right hand centering screw to lock self centering.
- Adjust the right hand gimbal resistance screw to your preference.
- Press and hold the left 5-Axis button (SYS) to enter the menu. Use the right 5-Axis button and push to the right (next Page) to Page3/7 RADIO SETUP and switch to MODE1.

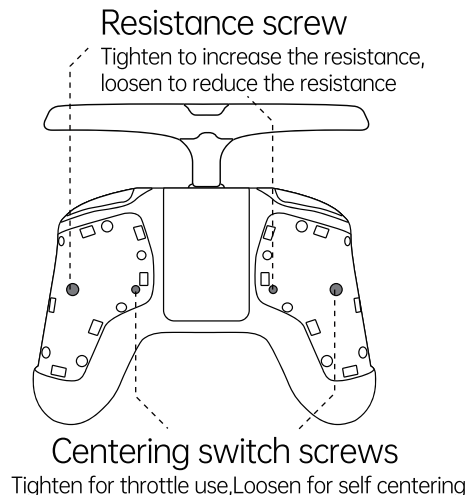

2. The default MODE for the Commando8 is MODE2 (Left Stick Throttle)

- 3. Press and hold the left 5-Axis button (SYS) to enter the menu. Use the right 5-Axis button and push to the right (next Page) to Page6/7 CALIBRATION. Start to calibrate your sticks.



▲ 1. Calibration.



▲ 2. Set the gimbal sticks to the midpoint and press the right button (Enter) for the next step.

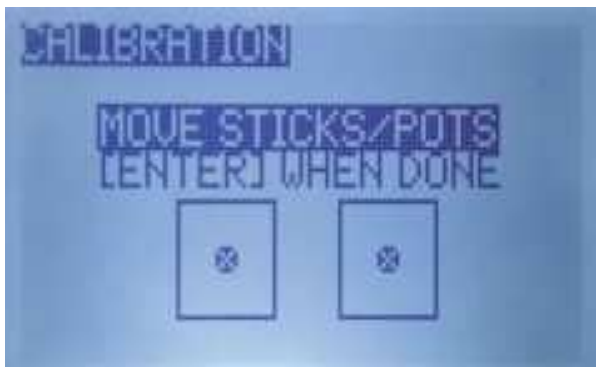

▲ 3. Gently move the sticks to their furthest positions several times and press the right button (Enter) when finished.

IX. First Boot Prompt

Before entering the main interface after powering on the radio, the system will do a self check. If there is an error, please follow the on-screen message or press any button to skip.



- ▲ Throttle is not at its lowest position.
Please move the throttle stick all the way down.



- ▲ One or several switches are not at the default position.



- ▲ The Version of your SD-card files do not match the version of your firmware.

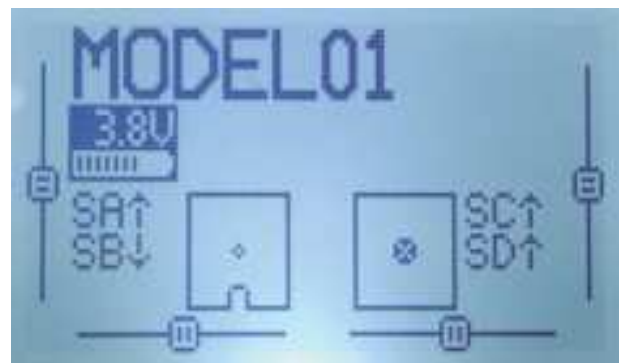

- ▲ Main Interface. Use the right 5-Axis button (PAGE) left or right to switch between different screen contents.

X. Model Setup and Selection

After booting into the main interface, push the right 5-Axis button to the right (MENU) to enter the system menu. First page MODELSEL.



- ▲ Move to a free entry then press and hold the right 5-Axis button (Enter).
To create a model press enter again.

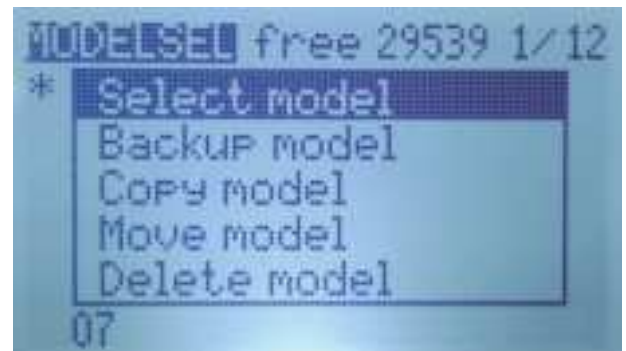

- ▲ Move to a model you have set up then press and hold the right 5-Axis button (Enter).
To use this model press Enter again at Select model.

The iFlight Commando8 Radio Transmitter has a pre-installed factory setup and is ready to use after successfully binding a model. Creating a new model will require to setup the correct parameters for it. We suggest using the iFlight factory setup.

XI. Product Specifications

Weight	315g±10
Size	154*765*72mm
Frequency	857-928MHz / 2.400GHz-2.480GHz
Output Power	CC2500: 100mW ELRS 2.4GHz: 10-500mW ELRS 915MHz: 100-1000mW
Transmit Module	CC2500 / ELRS 2.4GHz / ELRS 915MHz
Supported Protocols	S-FHSS / D16 / D8 / ELRS
Firmware	Edge TX
Channels	Up to 8 channels (4 gimbals+4 switches)
Gimbal	High precision digital hall sensor gimbals
Operation Temperature	0° to 40°C (32° to 104°F)
Charging Temperature	5° to 40°C (41° to 104°F)
Battery Type	Lithium-ion battery
Batteries	2x 18650 2000mAh
Voltage	3.6V
Capacity	14.4 Wh



Warning

The Commando8 is pre-installed with stable firmware. Unless you are experienced and confident in updating the system firmware, incorrect updates may lead to radio inoperable. For main control firmware and ELRS transmitter firmware update, please refer to the usage video.

WiFi upgrade



Hold down System Settings to go to the TOOLS screen, move the cursor to the ExpressLRS option, and hold down Enter to go to the next option



Select WiFi Connectivity from the Lua script, then Select Enable WiFi. Press OK again to activate WiFi on the Tx module. Connect to the WiFi access point created by the module with the name ExpressLRS TXModule and password expresslrs

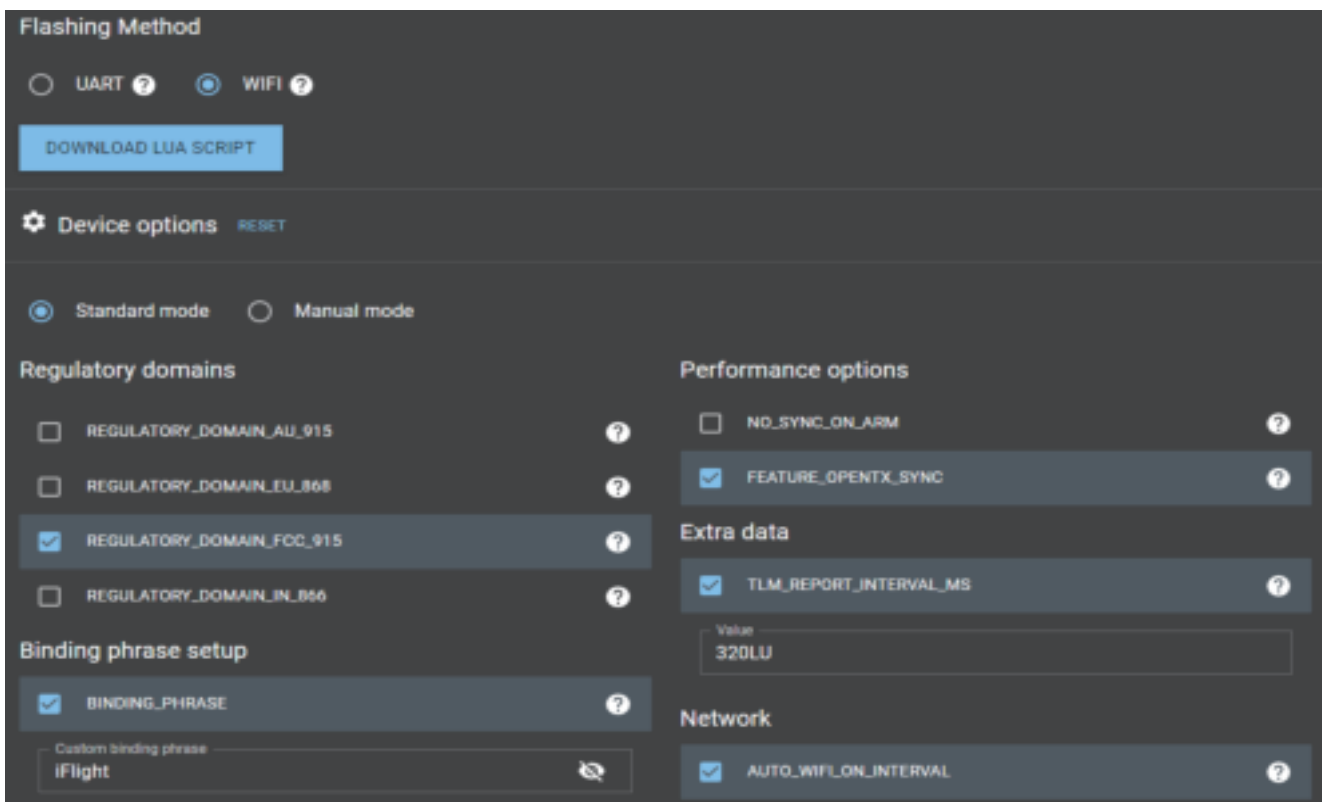

When arriving at Expresslrs ground station, select the corresponding setting option, change the brush method to WIFI, select the corresponding serial port, click Create and brush to complete the brush. For details, please refer to the ExpressLRS website's Quick Start tutorial or the iFlight Light Release Account video tutorial.

FCC Statement

This equipment has been tested and found to comply with the limits for a Class B digital device, pursuant to part 15 of the FCC Rules. These limits are designed to provide reasonable protection against harmful interference in a residential installation. This equipment generates, uses and can radiate radio frequency energy and, if not installed and used in accordance with the instructions, may cause harmful interference to radio communications. However, there is no guarantee that interference will not occur in a particular installation. If this equipment does cause harmful interference to radio or television reception, which can be determined by turning the equipment off and on, the user is encouraged to try to correct the interference by one or more of the following measures:

- Reorient or relocate the receiving antenna.
- Increase the separation between the equipment and receiver.
- Connect the equipment into an outlet on a circuit different from that to which the receiver is connected.
- Consult the dealer or an experienced radio/TV technician for help.

Caution: Any changes or modifications to this device not explicitly approved by manufacturer could void your authority to operate this equipment.

This device complies with part 15 of the FCC Rules. Operation is subject to the following two conditions: (1) This device may not cause harmful interference, and (2) this device must accept any interference received, including interference that may cause undesired operation.

RF Exposure Information

The device has been evaluated to meet general RF exposure requirement. The device can be used in portable exposure condition without restriction.



www.iflight-rc.com



Follow iFlight on social media to get updates

HuiZhou iFlight Intelligent Technology Ltd.
Floor5 NO.3, Shenghua Road,Zhongkai Hi-tech Area,Huizhou,CN
0752-3866695