



REFERENCE:
G13-B

COUNTRY OF ORIGIN: PRC

TECHNICAL SPECIFICATIONS:

- 13pin 12V
- black color
- carton dimension 500x230x270 mm
- 100 pcs in bulk box
- plug weight: 135g

Warning and installation instructions:

- Use in accordance to the purpose.
- Install only in specialized workshops or professional services.
- The connector is used to connect the pneumatic brake system of the vehicle with the trailer system.



www.truck-kamar.pl

PHOTO:



SOCKET 13 PIN

EAC

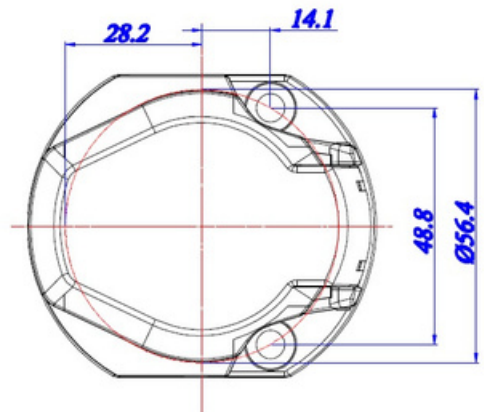
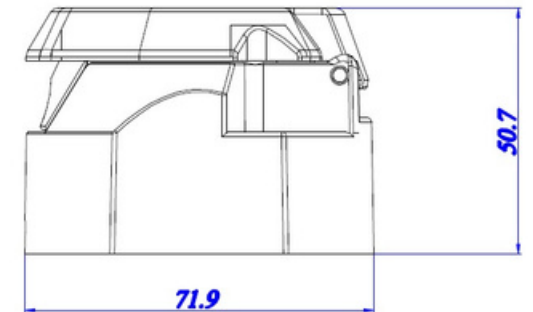
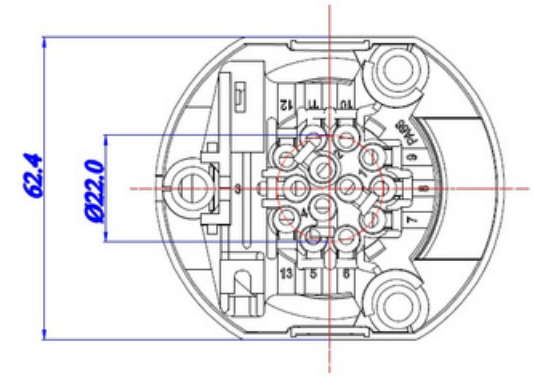

MARK	FUNCTION
1	Left Turn Signal
2	Rear fog lamps
3	Ground connected
4	Right Turn Signal
5	Tail lamps, right side
6	Stop lamps
7	Tail lamps left side
8	Reversing lamps
9	+12V permanent
10	+12V via ignition lock
11	Ground (-) for pin 10
12	Reserved for future allocation
13	Ground (-) for pin 9