



REFERENCE:
E0002-A

COUNTRY OF ORIGIN: PRC

TECHNICAL SPECIFICATIONS:

- 3pin 12V,
- plastic housing(PA6),
- brass pins,
- carton dimension 450x240x300 mm,
- 200 pcs in bulk box,
- box weight: 9kg

Warning and installation instructions:

- Use in accordance to the purpose.
- Install only in specialized workshops or professional services.
- The connector is used to connect the pneumatic brake system of the vehicle with the trailer system.



www.truck-kamar.pl

PHOTO:

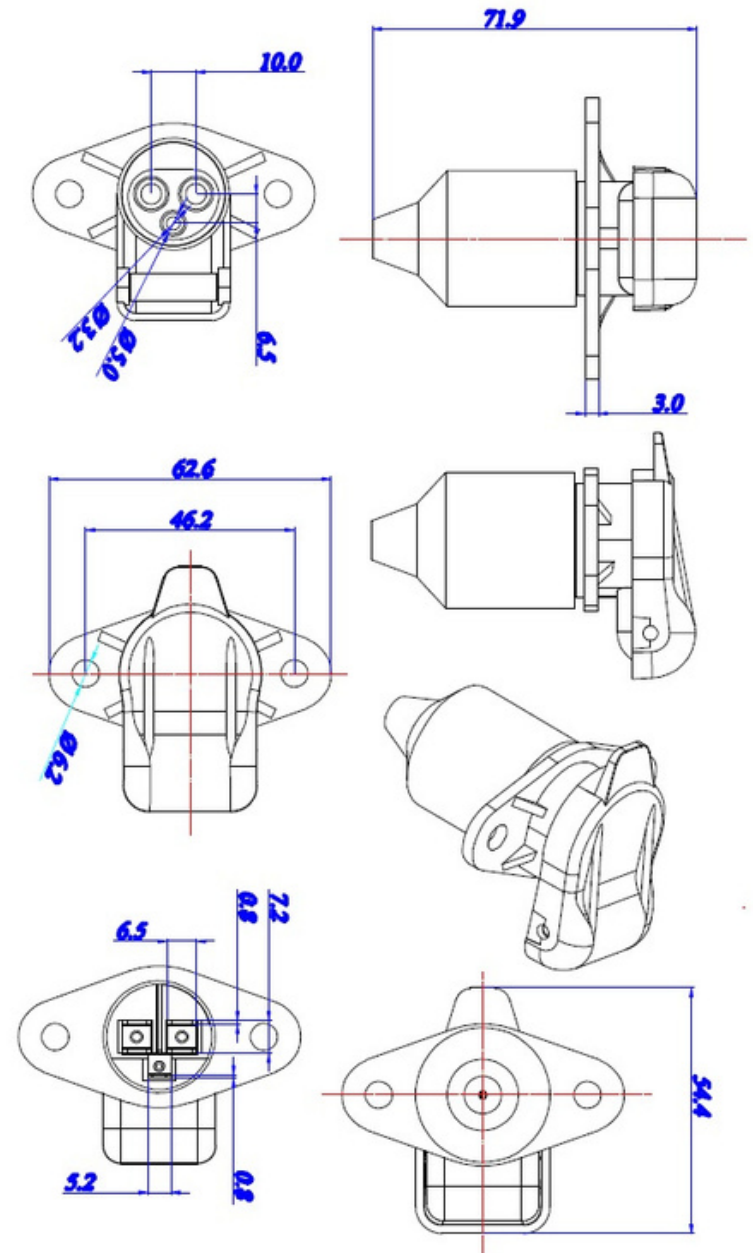

3 PIN PLASTIC SOCKET

EAC