

Laser Sensor Catalogue

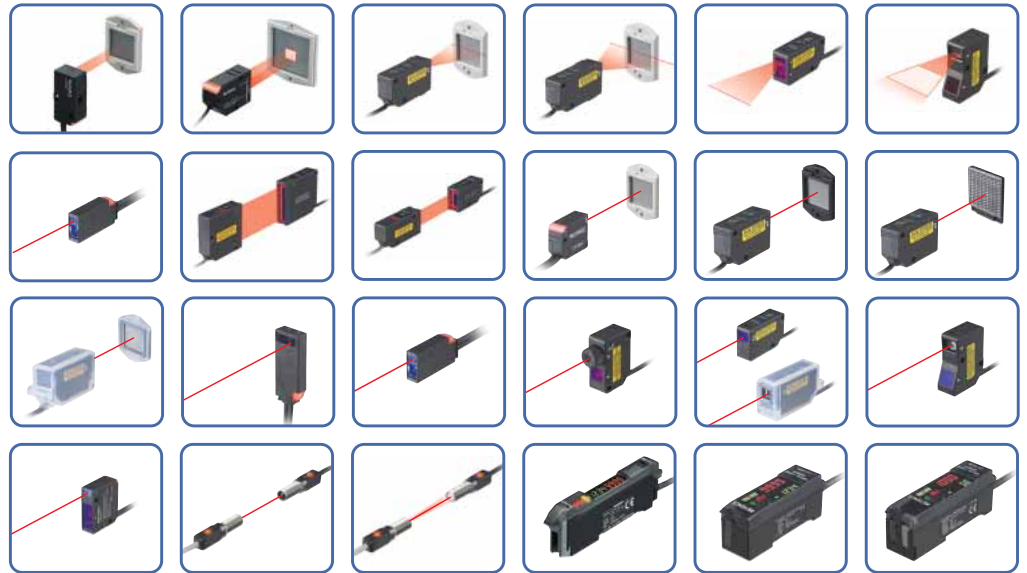

Choose from the largest selection of laser sensors in the industry!

New laser sensors [➔ P. 6](#)



Product composition

The LV Series are digital laser sensors consisting of both a sensor head and an amplifier.

Please note that the supported amplifier unit depends on the sensor head.

LV-S Series

- Compact size
- Transparent object detection (available)
- Zero datum function (available)

Sensor head

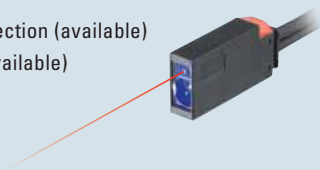

Amplifier



LV-11SB
LV-12SB

LV-H Series

Reflective/Retro-Reflective

- High-power
- Waterproof (available)

Sensor head

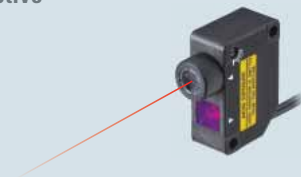

Amplifier



LV-21A
LV-22A
LV-20A

LV-H Series

Thru-beam

- 10 mm/30 mm area
- Analogue output

Sensor head



Amplifier



LV-51M
LV-52

Laser sensor features

Visible beam allows for easy installation

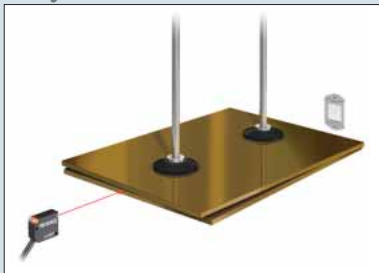

Stable target detection from remote location

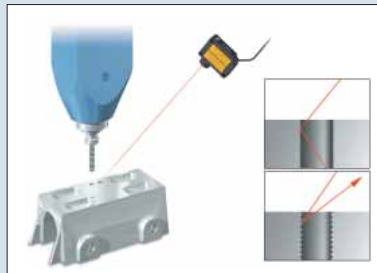

Small beam spot ensures high precision

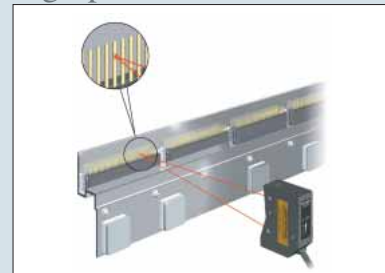



Product selection guide

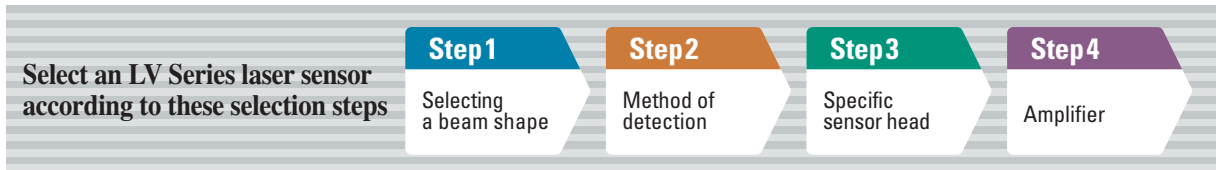

Step 1 Selecting a beam shape

Select a laser sensor head, either an area beam or small beam spot, according to the target that is to be detected.

Area Beam

The shape of the laser beam emitted on the target forms a line.

Effective for wide detection ranges, such as when the target's position varies as it passes through the beam.

Type	Area Beam		
	Reflective	Retro-Reflective	Thrubeam
Detecting image			
Page		➔ P.4	

Small Beam Spot

The shape of the laser beam emitted on the work piece forms a small spot.

Effective for highly precise detection of minute targets.

Type	Small Beam Spot		
	Reflective	Retro-Reflective	Thrubeam
Detecting image			
Page		➔ P.5	

Step 2

Method of detection

Select either a reflective, retro-reflective, or thru-beam sensor based on the application.

▶ If area beam was selected in Step 1

Area Beam

Retro-Reflective [▶ P.6](#)

Highly precise target detection with easy installation

Area laser



LV-S62

Long-distance transparent object detection

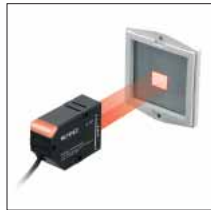

LV-S63

Long distance



LV-H64

Wide



LV-H65

Reflective [▶ P.9](#)

Small size and highly flexible installation

Long distance



LV-H42/H41*

Definite reflective

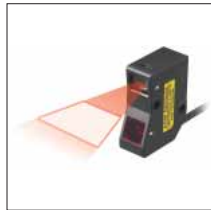

LV-H47

* LV-H41 is a class1 infrared laser model.

Thru-beam [▶ P.10](#)

Unaffected by the target's colour or shape

10mm width

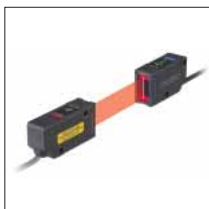

LV-H100

30mm width



LV-H300

High-power 10mm width

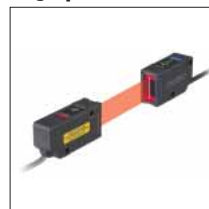

LV-H110

 **Ask the Expert**
Call us for Details on
the LV Series

▶ If small beam spot was selected in Step 1

Small Beam Spot

Retro-Reflective P.12

Highly precise target detection with easy installation

Small

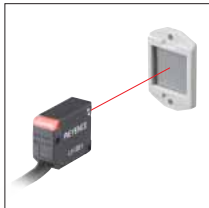

LV-S61

Standard



LV-H62

Long distance
(up to 50 m)



LV-H67

Waterproof: IP67

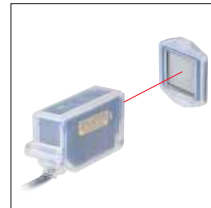

LV-H62F

Reflective P.14

Small size and highly flexible installation

Small
(side view)



LV-S41 (S41L)

Adjustable beam spot

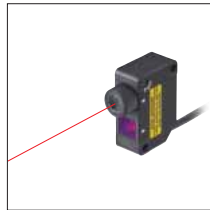

LV-H32

Coaxial structure
(waterproof: IP67)

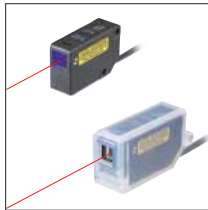

LV-H35 (H35F)

Ultra-small beam spot
(diameter: 50 µm)

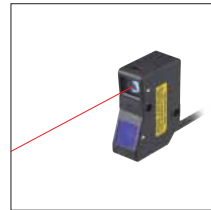

LV-H37

Adjustable distance setting

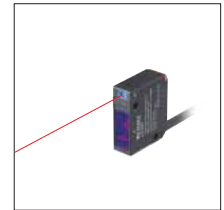

LV-S31

Thrubeam P.16

Unaffected by the target's colour or shape

Small: M6

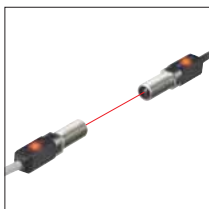

LV-S71

Small: M6 (with slit)



LV-S72

Step 3

Selecting a specific sensor head

Select a sensor head tailored to your application.

▶ If area beam retro-reflective was selected in Step 2

Area Beam Retro-Reflective

Type	Shape (mm)	Detection distance*	Area width (mm)	Model	Supported amplifier	Dimensions diagram
Area Laser		ULTRA : 10m (5m) *1 SUPER : 8m (3.5m) TURBO : 5m (2m) FINE : 2.5m (0.7m)	Area spot: approx. 10 mm Small beam spot: approx. 2 mm (up to 500 m distance)	LV-S62	LV-11SB LV-12SB	
Long-distance transparent object detection		ULTRA : 30m SUPER : 25m TURBO : 15m FINE : 8m	Approx. 8 x 12 mm (up to 3.5 m distance)	LV-S63		
Long-distance area		SUPER : 400~1200mm (600~1500mm) *2 TURBO : 200~850mm (300~1000mm) FINE : 100~500mm (100~700mm)	Approx. 40 (up to 300 mm distance)	LV-H64	LV-21A LV-22A LV-20A	
Wide area		SUPER : 100~200mm (150~350mm) *2 TURBO : 10~150mm (10~250mm) FINE : 100mm (150mm)	Approx. 50 (up to 100 mm distance)	LV-H65		

All models support the P.R.O. function. The polarising filter reduces direct reflected light from a mirrored-surface target.

*1 Numbers not enclosed in parentheses are the detecting distance for area spot. Numbers enclosed in parentheses are the detecting distance for small beam spot.

*2 Numbers not enclosed parentheses are the detecting distance when an accessory reflector is used. Numbers enclosed in parentheses are the detecting distance when OP-51428 (sold separately) is used.

Product features

Area Laser

LV-S62

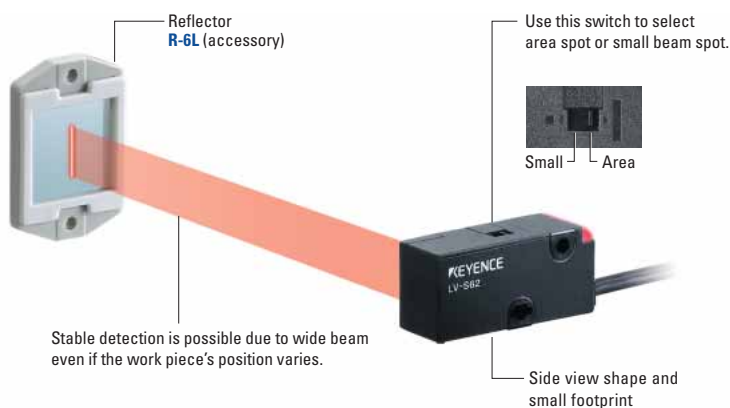

LV-S62 is perfect for transparent object detection.

(Note) We recommend that, when LV-S62 is used for glass detection, the detecting distance be set to 1 m or less.

Using all of the mounting brackets allows you to adjust the optical axis right, left, up, and down.

When installing the rear mounting bracket (sold separately)

OP-84350

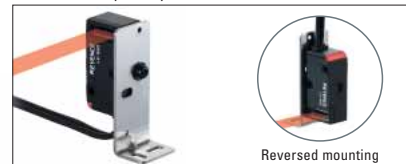

When installing the rear mounting bracket (sold separately)

OP-84349



When installing the rear mounting bracket (sold separately)

OP-84351



Be sure to use the dedicated mounting brackets because optical axis adjustment is required.



Long-Distance Transparent Object Detection

LV-S63

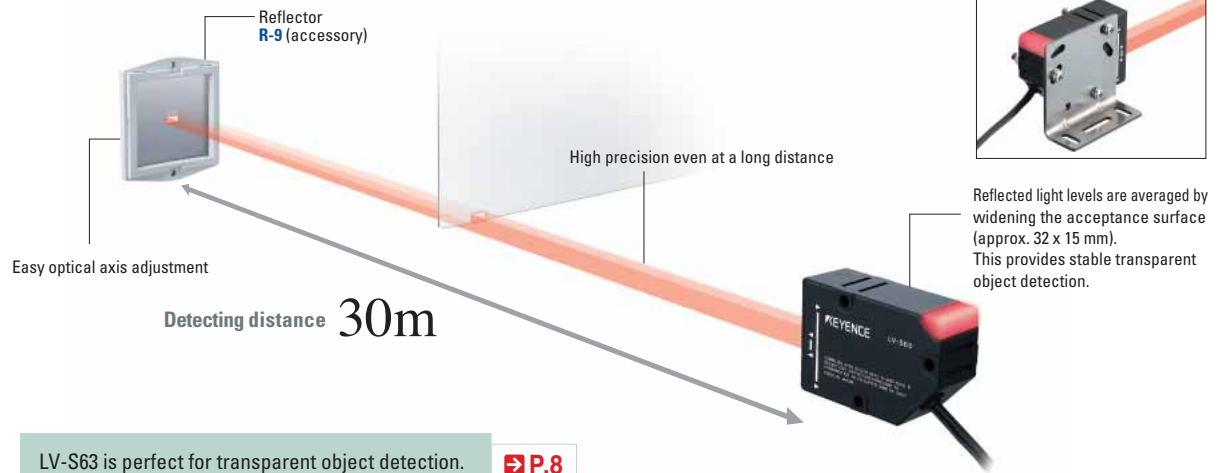

LV-S63 is perfect for transparent object detection.



(Note) We recommend that, when LV-S63 is used for glass detection, the detecting distance be set to 3.5 m or less.

Long-Distance Area

LV-H64

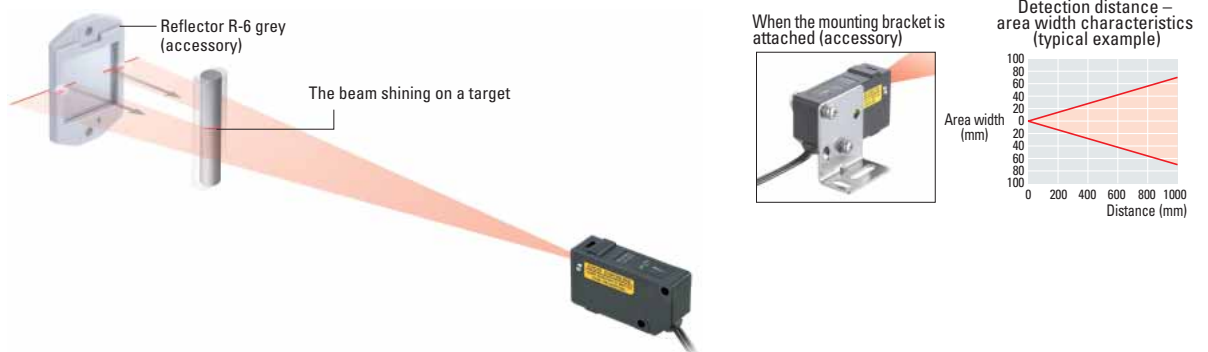

Wide Area

LV-H65

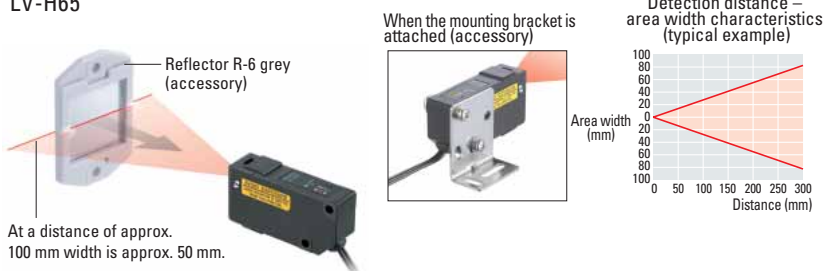

Options for LV-H64 and H65

Name	Reflective tape (sold separately)
Model	OP-51428
Shape	

STEP 1

STEP 2

STEP 3

STEP 4

SPECIFICATIONS

DIMENSIONS

What sets the LV-S62/LV-S63 apart from conventional sensors for transparent object detection?

Beam Shape

Area beams are excellent for detecting targets with gaps.

Unlike small beam spots, area beams are less affected by vibrating targets or backgrounds.

LV-S63 also spreads the spot's depth (8 x 12 mm) to provide more stability.

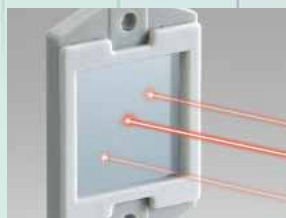

Small spot
Large light quantity variation if position shifts



Area beam
Small light quantity variation even if position shifts

Laser Beam

Can stably detect vibrating/inclining transparent targets

Due to the characteristics of lasers, the slightest incline of a transparent target can cause light diffraction resulting in unstable detection. The newly-developed laser drive circuit found in the LV-S62 and LV-S63 compensates for this phenomenon.

High-frequency superimposition drive circuit

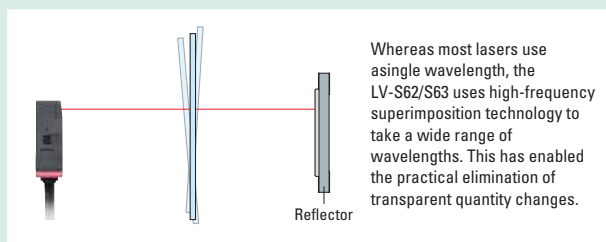

Amplifier

The amplifier cancels light quantity variation.

The zero datum function always monitors the received light quantity when there is no transparent object and keeps the displayed value at 0 (light quantity variation cancellation). If a transparent object is input, the function displays the difference. This makes it very easy for the LV series amplifier to stably detect transparent targets.

(Patent pending)

World's first zero datum function





Step 3

Selecting a specific sensor head

Select a sensor head tailored to your application.

▶ If area beam reflective was selected in Step 2

Area Beam Reflective

Type	Shape (mm)	Detecting distance (mm)	Area width (mm)	Model	Connectable amplifier	Dimensional outline drawing
Long Distance		SUPER : 1000 TURBO : 500 FINE : 250	Approx. 48x0.4 (at 200 mm distance)	LV-H42	LV-21A LV-22A LV-20A	P.34
Definite reflective		55-85 * Common in all power modes	Approx. 21x0.7 (at 70 mm distance)	LV-H47	P.19	P.33

Product features

Long Distance

LV-H42

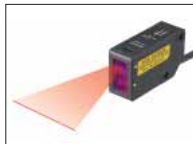

When the mounting bracket is attached (accessory)



Slit (accessory)



An area width can be selected.

Lens (sold separately)



The area becomes thicker.

Definite Reflective

LV-H47



When the mounting bracket is attached (accessory)



Slit (accessory)



An area width can be selected.

Lens (sold separately)



The area becomes thicker.

Characteristics figure

Characteristics of received light quantity and distance (typical example)

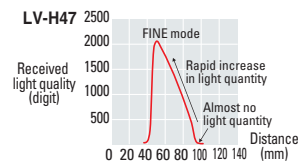

Characteristics of detecting distance and area width (typical example)

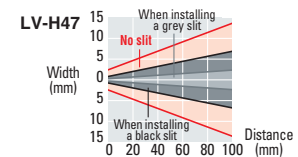
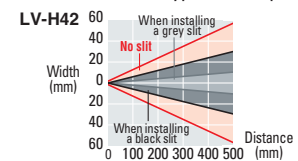



Ask the Expert
Call us for Details on
the LV Series

Step 3

Selecting a specific sensor head

Select a sensor head tailored to your application.

▶ If area spot thru-beam was selected in Step 2

Area Spot Thru-beam

Type	Detecting width (mm)	Shape (mm)	Detecting distance (mm)	Area width (mm)	Model	Connectable amplifier	Dimensional outline drawing
Standard	10		2000 * Common in all power modes	Approx. 12	LV-H100	LV-51M LV-52 P.19	P.37
	30			Approx. 32	LV-H300		
High powered	10			Approx. 12	LV-H110		

Product features

Standard /High Power (10 mm wide)

LV-H100/110



When the mounting bracket is attached (accessory)



When the mounting bracket is attached (accessory)



Example using the LV-H110

LV-H110 is a sensitivity-improved type of LV-H100. LV-H110 detects only workpieces that completely interrupt light.

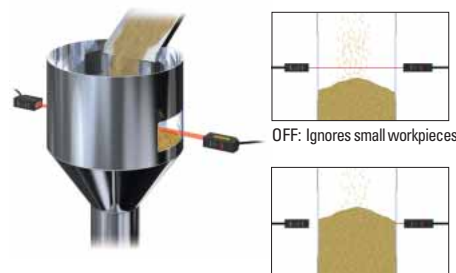

Standard (30 mm wide)

LV-H300



When the mounting bracket is attached (accessory)



When the mounting bracket is attached (accessory)



Easy optical axis adjustment via visible beam

You can clearly see beam because a light diffuser sheet is inserted into the end of the receiver. This makes optical axis adjustment extremely easy.

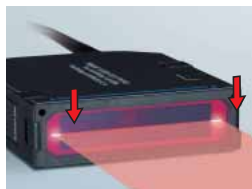

Mounting brackets provide beam position adjustment.

Two types of mounting brackets are available: Brackets for mounting vertical and brackets for mounting horizontal. Be sure to use the dedicated mounting bracket.



Application

Area spot

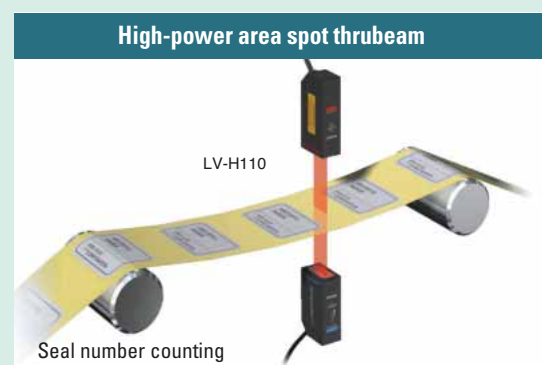
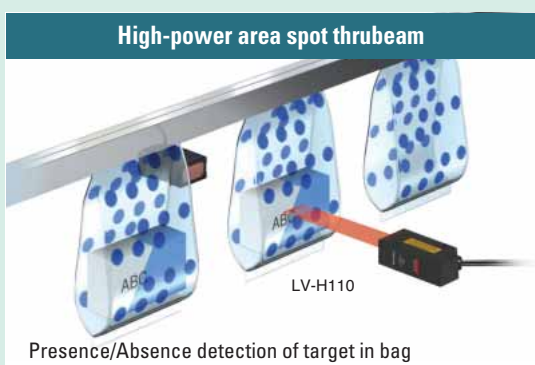
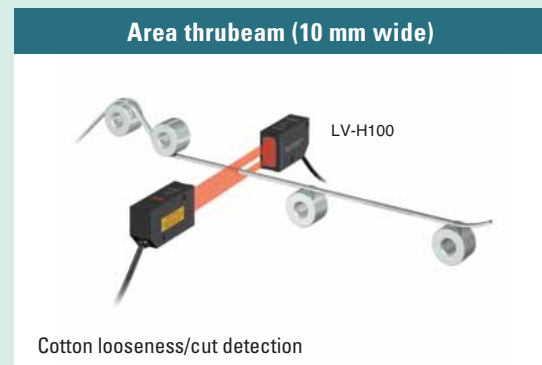
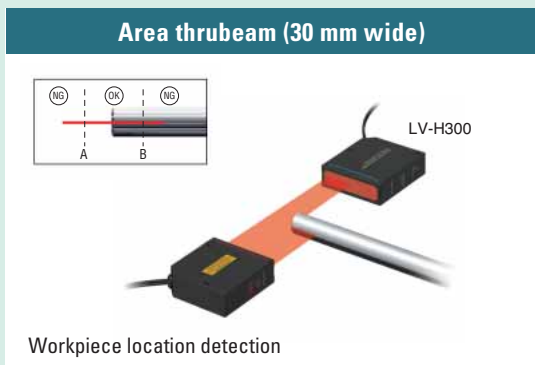
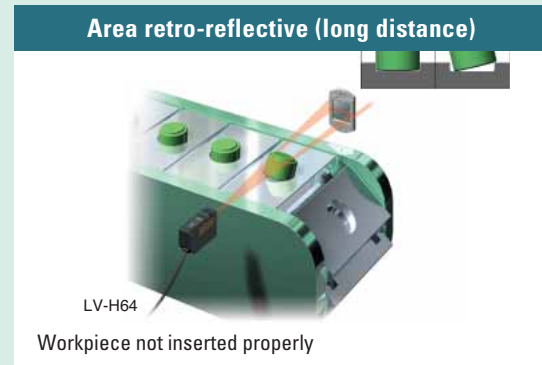
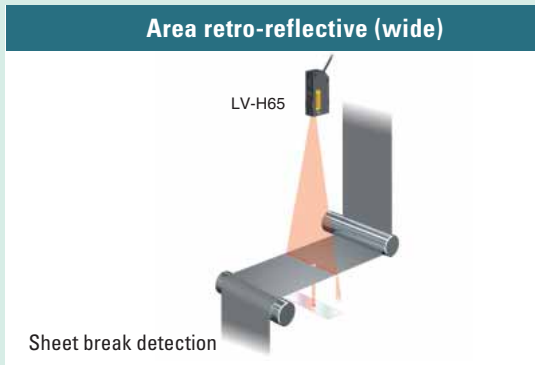
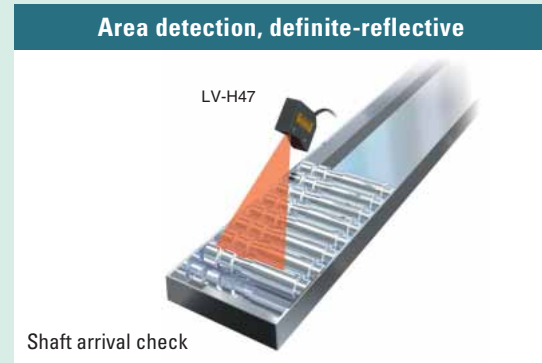
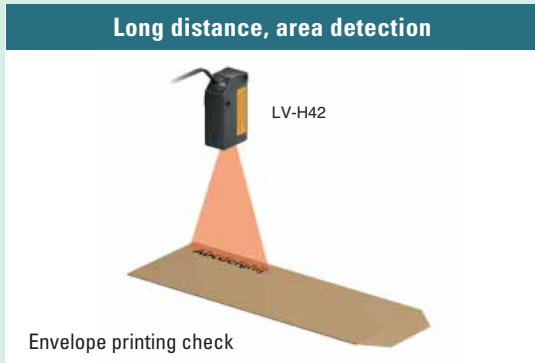

STEP 1

STEP 2

STEP 3

STEP 4

SPECIFICATIONS

DIMENSIONS

Step 3

Selecting a specific sensor head

Select a sensor head tailored to your application.

▶ If small beam spot retro-reflective was selected in Step 2

Small Beam Spot Retro-Reflective

Type	Shape (mm)	Detection distance (m)	Spot diameter (mm)	Model	Connectable amplifier	Dimensional outline drawing
Small		ULTRA : 2 SUPER : 1.5 TURBO : 1 FINE : 0.75 HSP : 0.5	Approx. ϕ 2.5 (Up to 0.5m distance)	LV-S61	LV-11SB LV-12SB ▶ P.18	▶ P.29
Standard		SUPER : 7 TURBO : 5 FINE : 2	Approx. ϕ 1.5 (Up to 1 m distance)	LV-H62		▶ P.32
Long distance (up to 50 m)		SUPER : 30* TURBO : 30 FINE : 20 * Use OP-42198: 50m	Approx. 50 x 15 (At 10 m distance)	LV-H67	LV-21A LV-22A LV-20A ▶ P.19	▶ P.32
Waterproof: IP67		SUPER : 5 TURBO : 3.5 FINE : 1.5	Approx. ϕ 2 (At 2 m distance)	LV-H62F		▶ P.32

*All models support the P.R.O. function. The polarizing filter reduces direct reflected light from a mirrored-surface work piece.

Difference from fibre sensor

Fibre sensor

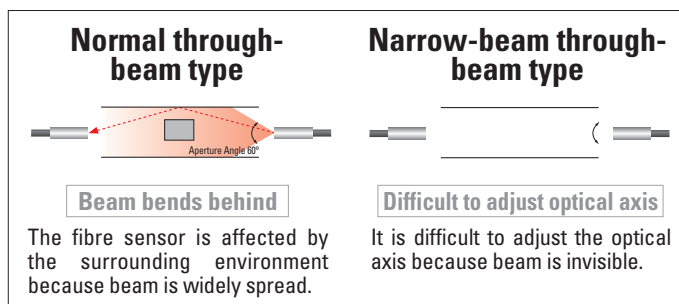

Laser sensor

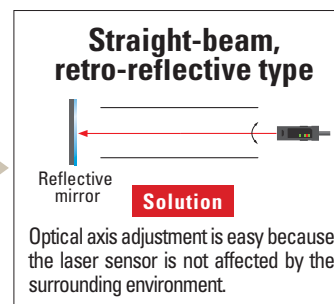

Characteristics figure

Characteristics of detecting distance and spot diameter (typical example)

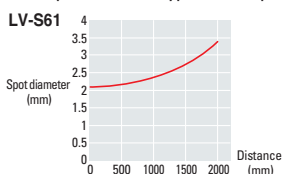

Characteristics of detecting distance and spot diameter (typical example)

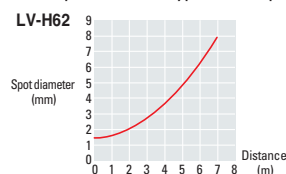



Product features and mounting brackets

Small

LV-S61

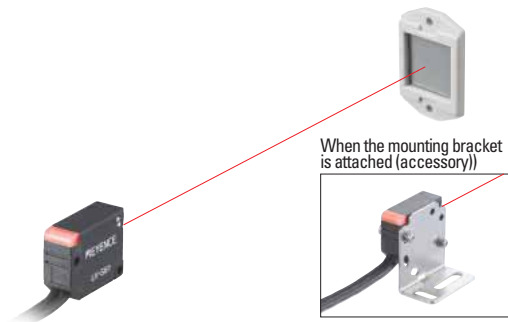

Long Distance (upto 50m)

LV-H67

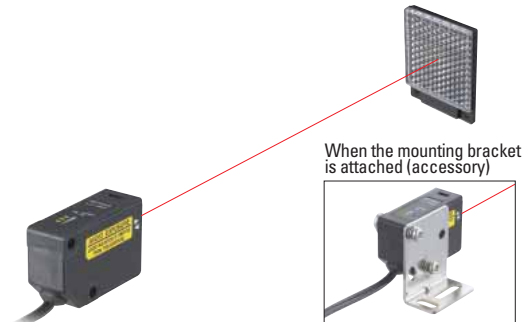

Standard

LV-H62

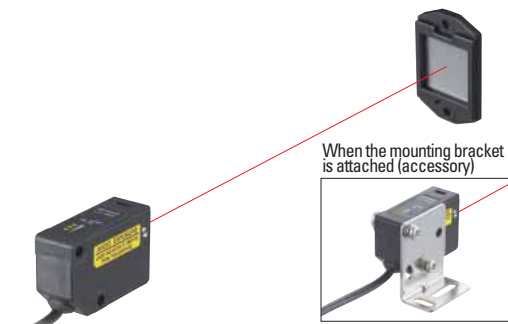

Waterproof: IP67

LV-H62F

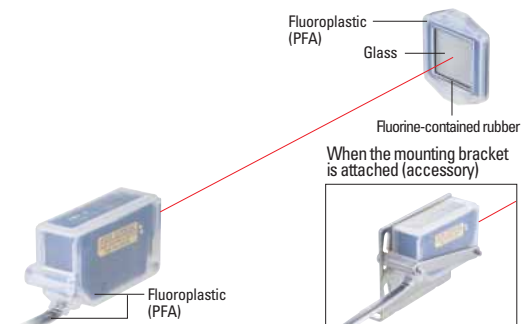

Reflector (accessory)

Type	Reflector				
Model	OP-51430 (R-6 grey)	R-6	R-7	OP-95388 (R-2)	R-8
Accessory model	LV-S61	LV-H62		LV-H67	LV-H62F
Shape					
Dimensions	➔ P.29	➔ P.32	➔ P.32	➔ P.33	➔ P.32

Reflector (option)

Type	Reflective tape	Reflector
Model	OP-42197	OP-42198
Supported model	LV-S61/H62	LV-H67
Shape		
Dimensions	—	➔ P.33

* The detecting distance remains unchanged even if the reflective tape is used.











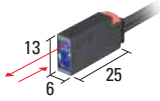

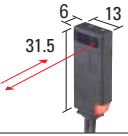

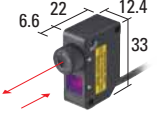
Step 3

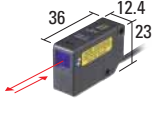
Selecting a specific sensor head

Select a sensor head tailored to your application.

▶ If small beam spot reflective type is selected in Step 2

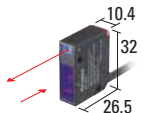
Small Beam Spot Reflective

Type	Shape (mm)	Detection distance (mm)	Spot diameter (mm)	Model	Connectable amplifier	Dimensional outline drawing
Small		<ul style="list-style-type: none"> ULTRA : 500 SUPER : 400 TURBO : 300 FINE : 200 HSP : 150 	 Approx. $\phi 1.2$ (Up to 500 mm distance)	LV-S41	LV-11SB LV-12SB ▶ P.18	▶ P.29
Small side view		<ul style="list-style-type: none"> ULTRA : 400 SUPER : 320 TURBO : 240 FINE : 160 HSP : 120 	 Approx. $\phi 1.2$ (Up to 400 mm distance)	LV-S41L		
Adjustable beam spot		<ul style="list-style-type: none"> SUPER : 1000 TURBO : 500 FINE : 250 	 $\phi 0.8$ or less (Up to 300 mm distance)	LV-H32	LV-21A LV-22A LV-20A ▶ P.19	▶ P.33
Coaxial structure		<ul style="list-style-type: none"> SUPER : 600 TURBO : 300 FINE : 150 	 Approx. $\phi 2$ (Up to 600 mm distance)	LV-H35		▶ P.32
Waterproof: IP67		<ul style="list-style-type: none"> SUPER : 450 TURBO : 200 FINE : 100 	 Approx. $\phi 2$ (Up to 450 mm distance)	LV-H35F		▶ P.32
Ultra-small beam spot		<ul style="list-style-type: none"> 70±15 * Common in all power modes	 Approx. 50 μm (At 70 mm distance)	LV-H37		▶ P.33
Small adjustable distance setting		Adjustment range*: 50 to 200 * Range in which the reference distance can be adjusted without reference to the response time	 Approx. $\phi 2$ (Up to 200mm distance)	LV-S31	LV-11SB LV-12SB ▶ P.18	▶ P.28

Characteristics figure

Characteristics of detecting distance and minimum spot diameter (typical example)

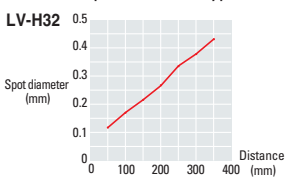

Characteristics of setting distance and spot diameter (typical example)

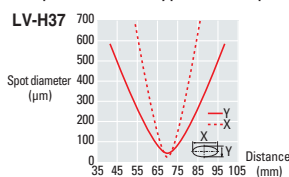



Product features and mounting brackets

Small

LV-S41 (S41L)

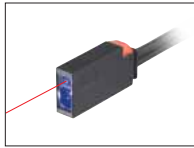

When the mounting bracket is attached

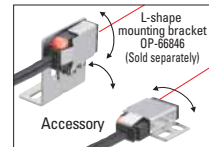

Small Side-View

LV-S41L

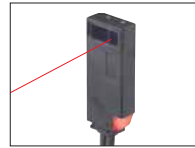

When the mounting bracket is attached

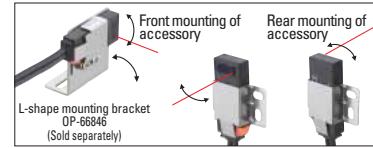

Adjustable Beam Spot

LV-H32



When the mounting bracket is attached (accessory)



Adjustable by hand

Spot adjustment can be easily made by turning the focus ring by hand.



Also lockable

It is safe because of the lens position lock feature.

Coaxial Structure

LV-H35



When the mounting bracket is attached (accessory)



Coaxial structure

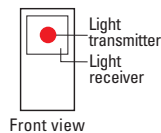

Example

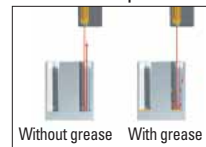

With the coaxial structure, the LV-H35 can receive reflected light even from a small gap.

Waterproof: IP67

LV-H35F



When the mounting bracket is attached (accessory)



Material

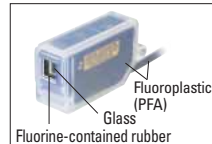

Ultra-small Beam Spot (50µm)

LV-H37



When the mounting bracket is attached (accessory)

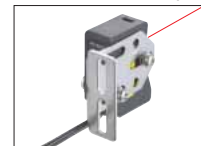

The supplied magnifying glass enables users to check the beam spot position.



Small Adjustable Distance Setting

LV-S31

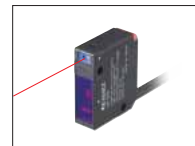

When the mounting bracket is attached (accessory)





Ask the Expert
Call us for Details on
the LV Series

Step 3

Selecting a specific sensor head

Select a sensor head tailored to your application.

▶ If small beam spot thru-beam type is selected in Step 2

Small Beam Spot Thru-beam

Type	Shape (mm)	Detection distance (mm)	Spot diameter (mm)	Model	Connectable amplifier	Dimensional outline drawing
Small beam spot		500mm * in all power modes	Approx. $\phi 1.2$ (Up to 500 mm distance)	LV-S71	LV-11SB LV-12SB ▶ P.18	▶ P.30
Step differentiation		500mm * in all power modes	Approx. $\phi 6$ (At 500 mm distance)	LV-S72		

Product features

Small Beam Spot

LV-S71

Ultra-small **World's Smallest**
LV-S71 is the smallest red laser sensor in its class.



Operation indicator

Both the transmitter and receiver are equipped with the operation indicator.

Receiver

Standard mounting bracket (accessory)



Small type mounting bracket (option)

OP-66869



The optical axis can be adjusted from above.

Each symmetrical mounting bracket (two sets)

Step Differentiation

LV-S72

High-precision differentiation

The receiver side uses a slit with a width of 0.6 mm, allowing high-precision differentiation.

Receiver

Easy optical axis adjustment

Optical axis adjustment is easy because the spot diameter is approx. 6 mm at 500 mm ahead of the transmitter (large spot).

Transmitter

Side viewer attachment (option)

LV-F1

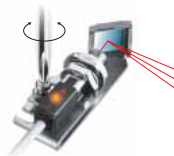

The optical axis can be adjusted from above.

(2 Brackets To 1 Set)

Application

Small beam spot

Small beam spot reflection (adjustable beam spot)

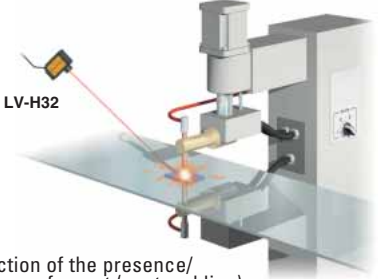

LV-H32

Detection of the presence/absence of a part (spot welding)

Small beam spot reflection (side view)

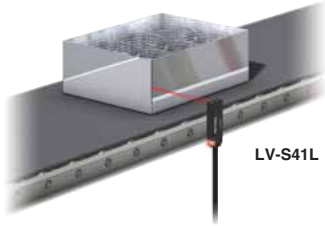

LV-S41L

Rack stop position detection

Small beam spot reflective (coaxial structure)

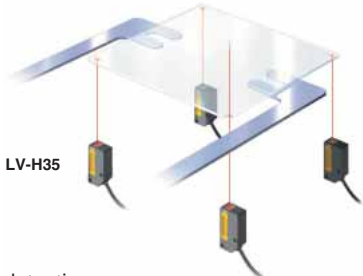

LV-H35

Glass detection

Small beam spot reflective (distance setting)

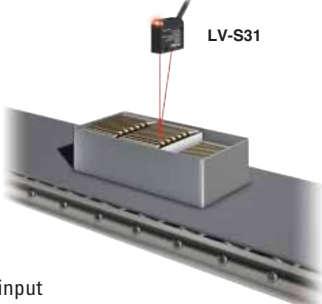

LV-S31

Counter input

Small beam spot retro-reflective (small)



LV-S61

Detection of work pieces remaining in the mold.

Small beam spot retro-reflective (long distance)

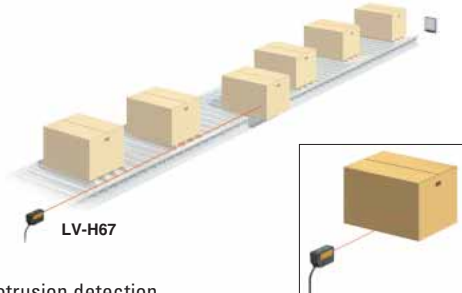

LV-H67

Protrusion detection

Small beam spot thru-beam (small, M6)

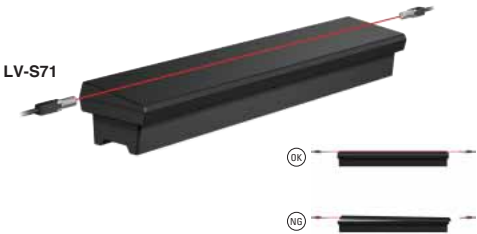

LV-S71

OK

NG

Floating cover detection

Small beam spot thru-beam (small, M6)

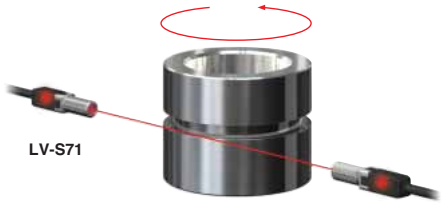

LV-S71

De-burr checking

STEP 1

STEP 2

STEP 3

STEP 4

SPECIFICATIONS

DIMENSIONS

Step 4



Selecting an amplifier

When using one amplifier, select the main unit. When using two or more amplifiers, select one main unit and one or more expansion units.

▶ If the LV-S series is selected in Step 3

LV-S Series

The main unit comes with an amplifier mounting bracket.
The expansion unit comes with an end unit.

Type	Shape (mm)	Number of ON/OFF outputs	External input*	Model		Dimensions
				NPN output	PNP output	
Main unit		2	1	LV-11SB	LV-11SBP	P.31
Expansion unit		2	1	LV-12SB	LV-12SBP	

* For external input, select "light emission stop", "tuning", "set value bank selection" or "received light quantity shift."
Up to 16 expansion units can be installed to one main unit.

Connectable sensor heads

Reflective	LV-S41, LV-S41L, LV-S31
Retro-Reflective	LV-S61, LV-S62, LV-S63
Thru-beam	LV-S71, LV-S72

Part names and features



The LV-S series comes with the world's first zero datum function.

Usually* the first digit of the digital display will drift when there is no workpiece. The zero datum function* clears the display to 0, eliminating this drifting status. (Returning to the nominal display when light is interrupted)

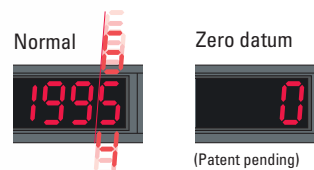

[Supplement]

Datum means reference. Zero datum is a function that changes the light quantity display to 0 when there is on work piece at 0 reference.

*When the retro-reflective type or thru-beam type is used

Popular DSC function

The LV-S series comes with the DSC function.



▶ If the LV-H series is selected in Step 3

LV-H Series Reflective or Retro-Reflective

The main unit comes with an amplifier mounting bracket.
The expansion unit comes with an end unit.

Type*1	Shape (mm)	Number of ON/OFF outputs	External calibration input*2	Laser emission stop input	Analog output	Model		Dimensions
						NPN output	PNP output	
Main unit		2	1	1	0	LV-21A	LV-21AP	➔ P.36
Expansion unit		2	0	0	0	LV-22A	LV-22AP	

*1. The LV-20A is also available to supports the zero line. (It does NOT have a cable for power or outputs).

*2 external inputs on the expansion units can be used for calibration. However, laser emission stop input cannot be used on the expansion units.
Up to seven additional expansion units can be installed for each main unit.

Connectable sensor heads

Reflective	LV-H32, LV-H35, LV-H35F, LV-H37, LV-H42, LV-H47
Retro-Reflective	LV-H62, LV-H67, LV-H62F, LV-H64, LV-H65

Amplifier unit for invisible infrared LV-H41

The amplifier unit comes with the amplifier mounting bracket.

Type	Shape (mm)	Number of ON/OFF outputs	External calibration input	Laser emission stop input	Analog output	Model		Dimensions
						NPN output	PNP output	
Main unit		2	1	1	0	LV-11A		➔ P.36

(Note) Only the LV-H41 and LV-H51 can be used with the LV-11A amplifier.

LV-H Series Thrubeam

The main unit comes with an amplifier mounting bracket.
The expansion unit comes with an end unit.

Type	Shape (mm)	Number of ON/OFF outputs	External calibration input	Laser emission stop input*1	Analog output	Model		Dimensions
						NPN output	PNP output	
Main unit		2	0	1	1	LV-51M	LV-51MP	➔ P.39
Expansion unit		2	0	0	0	LV-52	LV-52P	

*1. Laser emission stop input on the main unit only.

Up to seven additional expansion units can be installed for each main unit.



Connectable sensor heads

Through-beam type	LV-H100, LV-H300, LV-H110
-------------------	---------------------------

LV-S Series



Specifications

Straight-Beam, Retro-Reflective

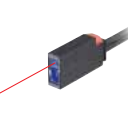
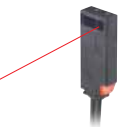

Type	Small beam spot	Area beam	Long-distance transparent object
Model	LV-S61	LV-S62	LV-S63
Shape			
Light source	Visible light semiconductor laser		
Detecting distance*	ULTRA	2m	10m (5m)
	SUPER	1.5m	8m (3.5m)
	TURBO	1m	5m (2m)
	FINE	0.75m	2.5m (0.7m)
	HSP	0.5m	—
Ambient temperature used	-10 to +50°C		
Material	Case	Glass reinforced plastic	
	Lens cover	Acrylic	
	Reflective mirror	Polycarbonate, acrylic	
Weight	Approx. 70 g	Approx. 65 g	Approx. 110 g
Dimensions	➔ P.29	➔ P.25	➔ P.26

* The parentheses indicate the detecting distance when the small beam spot is used.

Reflective

Type	Small	Small side view	Adjustable distance definite reflective
Model	LV-S41	LV-S41L	LV-S31
Shape			
Light source	Visible light semiconductor laser		
Detecting distance	ULTRA	500mm	400mm
	SUPER	400mm	320mm
	TURBO	300mm	240mm
	FINE	200mm	160mm
	HSP	150mm	120mm
Ambient temperature used	-10 to +50°C		0 to 50°C
Material	Case	Glass reinforced plastic	
	Lens cover	Acrylic	
	Reflective mirror	Polycarbonate, acrylic	
Weight	Approx. 70 g		Approx. 75 g
Dimensions	➔ P.28	➔ P.29	➔ P.38

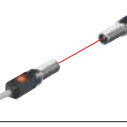
Thrubeam

Type	Small standard	Small (with slit)
Model	LV-S71	LV-S72
Shape		
Light source	Visible light semiconductor laser	
Detecting distance	ULTRA	500mm
	SUPER	
	TURBO	
	FINE	
	HSP	
Ambient temperature used	-10 to +50°C	
Material	Case	Glass reinforced plastic
	Lens cover	Acrylic
	Reflective mirror	Polycarbonate, acrylic
Weight	Approx. 70 g	
Dimensions	➔ P.30	➔ P.30

Type	Side-view attachment for thrubeam	
Model	LV-F1	
Shape		
Applicable head	LV-S71 LV-S72	
Detecting distance	ULTRA	250mm 400mm
	SUPER	
	TURBO	
	FINE	
	HSP	
Ambient temperature used	-10 to +50°C (No condensation)	
Material	Metal part: Stainless steel Mirror part: Glass	
Vibration	10 to 55 Hz, double amplitude: 1.5 mm, 2 hours in each of X, Y and Z axis directions	
Weight	Approx. 22 g	
Dimensions	➔ P.30	

Contains a symmetrical mounting bracket (two in total).

Type	Compact mounting bracket for thrubeam	
Model	OP-66869	
Shape		
Applicable head	LV-S71 LV-S72	
Detecting distance	ULTRA	500mm
	SUPER	
	TURBO	
	FINE	
	HSP	
Ambient temperature used	-10 to +50°C (No condensation)	
Material	Metal part: Stainless steel	
Vibration	10 to 55 Hz, double amplitude: 1.5 mm, 2 hours in each of X, Y and Z axis directions	
Weight	Approx. 14 g	
Dimensions	➔ P.30	

Contains a symmetrical mounting bracket (two in total).



Laser specifications

Sensor head	LV-S31/S41/S41L/S61/S71/S72	LV-S62/S63
Wavelength	655nm	660nm
Output	290μW	290μW
FDA class*	Class 1	
IEC class	Class 1	
JIS class	Class 1	

* IEC60825-1 based classification is made according to FDA (CDRH) Laser Notice No. 50 Regulations.

LV-S Series

Amplifier

Type		Main unit	Expansion unit (1 line)								
Model*1	NPN output	LV-11SB	LV-12SB								
	PNP output	LV-11SBP	LV-12SBP								
Shape											
Response time	Except LV-S31	HSP: 80 μs FINE: 250 μs TURBO: 500 μs SUPER: 2 ms ULTRA: 4ms (LV-S62 and LV-S63 cannot select HSPmode.)									
	LV-S31 standard mode	SPED 1:500 μs SPED 2:2ms SPED 3:8ms SPED 4:32ms									
	LV-S31 high-speed mode	250 μs									
Control output		NPN(PNP) open-collector x 2 ch	40 VDC (30 V) or lower 100 mA max. per output								
Control input		Light emission stop input, external calibration, set value bank selection input, or shift input									
Number of interference preventive units*2		<table border="1"> <thead> <tr> <th>Power mode</th> <th>Number of units</th> </tr> </thead> <tbody> <tr> <td>HSP</td> <td>None</td> </tr> <tr> <td>FINE/TURBO</td> <td>2 units</td> </tr> <tr> <td>SUPER/ULTRA</td> <td>4 units</td> </tr> </tbody> </table>		Power mode	Number of units	HSP	None	FINE/TURBO	2 units	SUPER/ULTRA	4 units
Power mode	Number of units										
HSP	None										
FINE/TURBO	2 units										
SUPER/ULTRA	4 units										
Expansion of unit*3		Up to 16 expansion units can be installed (17 units including the main unit)									
Rating	Power supply voltage*4	12 to 24 VDC ripple (P-P) 10% max. Class 2									
	Power consumption	Normal	1.5 W max. (62.5 mA max. for 24 V)								
		Eco Half Eco All	1.35 max. (57.3 mA max. for 24 V)								
Ambient temperature used*3		-10 to +50°C (No condensation)									
Vibration		10 to 55 Hz, 1.5-mm double amplitude, 2 hours for each X, Y, and Z axis									
Material		Main body, cover: Polycarbonate									
Weight (including 2-m cable)		Approx. 80 g									
Dimensions											

*1. LV-S62 and LV-S63 can ONLY be used with amplifiers ending with B or BP.

*2. Numbers for the LV-S31 are four in standard mode and two in high-speed mode.

*3. To connect several units they must be mounted on a METAL DIN rail. Ensure that the output current is 20mA max. With several units connected, the allowable ambient temperature range varies as follows:

- 1 to 2 units conncted: -10 to +55°C
- 3 to 10 units conncted: -10 to +50°C
- 11 to 16 units conncted: -10 to +45°C

*4. When more than 8 units connected, be sure to use supply voltage 24 VDC Ripple (P-P) 10% max.

Input/Output Circuits

Output circuit

LV-11SB/12SB

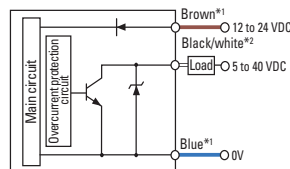

*1. The LV-11SB only

*2. Black: Control output 1, white: Control output 2

LV-11SBP/12SBP

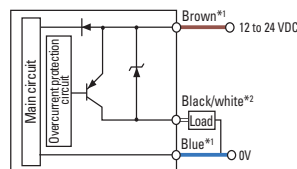

*1. The LV-11SBP only

*2. Black: Control output 1, white: Control output 2

Input circuit

Laser emission stop input/External calibration input/Setting value bank selection input/Received light intensity shift input

LV-11SB/12SB

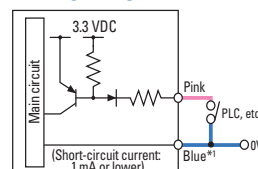

* The LV-11SB only

LV-11SBP/12SBP

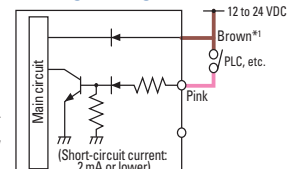

* The LV-11SBP only

STEP 1

STEP 2

STEP 3



STEP 4

SPECIFICATIONS

DIMENSIONS



LV-H Series

Straight-Beam, Retro-Reflective

Type	Small beam spot	High power
Model	LV-H62	LV-H67
Shape		
FDA class	Class II	
IEC class	Class 2	
Light source	Visible light semiconductor laser Wavelength: 660 nm	
Detecting distance	FINE	2m
	TURBO	5m
	SUPER	7m
Ambient temperature used	-10 to +55°C (No condensation)	
Material	Case	Glass reinforced plastic
	Lens cover	Transparent plastic*2
	Reflective mirror	Polycarbonate, Acrylic
Weight	Approx. 45 g	
Dimensions		



*1 The detecting distance is 50 m when **OP-42198** is used.
 *2 Norbornene plastic or acrylic

Area Beam, Retro-Reflective

Type	Long distance	Wide
Model	LV-H64	LV-H65
Shape		
FDA class	Class II	
IEC class	Class 2	
Light source	Visible light semiconductor laser Wavelength: 660 nm	
Detecting distance	FINE	100 to 500 mm (100 to 700 mm)
	TURBO	200 to 850 mm (300 to 1000 mm)
	SUPER	400 to 1200 mm (600 to 1500 mm)
Ambient temperature used	-10 to +55°C (No condensation)	
Material	Case	Reinforced glass/plastic
	Lens	Norbornene plastic
	Reflective mirror	Polycarbonate, acrylic
Weight	Approx. 45 g	
Dimensions		



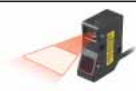

* The parentheses indicate the detecting distance when **OP-51428** is used.

Area Beam

Type	Area definite reflective	Long-distance area
Model	LV-H47	LV-H42 LV-H41
Shape		
FDA class	Class II	
IEC class	Class 2	
Light source	Visible light semiconductor laser Wavelength: 660 nm	
Detecting distance	FINE	250mm
	TURBO	500mm
	SUPER	1000mm
Ambient temperature used	-10 to +55°C (No condensation)	
Ambient humidity used	35% to 85% RH (No condensation)	
Material	Case	Glass reinforced plastic
	Lens cover	Glass*1
Weight	Approx. 45 g	
Dimensions		



*1. The receiver is polyarylate.

Small Beam Spot

Type	Straight-beam coaxial	Adjustable beam spot	Ultra-small beam spot
Model	LV-H35	LV-H32	LV-H37
Shape			
FDA class	Class II		
IEC class	Class 2		
Light source	Visible light semiconductor laser Wavelength: 660 nm		
Detecting distance	FINE	150mm	250mm
	TURBO	300mm	500mm
	SUPER	600mm	1000mm
Ambient temperature used	-10 to +55°C (No condensation)		
Ambient humidity used	35% to 85% RH (No condensation)		
Material	Case	Glass reinforced plastic*1	
	Lens cover	Transparent plastic	Acrylic*2
			Glass*2
Weight	Approx. 45 g		
Dimensions			

*1 Norbornene plastic or acrylic
 *2 The **LV-H32** and the **LV-H37** receivers are polyarylate





Waterproof (IP67)

Type	Straight-beam coaxial	Retro-reflective
Model	LV-H35F	LV-H62F
Shape		
FDA class	Class II	
IEC class	Class 2	
Light source	Visible light semiconductor laser Wavelength: 660 nm	
Detecting distance	FINE	100 mm
	TURBO	200 mm
	SUPER	450 mm
Ambient temperature used	-10 to +55°C (No condensation)	
Ambient humidity used	35% to 85% RH (No condensation)	
Material	Case	Fluoroplastic (PFA)
	O-ring	Fluororubber
	Lens cover	Glass
Weight	Approx. 80 g	Approx. 100 g
Dimensions		

* The cable minimum bend radius is 25mm.

LV-H Series

Amplifier Specifications (for reflective/retro-reflective sensor heads)

Model	NPN Output	LV-21A	LV-22A	LV-20A	LV-11A(dedicated to LV-H41)
	PNP Output	LV-21AP	LV-22AP		
Shape					
Main unit / Expansion unit	Main unit		Expansion unit (1 line)		Expansion unit (0 line)
Response speed	FINE: 80 μs/ TURBO: 500 μs/ SUPER TURBO: 4 ms			280 μs to 4.7 ms	
Control output	NPN (PNP) open-collector x 2 channels, 40 VDC (30 V) max., max. 100 mA, residual voltage (1.0 V max.)				
Protection circuit	Reverse polarity protection, overcurrent protection, surge absorption				
Expansion of units	Up to 7 additional expansion units can be installed (8 units including the main unit),				
Number of interference preventive units ^{*1}	Power mode	FINE	TURBO	SUPER	
	Number of units	None	2 units	4 units	
Rating	Power supply voltage	12 to 24 VDC ripple (P-P) 10% max. (For the LV-20A/22A/22AP, the power supply voltage is supplied from the main unit.)			
	Power consumption	1.5 W max. (125 mA max. for 12 V, 62.5 mA max. for 24 V)			
Ambient temperature used	-10 to +55°C (No condensation) ^{*2}				
Ambient humidity used	35% to 85% RH (No condensation)				
Material	Main body, cover: Polycarbonate				
Weight	Approx. 120 g			Approx. 75 g	
Dimensions					

* 1 To connect several units they must be mounted on a METAL DIN rail. Ensure that the output current is 20 mA max. With several units connected, the allowable ambient temperature range varies as follows:

* 2 When 2 to 5 expansion units are additionally installed: -10°C to +50°C. When 6 or 7 expansion units are additionally installed: -10°C to +45°C.

LV-L01 Specifications (lens attachment for LV-H42) (Unit: mm)

Name		LV-L01	When slit 1 is mounted	When slit 2 is mounted	When slit 3 is mounted	When slit 4 is mounted
Detecting distance	FINE	200	175	150	125	100
	TURBO	400	350	300	250	200
	SUPER	800	700	600	500	400
Area thickness	50 mm			2.6		
	100 mm			4.0		
	150 mm			5.5		
Area width	50 mm	15.0	11.5	9.5	7.5	5.5
	100 mm	26.0	20.0	17.0	13.0	10.0
	150 mm	37.0	29.0	24.0	19.0	14.0
Case material	Polyacetal (main body) Arton (lens)					
Weight	Approx. 1 g					
Dimensions						

Typical example of "width x thickness" of area in LV-L01 detecting distance (Unit: mm)

Distance	LV-H42	LV-H42+black slit	LV-H42+grey slit	LV-L01	L01+slit 1	L01+slit 2	L01+slit 3	L01+slit 4
100	26 x 0.6	13 x 0.6	5 x 0.6	27 x 4	20 x 4	17 x 4	13 x 4	10 x 4
200	48 x 0.4	25 x 0.4	9 x 0.4	49 x 7	38 x 7	32 x 7	25 x 7	19 x 7
300	70 x 0.8	36 x 0.8	13 x 0.8	72 x 10	56 x 10	47 x 10	36 x 10	27 x 10
400	92 x 1.34	48 x 1.34	17 x 1.34	94 x 13	73 x 13	61 x 13	48 x 13	36 x 13

LV-L02 Specifications (lens attachment for LV-H47) (Unit: mm)

Name		LV-L02	When slit 1 is mounted	When slit 2 is mounted	When slit 3 is mounted	When slit 4 is mounted
Area thickness	55 mm			3.0		
	70 mm			3.4		
	85 mm			3.8		
Area width	55 mm	17.0	13.0	11.0	8.5	6.0
	70 mm	20.5	15.5	13.0	10.0	7.5
	85 mm	24.0	18.0	15.0	11.5	9.0
Case material	Polyacetal (main body) Arton (lens)					
Weight	Approx. 1 g					
Dimensions						

STEP 1

STEP 2

STEP 3



STEP 4

SPECIFICATIONS

DIMENSIONS



LV-H Series

Thrubeam

Type	Area thrubeam		
	High power	High performance	
Model	LV-H110	LV-H100	LV-H300
Shape			
Detecting area	10 mm		30 mm
FDA class	Class II		
IEC class	Class 2		
Light source	Visible light semiconductor laser Wavelength: 660 nm		
Detecting distance	2000 mm		
Ambient temperature used	-10 to +55°C (No condensation)		
Ambient humidity used	35% to 85% RH (No condensation)		
Material	Glass reinforced plastic		
	Case	Transmitter: Glass Receiver: Polyarylate	
Weight	Approx. 80 g		Approx. 100 g
Dimensions			

* Use a dedicated mounting bracket to install the sensor.

Amplifier Specifications

Model	NPN Output	LV-51M	LV-52
	PNP Output	LV-51MP	LV-52P
Main unit/ Expansion unit	Main unit		Expansion unit (1 line)
Shape			
Response speed	FINE	TURBO	SUPER
	80 μs	500 μs	4 ms
Inspection mode	Light intensity distinction / edge detection		
Control output	NPN (PNP) open-collector x 2 channels, 40 VDC (30 V) or lower, max. 100 mA, residual voltage (1.0 V or lower)		
Monitor output	1 - 4 V for 1 - 4 V voltage output and FINE display 0 - 3000, load resistance 20 kΩ or higher (LV-51M/LV-51MP only)		
Protection circuit	Reverse polarity protection, overcurrent protection, surge absorption		
Expansion of units	Up to 7 additional expansion units can be installed (8 units including the main unit),		
Number of interference preventive units*1	FINE: No device (0) TURBO: 2 units SUPER: 4 units		
Rating	Power supply voltage	12 to 24 VDC ripple (P-P) 10% max. (For the LV-52/52P , the power supply voltage is supplied from the main unit.)	
	Power consumption	1.5 W max. (125 mA max. for 12 V, 62.5 mA max. for 24 V)	
Ambient temperature used	-10 to +55°C (No condensation)*1		
Ambient humidity used	35% to 85% RH (No condensation)		
Material	Main body, cover: Polycarbonate		
Weight	Approx. 120 g		Approx. 75 g
Dimensions			

*1 To connect several units they must be mounted on a METAL DIN rail. Ensure that the output current is 20 mA max. With several units connected, the allowable ambient temperature range varies as follows:
 When 2 to 5 expansion units are additionally installed: -10°C to +50°C.
 When 6 or 7 expansion units are additionally installed: -10°C to +45°C.

LV-H / LV-S Series

Input/Output Circuits

NPN

LV-21A/11A/51M

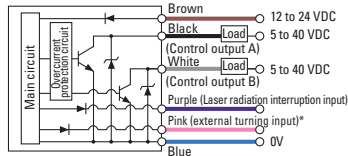

* Orange (monitor output) only for LV-51M

NPN

LV-22A/52

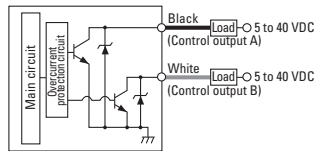

Laser emission interruption (main unit only) External calibration input

NPN

LV-21A/11A/51M

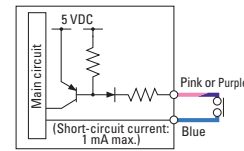

PNP

LV-21AP/51MP

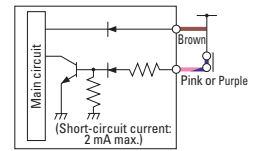

PNP

LV-21AP/51MP

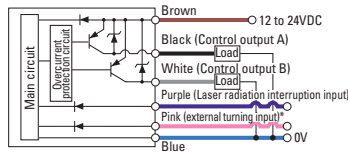

* Orange (monitor output) only for LV-51MP

PNP

LV-22AP/52P

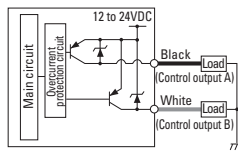

Analogue output circuit diagram for monitor (LV-51M/51MP only)

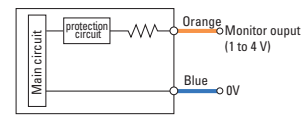

Dimensions

Unit: mm



LV-S62

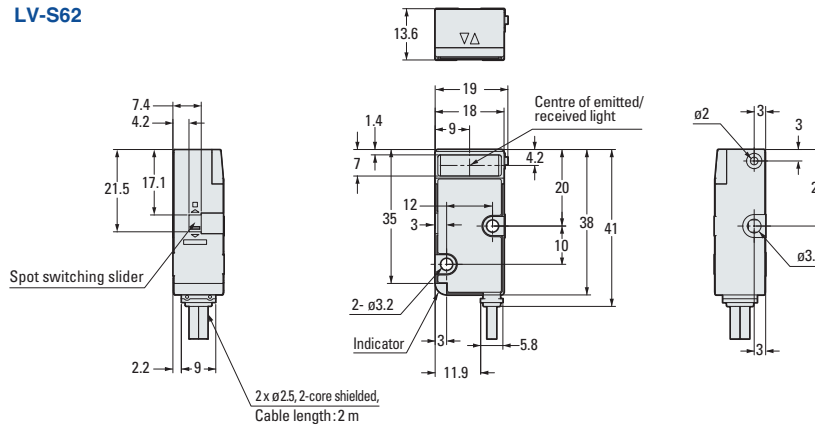

Reflector R-6L (LV-S62 accessory)

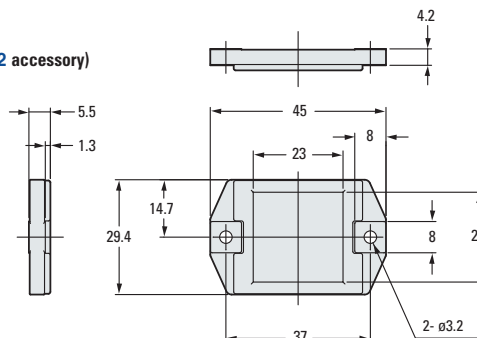

LV-S Series



OP-84350 L-shape mounting bracket for LV-S62 (Option)

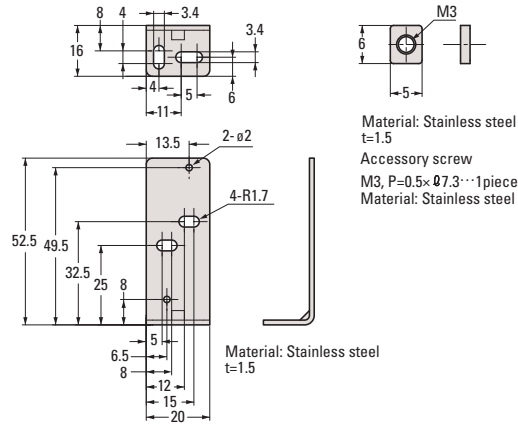

Mounting bracket attached

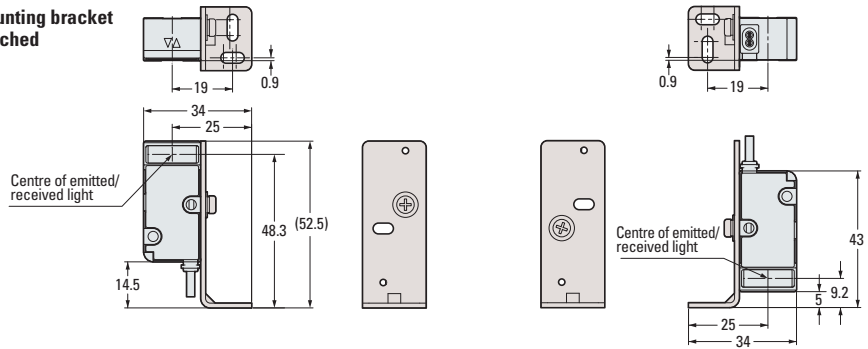

OP-84349 Rear mounting bracket for the LV-S62 (Option)

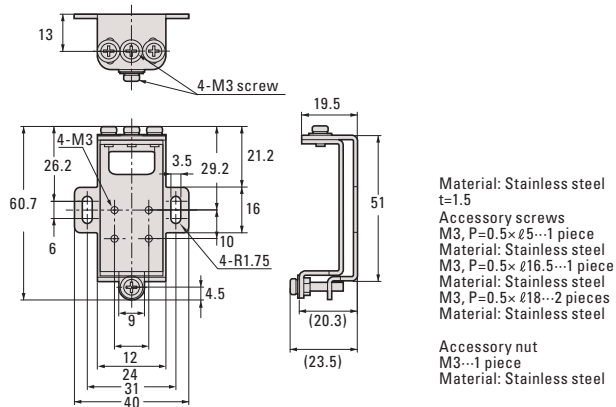

Mounting bracket attached

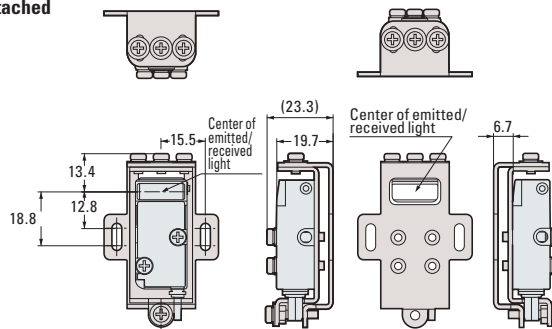

LV-S Series

Unit: mm



OP-84351
Side mounting bracket for LV-S62 (Option)

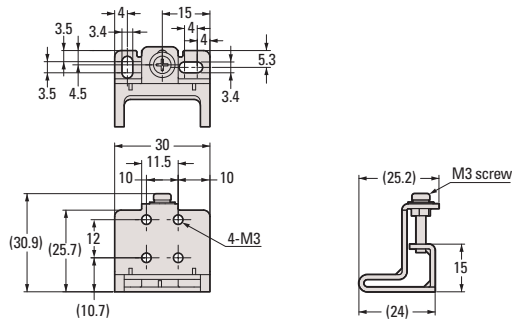

Material: Stainless steel
t=1.5

Accessory screws
M3, P=0.5×016.5...1piece
Material: Stainless steel
M3, P=0.5×018...2piece
Material: Stainless steel

Accessory nut
M3...1 piece
Material: Stainless steel

Mounting bracket attached

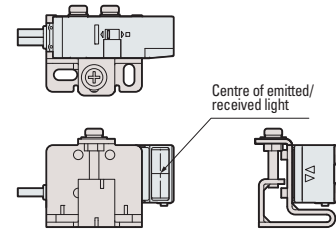
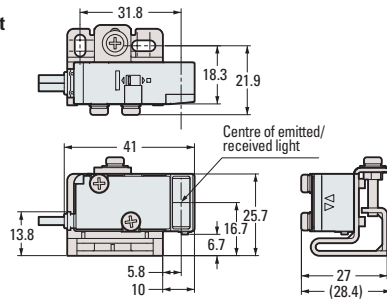

LV-S63

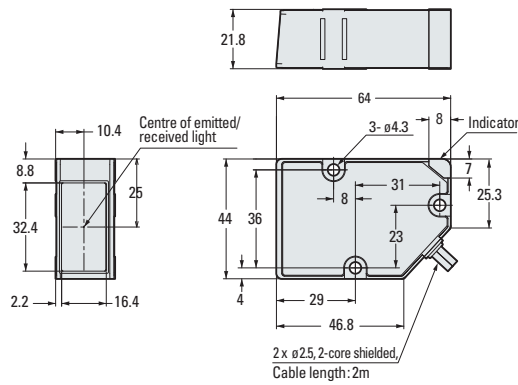

Reflector R-9
(LV-S63 accessory)

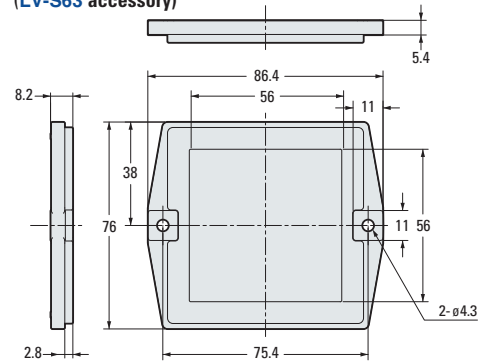

Rear mounting bracket for LV-S63 (Accessory)

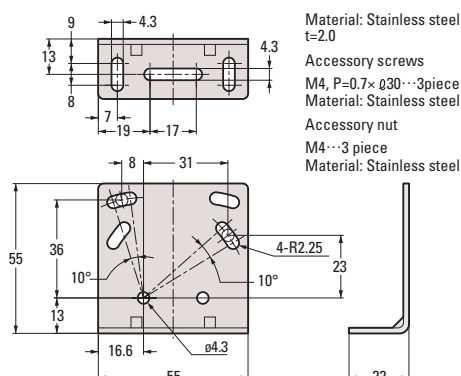

Material: Stainless steel
t=2.0
Accessory screws
M4, P=0.7×030...3piece
Material: Stainless steel
Accessory nut
M4...3 piece
Material: Stainless steel

Mounting bracket attached

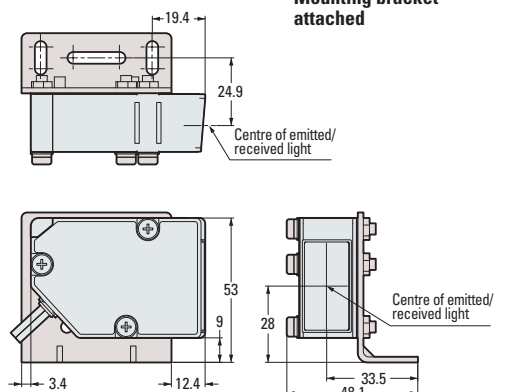

LV-S Series



LV-S31

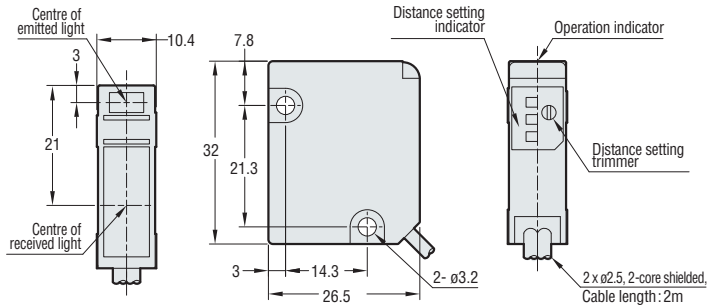

L-shape mounting bracket for LV-S31 (Accessory)

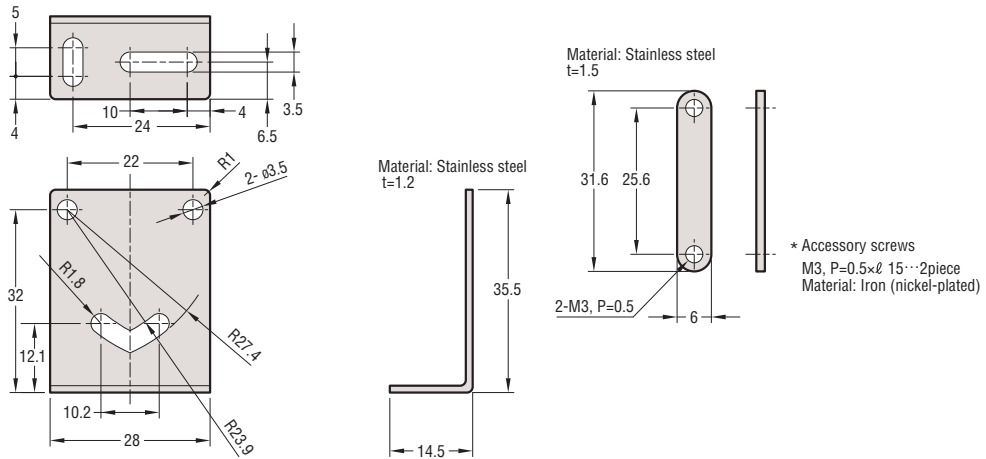

LV-S41

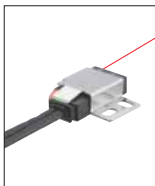
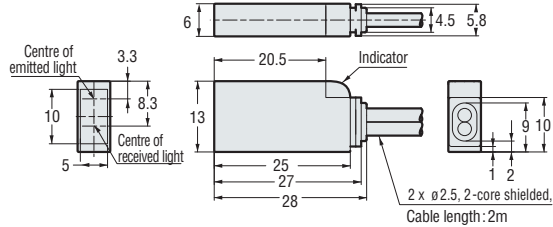

Installed bracket on the LV-S41

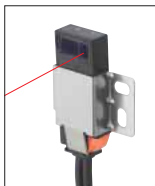

Installed bracket on the LV-S41L

Mounting bracket for LV-S41/LV-S41L (Accessory)

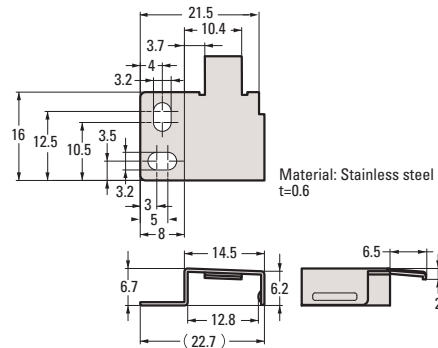

LV-S Series

Unit: mm

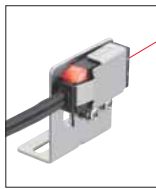
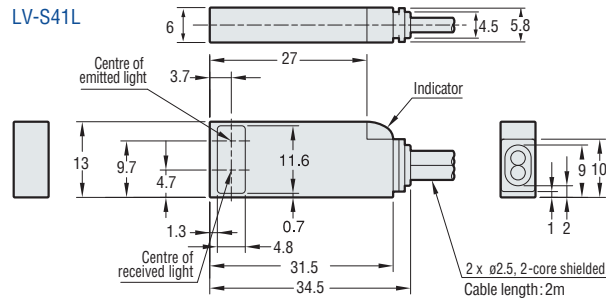

Installed bracket on the LV-S41

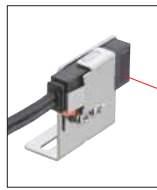

Installed bracket on the LV-S41L

OP-66846
L-shape mounting bracket for LV-S41/LV-S41L (Option)

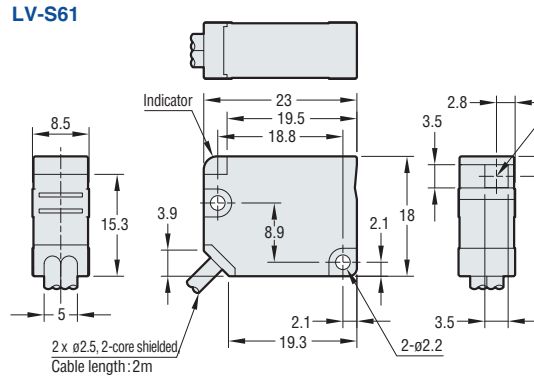
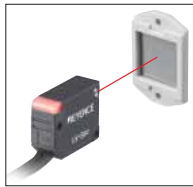
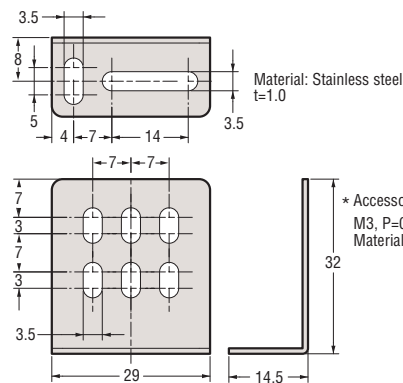

OP-51430 R-6 (Grey) (Accessory)

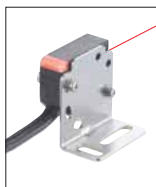
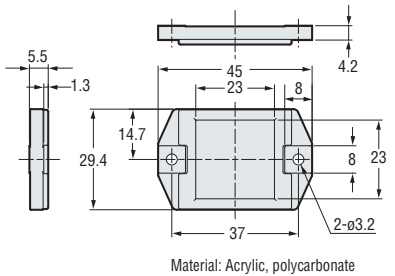

L-shape mounting bracket for LV-S61 (Accessory)

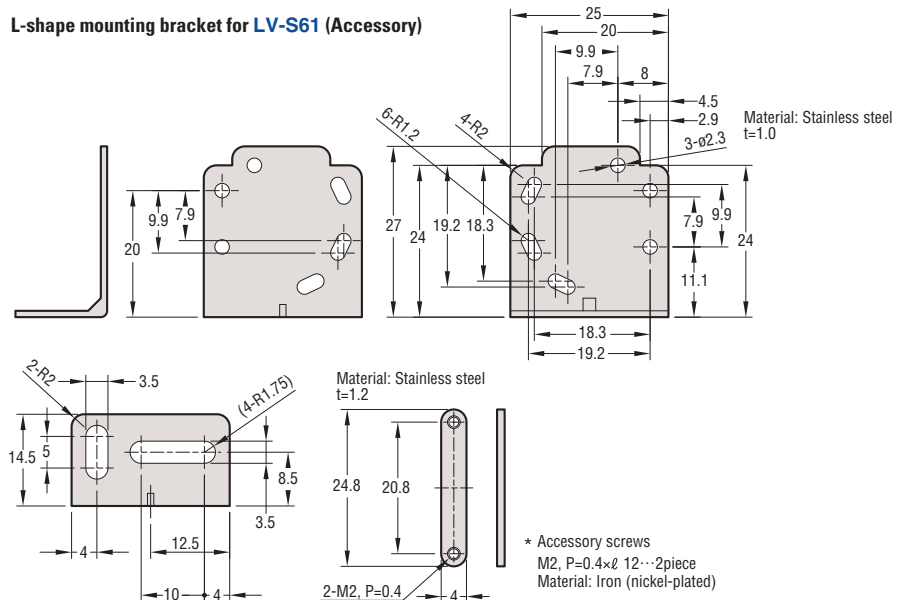

LV-S Series

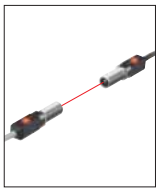

LV-S71

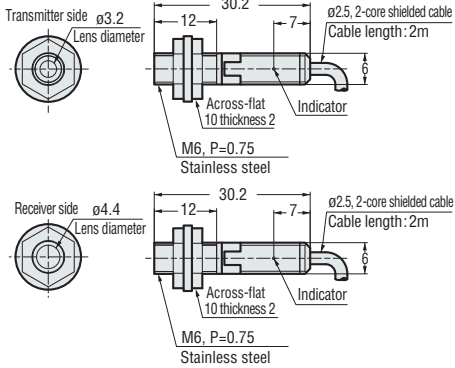

LV-S72

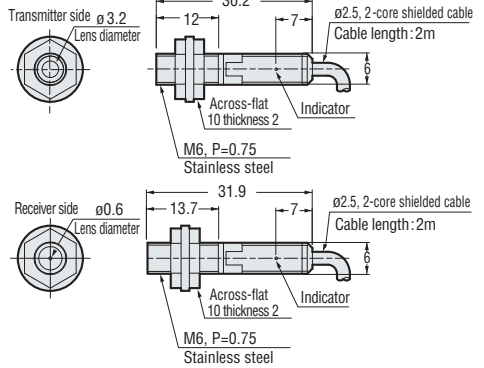

Mounting bracket for LV-S71 / LV-S72 (Accessory)

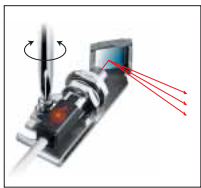
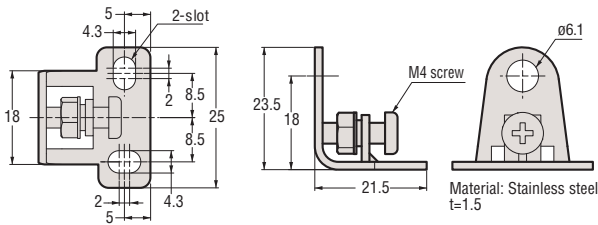

LV-F1

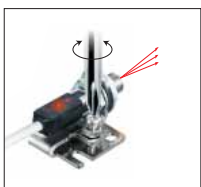
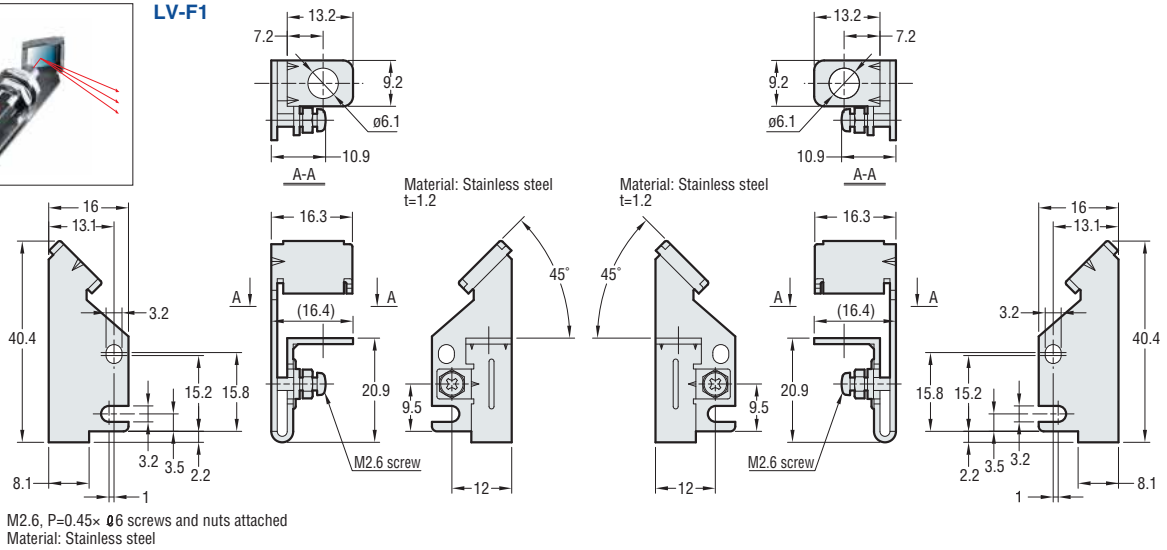

OP-6869

Compact mounting bracket for thrubeam (Option)

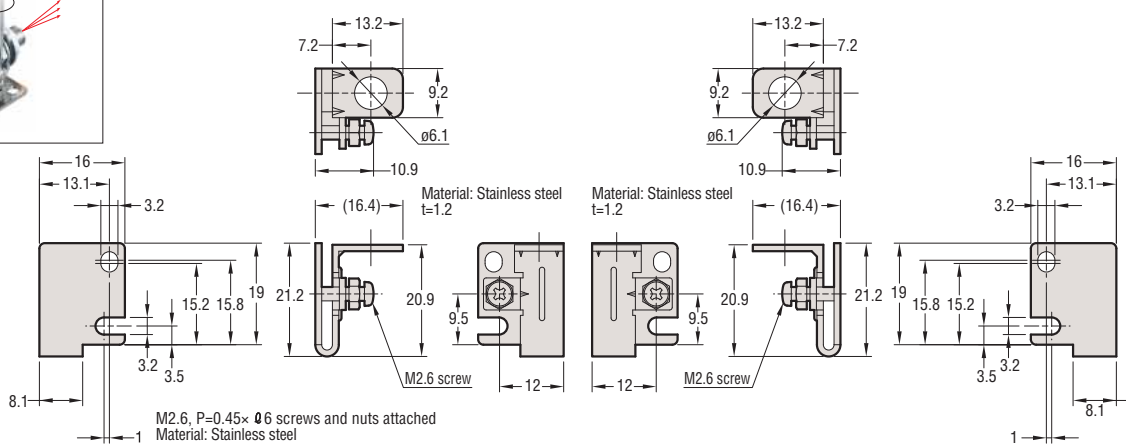

LV-S Series

Unit: mm



LV-11SB/11SBP

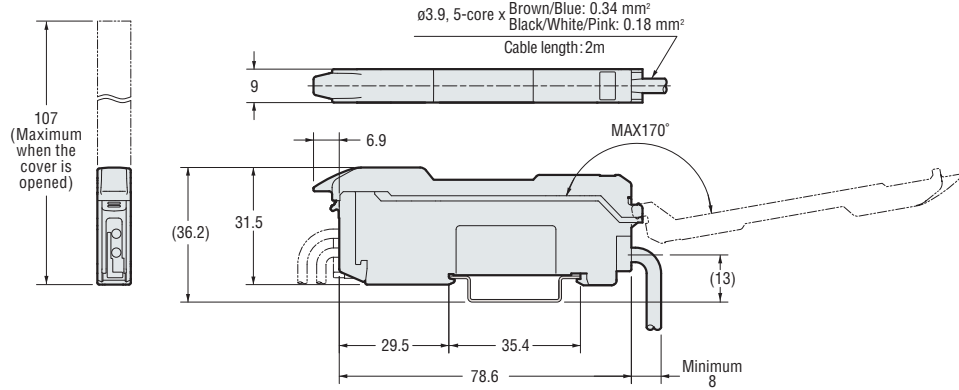

Mounting bracket attached (LV-11SB and LV-11SBP DIN rail accessory)

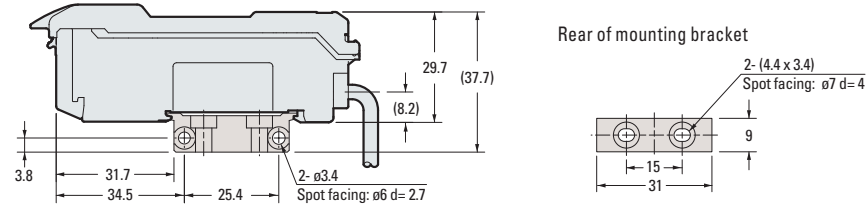

LV-12SB/12SBP

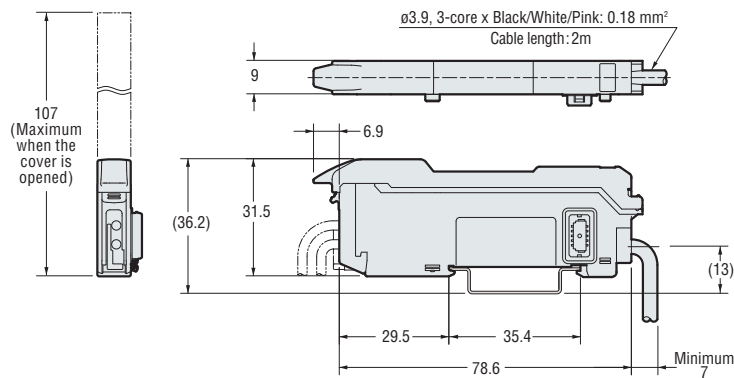

End unit (included with LV-12SB/LV-12SBP)

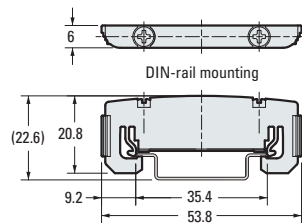

When several units are connected

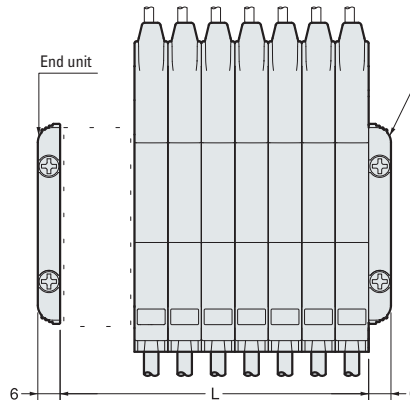

* Make sure to use end units when adding expansion units.

No. of expansion units	L	No. of expansion units	L
1	18	9	90
2	27	10	99
3	36	11	108
4	45	12	117
5	54	13	126
6	63	14	135
7	72	15	144
8	81	16	153

LV-H Series

LV-H series reflective/retro-reflective



LV-H35F/H62F

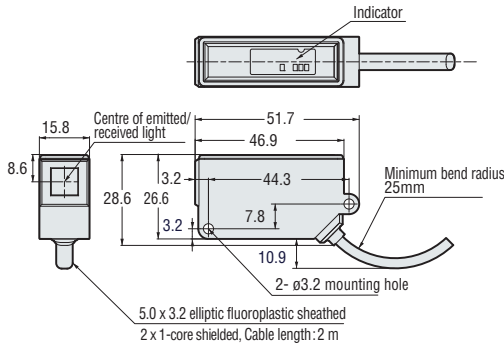

Mounting bracket (Accessory)

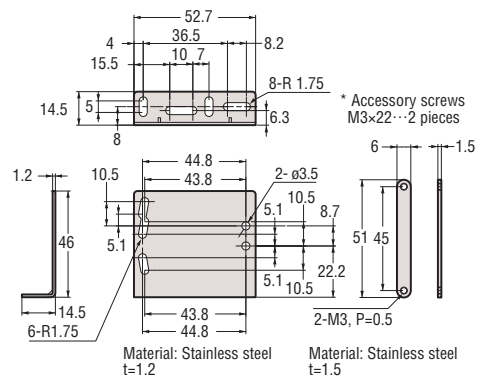

Reflector R-8 for LV-H62F (Accessory)

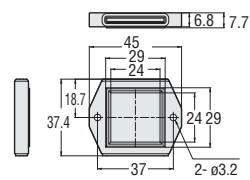

Mounting bracket attached

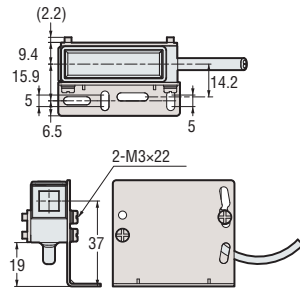

LV-H35/H62/H67

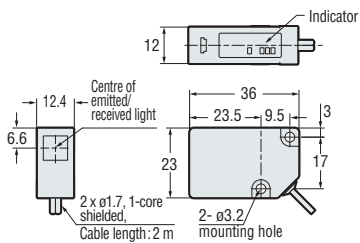

Mounting bracket (Accessory)

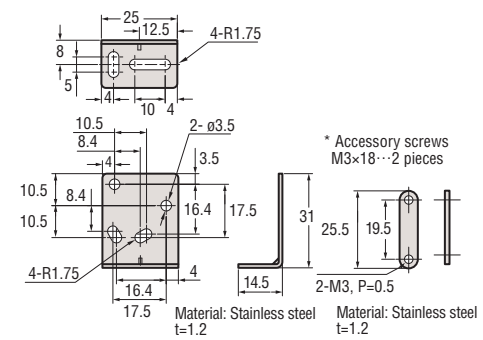

Reflector R-6 for LV-H62 (Accessory)

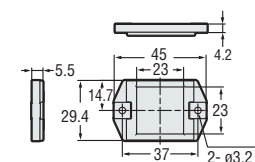

Reflector R-7 for LV-H62 (Accessory)

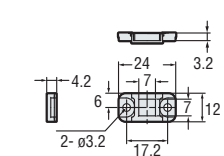

LV-H Series

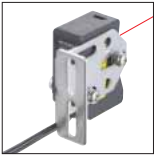

Mounting bracket attached
(LV-H37/H47 accessory)

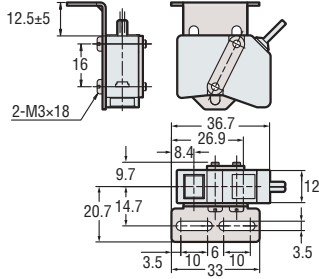

When mounting LV-L01
(LV-H42/41)

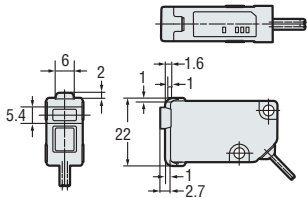

Slit sticker (included with LV-L01)

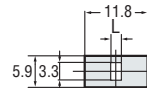

Slit sticker name	L
Slit 1	2.6
Slit 2	2.0
Slit 3	1.5
Slit 4	1.1



LV-H42/41

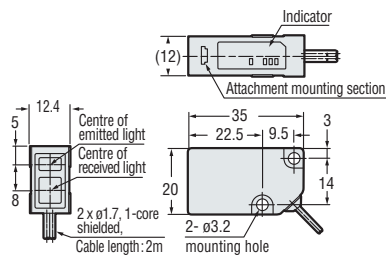

Mounting bracket for LV-H42/41
(Accessory)

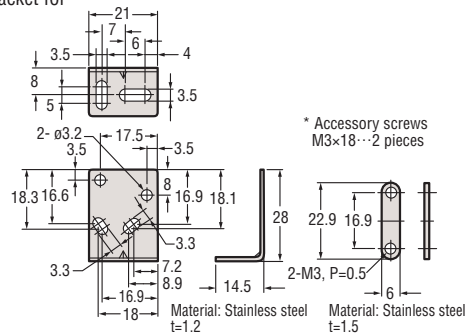

LV-H42/41
(Mounting bracket attached)

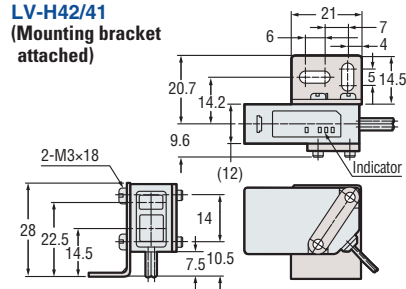

LV-H42/41
When mounting the accessory slit

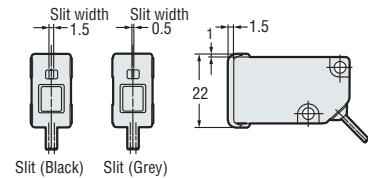

When mounting LV-L02
(LV-H47)

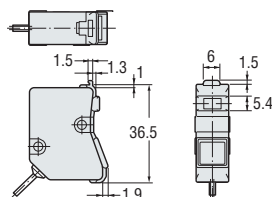

Slit sticker (included with LV-L02)

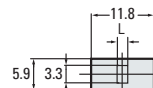

Slit sticker name	L
Slit 1	2.6
Slit 2	2.0
Slit 3	1.5
Slit 4	1.1

LV-H Series

Unit: mm



LV-H64

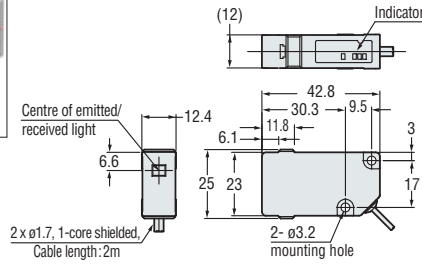

LV-H65

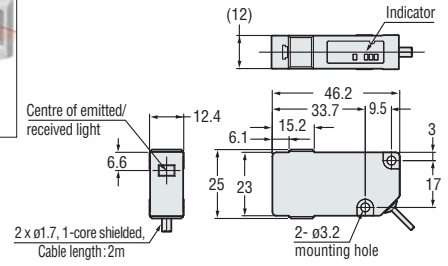

Reflector OP-51430 (R-6 grey) for LV-H64/H65 (Accessory)

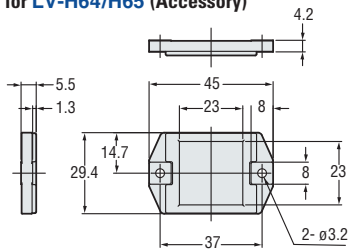

Mounting bracket for LV-H64/H65 (Accessory)

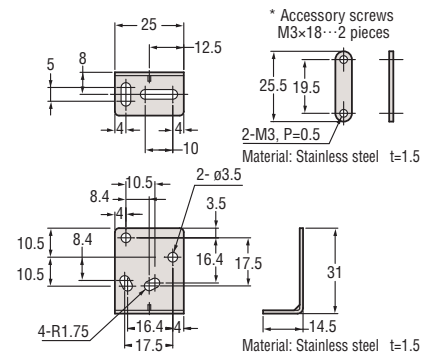

LV-H64/H65 (Mounting bracket attached)

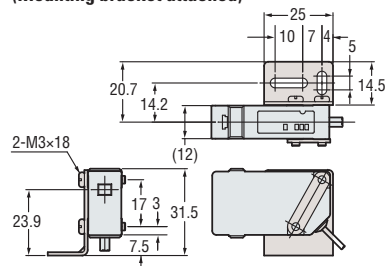

Optional reflective tape OP-51428

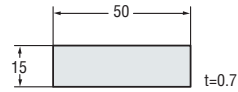

LV-H Series



LV-21A/21AP/11A

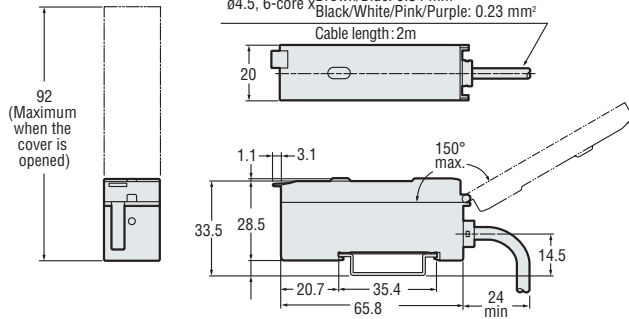

Mounting bracket attached (included with LV-21A/11A)

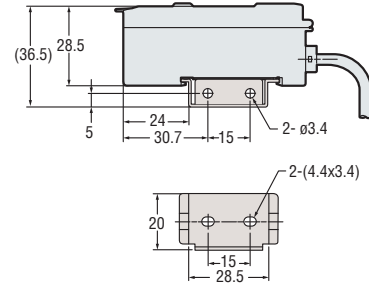

LV-22A/22AP

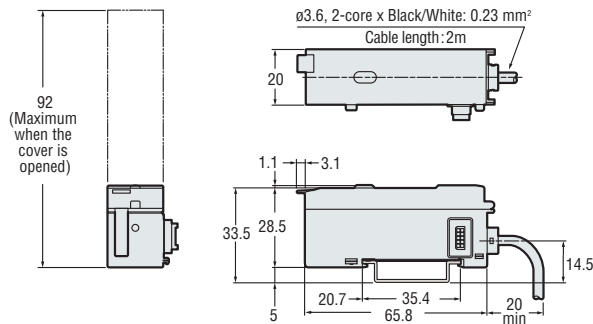

LV-20A

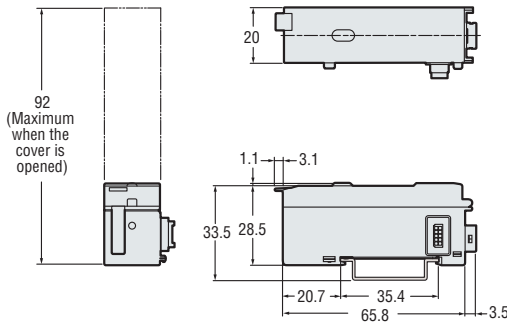

End unit (included with LV-22A/22AP)

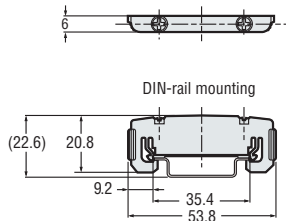

When several units are connected:

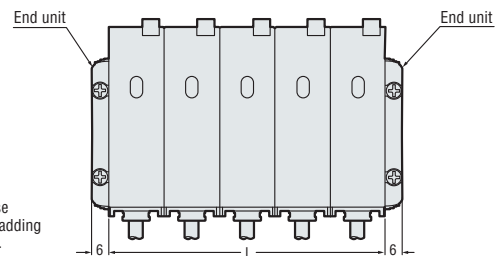

* Make sure to use end units when adding expansion units.

No. of units	L
1	40
2	60
3	80
4	100
5	120
6	140
7	160

LV-H Series

Unit: mm

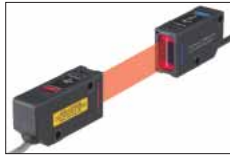

LV-H100/H110 (Transmitter)

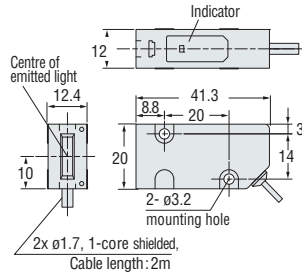

LV-H100/H110 (Receiver)

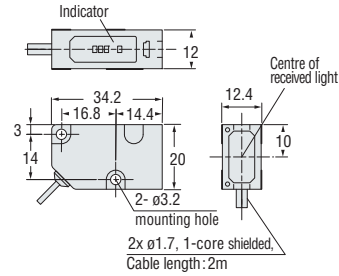

LV-B101 (Mounting bracket set includes 2 brackets for transmitter/receiver for LV-H100/H110)

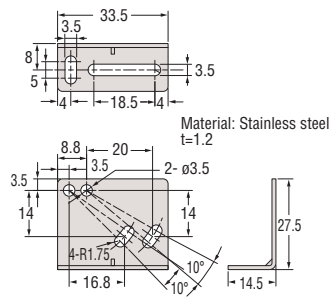

Plate nut for transmitter

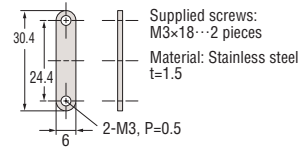
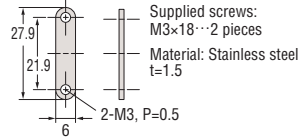
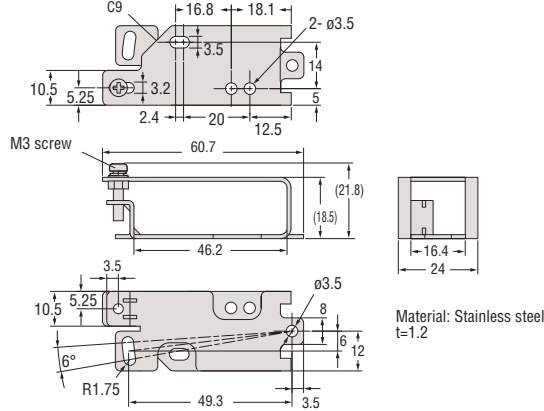

Plate nut for receiver



LV-B102 (Mounting bracket set includes 2 brackets for transmitter/receiver for LV-H100/H110)



When the transmitter of the LV-H100/H110 is mounted (Inside)

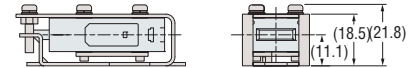

When the receiver of the LV-H100/H110 is mounted (Inside)



When the transmitter of the LV-H100/H110 is mounted (Outside)

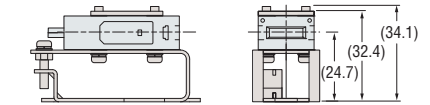

When the receiver of the LV-H100/H110 is mounted (Outside)

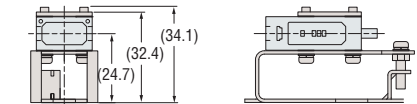

Plate nut for transmitter

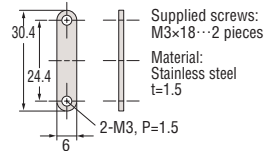
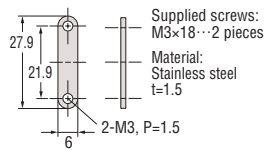
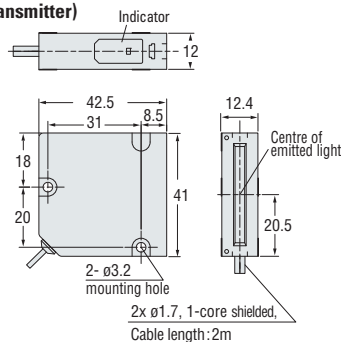

Plate nut for receiver



LV-H300 (Transmitter)



LV-H300 (Receiver)

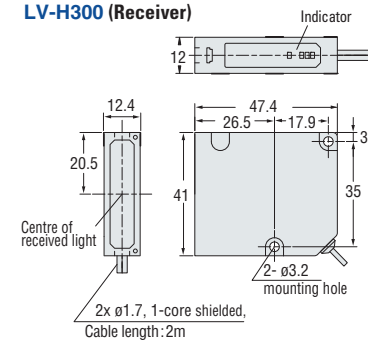

LV-H Series



LV-B301
(Mounting bracket for LV-H300, included two brackets for the transmitter and receiver.)

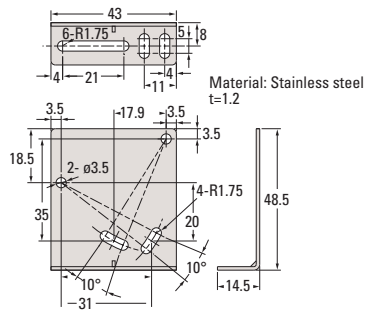

Plate nut for transmitter

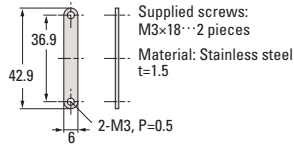
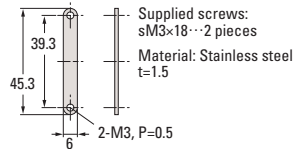
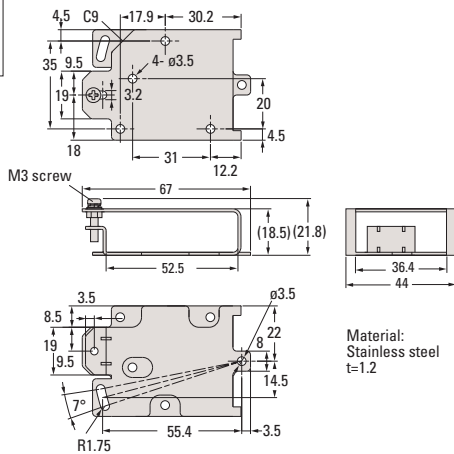

Plate nut for receiver



LV-B302
(Mounting bracket for LV-H300, included two brackets for the transmitter and receiver.)



When the transmitter of the LV-H300 is mounted (Inside)

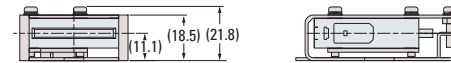

When the receiver of the LV-H300 is mounted (Inside)

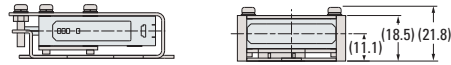

When the transmitter of the LV-H300 is mounted (Outside)

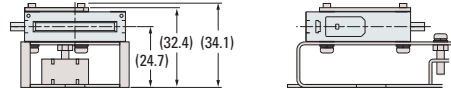

When the transmitter of the LV-H300 is mounted (Outside)

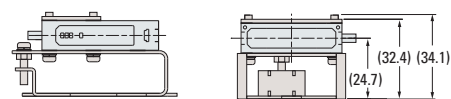

Plate nut for transmitter

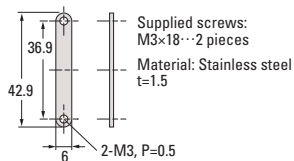
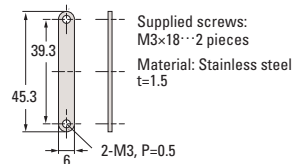

Plate nut for receiver



LV-H Series

Unit: mm



LV-51M/51MP

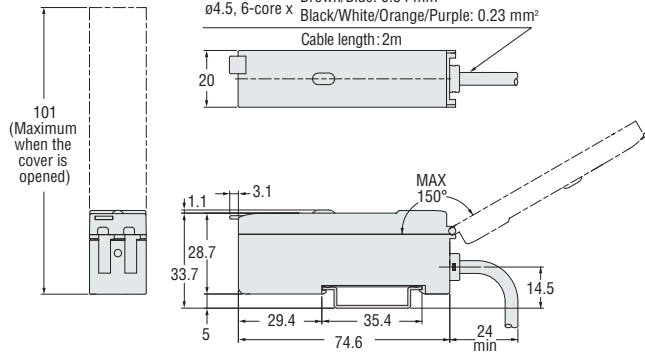

Mounting bracket attached (LV-51M/51MP accessory)

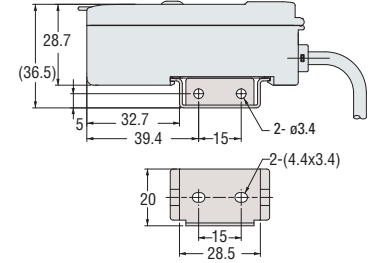

LV-52/52P

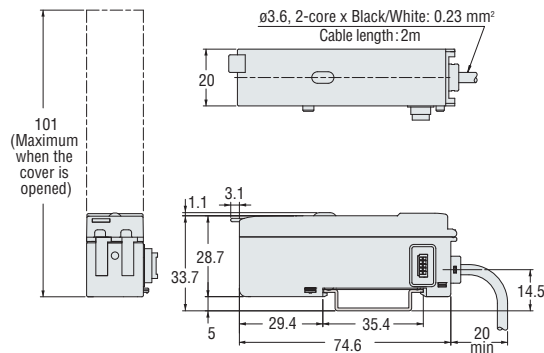

End unit (LV-52/52P accessory)

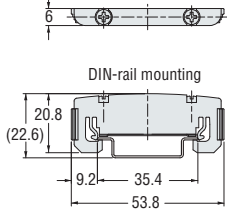

No. of units	L
1	40
2	60
3	80
4	100
5	120
6	140
7	160

When several units are connected:

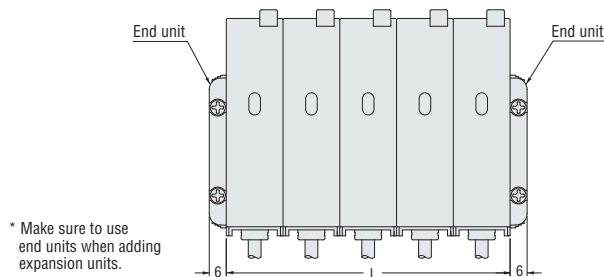



Please visit: www.keyence.com



SAFETY INFORMATION

Please read the instruction manual carefully in order to safely operate any KEYENCE product.

GLOBAL NETWORK

CONTACT YOUR NEAREST OFFICE FOR RELEASE STATUS.

AUSTRIA
Phone: +43-2236-378266-0

CZECH REPUBLIC
Phone: +420-222-191-483

INDIA
Phone: +91-44-4963-0900

MALAYSIA
Phone: +60-3-7883-2211

SINGAPORE
Phone: +65-6392-1011

THAILAND
Phone: +66-2-369-2777

BELGIUM
Phone: +32-15-281-222

FRANCE
Phone: +33-1-56-37-78-00

INDONESIA
Phone: +62-21-2966-0120

MEXICO
Phone: +52-55-8850-0100

SLOVAKIA
Phone: +421-25939-6461

UK & IRELAND
Phone: +44 (0) 1908-696-900

BRAZIL
Phone: +55-11-3045-4011

GERMANY
Phone: +49-6102-3689-0

ITALY
Phone: +39-02-6688220

NETHERLANDS
Phone: +31-40-20-66-100

SLOVENIA
Phone: +386-1-4701-666

USA
Phone: +1-201-930-0100

CANADA
Phone: +1-905-366-7655

HONG KONG
Phone: +852-3104-1010

JAPAN
Phone: +81-6-6379-2211

POLAND
Phone: +48-71-36861-60

SWITZERLAND
Phone: +41-43-455-77-30

VIETNAM
Phone: +84-4-3772-5555

CHINA
Phone: +86-21-5058-6228

HUNGARY
Phone: +36-1-802-73-60

KOREA
Phone: +82-31-789-4300

ROMANIA
Phone: +40-269-232-808

TAIWAN
Phone: +886-2-2721-8080