

NAMUR M8

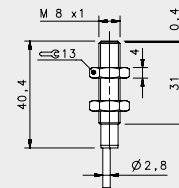
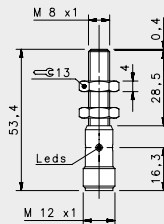
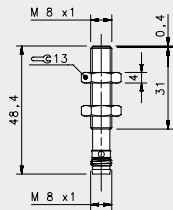

NAMUR FLUSH

NOMINAL SWITCHING DISTANCE				M8 conn	M12 conn	cable
				1 mm	1 mm	1 mm
10-30 Vdc	PNP/NPN NO-NC	4 wires	order No.	---	---	---
10-30 Vdc	PNP NO	3 wires	order No.	---	---	---
10-30 Vdc	PNP NC	3 wires	order No.	---	---	---
10-30 Vdc	NPN NO	3 wires	order No.	---	---	---
10-30 Vdc	NPN NC	3 wires	order No.	---	---	---
10-30 Vdc	PNP NO-NC	4 wires	order No.	---	---	---
10-30 Vdc	NPN NO-NC	4 wires	order No.	---	---	---
10-30 Vdc	NO-NC	2 wires	order No.	---	---	---
20-250 Vac/Vdc	NO	2 wires	order No.	---	---	---
20-250 Vac/Vdc	NC	2 wires	order No.	---	---	---
20-250 Vac	NO	2/3wires	order No.	---	---	---
10-30 Vdc	Analog 0-20 mA	3 wires	order No.	---	---	---
NAMUR amplifier	NAMUR	2 wires	order No.	IS-08-A20-S1 95B066780	IS-08-A20-S2 95B066760	S-08-A20-03 95B066740
Nominal Voltage				7,7 +9 V DC	7,7 +9 V DC	7,7 +9 V DC
Residual Ripple				< 10%	< 10%	< 10%
Hysteresis				< 10%	< 10%	< 10%
Max. Output Current				< 3 mA (metal absent)	< 3 mA (metal absent)	< 3 mA (metal absent)
Min. Output Current				< 1 mA (metal present)	< 1 mA (metal present)	< 1 mA (metal present)
Residual Current				---	---	---
Voltage Drop				---	---	---
Operation Led				---	---	---
Switching Frequency				2000 Hz	2000 Hz	2000 Hz
Start Up Delay				---	---	---
Repeatability				< 3%	< 3%	< 3%
Short Circuit Protection				Present (self-resetting)	Present (self-resetting)	Present (self-resetting)
Electric Protection				Against polarity reversal inductive loads	Against polarity reversal inductive loads	Against polarity reversal inductive loads
Temperature Limit				(-25 ... +60 °C)	(-25 ... +60 °C)	(-25 ... +60 °C)
Protection Degree				IP67	IP67	IP67
Cable Length				---	---	2 m
Cable Section				---	---	2x 0,25 mm ²
Housing Material				Nickel-plated brass	Nickel-plated brass	Nickel-plated brass
Active face				LCP	LCP	LCP
Tightening torque				4Nm	4Nm	4Nm
Weight - Cable Output				---	---	80 g
Weight - Connector Output				35g	55g	---

NAMUR M12

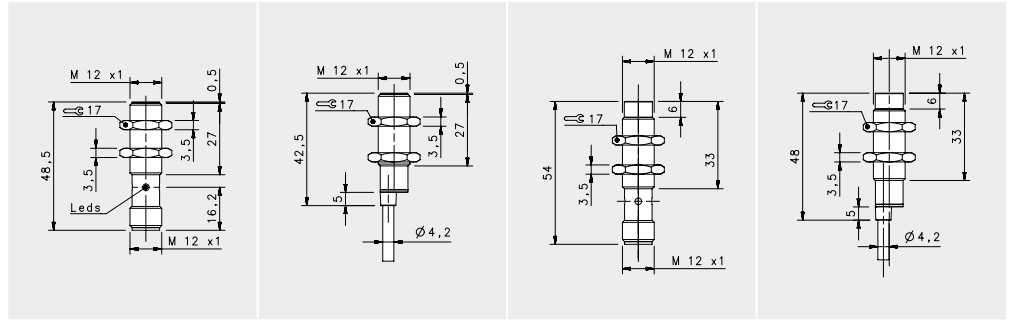

NAMUR

FLUSH

NON FLUSH

NOMINAL SWITCHING DISTANCE

				FLUSH		NON FLUSH	
				M12 conn	cable	M12 conn	cable
				2 mm	2 mm	4mm	4mm
10-30 Vdc	PNP/NPN NO-NC	4 wires	order No.	---	---	---	---
10-30 Vdc	PNP NO	3 wires	order No.	---	---	---	---
10-30 Vdc	PNP NC	3 wires	order No.	---	---	---	---
10-30 Vdc	NPN NO	3 wires	order No.	---	---	---	---
10-30 Vdc	NPN NC	3 wires	order No.	---	---	---	---
10-30 Vdc	PNP NO-NC	4 wires	order No.	---	---	---	---
10-30 Vdc	NPN NO-NC	4 wires	order No.	---	---	---	---
10-30 Vdc	NO-NC	2 wires	order No.	---	---	---	---
20-250 Vac/Vdc	NO	2 wires	order No.	---	---	---	---
20-250 Vac/Vdc	NC	2 wires	order No.	---	---	---	---
20-250 Vac	NO	2/3wires	order No.	---	---	---	---
10-30 Vdc	Analog 0-20 mA	3 wires	order No.	---	---	---	---
NAMUR amplifier	NAMUR	2 wires	order No.	IS-12-A20-S2 95B064180	IS-12-A20-03 95B064160	IS-12-C20-S2 95B064190	IS-12-C20-03 95B064170

Nominal Voltage	7,7 + 9 V DC	7,7 + 9 V DC	7,7 + 9 V DC	7,7 + 9 V DC
Residual Ripple	< 10%	< 10%	< 10%	< 10%
Hysteresis	< 10%	< 10%	< 10%	< 10%
Max. Output Current	< 3 mA (metal absent)	< 3 mA (metal absent)	< 3 mA (metal absent)	< 3 mA (metal absent)
Min. Output Current	< 1 mA (metal present)	< 1 mA (metal present)	< 1 mA (metal present)	< 1 mA (metal present)
Residual Current	---	---	---	---
Voltage Drop	---	---	---	---
Operation Led	---	---	---	---
Switching Frequency	2000 Hz	2000 Hz	2000 Hz	2000 Hz
Start Up Delay	---	---	---	---
Repeatability	< 3%	< 3%	< 3%	< 3%
Short Circuit Protection	Present (self-resetting)	Present (self-resetting)	Present (self-resetting)	Present (self-resetting)
Electric Protection	Against polarity reversal inductive loads	Against polarity reversal inductive loads	Against polarity reversal inductive loads	Against polarity reversal inductive loads
Temperature Limit	(-25 ... +60 °C)	(-25 ... +60 °C)	(-25 ... +60 °C)	(-25 ... +60 °C)
Protection Degree	IP67	IP67	IP67	IP67
Cable Length	---	2 m	---	2 m
Cable Section	---	2 x 0,25 mm ²	---	2 x 0,25 mm ²
Housing Material	Nickel-plated brass	Nickel-plated brass	Nickel-plated brass	Nickel-plated brass
Active face	LCP	LCP	LCP	LCP
Tightening torque	10Nm	10Nm	10Nm	10Nm
Weight - Cable Output	---	110 g	---	110 g
Weight - Connector Output	60 g	---	60 g	---

NAMUR M18

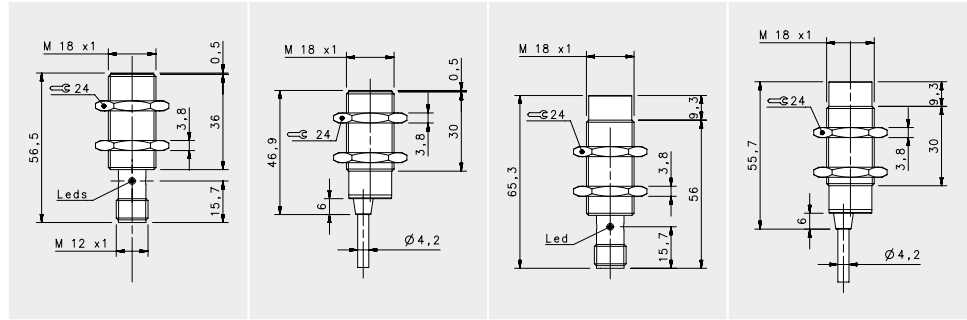

NAMUR

				FLUSH		NON FLUSH	
				M12 conn	cable	M12 conn	cable
				5mm	5mm	8mm	8mm
NOMINAL SWITCHING DISTANCE							
10-30 Vdc	PNP/NPN NO-NC	4 wires	order No.	---	---	---	---
10-30 Vdc	PNP NO	3 wires	order No.	---	---	---	---
10-30 Vdc	PNP NC	3 wires	order No.	---	---	---	---
10-30 Vdc	NPN NO	3 wires	order No.	---	---	---	---
10-30 Vdc	NPN NC	3 wires	order No.	---	---	---	---
10-30 Vdc	PNP NO-NC	4 wires	order No.	---	---	---	---
10-30 Vdc	NPN NO-NC	4 wires	order No.	---	---	---	---
10-30 Vdc	NO-NC	2 wires	order No.	---	---	---	---
20-250 Vac/Vdc	NO	2 wires	order No.	---	---	---	---
20-250 Vac/Vdc	NC	2 wires	order No.	---	---	---	---
20-250 Vac	NO	2/3wires	order No.	---	---	---	---
10-30 Vdc	Analog 0-20 mA	3 wires	order No.	---	---	---	---
NAMUR amplifier	NAMUR	2 wires	order No.	IS-18-A20-S2 95B064380	IS-18-A20-03 95B064360	IS-18-C20-S2 95B064390	IS-18-C20-03 95B064370

Nominal Voltage	7,7 +9 V DC	7,7 +9 V DC	7,7 +9 V DC	7,7 +9 V DC
Residual Ripple	< 10%	< 10%	< 10%	< 10%
Hysteresis	< 10%	< 10%	< 10%	< 10%
Max. Output Current	< 3 mA (metal absent)	< 3 mA (metal absent)	< 3 mA (metal absent)	< 3 mA (metal absent)
Min. Output Current	< 1 mA (metal present)	< 1 mA (metal present)	< 1 mA (metal present)	< 1 mA (metal present)
Residual Current	---	---	---	---
Voltage Drop	---	---	---	---
Operation Led	---	---	---	---
Switching Frequency	1000 Hz	1000 Hz	1000 Hz	1000 Hz
Start Up Delay	---	---	---	---
Repeatability	< 3%	< 3%	< 3%	< 3%
Short Circuit Protection	Present (self-resetting)	Present (self-resetting)	Present (self-resetting)	Present (self-resetting)
Electric Protection	Against polarity reversal inductive loads	Against polarity reversal inductive loads	Against polarity reversal inductive loads	Against polarity reversal inductive loads
Temperature Limit	(-25 ... +60 °C)	(-25 ... +60 °C)	(-25 ... +60 °C)	(-25 ... +60 °C)
Protection Degree	IP67	IP67	IP67	IP67
Cable Length	---	2 m	---	2 m
Cable Section	---	2 x 0,25 mm ²	---	2 x 0,25 mm ²
Housing Material	Nickel-plated brass	Nickel-plated brass	Nickel-plated brass	Nickel-plated brass
Active face	LCP	LCP	LCP	LCP
Tightening torque	30Nm	30Nm	30Nm	30Nm
Weight - Cable Output	---	145g	---	145g
Weight - Connector Output	95g	---	95g	---

NAMUR M30

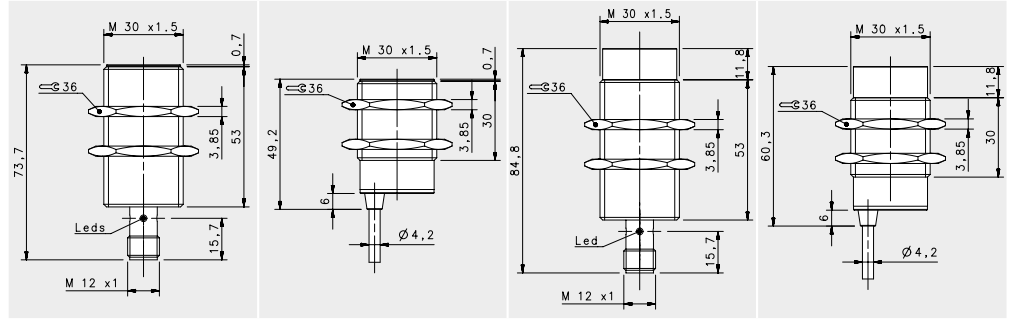

NAMUR

				FLUSH		NON FLUSH	
				M12 conn	cable	M12 conn	cable
				10mm	10mm	15mm	15mm
10-30 Vdc	PNP/NPN NO-NC	4 wires	order No.	---	---	---	---
10-30 Vdc	PNP NO	3 wires	order No.	---	---	---	---
10-30 Vdc	PNP NC	3 wires	order No.	---	---	---	---
10-30 Vdc	NPN NO	3 wires	order No.	---	---	---	---
10-30 Vdc	NPN NC	3 wires	order No.	---	---	---	---
10-30 Vdc	PNP NO-NC	4 wires	order No.	---	---	---	---
10-30 Vdc	NPN NO-NC	4 wires	order No.	---	---	---	---
10-30 Vdc	NO-NC	2 wires	order No.	---	---	---	---
20-250 Vac/Vdc	NO	2 wires	order No.	---	---	---	---
20-250 Vac/Vdc	NC	2 wires	order No.	---	---	---	---
20-250 Vac	NO	2/3 wires	order No.	---	---	---	---
10-30 Vdc	Analog 0-20 mA	3 wires	order No.	---	---	---	---
NAMUR amplifier	NAMUR	2 wires	order No.	IS-30-A20-S2 95B064630	IS-30-A20-03 95B064610	IS-30-C20-S2 95B064640	IS-30-C20-03 95B064620

Nominal Voltage	7,7 + 9 V DC	7,7 + 9 V DC	7,7 + 9 V DC	7,7 + 9 V DC
Residual Ripple	< 10%	< 10%	< 10%	< 10%
Hysteresis	< 10%	< 10%	< 10%	< 10%
Max. Output Current	< 3 mA (metal absent)	< 3 mA (metal absent)	< 3 mA (metal absent)	< 3 mA (metal absent)
Min. Output Current	< 1 mA (metal present)	< 1 mA (metal present)	< 1 mA (metal present)	< 1 mA (metal present)
Residual Current	---	---	---	---
Voltage Drop	---	---	---	---
Operation Led	---	---	---	---
Switching Frequency	500 Hz	500 Hz	500 Hz	500 Hz
Start Up Delay	---	---	---	---
Repeatability	< 3%	< 3%	< 3%	< 3%
Short Circuit Protection	Present (self-resetting)	Present (self-resetting)	Present (self-resetting)	Present (self-resetting)
Electric Protection	Against polarity reversal inductive loads	Against polarity reversal inductive loads	Against polarity reversal inductive loads	Against polarity reversal inductive loads
Temperature Limit	(-25 ... +60 °C)	(-25 ... +60 °C)	(-25 ... +60 °C)	(-25 ... +60 °C)
Protection Degree	IP67	IP67	IP67	IP67
Cable Length	---	2 m	---	2 m
Cable Section	---	2 x 0,25 mm ²	---	2 x 0,25 mm ²
Housing Material	Nickel-plated brass	Nickel-plated brass	Nickel-plated brass	Nickel-plated brass
Active face	LCP	LCP	LCP	LCP
Tightening torque	60Nm	60Nm	60Nm	60Nm
Weight - Cable Output	---	210 g	---	210 g
Weight - Connector Output	170 g	---	170 g	---

2 wires NAMUR

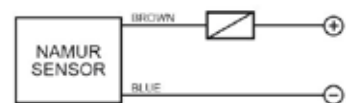

M12 2 wires NAMUR

