

版权所有, 侵权必究

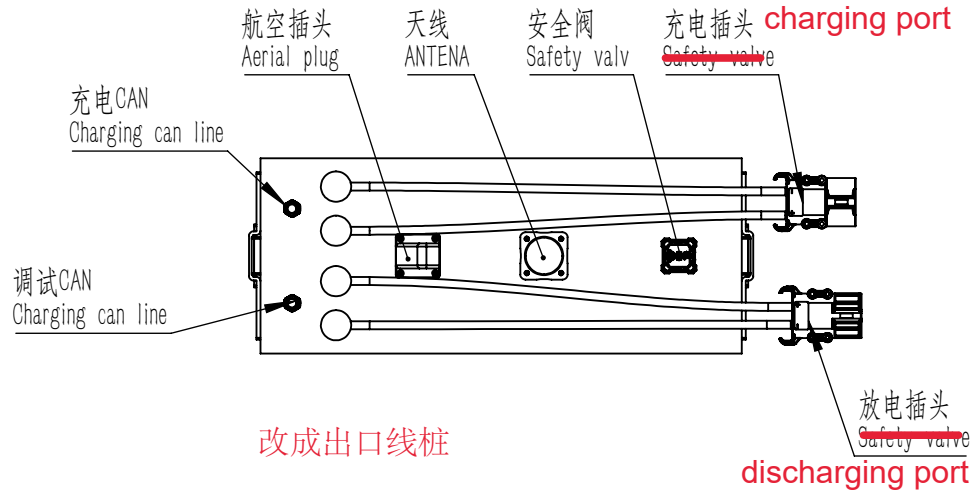
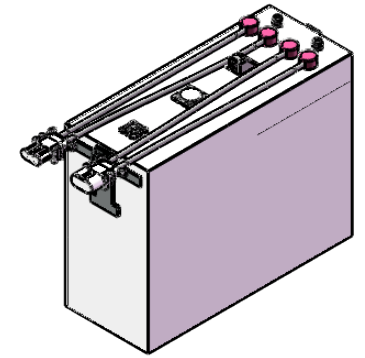
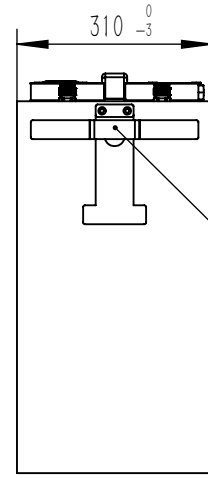
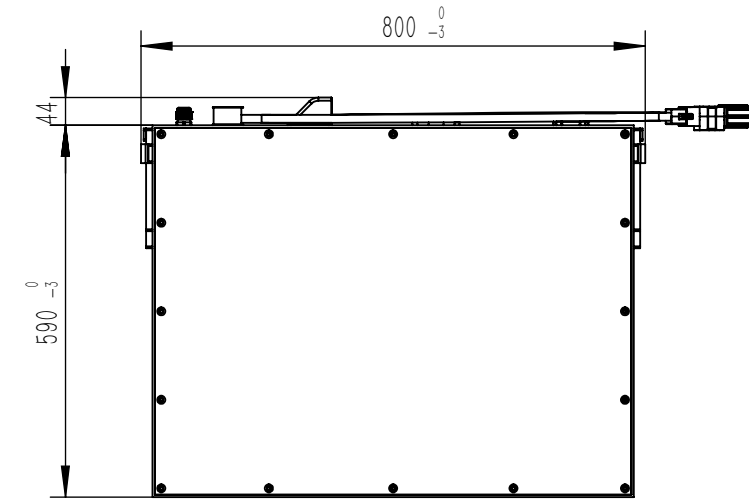

技术/工艺要求:

- (Technical/process requirements.)
- 箱体用钢板焊接而成, 焊接应牢固, 焊缝磨光;
(The box body is welded with steel plates. The welding should be firm and the weld should be polished.)
 - 确保箱体整体的平面度和垂直度, 表面光滑平整无毛刺;
(Ensure that the overall flatness and verticality of the box body, smooth and smooth surface without burrs.)
 - 接插件型号: 充电插头REMA320 放电插头 REMA320 线长0.8m,
(Connector model: Charging can lineREMA320 Safety valve REMA320 Line length 0.8m)
 - 表面喷塑处理, 颜色为按绿色 RAL6018, 厚度 0.5 ± 0.3 mm, 喷塑完确保各孔位无残渣;
(The surface is sprayed with green color and $0.5 + 0.3$ mm thickness. After spraying, no residue can be found i)
 - 产品总重 $360 \pm 5\%$ kg,
(The total weight of the product is $360 \pm 5\%$ kg.)
 - 未注尺寸按照GB1804_M级管控;
(Unmarked dimensions are controlled according to GB1804_M level.)

物料编号 MATE NUM.				产 品 名 称 TITLE	乌克兰- 25.6V 450AH 冷库带加热		安徽益佳通电池有限公司 Anhui EIKTO Battery Co., Ltd	
单位 UNIT	材 质 MATE.	重 量 MASS	数 量 QUAN.	mm	kg	PCS		
设计DR.	万君	标准化STD.		图样标记 MARK	版 本 VER.	视 角 ANGLE	图样名称 DRW NME.	客户确认图
校对CHK.		批准APPD.		比例 SCA.	篇 幅 SIZE		图样代号 DRW NUM.	
审核VERF.				工 艺 CRT.	日期DATE	2020/10/17	1:20	A4
					页 数 : 4 of 4			

篇幅
SIZE

A4