

图样代号
DRAW NUM

版本 REV.	日期 DATE	变更内容 DESCRIPTION	标记 MA.	设计 DR.	校对 CHK.	审核 VERF.	工艺 CRT.	标准化 STD.	批准 APPD.

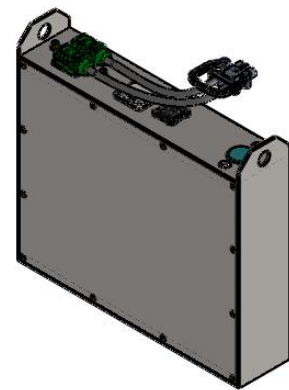
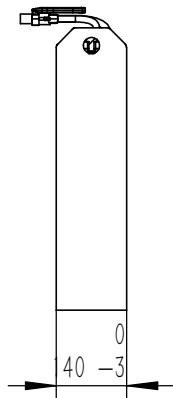
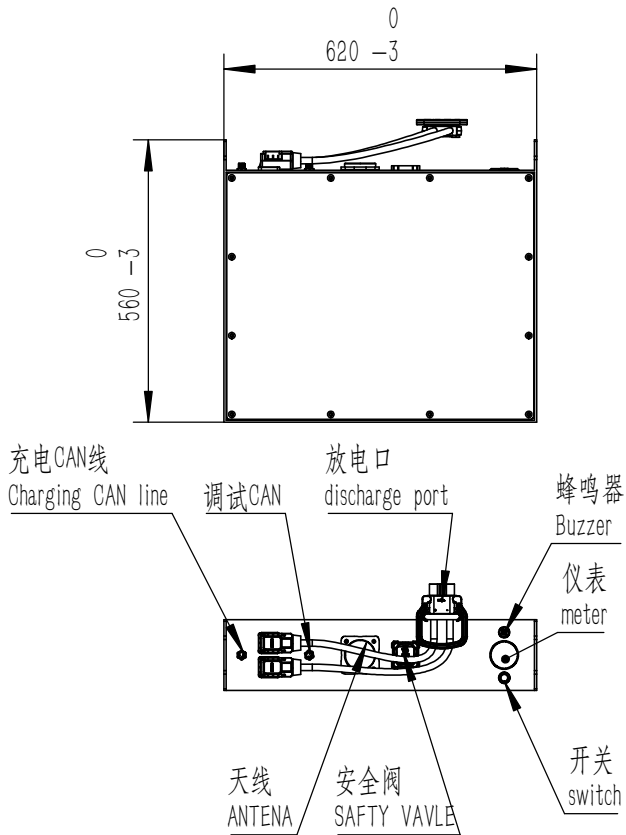

技术/工艺要求: Technical/process requirements.

- 箱体用钢板焊制而成, 焊接应牢固, 焊缝磨光; 确保箱体整体的平面度和垂直度, 表面光滑平整无毛刺;
The box body is welded by steel plate, the welding should be firm and the welding seam polished. Ensure that the overall flatness and verticality of the box body, smooth and smooth surface without burrs;
- 接插件型号: 已订单为准; 2. Connector model; subject to the order;
- 电缆线长度: 充放电电线根据实际订单来;
- 表面喷塑处理, 颜色色号根据订单颜色来, 厚度100~150um喷塑完确保各孔位无残渣;
4. Surface spraying treatment, The color number is based on the order color, the thickness is 100-150 um to ensure that there is no residue in each hole.
- 箱体总重80 ± 5%kg; 未注尺寸按照GB1804_M级管控;
5. The total weight of the box is 80 ± 5% kg. Unmarked dimensions are controlled according to GB1804_M level

物料编号 MATE NUM	单位 UNIT	材质 MATE.	重量 MASS	数量 QUAN.	产品名称 TITLE	定制	安徽益佳通电池有限公司 Anhui EIKTO Battery Co., Ltd	
mm			kg	PCS	定制	定制		
设计DR.	陈祖起	标准化STD.			图样标记 MARK	版本 VER.	视角 ANGLE	图样名称 DRW NME.
校对CHK.		批准APPD.				A01		客户确认图
审核VERF.					比例 SCA.	篇幅 SIZE		图样代号 DRW NUM.
工艺CRT.		日期DATE	2021-09-08		1:15	A4	页数: 1 of 1	