

<http://cnc.prom.ua/>



Комплектуючі системи ЧПУ

Наш сайт: <http://cnc.prom.ua/>

Тел: +380 (096)-665-71-06

+380 (098)-821-25-90

E-mail: [cncprom@ukr.net](mailto:cncprom@ukr.net)

# MD430

## stepper motor driver

(English Manual)

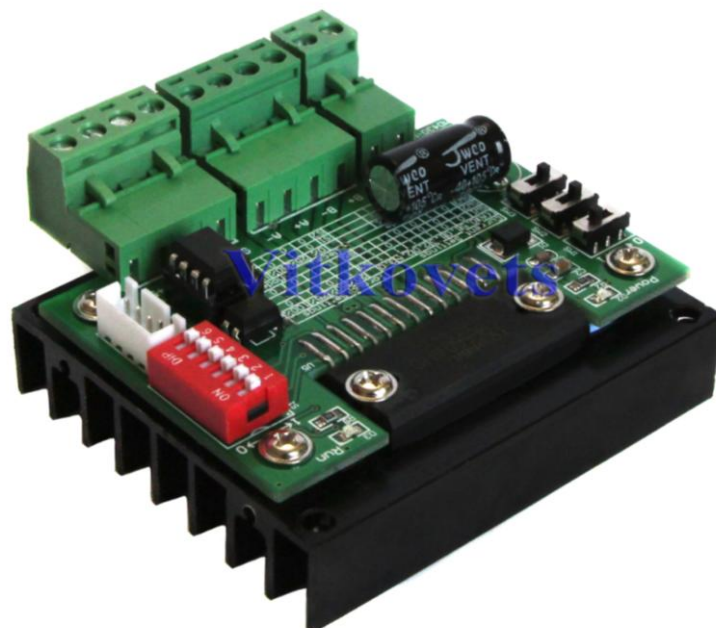

# 1. Introduction

## 1. Overview

MD430 is a compact single axis bipolar 3.0A/phase stepper motor micro stepping driver with step and direction inputs, DIP switch settable step mode (full, half, eight and sixteenth—S3/S4), torque (100%, 75%, 50%, 20%—S5/S6), work current (0-3A—SW1/SW2/SW3) and decay mode (0%, 25%, 50% and 100%).

## 2. Features

- 1) Single-chip motor driver for sinusoidal microstep control of stepping motors
- 2) Power on in indication led
- 3) 3Amps-34Volts (Supply voltages:12-34DC)
- 4) Full step, half step, eight step and sixteenth step(selection with dipo switches)
- 5) Torque (100%, 75%,50%, 20%)
- 6) Work Current (0-3A selection with SW1/SW2/SW3)
- 7) 4 Wire,6 Wire,8 Wire stepper motors can be used
- 8) Two phases bipolar driver
- 9) Easy wiring with standard screw terminals
- 10) Step frequency up to 100khz
- 11) Fuse protection on power supply rail (protects the board,but also your power supply and motor)

## 3. Applications

Suitable for all kinds of small and medium-sized automation equipment and apparatus For example, laser machines, laser engraving &cutting machine, laser subsurface engraving machine, laser handicraft cutting machine, (nonmetal materials) laser marking machine, laser seals engraving machine and photosensitive seal machine.

## 2. Electrical, mechanical and environmental Specifications

### 1. Electrical Specifications

Characteristics	Min	Typ	Max	Unit
Input voltage	12	24	34	V
Output current			3.5	A
VM Input current	7	10	16	mA
Pulse-frequency	0		100	KHz
Insulation resistance	500			MΩ

### 2. Use of the environment and parameters

Cooling	Natural cooling or forced air cooling	
Use environment	Occasions	Away from heating equipment, combustible gases and conductive dust, avoid dust, oil mist, corrosive gas, place too much humidity and strong vibration
	Temperature	0—+50°C
	Humidity	40—90%RH
	Vibration	5.9m/s <sup>2</sup> MAX
Storage temperature	-20°C ~ 80°C	
Weight	110g	

### 3. Install the machinery (unit: mm)

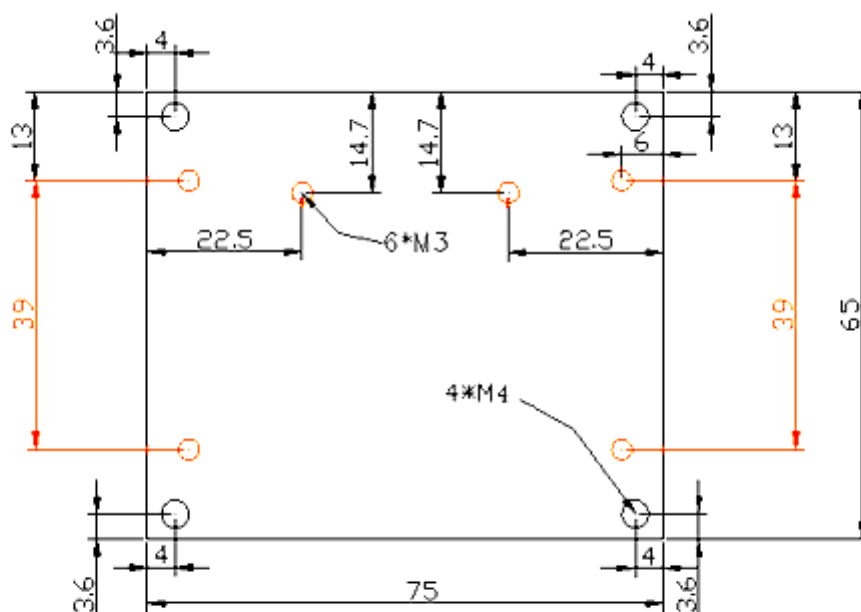

## 3. Connection to step motor

### 1. Port Description

#### 1) Control signal interface

Signal Name	Function
STEP	Pulse control signal: rising edge and effective; STEP HIGH 4 ~ 5V, low 0 ~ 0.5V. For reliable response to the pulse signal, pulse width should be greater than 5 $\mu$ s. If a +12 V or +24 V series resistance is required.
DIR	Direction signal: high/low signal in order to ensure reliable commutation motor, the direction of the signal pulse should be at least 5 $\mu$ s established. The initial direction of the motor to run the wiring for the motor, swap any one phase winding (such as A +, A-exchange) can change the motor direction of the initial run, DIR high 4 ~ 5V, 0 ~ 0.5V low.
EN	Enable signal: This input signal is used to enable or disable. EN low-level (or internal coupler conduction), the drive will cut off the electrical current of each phase of the motor in a free state, then pulse is not responding. When not required for this function, the enable signal terminal can be left vacant.
+5V	As STEP, DIR, EN common anode port

#### 2) Strong signal interfaces (Ban hot plug)

Signal Name	Function
G	GND
24V	Supply voltages:12-34DC
A+, A-	A phases
B+, B-	B phases

#### 3) Status Indication

Red LED indicator for power, when the drive is switched on, the LED lit; when the driver cut off the power, the LED turns off.

Green LED indicator for drive operation, when the drive receives an external pulse signal, the LED is lit; external pulse signal when the interrupt latency 200ms change the LED is off.

## 2. Control signal interface circuit

MD430 drive differential signal applied, single-end total of yin and yang interface, built-in high-speed optocoupler allows you to receive long-term drivers, and PNP open collector output circuit of the signal. The figure is the drive wiring diagram.

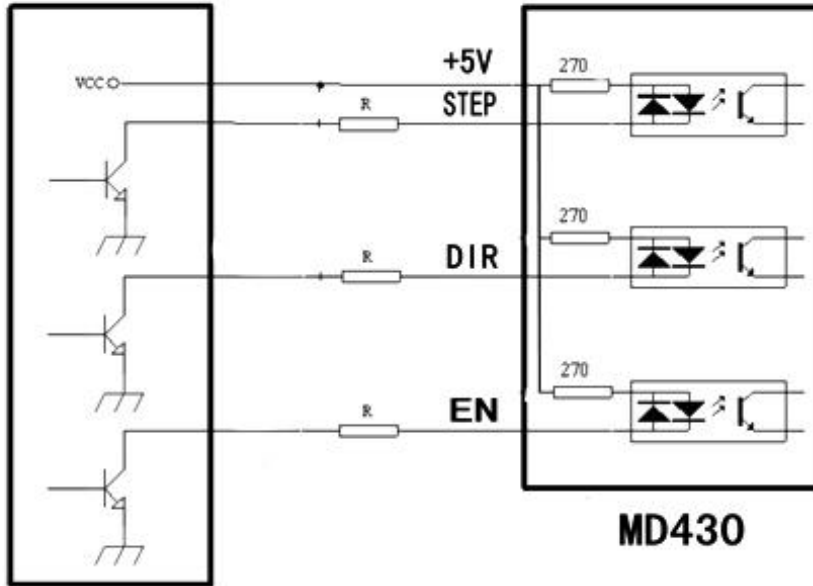

## 3. Control timing diagram

In order to avoid malfunction and error, STEP, DIR and EN should meet certain requirements, as show below:

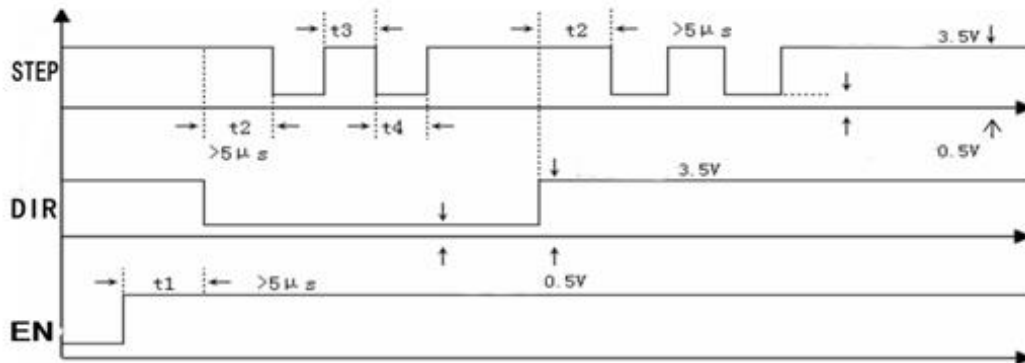

### Note:

- 1) t1: EN (enable signal) should be ahead of DIR at least  $5\mu s$ , identified as high. Under normal circumstances suggest vacant.
- 2) t2: DIR advance STEP falling  $5\mu s$ , high or low to determine its status.
- 3) t3: Pulse width of not less than  $2.5\mu s$ .
- 4) t4: Low-level width not less than  $2.5\mu s$ .

## 4. Wiring Requirements

- 1) Prevent interference, Recommend the use of shielded cable.
- 2) Control signal line and motor line not together, at least 10cm above to avoid system instability.
- 3) If a power supply for more than one drive should be connected in parallel at the power supply to not allow a

first one and then another chain connection.

- 4) Plug or unplug drive strong electric P2 terminals, the motor is stopped there are still charged high current flows through the coil, plug the P2 terminal will lead to great moments induced electromotive force will burn drive.
- 5) After the wire plus tin prohibited access terminals may damage the terminal.
- 6) Connection thread can not be exposed outside the terminal to prevent accidental short circuit and damage the drive.

## 4. DIP switch (current, segments, decay)

MD430 drive using six DIP switch segments accuracy, decay mode, semi-static flow, dynamic current three toggle settings:

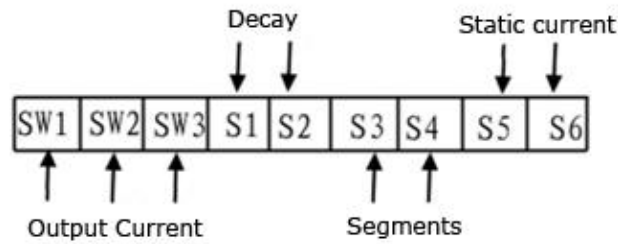

### 1. Current Settings:

1) Work (Dynamic) Current setting

Output Current	SW1	SW2	SW3
Default	0	0	0
1.0A	0	0	1
0.5A	0	1	0
1.5A	0	1	1
1.5A	1	0	0
2.5A	1	0	1
2.0A	1	1	0
3.0A	1	1	1

2) Static current setting

S5 S6 set Static current, the DIP switch on the left there is a status indicator 0 -> 1 through S5 S6 to set the static current and operating current. To S5: S6 = 0:1, for example, pulse train stopped about 0.4 seconds automatically reduced to about half of the current (actual value 60%), heat reduced to 36% in theory.

Static current	S5	S6	Note
20%	1	1	When the S5, S6 is 1,1, the static current is 20% of current value. Generally, the Static current is set to minimum to reduce motor and drive heat.
50%	0	1	
75%	1	0	
100%	0	0	

### 2. Segments Settings:

Segments	S3	S4	Note
1	0	0	S3 = 0, S4 = 0, drive segments number is 1,1.8° step angle motor turning circle, the whole step = 200 steps/rev. S3 = 0, S4 = 1,1.8° step angle motor turning circle, the whole step = 3200 steps / rev.
2	1	0	
8	1	1	
16	0	1	

### 3. Decay Mode

Decay Mode	S1	S2	Note
0%	0	0	Different electrical impedance matching of different decay modes, to eliminate the noise when the stepper motor lock, motor movement in the shake.
25%	1	0	
50%	0	1	
100%	1	1	

## 5. Power supply selection

Power supply voltage DC12V-34V can work, MD430 drive the best use of non-regulated DC power supply, can also be used step-down transformer + bridge + capacitive filter rectifier, capacitor desirable 6800uF or 10000uF. However, note should be rectified peak voltage ripple does not exceed 34V. Recommend the use of 12V-34V DC power supply to avoid power fluctuations over drive voltage range.

If you use a regulated switching power supply, switching power supply should be noted that the output current range to be set to maximum.

#### **Note:**

- 1) The wiring should pay attention not to reverse the positive and negative;
- 2) The best type of non-regulated power supply;
- 3) Use of non-regulated power supply, the supply current output drive capability should be greater than 60% of current can be set;
- 4) The use of regulated switching power supply, power supply output current should be greater than or equal to the drive current;
- 5) If electrical power is large enough, two drivers can share a power supply.

## 6. Matching the motor

Motor: 4,6,8-line two-phase, four-phase hybrid stepping motor, step angle of 1.8 degrees and 0.9 degrees can be applied.

Selected mainly based on the motor when the motor torque and current rating decision. Torque motor size determined primarily by size. Large size of the motor torque is relatively large; the current size of the primary and the inductance, high-speed performance of small induction motors, but a larger current.

### 1. Electrical wiring

For the 6,8-line stepper motor, connected in different coils of the motor performance quite different, as shown below:

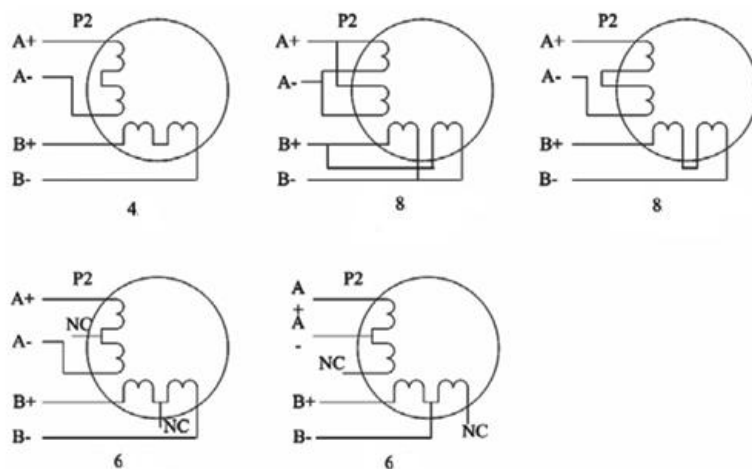

### 2. Input voltage and output current selection

#### 1) Supply voltage setting

In general, the higher the supply voltage, the greater the motor torque at high speed. High speed to avoid losing steps. On the other hand, the voltage is too high will lead to over-voltage protection, motor heat more, and may even damage the drive. When working at high voltage, low speed movement of the vibration will be larger.

#### 2) Output current setting

For the same motor, the current setting value, the greater the motor output torque, but the current is large motors and drives are also more serious heat. The size of the specific heat value not only with the current setting, but also with the exercise type and duration. The following is configured using the stepper motor rated current value as a reference, but the practical application of best value should be adjusted on this basis. In principle, such as low temperature ( $<40^{\circ}\text{C}$ ) is appropriate to increase the current settings as needed to increase the value of the motor output power (torque and speed response).

- Four-and six-wire motor speed mode: The output current is set equal to or slightly less than the motor rated current value;
- Six-lane high-torque motor mode: the output current is set to motor rated current 70%;
- Eight-wire electrical series connection: As the series resistance increases when the output current should be set to motor rated current 70%;
- Motor and eight-wire connection: output current can be set to 1.4 times the rated motor current.