

## Комплектуючі системи ЧПУ

Наш сайт: <http://cnc.prom.ua/>

Тел: +380 (096)-665-71-06

+380 (098)-821-25-90

E-mail: [cncprom@ukr.net](mailto:cncprom@ukr.net)

### 8060 2-Phase stepping Motor Driver



## 8060 2-Phase stepping Motor Driver

### Characteristics:

- 1.DC power input type:24V~80V
- 2.Output current:2~6A
- 3.Mircostepping:1(1.8°),1/2,1/4,1/8,1/16,1/32,1/64,1/128,1/256,1/5,1/10,1/25,1/50,1/125,1/250
4. Protect form : Overheated protect, lock automatic half current ,error connect protect
5. The maximum pulse rate is 200HZ.
6. Dimensions:147mm\*97mm\*30mm
7. Weight:<500g.
8. Working environment:Temperature-15~40°C Humidity<90%.

### I/O Ports:

- 1.VCC+:DC power positive pole

Note: Must guard against exceeding 70V, so as not to damage the module

- 2.GND:DC power cathode

- 3.A+,A-:Stepping motor one winding

- 4.B+,B-:Stepping motor other winding

- 5.CP +,CP -:Stepping pulse input+5V (Rising edge effective, rising edge duration >10μS)

- 6.CW +,CW -:Stepping motor direction input, voltage level touched off, high towards, low reverse

- 7.REST+,REST-: motor free

## The interface see

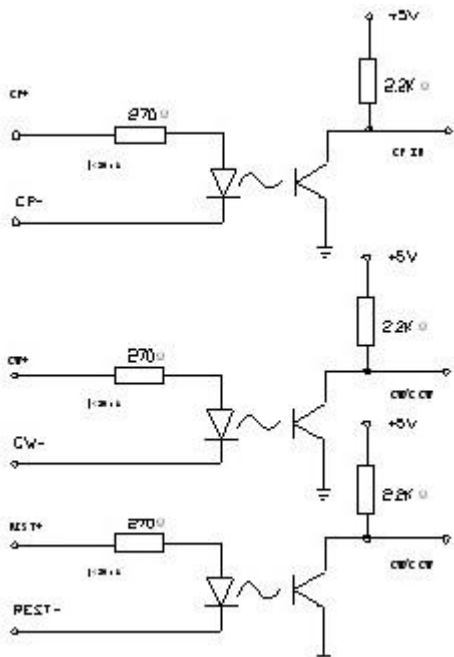

### NOTE:

1. When ambient temperature is high or working current over 3A, fix the module on big metal shell , or use axle flows fan dispels the heat, to make the module run reliably for a long time.
2. Half current automatically: if control machine not send out signal in half second, driver enter half current state of automatically for electricity saving, the phase current of the winding of the electric
3. The fault phase is protected: When the double-phase electrical machinery is connected with driver , users are apt to connect the phase by mistake, thus would damage the driver seriously. The protecting circuit is within this driver, when users connect by mistake, the driver will not be damaged, but the electrical machinery runs abnormally, shake, and output is small. Please check whether the wiring of electrical machinery is a mistake

Switch Choice: (“ON=0,OFF=1”)

### 1. Microstepping:

|       |     |     |     |      |      |      |       |       |     |      |      |      |       |       |
|-------|-----|-----|-----|------|------|------|-------|-------|-----|------|------|------|-------|-------|
| SW5   | 0   | 0   | 0   | 0    | 0    | 0    | 0     | 0     | 1   | 1    | 1    | 1    | 1     | 1     |
| SW6   | 0   | 1   | 0   | 1    | 0    | 1    | 0     | 1     | 0   | 1    | 0    | 1    | 0     | 1     |
| SW7   | 0   | 0   | 1   | 1    | 0    | 0    | 1     | 1     | 0   | 0    | 1    | 1    | 0     | 0     |
| SW8   | 0   | 0   | 0   | 0    | 1    | 1    | 1     | 1     | 0   | 0    | 0    | 0    | 1     | 1     |
| Micro | 1/2 | 1/4 | 1/8 | 1/16 | 1/32 | 1/64 | 1/128 | 1/256 | 1/5 | 1/10 | 1/25 | 1/50 | 1/125 | 1/250 |

### 2. Current:

|            |      |      |      |      |      |      |      |      |
|------------|------|------|------|------|------|------|------|------|
| SW1        | 0    | 1    | 0    | 1    | 0    | 1    | 0    | 1    |
| SW2        | 0    | 0    | 1    | 1    | 0    | 0    | 1    | 1    |
| SW3        | 0    | 0    | 0    | 0    | 1    | 1    | 1    | 1    |
| Current(A) | 2.00 | 2.57 | 3.14 | 3.71 | 4.28 | 4.86 | 5.43 | 6.00 |

### 3. Full current or half current choice:

SW4: 0 = Full current ; 1 = half current

### 4. Pulse choice:

Usually default setting is single pulse ↓

In the driver has a Jump:

Double pulse:

Single pulse:

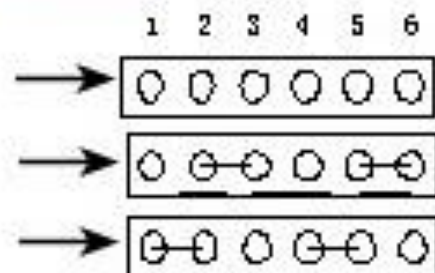

5.Sizes:

