



# CNC PROM



Інтернет - магазин комплектуючих для верстатів з ЧПУ

## MESA 7I33TA

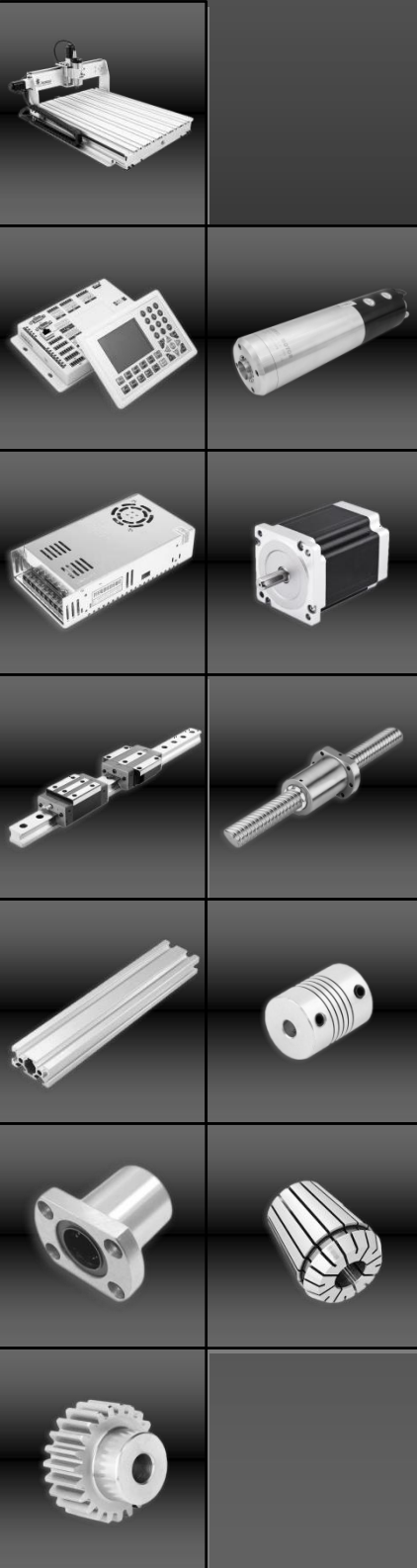
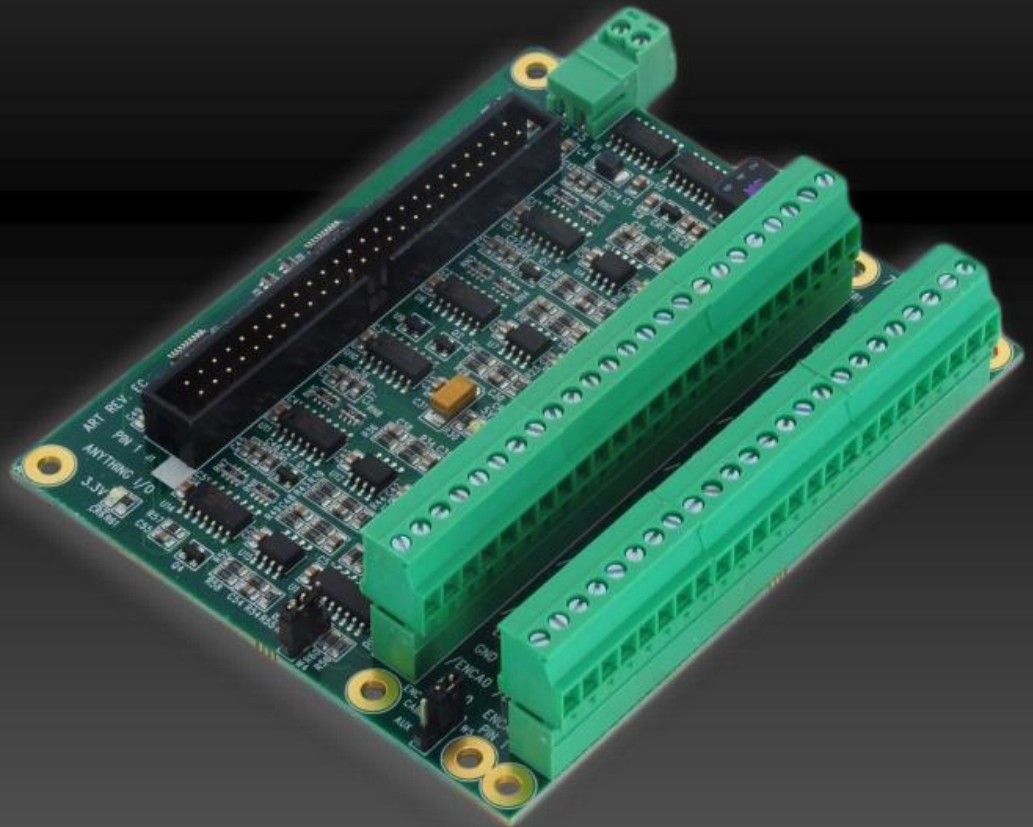

<https://cnc.prom.ua>



+38 (097) 100-30-30 +38 (099) 100-30-30 +38 (073) 100-30-30



[cncprom@ukr.net](mailto:cncprom@ukr.net)



+380966657106

# Table of Contents

GENERAL .....	1
DESCRIPTION .....	1
HARDWARE CONFIGURATION .....	2
DEFAULT JUMPER LOCATIONS .....	2
TTL/RS-422 ENCODER SELECTION .....	2
CONNECTORS .....	3
7I33 CONNECTOR LOCATIONS AND DEFAULT JUMPERS .....	3
7I33 CONNECTOR LOCATIONS AND DEFAULT JUMPERS .....	4
CONTROLLER CONNECTOR .....	5
AUX 5V POWER .....	5
50 PIN SERVO AMP/ENCODER CONNECTOR .....	6
TERMINAL BLOCK SERVO AMP/ENCODER CONNECTORS .....	7
OPERATION .....	9
PWM RATE .....	9
STEP RESPONSE .....	9
ENCODER INPUT CIRCUIT .....	9
MAXIMUM COUNT RATE .....	9
5V POWER .....	10
ENABLE INPUT .....	10
ENABLE OUTPUT .....	10
ANALOG OUTPUT .....	10
ANALOG CONNECTIONS .....	10
SPECIFICATIONS .....	11
DRAWINGS .....	12

C N C P R O M

# GENERAL

## DESCRIPTION

The 7I33 and 7I33TA are 4 axis analog servo interfaces intended for operation with MESA's Anything I/O cards when used for motion control applications. All 7I33 models take the PWM and direction signals from the Anything I/O card and converts them to +-10V analog output voltages for direct connection to analog input servo amplifiers.

The 7I33 also conditions the encoder input signals with input filters for TTL inputs or a RS-422 receivers for differential encoder inputs.

The controller connection is a 50 pin header that matches the pinout of the Mesa 4I27 motion controller (2 axis only) or the FPGA based Anything I/O cards. The 7I33 uses another 50 pin header for servo amp/encoder connections, while the 7I33TA uses Phoenix compatible 3.5 mm headers and comes with supplied pluggable terminal blocks.

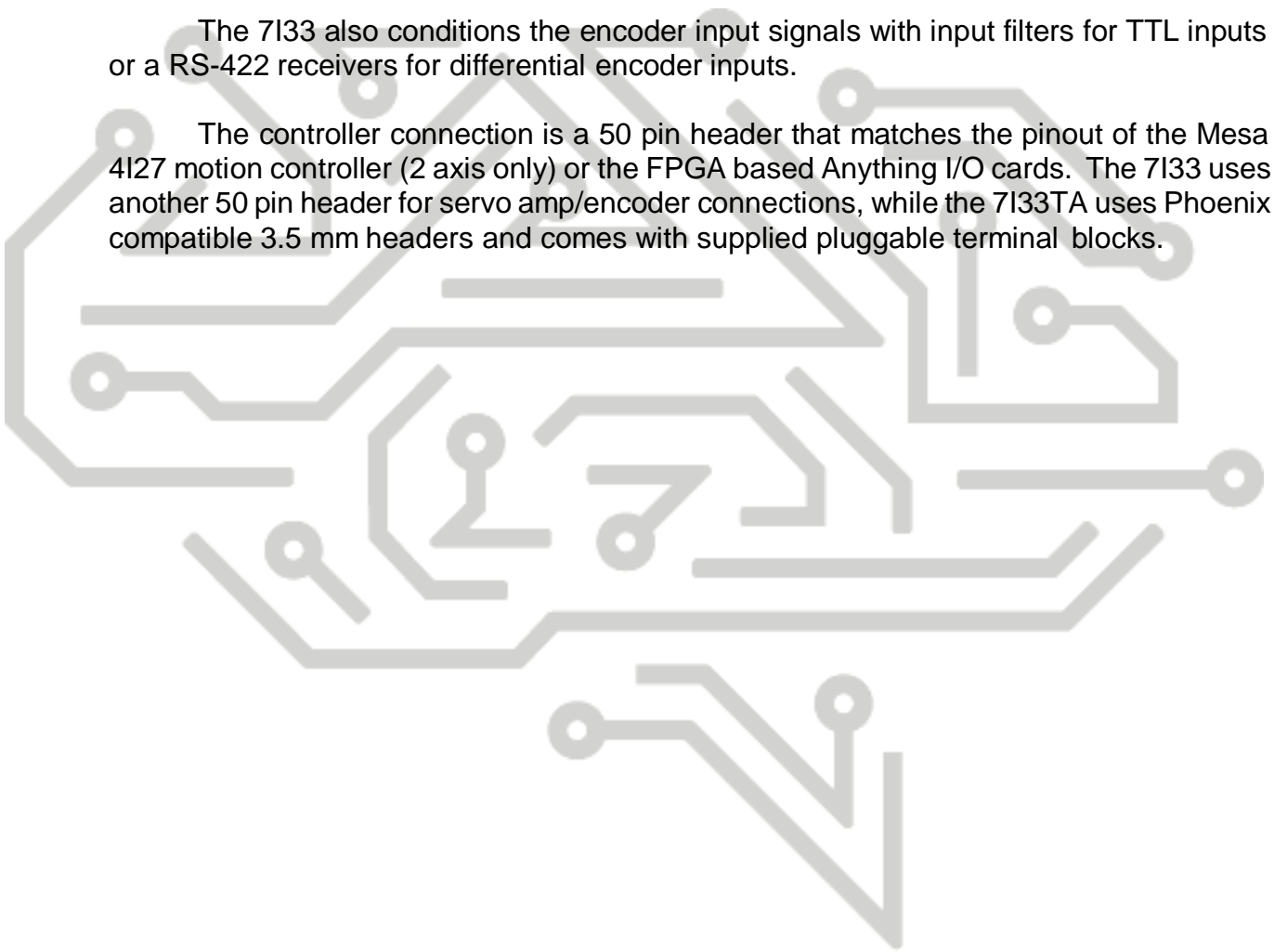

C N C P R O M

# HARDWARE CONFIGURATION

## GENERAL

Hardware setup jumper positions assume that the 7I33 card is oriented in an upright position, that is, with the 50 pin controller connector is on the left hand side,

## DEFAULT CONFIGURATION

JUMPER	FUNCTION	DEFAULT SETTING
W4	CH0 TTL/RS-422 SELECT	DOWN = TTL
W3	CH1 TTL/RS-422 SELECT	DOWN = TTL
W2	CH2 TTL/RS-422 SELECT	DOWN = TTL
W1	CH3 TTL/RS-422 SELECT	DOWN = TTL

## TTL/RS-422 ENCODER SELECTION

Each 7I33 channel has a selectable TTL or RS-422 (differential) encoder input conditioning. W1,W2,W3,and W4 determine the encoder input mode. When the jumpers are in the "DOWN" position, TTL inputs are selected, When the jumpers are in the "UP" position, RS-422 inputs are selected. W1 selects the input mode for channel 3 , W2 for channel 2, W3 for channel 1 and W4 for channel 0.

## AUX POWER ROUTING

On the 7I33TA an additional jumper allows the AUX POWER connector to supply power to the whole card or just to the encoder power connections. This jumper is W5. When W5 is in the 'UP' position, encoder power is connected to main 7I33TA 5V. If flat cable power is sufficient for running the 7I33TA and encoders, this is the suggested position. If flat cable power is not sufficient for running the encoders, it is suggested that 5V be applied to the AUX power connector and W5 be placed in the "DOWN" position.

### **IMPORTANT NOTE:**

*In TTL mode, 7I33 cards previous to revision D have series resistors in the output pins driving the controller card. FPGA card inputs with 3.3K pull-ups will result in poor noise immunity of the quadrature signals from the 7I33. If you are using TTL encoder inputs on a pre-rev D 7I33 card with a FPGA card having 3.3K pull-up resistors, it is best to remove the pull-up resistor SIP packages connected to the 7I33 from the FPGA card. This only affects TTL encoder inputs, not differential inputs.*

# CONNECTORS

## 7133 CONNECTOR LOCATIONS AND DEFAULT JUMPER POSITIONS

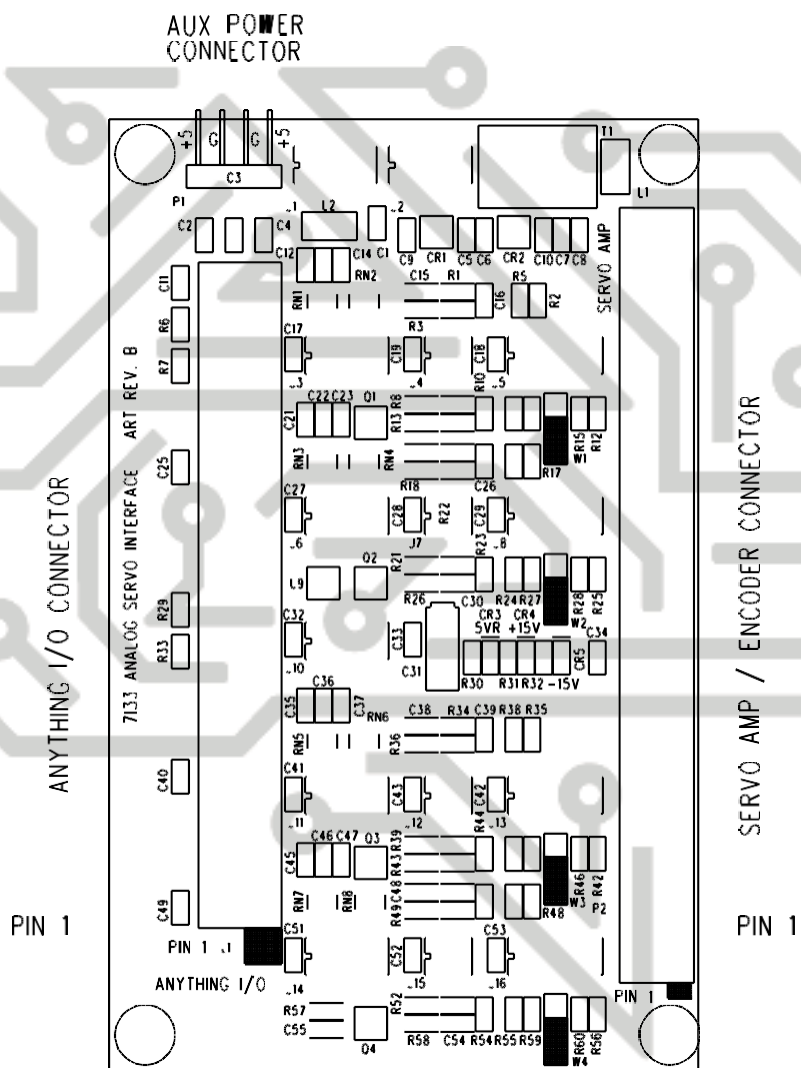

C N C P R O M

# 7133TA CONNECTOR LOCATIONS AND DEFAULT JUMPER POSITIONS

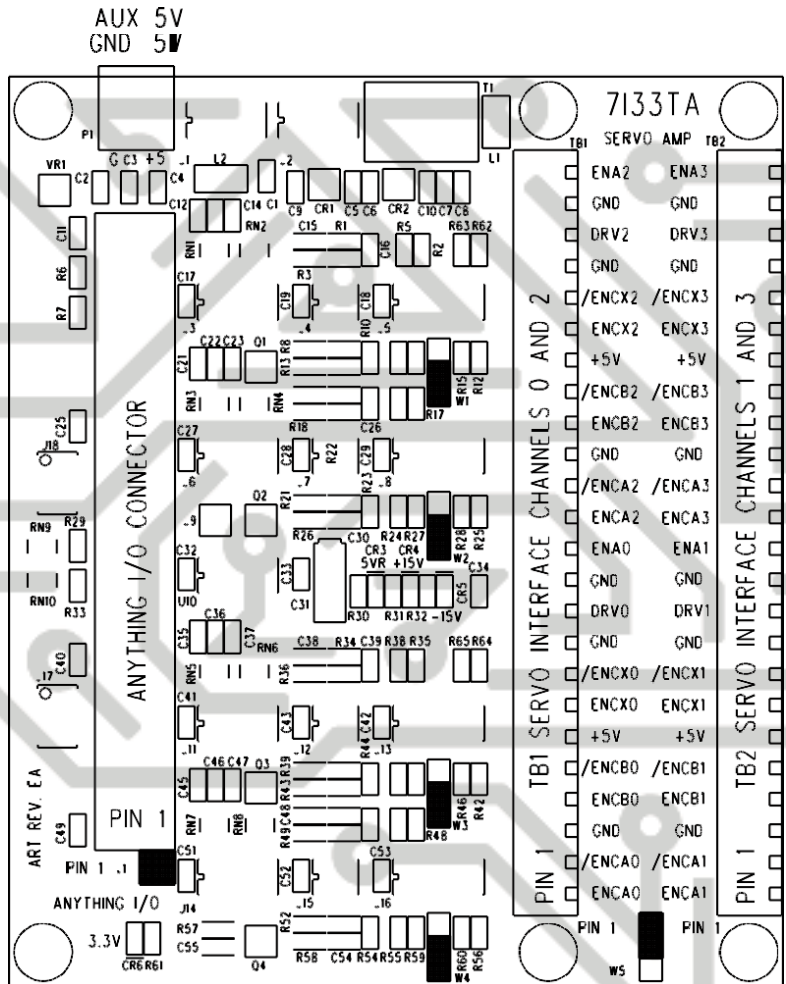

C N C P R O M

# CONNECTORS

## CONTROLLER CONNECTOR

50 pin header connector J1 connects to the anything I/O card/motion controller. This can be a male 50 pin header on the top of the 7I33 card or a female 50 conductor header on the bottom side of the 7I33 depending on 7I33 model. The controller connector pin-out matches the 4I34M, 4I65, 4I68, 7I43, 7I60, 5I20, 5I22, 5I23 (4 axis) pinouts. Controller connector pin-out is as follows:

PIN	FUNCTION	DIRECTION	PIN	FUNCTION	DIRECTION
1	QB1	FROM 7I33	25	QB3	FROM 7I33
3	QA1	FROM 7I33	27	QA3	FROM 7I33
5	QB0	FROM 7I33	29	QB2	FROM 7I33
7	QA0	FROM 7I33	31	QA2	FROM 7I33
9	QX1	FROM 7I33	33	QX3	FROM 7I33
11	QX0	FROM 7I33	35	QX2	FROM 7I33
13	PWM1	TO 7I33	37	PWM3	TO 7I33
15	PWM0	TO 7I33	39	PWM2	TO 7I33
17	DIR1	TO 7I33	41	DIR3	TO 7I33
19	DIR0	TO 7I33	43	DIR2	TO 7I33
21	/ENA1	TO 7I33	45	/ENA3	TO 7I33
23	/ENA0	TO 7I33	47	/ENA2	TO 7I33
			49	+5V PWR	TO 7I33

Note: all even pins are grounded.

## AUX 5V POWER

4 pin header P1 or 2 pin terminal block P1 can be used to supply 5V power to the 7I33 if the controller cable is too long and voltage drop too high. P1 has the following pinout:

PIN	FUNCTION (Rev. D and earlier)	PIN	FUNCTION (Rev. E and later)
1	5V	1	5V (Square pad)
2	GND	2	GND
3	GND		
4	5V		

# CONNECTORS

## 50 PIN SERVO AMP/ENCODER CONNECTOR

The 7133s servo amplifier / encoder connector (P2) is a 50 pin latching header. P2 has the following pinout:

PIN	FUNCTION	DIRECTION	PIN	FUNCTION	DIRECTION
1	GND		26	ENCA2	TO 7133
2	ENCA0	TO 7133	27	/ENCA2	TO 7133
3	/ENCA0	TO 7133	28	GND	
4	GND		29	ENCB2	TO 7133
5	ENCB0	TO 7133	30	/ENCB2	TO 7133
6	/ENCB0	TO 7133	31	VCC	FROM 7133
7	VCC	FROM 7133	32	IDX2	TO 7133
8	ENCX0	TO 7133	33	/IDX2	TO 7133
9	/ENCX0	TO 7133	34	GND	
10	GND		35	DRV2	FROM 7133
11	DRV0	FROM 7133	36	GND	
12	GND		37	ENA2	FROM 7133
13	ENA0	FROM 7133	38	ENCA3	TO 7133
14	ENCA1	TO 7133	39	/ENCA3	TO 7133
15	/ENCA1	TO 7133	40	GND	
16	GND		41	ENCB3	TO 7133
17	ENCB1	TO 7133	42	/ENCB3	TO 7133
18	/ENCB1	TO 7133	43	VCC	FROM 7133
19	VCC		44	ENCX3	TO 7133
20	ENCX1	TO 7133	45	/ENCX3	TO 7133
21	/ENCX1	TO 7133	46	GND	
22	GND		47	DRV3	FROM 7133
23	DRV1	FROM 7133	48	GND	
24	GND		49	ENA3	FROM 7133
25	ENA1	FROM 7133	50	GND	



# CONNECTORS

## TERMINAL BLOCK SERVO AMP/ENCODER CONNECTORS

The 7I33TAs servo amplifier / encoder connectors (TB1 and TB2) are 3.5MM 24 pin headers compatible with Phoenix pluggable terminal blocks (supplied with 7I33TA). TB1 (inner terminal block) pinout is as follows:

TB1 PIN	SIGNAL	DIRECTION	FUNCTION
1	ENCA0	TO 7I33TA	ENCODER 0 QUAD A
2	/ENCA0	TO 7I33TA	ENCODER 0 INVERTED QUAD A
3	GND	FROM 7I33TA	ENCODER 0 GROUND
4	ENCB0	TO 7I33TA	ENCODER 0 QUAD B
5	/ENCB0	TO 7I33TA	ENCODER 0 INVERTED QUAD B
6	+5V	FROM 7I33TA	ENCODER 0 5V POWER
7	ENCX0	TO 7I33TA	ENCODER 0 INDEX
8	/ENCX0	TO 7I33TA	ENCODER 0 INVERTED INDEX
9	GND	FROM 7I33TA	ANALOG 0 GROUND
10	DRV0	FROM 7I33TA	ANALOG 0 OUT
11	GND	FROM 7I33TA	SHIELD GND
12	ENA0	FROM 7I33TA	ENABLE 0 OUT
13	ENCA2	TO 7I33TA	ENCODER 2 QUAD A
14	/ENCA2	TO 7I33TA	ENCODER 2 INVERTED QUAD A
15	GND	FROM 7I33TA	ENCODER 2 GROUND
16	ENCB2	TO 7I33TA	ENCODER 2 QUAD B
17	/ENCB2	TO 7I33TA	ENCODER 2 INVERTED QUAD B
18	+5V	FROM 7I33TA	ENCODER 2 5V POWER
19	ENCX2	TO 7I33TA	ENCODER 2 INDEX
20	/ENCX2	TO 7I33TA	ENCODER 2 INVERTED INDEX
21	GND	FROM 7I33TA	ANALOG 2 GROUND
22	DRV2	FROM 7I33TA	ANALOG 2 OUT
23	GND	FROM 7I33TA	SHIELD GND
24	ENA2	FROM 7I33TA	ENABLE 2 OUT

# CONNECTORS

## TERMINAL BLOCK SERVO AMP/ENCODER CONNECTORS

TB2 (outer terminal block) pinout is as follows:

TB2 PIN	SIGNAL	DIRECTION	FUNCTION
1	ENCA1	TO 7I33TA	ENCODER 1 QUAD A
2	/ENCA1	TO 7I33TA	ENCODER 1 INVERTED QUAD A
3	GND	FROM 7I33TA	ENCODER 1 GROUND
4	ENCB1	TO 7I33TA	ENCODER 1 QUAD B
5	/ENCB1	TO 7I33TA	ENCODER 1 INVERTED QUAD B
6	+5V	FROM 7I33TA	ENCODER 1 5V POWER
7	ENCX1	TO 7I33TA	ENCODER 1 INDEX
8	/ENCX1	TO 7I33TA	ENCODER 1 INVERTED INDEX
9	GND	FROM 7I33TA	ANALOG 1 GROUND
10	DRV1	FROM 7I33TA	ANALOG 1 OUT
11	GND	FROM 7I33TA	SHIELD GND
12	ENA1	FROM 7I33TA	ENABLE 1 OUT
13	ENCA3	TO 7I33TA	ENCODER 3 QUAD A
14	/ENCA3	TO 7I33TA	ENCODER 3 INVERTED QUAD A
15	GND	FROM 7I33TA	ENCODER 3 GROUND
16	ENCB3	TO 7I33TA	ENCODER 3 QUAD B
17	/ENCB3	TO 7I33TA	ENCODER 3 INVERTED QUAD B
18	+5V	FROM 7I33TA	ENCODER 3 5V POWER
19	ENCX3	TO 7I33TA	ENCODER 3 INDEX
20	/ENCX3	TO 7I33TA	ENCODER 3 INVERTED INDEX
21	GND	FROM 7I33TA	ANALOG 3 GROUND
22	DRV3	FROM 7I33TA	ANALOG 3 OUT
23	GND	FROM 7I33TA	SHIELD GND
24	ENA3	FROM 7I33TA	ENABLE 3 OUT

# OPERATION

## PWM RATE

The 7133 is meant to operate with PWM rates from 100 KHz to 10 MHz. Operation at lower PWM rates will result in excessive output ripple . When used with *SOFTDMC* firmware, it is best to set the PWM rate to the maximum (192 KHz). If the motion control firmware is capable of generating interleaved PWM, that option should be enabled to minimize output ripple. When used with HostMot2 firmware, the PWM generators PDM option should be chosen with a frequency of 6 MHz. This will result in the best ripple and linearity.

## STEP RESPONSE

The 7133 PWM filter has an approximate 150 uSec time constant. This value is selected as a compromise between output ripple and settling time. This is much faster than most controlled devices and will not normally have any effect on loop stability or performance. The 7133 can be assembled with different components if necessary to change this time constant.

## ENCODER INPUT CIRCUIT

The 7133 input circuit is different depending on whether TTL or RS-422 encoder types have been selected.

In TTL mode the input circuit on the encoder A,B, and Index inputs (ENCA, ENCB and ENCX) consists of a RC filter followed by a Schmitt trigger. This helps to reject spike noise on the encoder lines. The input circuit inverts the signals, so, for example, an active high index signal will be active low at the controller interface.

In RS-422 mode, the input consists of true and inverted signals for each A,B and index signal (ENCA, /ENCA, for A, ENCB, /ENCB for B and ENCX,/ENCX for index). The RS-422 inputs have a 132 Ohm termination resistor across each true/inverted signal pair and a 26LS32 RS-422 differential receiver.

## MAXIMUM COUNT RATE

In TTL mode, the input RC filter limits the maximum encoder input frequency to approximately 1 MHz. This corresponds to 4 million counts per second with most quadrature counters (4X mode). The maximum input frequency may be lower with encoders that have high value (>1K Ohm) pull-up resistors on open collector outputs.

In RS-422 mode, maximum encoder input frequency is 10 MHz, giving a maximum count rate of 40 million counts per second. Maximum count rate may be further limited by encoder counter limitations or rate filters.

## 5V POWER

The 7I33 requires ~150 mA of 5V power for operation. Encoder power can also be supplied from the 7I33's 5V source. Power for the 7I33 is normally supplied from pin 49 of the 50 conductor controller cable, but can also be supplied via P1.

## ENABLE INPUT

Each 7I33 channel has an active low TTL level enable input. When this input is high, the corresponding AOUT is forced to 0V regardless of the state of the PWM and direction inputs. A pullup resistor keeps the enable input high if the controller connection is lost.

## ENABLE OUTPUT

Each 7I33 channel has an 5V CMOS active high enable output available on the SERVO AMP / ENCODER connector. These signals are the logical inversion of the Enable inputs.

## ANALOG OUTPUT

The analog outputs (DRV 0 through 3) of the 7I33 swing from -10 v to +10V. Positive outputs are generated when the DIR input is high, and negative outputs when DIR is low. A 50 % duty cycle PWM signal will generate a 5V output. This mode of operation is often referred to as sign-magnitude.

Due to power supply limitations, The 7I33 has limited DC output drive capability and should not have loads of less than 5K Ohms on its analog outputs.

## ANALOG DRIVE CONNECTIONS

Normally motor drives have differential inputs to reduce noise on their analog inputs. To make the best use of this feature, the 7I33 should be wired to the drive with shielded twisted pair wiring. Different drives have different input signal names, but typical connections are 7I33 DRV to drive INPUT+, 7I33 GND (adjacent to DRV) to drive INPUT- (these two signals are the twisted pair). The twisted pair shield should be terminated at the 7I33 ground and left un-terminated at the drive end. The drives input ground should be returned to the same ground as the controller or PC,

C N C P R O M

# SPECIFICATIONS

	MIN	MAX	UNITS
5V POWER SUPPLY	4.75	5.25	VDC
5V POWER CONSUMPTION (no external load)	---	100	mA
ANALOG OUTPUT VOLTAGE	+9.7	+10.3	V
MINIMUM AOUT LOAD RESISTANCE	5K	---	Ohm
OUTPUT RIPPLE @ 100 KHZ PWM	---	2	% FS
OUTPUT RIPPLE @ 6 MHz PDM	---	.2%	% FS
LINEARITY (PWM or PDM)	---	.2%	% FS
ENCODER FREQUENCY (TTL)	DC	1	MHz
ENCODER FREQUENCY (RS-422)	DC	10	MHz
OPERATING TEMP.	0	+70	°C
OPERATING TEMP. (-I version)	-40	+85	°C
OPERATION HUMIDITY	0	95%	NON-COND

C N C P R O M

# DRAWINGS

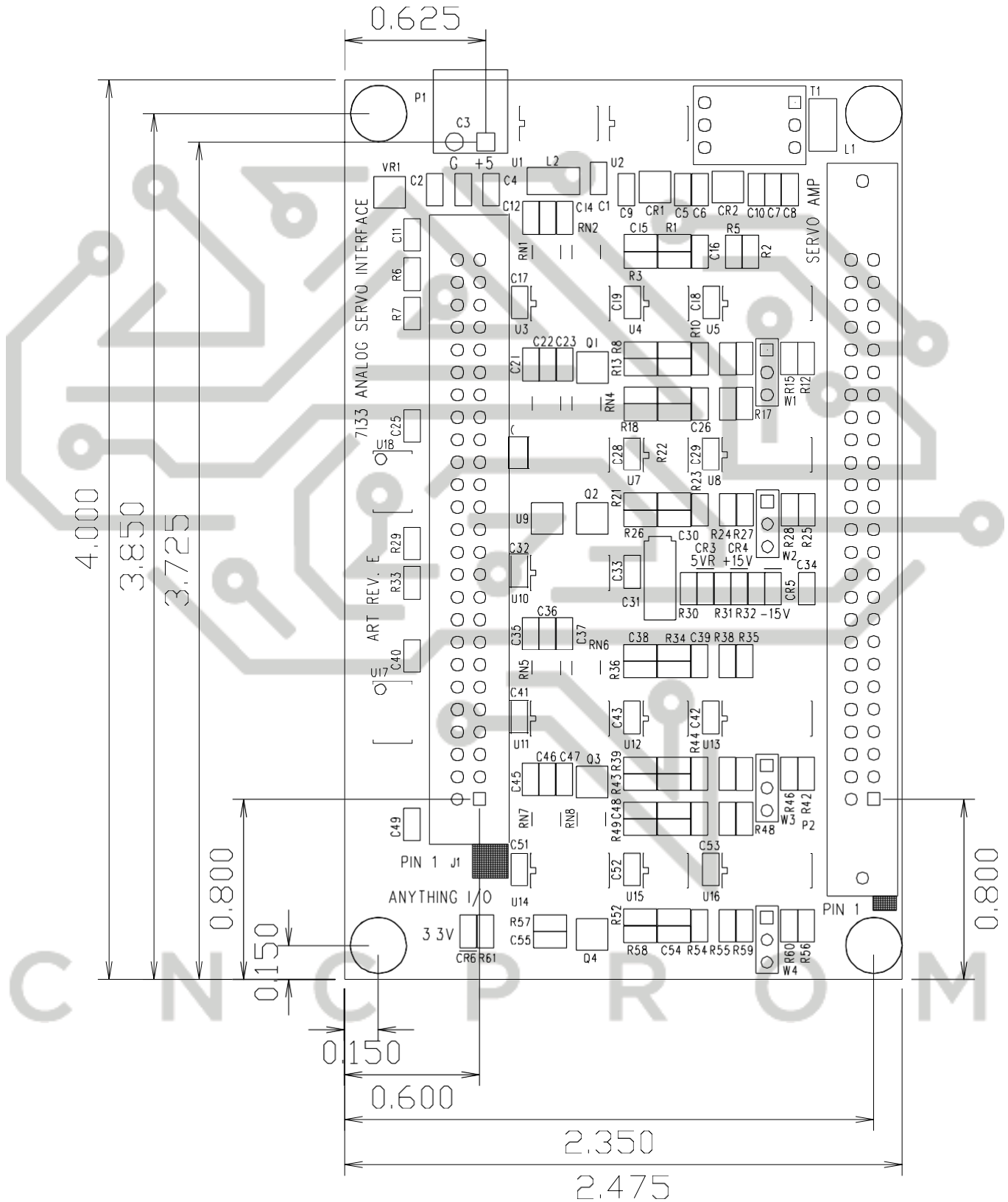

# DRAWINGS

