



# CNC PROM

Інтернет - магазин комплектуючих для верстатів з ЧПУ

 <http://cnc.prom.ua>

 +38 (097)-100-30-30

 +38 (098)-821-25-90

 [cncprom@ukr.net](mailto:cncprom@ukr.net)

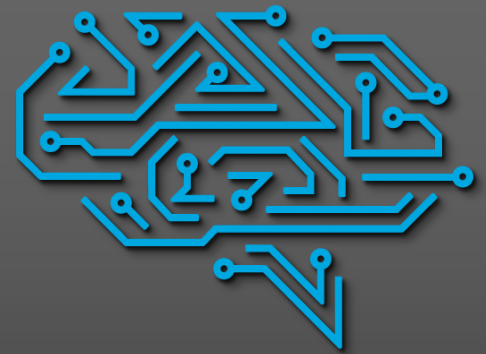

C N C P R O M

## C25-Smooth Stepper LPT Board Rev. 5

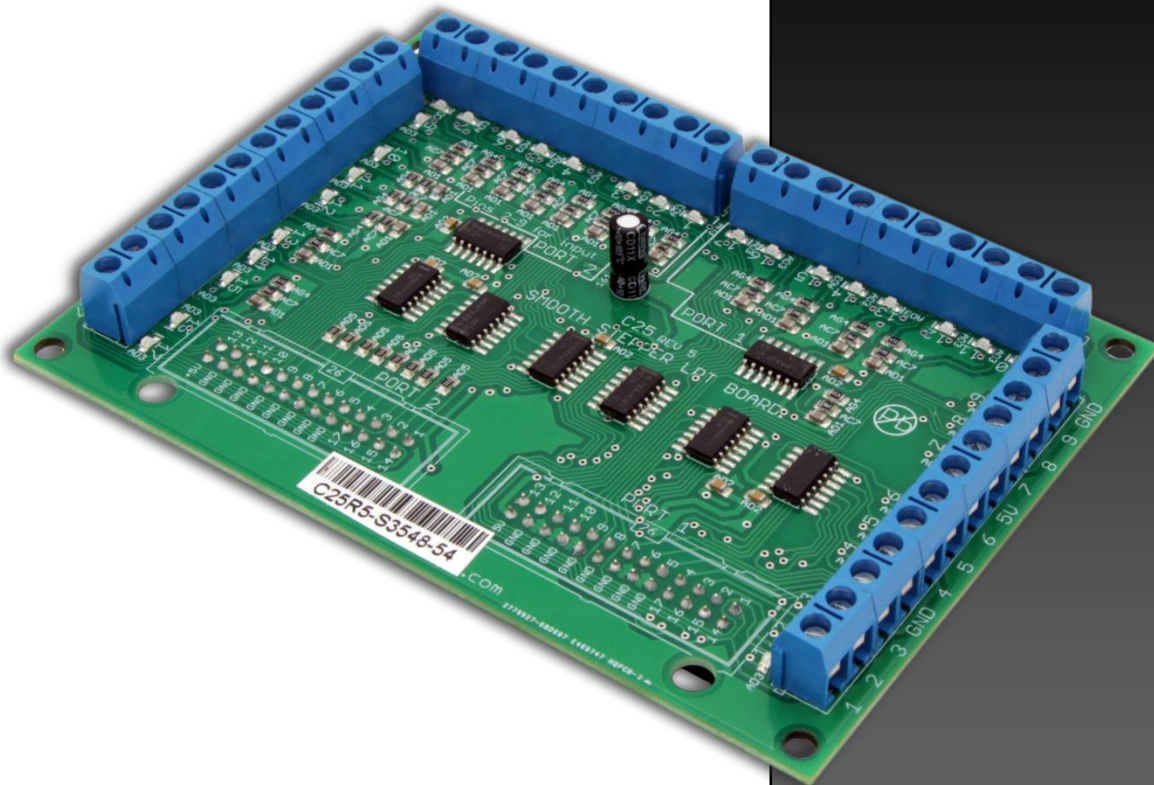

---

## USER'S MANUAL

### TABLE OF CONTENTS

<b>Contents</b>	<b><u>Page #</u></b>
<b>1.0 FEATURES.....</b>	<b>1</b>
<b>2.0 SPECIFICATIONS .....</b>	<b>1</b>
<b>FUNCTIONAL BLOCK DIAGRAMS.....</b>	<b>2</b>
<b>Inputs 10, 11, 12 13 and 15 (Port 1 and Port 2) Schematic .....</b>	<b>2</b>
<b>Inputs 2-9 (Port 2) Schematic .....</b>	<b>2</b>
<b>4.0 POWERING THE BOARD .....</b>	<b>3</b>
<b>WIRING DIAGRAMS.....</b>	<b>3</b>
<b>Connecting Switches or push button .....</b>	<b>4</b>
<b>Connecting NPN sensors (For any input).....</b>	<b>4</b>
<b>Connecting PNP sensors (For any input) .....</b>	<b>6</b>
<b>6.0 DIMENSIONS.....</b>	<b>7</b>

---

---

## 1.0 FEATURES

- **34 Inputs and Outputs on 2 ports.**
- **Full access to all the pins of the Smooth Stepper Board.**
- **Connects directly to the Smooth Stepper (from Warp9).**

The board is provided with sockets that allow the Smooth Stepper Board to be plugged directly into this board. No ribbon cables required. When using the Smooth Stepper board there is no need to use an additional power supply to power the board. It will draw power from the Smooth Stepper board.
- **Built-in Passive Low Pass Filters for the all inputs.**

This board includes low pass filters to reduce the effect of the noise from the drivers or other devices over the input signals.
- **All TTL 5VDC signals.**
- **Input and output pins with close by ground connections.**

Forget about grounding problems. Easily connect your pin by using your close by ground connection. No need to be an electronics expert to ground all your stuff.
- **Screw-On connections for all terminals.**
- **Status LEDs on all inputs and output connections.**

## 2.0 SPECIFICATIONS

DIGITAL INPUT SPECIFICATIONS	
Numbers of inputs	5 on Port1, 13 on Port2
On-state voltage range	3.5 to 5V DC
Maximum off-state voltage	Approx. 1.5V
Type	Active High

DIGITAL OUTPUT SPECIFICATIONS	
Number of outputs	12 on Port1, 4 on port2
Maximum output voltage	(5V power supply voltage) +0.5V
Maximum off-state voltage	0.33 V

---

## FUNCTIONAL BLOCK DIAGRAMS

### Inputs 10, 11, 12 13 and 15 (Port 1 and Port 2) Schematic

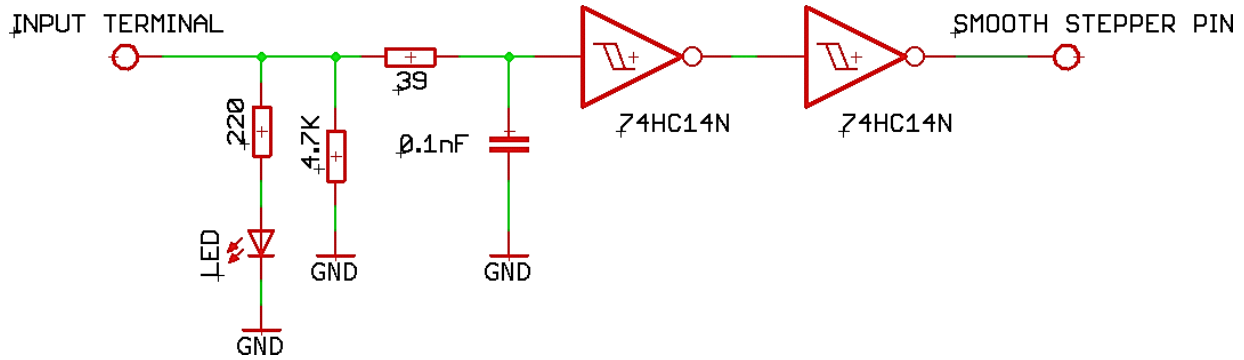

Simplified functional block diagram

**Note:** The Smooth Stepper includes a Schmitt Trigger in those input pins.

### Inputs 2-9 (Port 2) Schematic

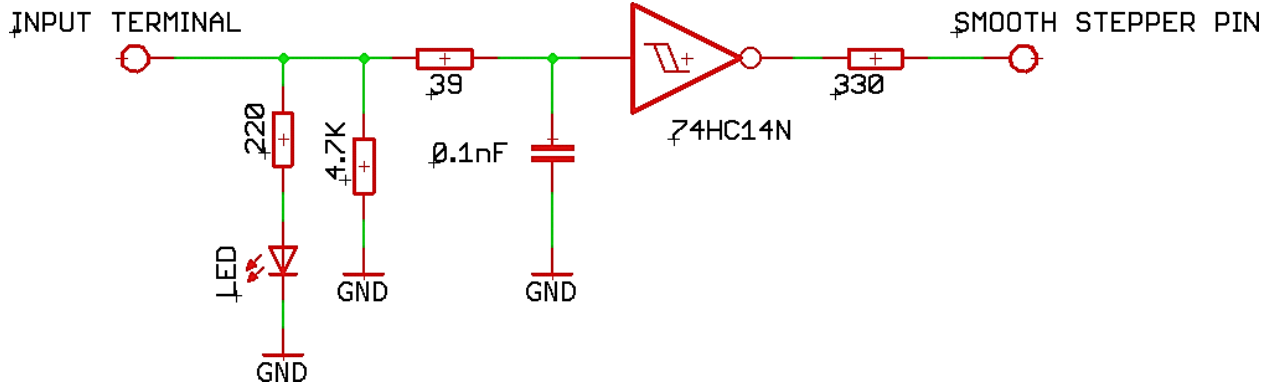

Using an RC Low Pass filter followed by a Schmitt Trigger gate will reduce the effect of the noise from driver or other devices. This eliminates the high frequency components of the noise generating a fast changing signal.

### Outputs 1, 14, 16 and 17 (Port 1 and 2) and outputs 2-9 (port 1).

All those pins are directly wired to the C25 output terminals.



---

## Connecting Switches or push button.

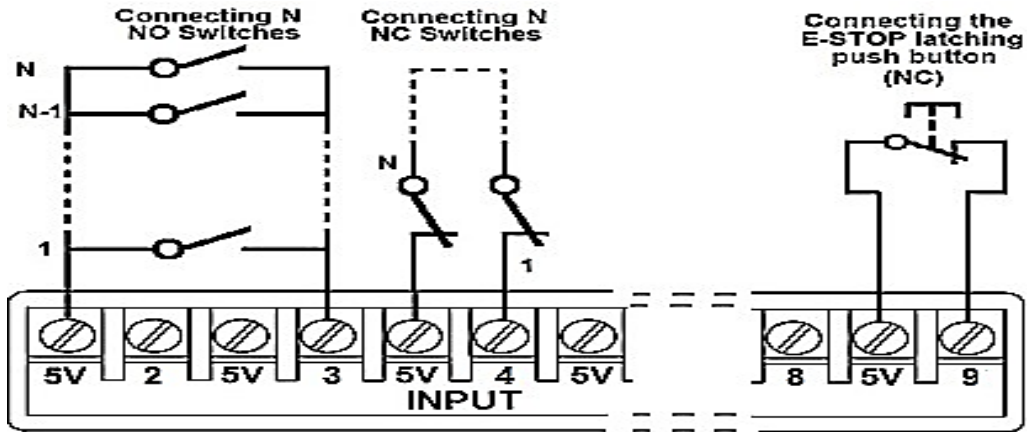

**WIRING DIAGRAM TO CONNECT SWITCHES**

**Note:** When you measure the voltage of the pin in the air after the resistor, you may find the voltage to be higher, but once it interacts with the pull-down in the input pin of the breakout board, it stabilizes to +5vdc.

## Connecting NPN sensors (For any input)

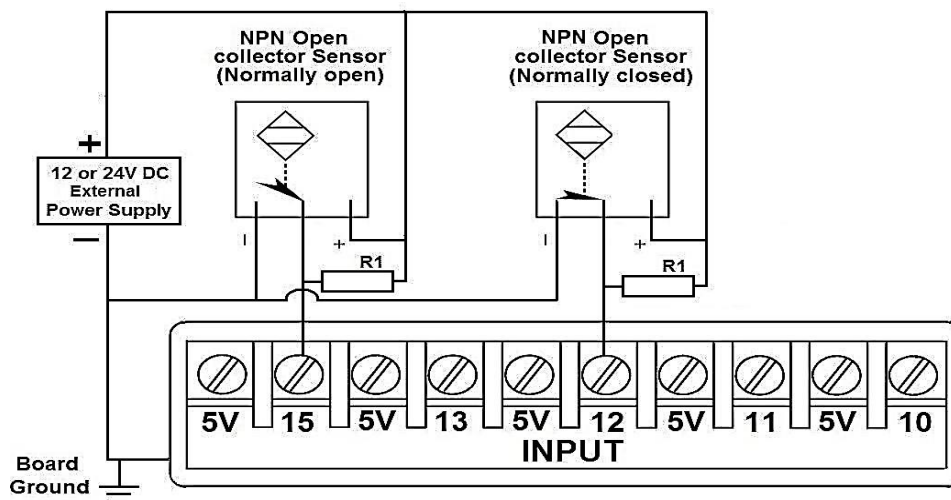

**Wiring diagram to connect NPN open collector proximity sensors**

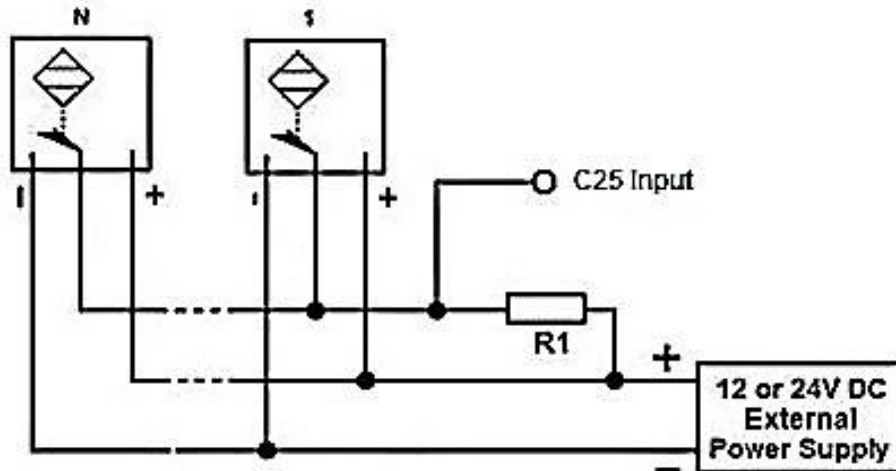

**WIRING DIAGRAM TO CONNECT IN PARALLEL NPN OPEN COLLECTOR PROXIMITY SENSORS**

Connecting NPN open collector proximity sensor with the C25	
R1 Value (12V)	R1 Value (24V)
Approx. 10KΩ	Approx. 25KΩ

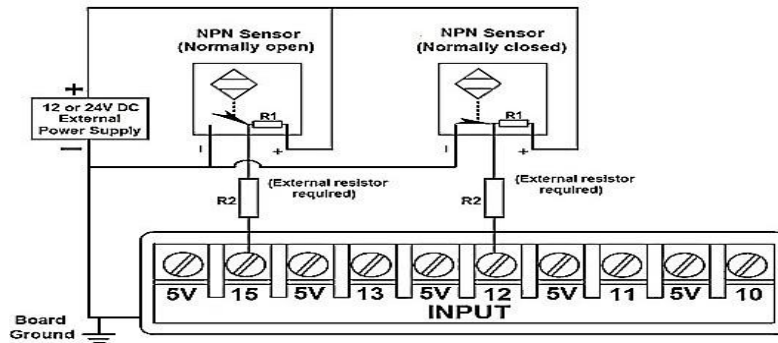

**Wiring diagram to connect NPN proximity sensors with internal pull up resistor**

Some NPN proximity sensors have an internal pull-up resistor (R1). It is necessary to know its value in order to safely connect the sensor with the BOB. Follow this recommendation:

Connecting NPN open collector proximity sensor with the C25	
(R1+R2) Value (12V)	(R1+R2) Value (24V)
Approx. 10KΩ	Approx. 25KΩ

## CALCULATING THE R1 VALUE

Note: Rx is the unknown resistor value.

Where:

$V_{EX}$  is the external power supply voltage

V is the voltage across the R resistor

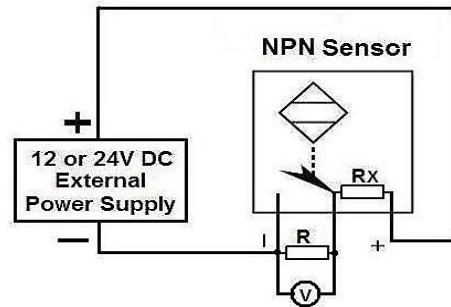

$$R_X = V_{EX} \cdot (R/V) - R \quad (1)$$

A voltmeter is required to calculate the internal resistor value (Rx). Do the connection as shown in the figure above and do the calculations using the equation (1).

**Note.** R value has to be known to do this operation. A 4.7KOhm@1/2W is recommended.

Connecting PNP sensors (For any input)

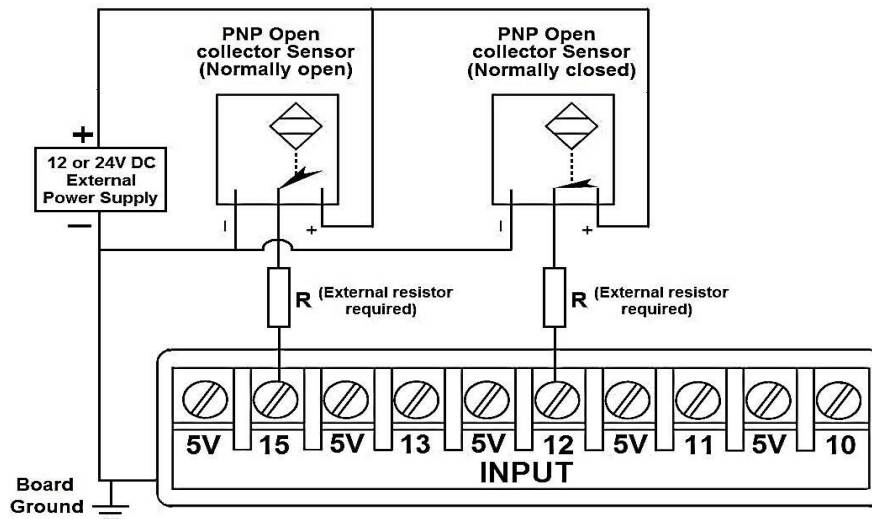

Wiring diagram to connect PNP proximity sensors

Connecting PNP proximity sensor with the C25	
R Value (12V)	R Value (24V)
Approx. 10KΩ	Approx. 25KΩ



## 6.0 DIMENSIONS

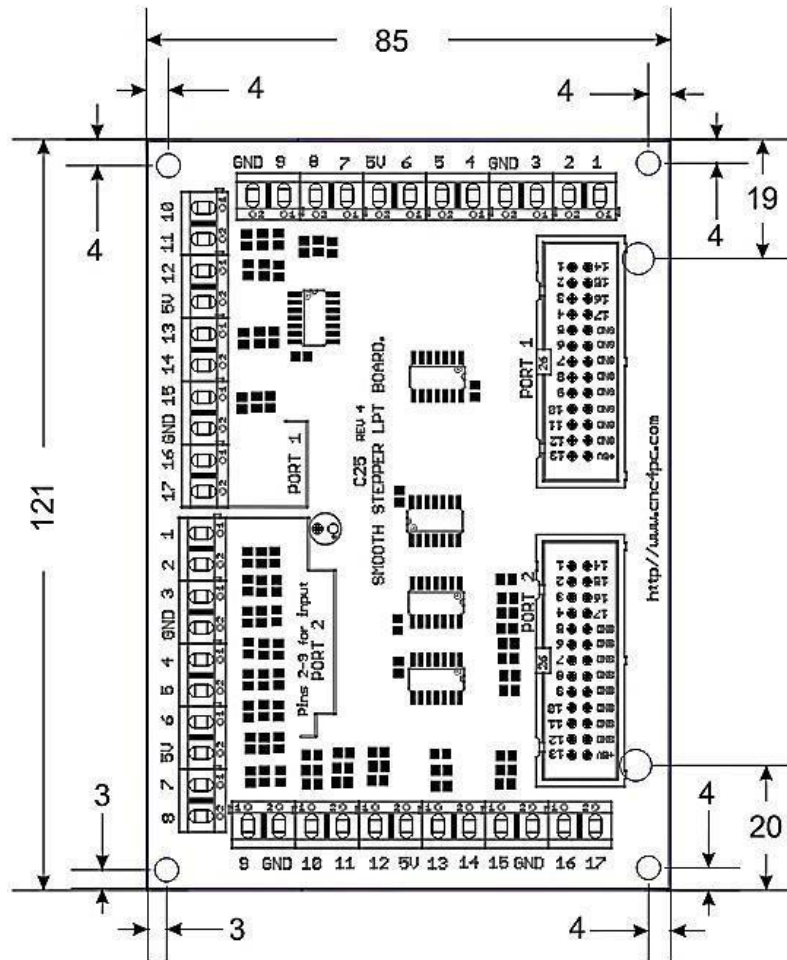

All dimensions are in Millimeters.  
**Fixing holes (3.8mm).**

## DISCLAIMER

Use caution. CNC machines can be dangerous machines. Neither DUNCAN USA, LLC nor Arturo Duncan are liable for any accidents resulting from the improper use of these devices. This product is not a fail-safe device and it should not be used in life support systems or in other devices where its failure or possible erratic operation could cause property damage, bodily injury or loss of life.