Contents

1. Brief Introduction.....	1
1.1 Overview.....	1
1.2 Features.....	1
1.3 Applications.....	1
2. Technical Index.....	2
2.1 Electrical Index.....	2
2.2 Enviroment Index.....	2
2.3 Mechanical Specifications.....	2
3. Ports Interface.....	3
3.1 Power Interface Ports1.....	3
3.2 Power Interface Ports2.....	3
3.3 Control Signal Interface Ports(44 Pins DB).....	3
3.3.1 Signal Output Interface Ports(Pend&ALM).....	4
3.3.2 Signal Input Interface Ports(PUL, DIR, ENA).....	4
3.4 Encoder Signal Input Interface Ports(15 Pins DB).....	5
3.5 RS232 Communication Interface Ports.....	6
4. Wiring.....	6
4.1 Typical Wiring Diagram.....	6
5. Parameters.....	6
5.1 Parameter Configure.....	6
5.2 Parameter Description.....	7
6. Alarm Funtion.....	9
6.1 Alarm Configure.....	9
6.2 Processing Method to Alarms.....	9
7. Display and Panel.....	10
7.1 Main Menu Display.....	11
7.2 Sub Menu Display.....	11
7.2.1 Monitor Mode.....	11
7.2.2 Parameter Setting.....	12
7.2.3 Parameter Management.....	12
7.2.4 JOG Mode.....	13

1. Brief Introduction

1.1 Overview

The 3HSS2260A is a hybrid high power stepper servo driver. It fits the 86(NEMA 34) and 110(NEMA 42) three-phase stepper motor. Compared to the traditional open-loop stepper driver, this stepper servo driver can completely avoid the stepper motor lost step problem, the high speed torque decrease is extremely lower than the open-loop stepper driver, greatly enhance the performance and torque of high speed motor. The driver current can be automatic controlled based on the load, it effectively restrain the temperature rise of the motor, extend the motor working life. Build-in position and alarm signal output are convenient for host computer to monitor and control the motor running state. The function of over position error alarm ensure the equipment working safely. It is the ideal replacement and upgrade of traditional open loop driver, and it is also with part functions of AC servo system, price is only half of the AC system.

1.2 Features

- ★ 32-bit DSP and vector closed-loop control technology
- ★ Without losing step, high accuracy in position
- ★ Improve the motor output torque and working speed
- ★ Variable current control technology, restrain motor temperature rise
- ★ Adapt to variety of mechanical load conditions(including low-rigidity pulleys), no need to adjust the gain parameter
- ★ Smooth and reliable moving, low vibration, great improvement in accelerate and decelerate
- ★ The ability of zero speed static without vibration
- ★ Adapt to 3-phase 86(NEMA34) and 110(NEMA 42) hybrid servo motor
- ★ Maximum step-pulse frequency 200KHZ
- ★ Micro step 400-60000 pulse/rev
- ★ Voltage range AC150-240V
- ★ Over current, over voltage and over position protection
- ★ Six digital tube display, easy to set parameters and monitor the motor running state

1.3 Applications

It is suitable for the automation equipment and instrumentation which require large torque, such as: engraving machine, sewing machine, wire-stripping machine, marking machine, cutting machine, laser photo composing machine, plotting instrument, numerical control machine tool, automatic assembly equipment and so on. It is with good performance in the equipment with little noise and high speed.

2. Technical Index

2.1 Electrical Index

Input Voltage	AC150~240V
Current output	Peak 6.0A(current variable based on load)
Logic Current Input	7~20mA
Frequency	0~200KHz
Suitable motor	3-phase NEMA34 and NEMA42 hybrid servo motor
Encoder Resolution	1000
Insulation Resistance	$\geq 500M\Omega$

2.2 Environment Index

Cooling Method	Natural cooling or forced air cooling
Working Environment	Avoid dust, oil fog and corrosive gasses
Working Temperature	0~50°C
Humidity	40~90%RH
Vibration	5.9m/s ² Max
Storage Environment	-20°C~65°C
Weight	Approximate 1500g

2.3 Mechanical Specification

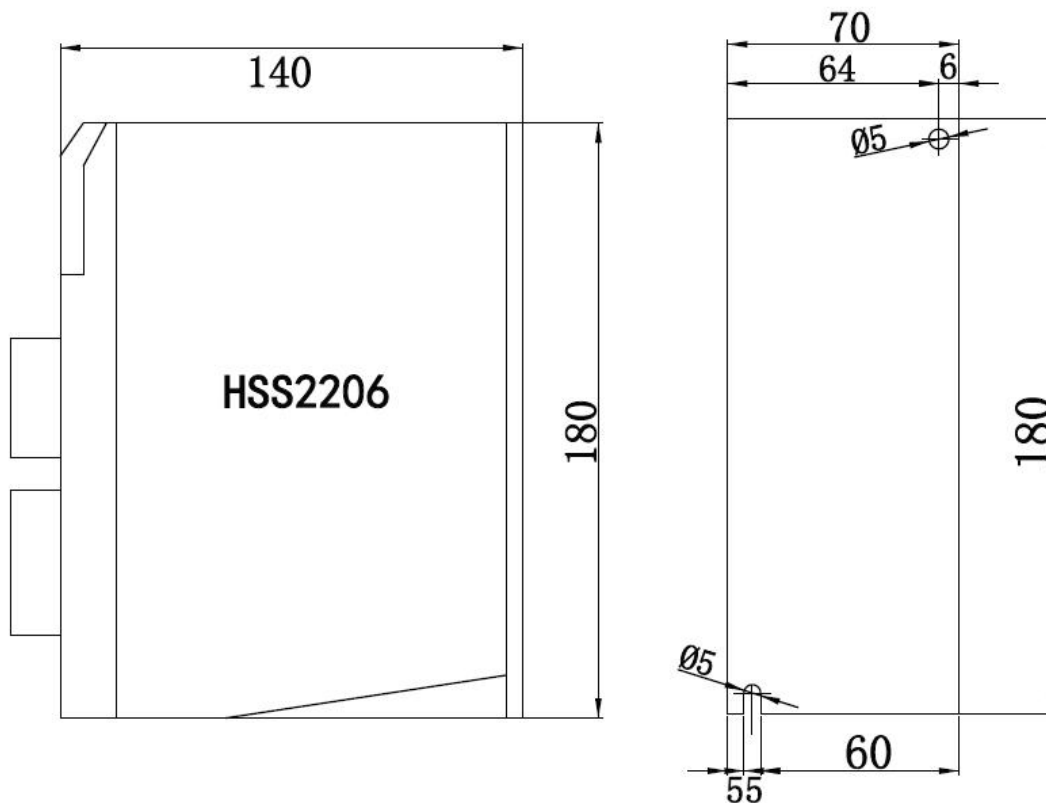

3. Ports Interface

3.1 Power Interface Ports1

Port	Symbol	Definition	Remark
1	L	Motor power Connector to 220AC	
2	N		
3	NC	Not Connected	
4	BR	Braking Resistor	External braking resistor connected between Br and P+
5	P+	DC Busbar Voltage	

3.2 Power Interface Ports2

Port	Symbol	Definition	NEMA34	NEMA42
1	U	Motor Connection Port U	Red	Black
2	V	Motor Connection Port V	Black	Brown
3	W	Motor Connection Port W	Blue	Blue
4	PE	Ground	yellow	yellow
5	L	Controller power Connect to 220VAC	Range AC150-240V	
6	N			

3.3 Control Signal Interface Ports(44 Pins DB)

Port	Symbol	Definition	Remark
3	PUL+	Pulse Signal Input +	5V signal input. If 12V signal input, additional 1K Ω resistor need to be connected. If 24V signal input, Additional 2K Ω resistor need to be connected.
4	PUL-	Pulse Signal Input -	
5	DIR+	Direction Signal Input +	
6	DIR-	Direction Signal Input -	
7	ALM+	Alarm Signal Output +	
8	ALM-	Alarm Signal Output -	
9	PEND+	Position Signal Output +	
10	PEND-	Position Signal Output -	
11	ENA+	Enable Signal Input +	5V signal input. If 12V signal input, additional 1K Ω resistor need to be connected. If 24V signal input, Additional 2K Ω resistor need to be connected.
12	ENA-	Enable Signal Input -	
23	OA+	Encoder A Output	Encoder A,B,Z Signal differential drive(26LS31) output, non-isolated output. If
24	OA-		
25	OB+	Encoder B Output	

26	OB-		the motor only with A,B two channel encoder, then ignore Z channel.
27	OZ+	Encoder Z Output	
28	OZ-		
29	CZ	Encoder Z open collector output	
30	GND	Ground	

3.3.1 Signal Output Interface Ports(Pend&ALM)

Pend and ALM signal output circuit use Darlington optocoupler, it can be connected with the relay or optocoupler. Note the following points:

- ★ Use a power supply to provide the power to the reply or optocoupler, the driver will be burned if the power supply is misconnected.
- ★ Power supply Maximum 25VDC, Maximum current 50mA.
- ★ If using inductive load such as a relay, a diode must be parallel with the inductive load, and if the polarity of the diode is reversed, the driver will be damaged.
- ★ When turned on, there is about 1V or so pressure drop, it can not meet TTL low level requirements, so it can not be connected with TTL current.

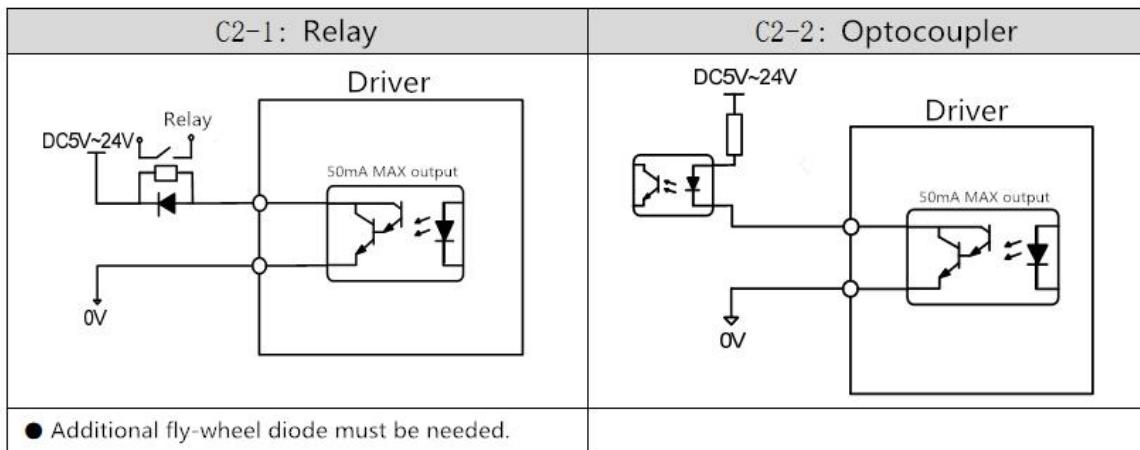

3.3.2 Signal Input Interface Ports(PUL, DIR, ENA)

★ Connections to Differential Signal

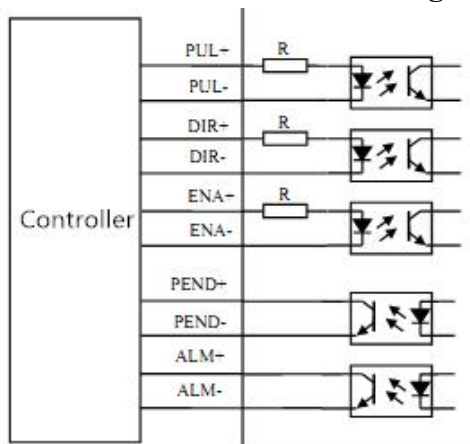

★ Connections to Common Anode

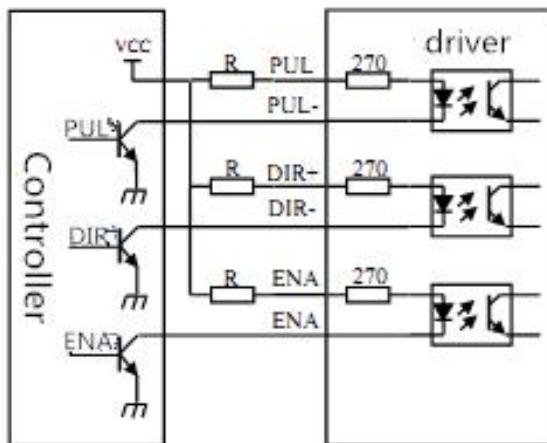

★ Connections to Common Cathode

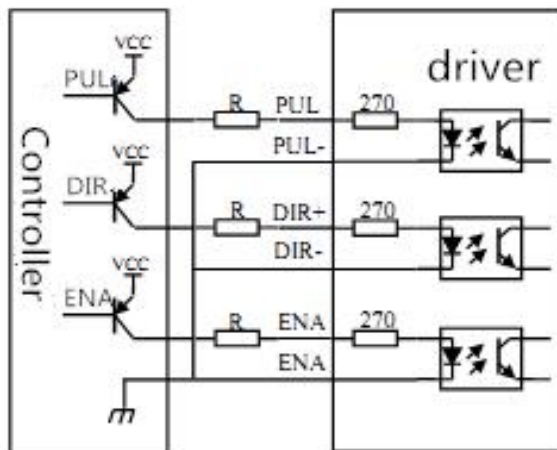

3.4 Encoder Signal Input Interface Ports(15 Pins DB)

Port	Symbol	Definition	Remark
1	EA+	Encoder A+ Input	If the motor only with A,B two channel encoder, then ignore Z channel.
11	EA-	Encoder A- Input	
2	EB+	Encoder B+ Input	
12	EB-	Encoder B- Input	
7	EZ+	Encoder Z+ Input	
8	EZ-	Encoder Z- Input	
13	VCC	+5V	
3	GND	Ground	

3.5 RS232 Communication Interface Ports

Port	Symbol	Definition
1	NC	Not Connected
2	+5V	For External HISU
3	TxD	RS232 Transmission Port
4	GND	Ground
5	RxD	RS232 Receiving Port
6	NC	Not Connected

4. Wiring

4.1 Typical Wiring Diagram

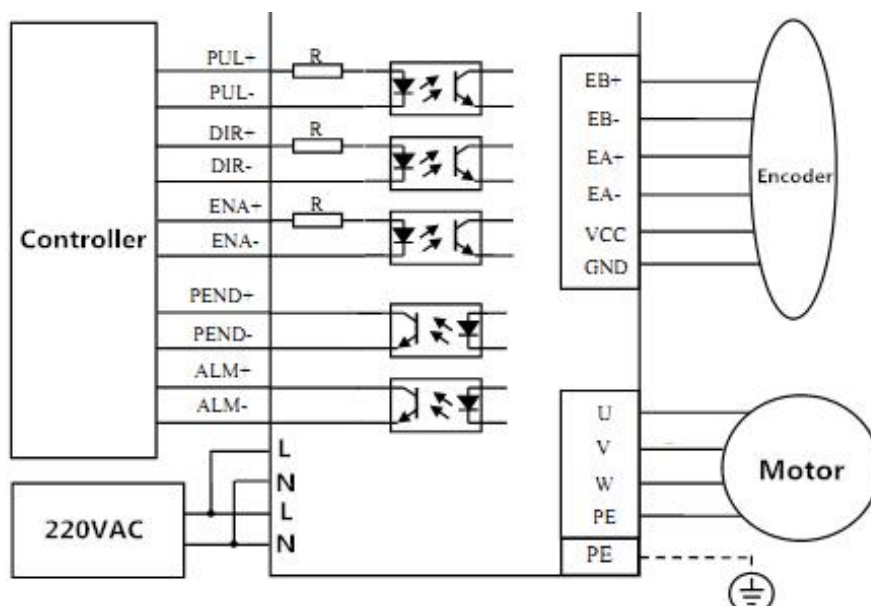

5. Parameters

5.1 Parameter Configure

Code	Definition	Range	Default Value	Remark
PA0	Version Number		501	Prohibited to Modify
PA1	Control Mode Selection	0~2	0	
PA2	Motor Type Selection	0~2	0	
PA3	Power On Display	0~7	0	
PA4	Current Loop Kp	0~1000	200	Prohibited to Modify
PA5	Current Loop Ki	0~1000	300	Prohibited to Modify
PA6	Position Loop Kp	0~1000	300	
PA7	Micro Steps Setting	400~60000	4000	

PA8	Encoder Resolution(1000)		4000	Prohibited to Modify
PA9	Position Error Limit	40~30000	1000	
PA10	Holding Current	10~100	40	
PA11	Closed Loop Current	10~100	100	
PA12	Reservation			
PA13	Reservation			
PA14	Enable Level	0/1	0	
PA15	Alarm Level	0/1	0	
PA16	Pulse Mode Selection	0/1	0	
PA17	Pulse Edge	0/1	0	
PA18	Motor Rotation Direction	0/1	0	
PA19	JOG Speed	1~200	60	
PA20	PEND Mode Section	0/1	0	
PA21	PEND Level	0/1	0	

5.2 Parameter Description

Code	Definition	Description	Range
PA0	Version Number	Prohibited to Modify	501
PA1	Control Mode Selection	<p>★ 0: Closed loop mode: Receiving the Signals both from the signal input ports and the encoder, the motor position is closed loop controlled by the driver. Motor current is automatic changed based on the load.</p> <p>★ 1: Open loop Mode: Receiving the signals only from the signal input ports, the motor is open loop controlled by the driver. Motor current is depending on the holding current(PA10)</p> <p>★ 2: JOG mode: Press ↑ button and hold on, the motor will run at JOG speed. Release ↑ button, the motor will stop and hold on 0 speed. Press ↓ button and hold on, motor will run in reverse. Release ↓ button, the motor will stop and hold on 0 speed.</p>	0~2
PA2	Motor Type Selection	<p>★ 0: 3-phase NEMA34 8N.m</p> <p>★ 1: 3-phase NEMA42 12N.M</p> <p>★ 2: 3-phase NEMA42 20N.M</p>	0~2
PA3	Power On Display	<p>When the driver is powered on, the display shows:</p> <p>★ 0: Position tracking error</p> <p>★ 1: Motor speed</p>	0~7

		<ul style="list-style-type: none"> ★ 2: Given speed ★ 3: Feedback Pulse ★ 4: Given Pulse ★ 5: Given Current ★ 6: Error code ★ 7: Busbar voltage 	
PA4	Current Loop Kp	Prohibited to Modify	
PA5	Current Loop Ki	Prohibited to Modify	
PA6	Position Loop Kp	<ul style="list-style-type: none"> ★ The higher value setting, the higher gain and the greater stiffness, and the smaller position lag under the same frequency command pulse condition. But too large value, may cause oscillation unstable system. The value setting depends on the load. 	0~1000
PA7	Micro Steps Setting	★ Micro Steps Setting	400~60000
PA8	Encoder Resolution(1000)	★ Prohibited to Modify(encoder resolution is 1000 lines, the PA8 value is 4 times of the resolution).	4000
PA9	Position Error Limit	★ At closed loop and JOG mode, if the position error exceed the setting value, the driver will go into position error alarm.	40~30000
PA10	Holding Current	★ Holding current=6A* setting value/100	10~100
PA11	Closed Loop Current	★ Closed loop current=6A* setting value/100	10~100
PA12	Reservation		
PA13	Reservation		
PA14	Enable Level	<ul style="list-style-type: none"> ★ 0: When ENA input optocoupler transistor is OFF (cut off), motor is enable; When ENA input optocoupler transistor is ON (conductive), motor is free. ★ 1: When ENA input optocoupler transistor is ON (conductive), motor is enable; When ENA input optocoupler transistor OFF (cut off), motor is free. 	0~1
PA15	Alarm Level	<ul style="list-style-type: none"> ★ 0: When alarm, output optocoupler transistor is ON (conductive); When normal working, output optocoupler transistor is OFF (cut off) ★ 1: When alarm, output optocoupler transistor is OFF (cut off); When 	0~1

		normal working, output optocoupler transistor is ON (conductive)	
PA16	Pulse Mode Selection	★ 0: Command pulse+symbolic mode ★ 1: CCW/CW mode	0~1
PA17	Pulse Edge	★ 0: Normal ★ 1: Input command pulse reverse polarity	0~1
PA18	Motor Rotation Direction	★ 0: motor clockwise rotation ★ 1: Anticlockwise rotation	0~1
PA19	JOG Speed	★ Set JOG speed	1~200
PA20	PEND Mode Section	★ 0: PEND as position output signal. ★ 1: PNED as brake output signal.	0~1
PA21	PEND Level	★ 0: When positioning or braking OK, output optocoupler transistor is ON (conductive); otherwise output optocoupler transistor is OFF (cut off) ★ 1: When positioning or braking OK, output optocoupler transistor is OFF (cut off); otherwise output optocoupler transistor is ON (conductive)	0~1

6. Alarm Function

6.1 Alarm Configure

ALM Code	Alarm Definition	Description
--	Working OK	
1	Over current	Motor current is too high
2	Over voltage	Main circuit power voltage is too high
3	Position deviation error	The position deviation exceeds the set value.
4	EEPROM fault	EEPROM fault

6.2 Processing Method to Alarms

ALM Code	Alarm Definition	Reason	Processing method
1	Over current	Driver U, V, W short circuit.	Check the wiring.
		Grounding problem	Check ground.
		Motor insulation is damaged	Change a new motor.
		Driver is damaged	Change a new driver.
2	Over Voltage	When the power is turned on, the voltage is too high or too	Check the input power.

		low.	
		The braking resistor wiring is sudden disconnected when the motor is running.	Rewiring.
		The braking resistor or braking transistor is damaged.	Change a new driver.
3	Position deviation error	When control power is turned on, circuit board is damaged.	Change a new driver.
		If motor U, V, W wrong wiring or encoder wrong wiring, the motor will be reverse running or not working,	Rewiring.
		Encoder is damaged	Change a new driver.
		The position deviation value range is too small.	Increase the position deviation value range.
		Position loop Kp is too low.	Increase the position loop Kp value.
		Insufficient torque.	Reduce the load or change a higher torque motor.
		Command pulse frequency is too high.	Reduce the frequency.
4	EEPROM fault	Chip or Circuit board is damaged.	Change a new driver.
		There is interference in the process of reading and writing EEPROM.	Restore the default parameters.

7. Display and Panel

The panel is composed by 6 LED digital tube displays and 5 buttons including ←、↑、↓、S(Shift)、ENT.

‘←’: Exit or Cancel

‘↑’: Increase or Next

‘↓’: Decrease or Previous

‘S’: Left shift digits

‘ENT’: Enter or Confirm

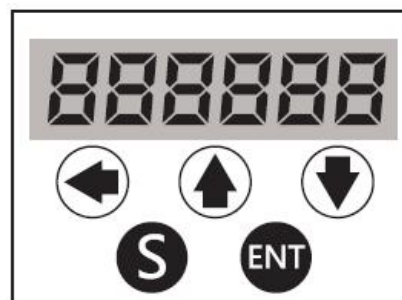

7.1 Main Menu Display

The operation mode is selected from the main menu. There are 4 operation mode: monitor mode, parameter setting, parameter management and JOG mode. Press the button \uparrow and \downarrow to change the mode, press the button ENT to enter the sub menu, press button \leftarrow to back to the main menu.

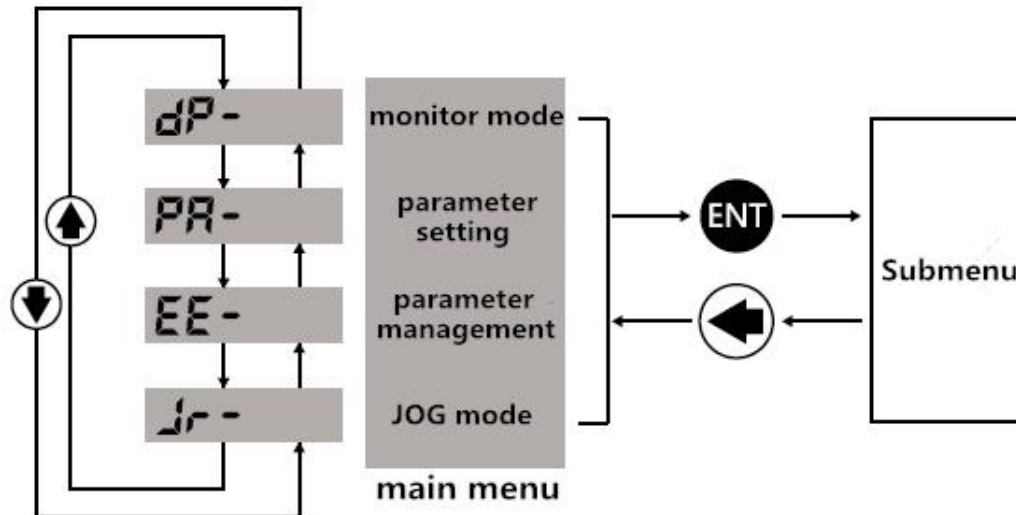

7.2 Sub Menu Display

7.2.1 Monitor Mode

Choose 'dP-' from the main menu, press button ENT to the monitor mode. There are 8 display status, press button \uparrow and \downarrow to choose the status, press button ENT to show the exact value.

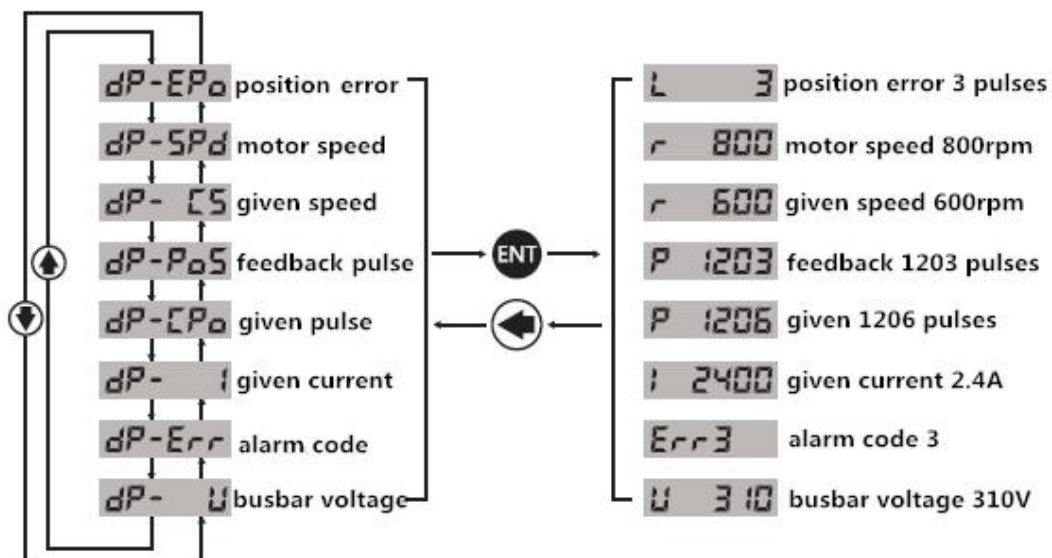

7.2.2 Parameter Setting

Choose 'PA-' from the main menu, press button ENT to the parameter setting mode. There are 21 parameter codes from PA01 to PA21, press button ↑ and ↓ to choose the parameter code, press button ENT to show the parameter value. Press button ↑ and ↓ can modify the values. Button S can left shift the digits, and press button ↑ and ↓ to increase or decrease the shining digit. Press button ENT can confirm the modification. If you do not satisfy the modified value, do not press button ENT instead to press button ← to back to the original value.

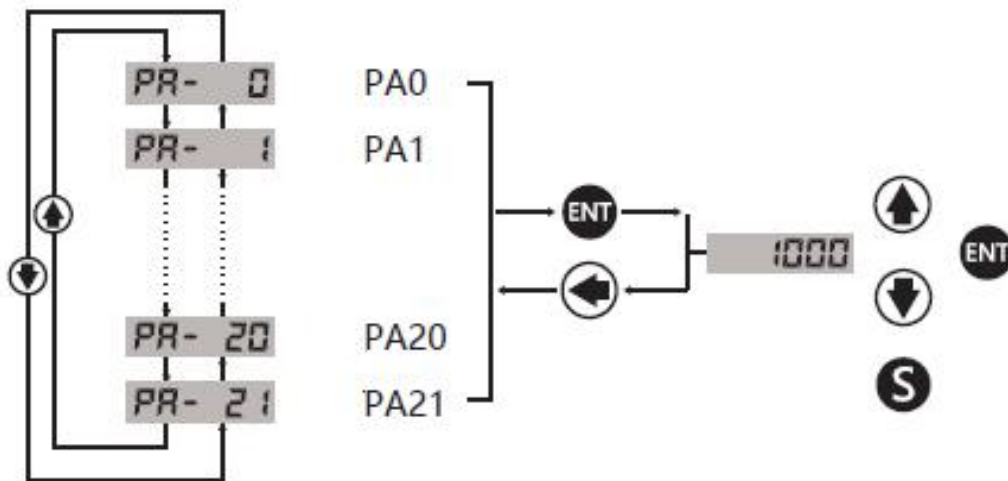

7.2.3 Parameter Management

Parameter management mainly process the operation between parameter configure and EEPROM. Choose 'EE-' from the main menu, press button ENT to the parameter management mode. There are 3 modes: EE-Set, EE-rd and EE-dEF.

EE-Set: 'parameter write into', means write the parameters into EEPROM area. If users only modify the parameters, but do not write into the EEPROM area, the modified parameter will not be stored, it will restore the original value when power on next time. But if the parameter write into the EEPROM area, it will be the modified value when power on next time.

EE-rd: 'parameter read', means read the parameter in EEPROM area to RAM area. This process will be executed once on power. At the beginning, the parameter value of the RAM space is the same as in the EEPROM area. But when user changes the parameters, it will change the RAM space parameter values. if the user is not satisfied with the modified values or the parameter values is disturbed, the parameter read operation can read the parameter in EEPROM area again in to RAM space.

EE-dEF: 'factory reset', means restoring the default value to RAM space, and meanwhile write into EEPROM area. The operation can be used when the users disturb the parameters and can not work properly.

Take EE-Set as an example: Choose the mode EE-Set, press the button ENT and hold 3 seconds, the display show 'Start', that means the parameters are writing into the EEPROM, after 1-2 seconds, if EE-Set operation is successful, the display will

show 'Done', if the operation is failed, the display will show 'Error'. Press button ← can be back to the main menu.

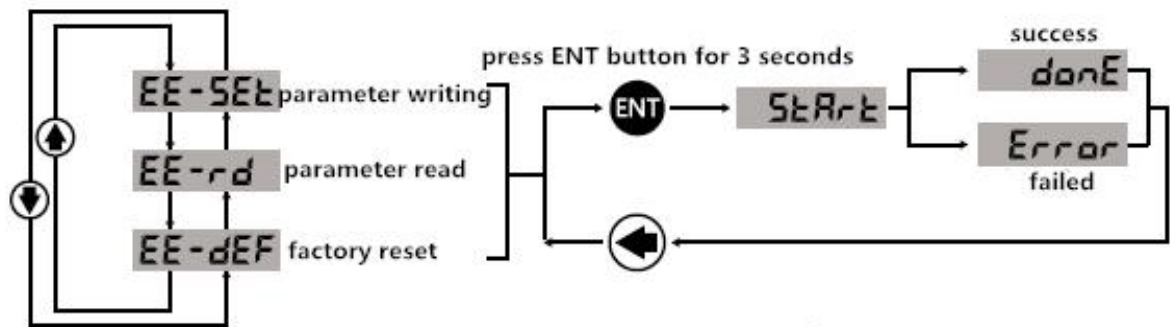

7.2.4 JOG Mode

JOG mode: set PA1=2, let the control mode to be JOG mode. Set the JOG speed by setting PA19, choose the JOG mode at the main menu. Press button ↑ and hold, the motor will run at the JOG speed, Release button ↑, the motor will stop and hold on 0 speed. Press button ↓ and hold on, motor will run in reverse. Release button ↓, the motor will stop and hold on 0 speed.