

## Application

The TAC I/A Series MicroNet™ MNL-5Rxx (MN 50) Controller is an interoperable controller designed in accordance with LONMARK® guidelines. When loaded with a pre-engineered application from the WorkPlace Tech Tool application library, or programmed using WorkPlace Tech Tool, these controllers provide control for packaged rooftops, heat pumps, fan coils, unit ventilators, and similar applications. This controller features MN-Sx digital sensor support, one digital input, one universal input, and three digital outputs. This controller functions in standalone mode or as part of a MicroNet LONWORKS® network using the integral FT 3150® Free Topology communications transceiver. A direct connection to a WPA-LON WorkPlace Communication adapter and a PC with WorkPlace Tech Tool software is necessary to download and modify applications.

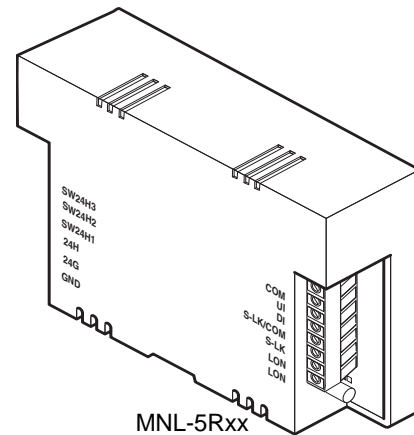

## Model Chart

MNL-5RFx	MN 50 Controller with Fan Coil Profile (8020)	1 Digital Input (DI) 1 Universal Inputs (UI) 3 Digital Outputs (DO)
MNL-5RHx	MN 50 Controller with Heat Pump Profile (8051)	
MNL-5RRx	MN 50 Controller with Rooftop Profile (8030)	
MNL-5RSx	MN 50 Controller with Satellite Profile (8030)	

# Applicable Documentation

F-Number	Description	Audience	Purpose
F-26277	TAC I/A Series MicroNet MN-Sx Series Sensors General Instructions	<ul style="list-style-type: none"> <li>– Application Engineers</li> <li>– Installers</li> <li>– Service Personnel</li> <li>– Start-up Technicians</li> </ul>	Provides step-by-step installation and checkout procedures for TAC I/A Series MicroNet MN-Sx Series Sensors. Also contains instructions for sensor operation.
F-26303	TAC I/A Series MicroNet System Overview	<ul style="list-style-type: none"> <li>– Application engineers</li> <li>– Installers</li> <li>– Start-up technicians</li> <li>– Service personnel</li> </ul>	Provides an overview of the TAC I/A Series MicroNet System. It includes brief descriptions of the hardware and software components, and how they may be combined to create MicroNet networks and stand-alone systems.
F-27254	WorkPlace Tech Tool 4.0 Engineering Guide	<ul style="list-style-type: none"> <li>– Application Engineers</li> <li>– Installers</li> <li>– Service Personnel</li> <li>– Start-up Technicians</li> </ul>	Provides engineering and technical information for applying and using all aspects of WorkPlace Tech Tool.
F-26507	TAC I/A Series MicroNet Systems Engineering Guide	<ul style="list-style-type: none"> <li>– Application Engineers</li> <li>– Installers</li> <li>– Service Personnel</li> <li>– Start-up Technicians</li> </ul>	Provides engineering and technical information to assist in designing a complete MicroNet controller system using different architectures, components, and software.
F-27255	WorkPlace Tech Tool 4.0 User's Guide	<ul style="list-style-type: none"> <li>– Application Engineers</li> <li>– Installers</li> <li>– Service Personnel</li> <li>– Start-up Technicians</li> </ul>	Provides step-by-step instructions for using WorkPlace Tech Tool.
F-26363	EN-206 Guidelines for Powering Multiple Full-Wave and Half-Wave Rectifier Devices from a Common Transformer	<ul style="list-style-type: none"> <li>– Application Engineers</li> <li>– Installers</li> <li>– Service Personnel</li> </ul>	Offers guidelines for avoiding equipment damage associated with improperly wiring devices of varying rectifier types. Contains instructions for identifying device rectifier type, guidelines for correctly powering devices of varying rectifier types, and examples illustrating proper power wiring techniques.

## Installation

### Inspection

Inspect carton for damage. If damaged, notify carrier immediately. Inspect controllers for damage upon receipt.

### Requirements

(These items not provided)

- Installer must be a qualified technician
- Job wiring diagrams
- Tools:
  - Digital Volt-ohm meter (DVM)
  - Drill and bits for mounting screw
  - Static protection wrist strap
- MNA-FLO-1 enclosure for connecting to conduit (optional)
- Class 2 power transformer supplying a nominal 24 VAC (20.4 to 30 VAC) with a minimum rating of 12 VA, 50/60 Hz per controller, plus Digital Output (DO). Each DO can be up to an additional 24VA maximum. In European Community, transformer must conform to EN 60742
- Terminators:
  - One LON-TERM1 terminator required for each free topology segment
  - Two LON-TERM2 terminators required for each bus topology segment
- Two #10 sheet metal screws

## Precautions



### General

---

**Warning:** Electrical shock hazard! Disconnect power before installing or removing the cover.

---

- Follow Static precautions when installing this equipment.
- Use copper conductors that are suitable for 167°F (75°C).
- Make all connections according to electrical wiring diagram, national and local electrical codes.

### Static Precautions

Static charges damage electronic components. The microprocessor and associated circuitry are extremely sensitive to static discharge. Use the following precautions when installing, servicing, or operating the system.

- Work in a static-free area.
- Discharge static electricity by touching a known, securely grounded object.
- Use a wrist strap connected to earth ground when handling the controller's printed circuit board.

### Federal Communications Commission (FCC)

This equipment has been tested and found to comply with the limits for a Class B digital device, pursuant to Part 15 of the FCC Rules. These limits are designed to provide reasonable protection against harmful interference in residential installations. This equipment generates, uses, and can radiate radio frequency energy and may cause harmful interference if not installed and used in accordance with the instructions. Even when instructions are followed, there is no guarantee that interference will not occur in a particular installation. If this equipment causes harmful interference to radio or television reception—which can be determined by turning the equipment off and on—the user is encouraged to try to correct the interference by one or more of the following measures:

- Reorient or relocate the receiving antenna.
- Increase the separation between the equipment and receiver.
- Connect the equipment to an outlet on a circuit different from that to which the receiver is connected.
- Consult the dealer or an experienced radio/television technician for help.

### Canadian Department of Communications (DOC)

This class B digital apparatus meets all requirements of the Canadian Interference-Causing Equipment Regulations.

### European Community Directives

This equipment meets all requirements of European Community Directives for Low Voltage (72/23/EEC), General Safety (92/59/EEC), and Electromagnetic Compatibility (89/336/EEC).

## Location

The MN 50 controllers are suitable for indoor use only.

---

**Caution:**

- Avoid locations where excessive moisture, corrosive fumes, vibration, or explosive vapors are present.
  - Avoid electrical noise interference. Do not install near large contactors, electrical machinery, or welding equipment.
  - Locate where ambient temperatures do not exceed 140°F (60°C) or fall below -40°F (-40°C) and relative humidity does not exceed 95% or fall below 5%, non-condensing.
-

## Mounting

MN 50 controllers can be mounted in any direction and on any plane. Mounting dimensions are shown in Figure-1

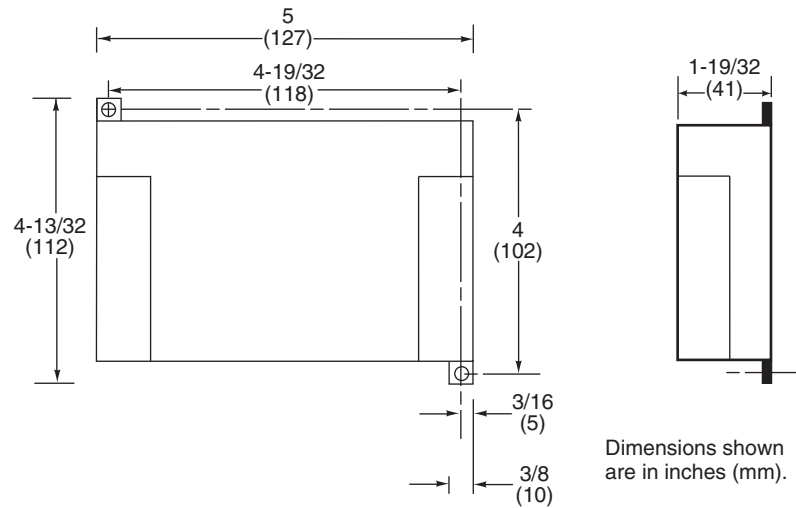

Figure-1 Mounting Dimensions.

## Wiring

The following electrical connections can be made to TAC I/A Series MicroNet MN 50 controllers:

- Sensor Link (S-Link) connection to a TAC I/A Series MicroNet Sensor (MN-Sx)
- MicroNet LONWORKS network (LON<sup>®</sup>) connection
- LONWORKS network connection from controller to a TAC I/A Series MicroNet Sensor
- I/O connections including:
  - One Universal Input (UI)
  - One Digital Input (DI)
  - Three Digital Outputs (DO)
- Power connection to a 24 VAC nominal Class 2 (EN 60742) power source and earth ground.

See Figure-2 for wiring terminal information.

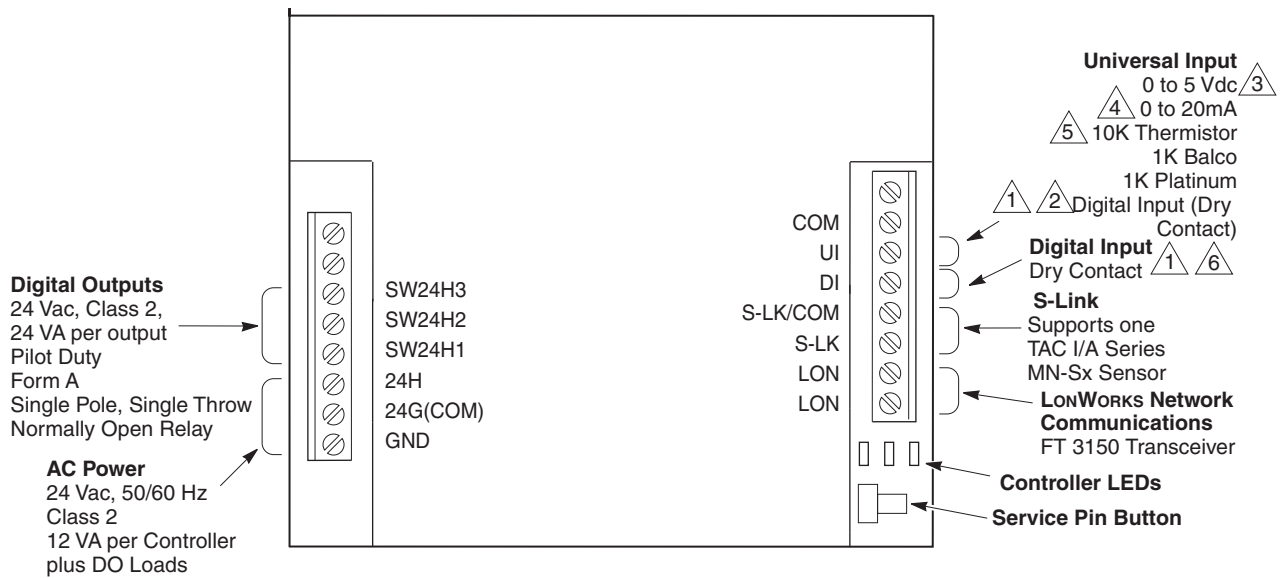

- 1 To detect a closed switch, maximum resistance must be less than 300 ohms.
- 2 To detect an open switch, minimum resistance must be greater than 1.5K ohms.
- 3 Input signals of 1 to 11 Vdc must be converted to 0.45 to 5 Vdc with a voltage divider, AD-8961-220.
- 4 Applications which use 0 to 20 mA analog inputs require a 250 ohms shunt resistor kit, AD-8969-202. Install resistor across universal input and common.
- 5 Applications which use a 10K Thermistor Sensor (non-850 series) universal input require an 11K ohms shunt resistor kit, AD-8969-206. Install resistor across universal input and common.
- 6 To detect an open switch, minimum resistance must be greater than 100K ohms.

Figure-2 MN 50 Terminal Connections.

## Communications Wiring

---

### **Caution:**

- Communication wire pairs must be dedicated to MN-Sx (S-Link) and MicroNet LONWORKS network (LON) communications. They cannot be part of an active, bundled telephone trunk.
  - Shielded cable is not required for S-Link or LON wiring.
  - If the cable is installed in areas of high RFI/EMI, the cable must be in conduit.
  - If shielded wire is used, the shield must be connected to earth ground at one end only by a 470K ohm 1/4 watt resistor. Shield must be continuous from one end of the trunk to the other.
- 

Communications wiring includes a connection between the controller and a TAC I/A Series MicroNet Sensor via the S-Link and a connection between the controller and the MicroNet LONWORKS Network (LON). An optional LONWORKS Network connection between the controller and one TAC I/A Series MicroNet Sensor is also possible. Figure-2 shows S-Link and LON wiring terminations.

### **Sensor Link (S-Link) Wiring**

S-Link wiring powers and enables the MN-Sx sensor. The S-Link needs at least 24 gage (0.51mm), twisted pair, voice grade telephone wire. The capacitance between conductors cannot be more than 32 pF per foot (0.3m). If shielded cable is used, the capacitance between any one conductor and the others, connected to the shield, cannot be more than 60 pF per foot (0.3m). Maximum wire length is 200 ft. (61m).

---

#### *Note:*

- Controller supports one TAC I/A Series MicroNet Sensor (MN-Sx).
  - S-Link wiring is polarity insensitive.
  - If conduit is used between a TAC I/A Series Sensor and a controller, the MicroNet LONWORKS network and S-Link wiring can be in the same conduit, however, they must be separate cables.
  - S-Link wiring can be in the same conduit with UI and DI Wiring.
- 

### **MicroNet LONWORKS Network (LON) Wiring**

An approved category 4 or 5, twisted-pair cable may be used for both connecting to the MicroNet LONWORKS network and the optional LONWORKS network connection between the controller and MN-Sx sensor. LONWORKS network wiring is polarity insensitive.

---

**Caution:** Do not mix with UI, DI, DO, or power types of wiring. If conduit is used between a TAC I/A Series Sensor and a controller, LONWORKS network wiring and S-Link wiring can be in the same conduit, however, they must be separate cables.

---

MN 50 controllers use LONWORKS Free Topology Transceiver (FT 3150) and support polarity insensitive bus (daisy-chain) and free (all combinations of star, tee, and loop) wiring topologies. A maximum of 62 nodes can be connected per segment.

See *TAC I/A Series MicroNet System Engineering Guide, F-26507* to design a MicroNet LONWORKS TP/FT-10 network, including recommended topologies and approved cable types.

#### **Note:**

- Use of the LON terminals to connect to the MN-Sx sensor permits use of the sensor's built-in LON Jack.
- To preserve the integrity of the network, the LON wiring connecting a TAC I/A Series MicroNet controller to an MN-Sx sensor must be run to the sensor and back, in daisy-chain fashion. A wire "spur" must not be used to connect the sensor to the controller.
- While the MN-Sx sensor is not counted as a "node" in the LonWorks network (LON), all LON wiring to the sensor must be counted when determining the length of the FTT wiring segment.

## I/O Wiring

I/O connections include universal input, digital input, and digital outputs. See Figure-2 for proper wire terminal information.

---

**Caution:** If shielded wire is used, connect only one end of the shield to earth ground at the controller.

---

## Universal Input (UI) and Digital Input (DI)

---

**Caution:**

- Input and output devices cannot share common wiring. Each connected device requires a separate signal and return conductor.
  - Power wiring cannot share conduit with UI, S-Link, LON, or DI wiring.
- 

**Note:**

- If maximum closed switch voltage is not more than 1.0 V *and* minimum open switch voltage is at least 4.5 V, then solid state switches may be used for a UI or a DI.
  - UI, DI, and S-Link wiring can share a single conduit.
- 

UI, DI, wiring needs at least 24 gage (0.51 mm), twisted pair, voice grade telephone wire. The capacitance between conductors cannot be more than 32 pF per foot (0.3m). If shielded cable is used, the capacitance between any one conductor and the others, connected to the shield, cannot be more than 60 pF per foot (0.3m).

**Table-1 UI and DI Wiring Specifications.**

Connection	Gage AWG (mm)	Maximum Distance ft. (m)
UI and DI	18 (1.02)	300 (91)
	20 (.81)	200 (61)
	22 (.65)	125 (38)
	24 (.51)	75 (23)

## Digital Outputs

---

**Caution:**

- DO wiring cannot be intermixed with DI, UI, S-Link, or LON wiring.
  - DO terminals accept one 16 gage (1.29mm) wire or two 18 gage (1.02mm) wires. The selected wire gage must be consistent with the load current rating.
  - MN 50 controllers are Class 2 only devices where:
    - Each relay output (SW24H1, SW24H2, and SW24H3) can support up to 24 VAC at 24 VA pilot duty.
- 

**Note:**

- Digital Output wiring can be intermixed with class 2 power wiring.
  - The minimum permissible load for Digital Outputs is 10mA at 5 Vdc.
-

## Relay Outputs

Each Relay output is an isolated Form A (SPST) relay that switches the controller's 24H AC input voltage to the output load.

**Table-2 Relay Output Load Specifications.**

Specification	Value
Maximum Relay Contact Switched Output Voltage	voltage at 24H terminal <sup>a</sup>
Maximum Output Load @ 24 VAC, Pilot Duty	24 VA
Minimum Controllable Load	10.0 mA
Maximum Off-state Leakage Current	3.5 mA
Minimum Cycles at Rated Load @ 0.4 Power Factor	300,000 cycles

<sup>a</sup>Switched output voltage is equivalent to value of input voltage.

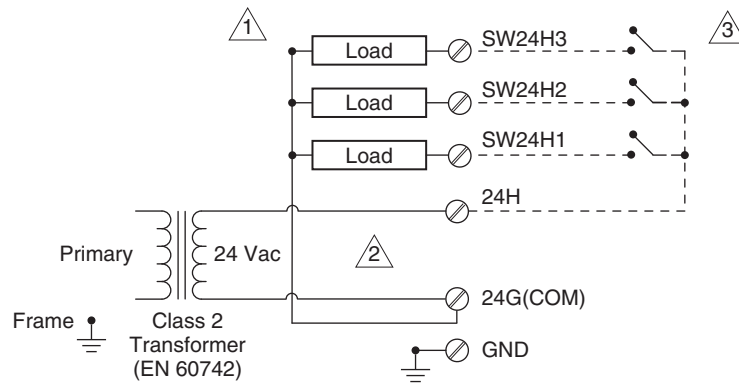

- 1 See application documentation for output designation and wiring specifics.
- 2 Polarity must be maintained (24H connected to 24H and 24G connected to 24G).
- 3 Dashed lines represent internal controller circuitry.

**Figure-3 Relay Output Field Wiring**



## Power Supply Wiring

### Caution:

- This product contains a non-isolated half-wave rectifier power supply and must not be powered by transformers used to power other devices containing non-isolated full-wave rectifier power supplies. Refer to *EN-206, Guidelines for Powering Multiple Full-Wave and Half-Wave Rectifier Devices from a Common Transformer*, F-26363, for detailed information.
- Power wiring cannot be intermixed with LON, S-Link, UI, or DI wiring.
- Use a Class 2 power transformer (EN 60742) supplying a nominal 24 VAC (20.4 to 30 Vac) with a minimum rating of 12 VA at 50/60 Hz plus digital output loads (72 VA total at 24 VA each). The supply to the transformer must have a breaker or disconnect.
- The Class 2 power transformer may be used to power multiple Class 2 powered devices provided that the transformer is properly sized to power all equipment simultaneously and all devices contain the same type of rectifier power supplies or internal isolation.
- The transformer frame must be grounded.
- When powering multiple Class 2 devices from the same Class 2 power transformer, polarity must be observed (24H connected to 24H and 24G connected to 24G).

### Note:

- Power terminals accept one 16 gage (1.29mm) wire or two 18 gage (1.02mm) wires.
- Power wiring can be intermixed with DO wiring.
- Twisted or untwisted cable can be used for power wiring.
- To preserve the integrity of the network, the LON wiring connecting a TAC I/A Series MicroNet controller to an MN-Sx sensor must be run to the sensor and back, in daisy-chain fashion. A wire “spur” must not be used to connect the sensor to the controller.

Figure-4 and Figure-5 are acceptable wiring configurations.

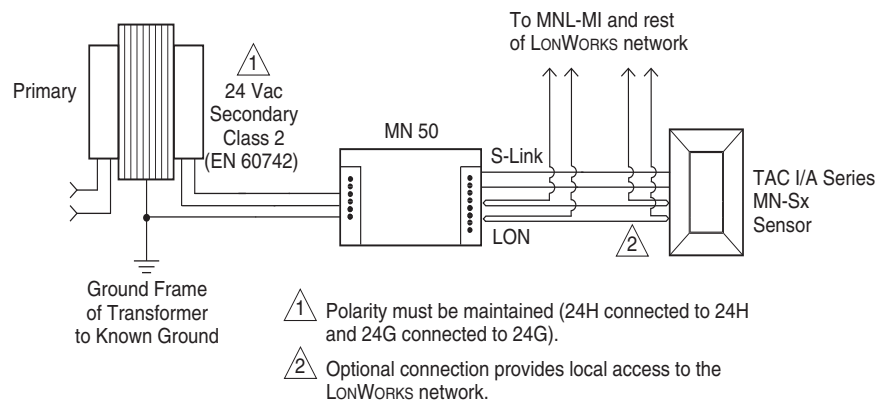

Observe Free or Daisy chain topology when making connections to rest of network.

Figure-4 Single Controller Powered from a Separate Class 2 (EN 60742) Power Source.

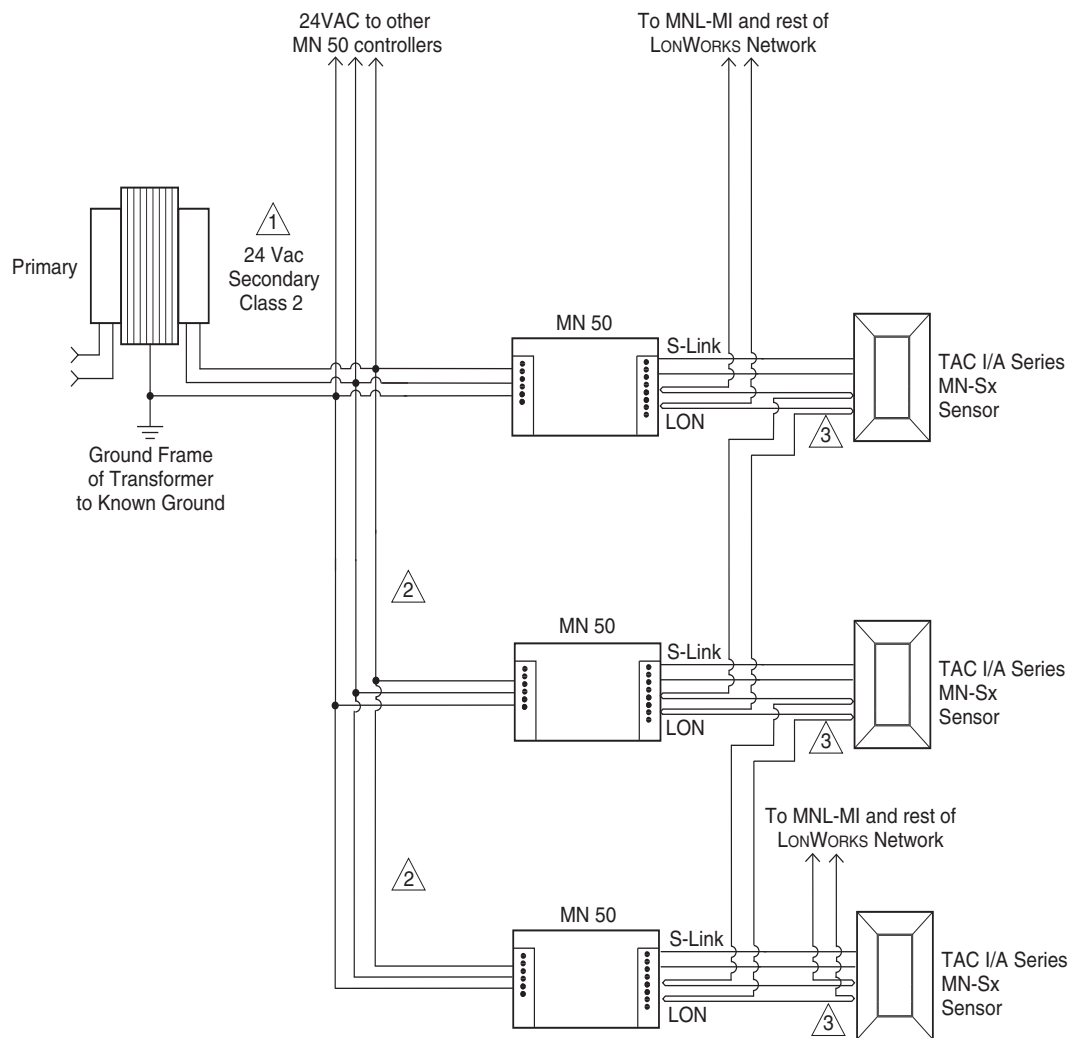

① Polarity must be maintained (24H connected to 24H and 24G connected to 24G).

② Class 2 Wiring (EN 60742).

③ Optional connection provides local access to the LONWORKS network.

Observe Free or Daisy chain topology when making connections to rest of network

Figure-5 Multiple Controllers Powered from a Single Class 2 (EN 60742) Power Source and Sharing Communications in a Free Topology Segment.

# Checkout

## Mechanical Hardware Checkout

1. Verify wiring between TAC I/A Series MicroNet Sensor and controller is installed according to job wiring diagram and national and local wiring codes.

---

*Note:* Wiring of the S-Link and MicroNet LONWORKS network between the sensor and the controller is not polarity sensitive.

---

2. If controller is part of a MicroNet LONWORKS network, verify the TP/FT-10 LONWORKS network wiring between controller and other devices is installed according to job wiring diagram and national and local electrical codes.
3. Verify 24 VAC power is provided from a Class 2 power transformer (EN 60742) and wiring is installed according to job wiring diagrams and national and local electrical codes.
4. If multiple devices are powered from the same transformer, verify wiring polarity has been maintained between all connected devices (24H connected to 24H and 24G connected to 24G).
5. If multiple devices are powered from a common transformer, verify all issues associated with powering multiple devices from a common transformer have been addressed.

---

*Note:* For more information, refer to *EN-206, Guidelines for Powering Multiple Full-Wave and Half-Wave Rectifier Devices from a Common Transformer*, F-26363.

---

6. Verify digital outputs are wired according to job wiring diagram and national and local electrical codes.
7. Make certain current requirements of controlled devices do not exceed rating of controller's digital outputs.

## Communications Hardware Checkout

1. Verify controller is in a manually controlled, safe state.
2. Place controller power breaker in the ON position. See job wiring diagrams.
3. Observe green Data Transmission LED (Figure-6) and do the following:
  - a. If green Data Transmission LED is steady on or blinking, go to step 4.
  - b. If green Data Transmission LED is off, check power.
4. Observe red Service LED (Figure-6) and do one of the following:
  - a. If the red Service LED is off or flashing, proceed with downloading an application using WorkPlace Tech Tool and configuring the controller with a third party network management tool. Refer to *WorkPlace Tech Tool 4.0 Engineering Guide*, F-27254, for details on downloading applications.
  - b. If red Service LED is steady on, turn power to controller OFF, wait five seconds, and turn power ON. If red Service LED is still steady on, turn power OFF and replace controller.
5. If connected to a MicroNet LONWORKS network (LON), verify Reception and Transmission LEDs (Figure-6) indicate normal operation. See Table-3.

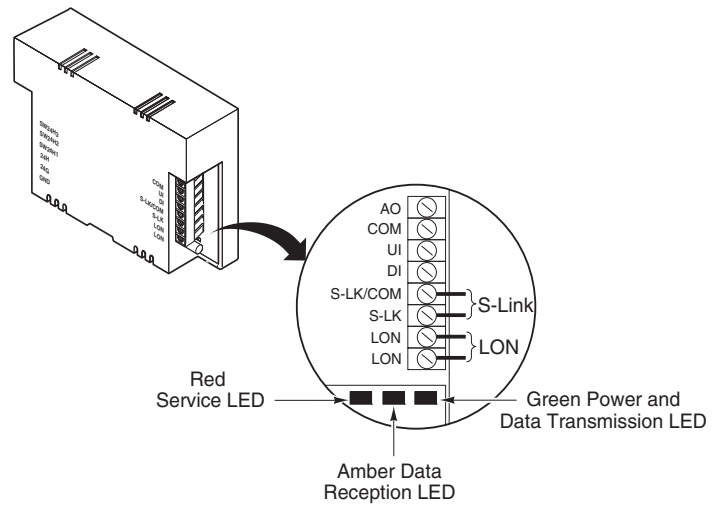

Figure-6 Location of Controller LEDs

**Table-3 LED Indication.**

Indicator	Context	Status	Corrective Action
Data Reception LED – amber	Anytime	Blinks when the controller receives data from the LONWORKS Network.	None required.
		On indicates a possible network connection problem, or a large amount of network traffic is present.	Remove the LONWORKS Network connections from the controller and determine if the LED goes off. If the LED does not go off, replace the controller. If the LED does go off, check the network topology (connections to each node, routers, terminators, etc.) and the amount of traffic on the network.
		Off indicates that data reception is not taking place.	
Data Transmission LED – Green	Anytime	Blinks when the controller transmits data to the LONWORKS Network.	None Required
		On indicates that the controller is not transmitting data. On also indicates that power is being applied to the controller.	
		Off indicates no power to controller.	Check power
Service LED – Red	Power-up	The LED blinks once to indicate successful power-up.	None Required
	Wink mode	Blinks (3 seconds on, 1 second off) three times to indicate physical location of the controller. If a sensor (MN-Sx) is connected, its red occupancy LED will flash (1/sec) during the wink period.	
	Anytime	On indicates that the neuron application is not running. Neuron applications are not field replaceable.	Replace the controller.
	Anytime	Blinks (1/sec) to indicate that the neuron application is loaded, but the neuron's communication parameters are not loaded, are being reloaded, or have been corrupted. Neuron is considered unconfigured. Communication parameters cannot be configured by field personnel.	Use a third party network management tool to commission the controller, or use the change state tool in WorkPlace Tech Tool (version 4.0 or greater) to set the Neuron <sup>®</sup> to the configured/on-line state. While the controller is unconfigured, WorkPlace Tech (WP Tech) can be used to download an application, but at the completion of the download, WP Tech versions 4.0 and higher will restore the Neuron to the unconfigured state.
	Anytime	Off may indicate that the neuron application is loaded but the device is off-line. In this state, a pre-loaded HVAC application will not run.	Use a third party network management tool to commission the controller, or use the change state tool in WorkPlace Tech Tool (version 4.0 or greater) to set the Neuron to the configured/on-line state. While the controller is off-line, WP Tech can be used to download an application, but at the completion of the download, WP Tech versions 4.0 and higher will restore the Neuron to the off-line state.
	Anytime	Off usually indicates a normal state. In this state, the controller operates normally, and you can download and/or run HVAC applications.	If the controller is able to accept and/or run a downloaded HVAC application, no action is required.

## Controller Selection

Identical pairs of factory barcode labels are attached to each controller. The labels can be used to select controllers for application downloading purposes. Each pair of labels contains a unique Neuron ID. One of the labels remains on the controller permanently; the other label can be placed on a job site plan.

The Neuron ID may be entered into the WorkPlace Tech Tool. The WorkPlace Tech Tool (must be version 4.0 or greater) can then download an application to the selected controller. See *WorkPlace Tech Tool 4.0 Users Guide*, F-27255, for additional information.

---

**Caution:** Do not hold service pin button when selecting a controller. Holding the service pin button for 6 seconds or longer will completely unconfigure controller. See *WorkPlace Tech Tool 4.0 Engineering Guide*, F-27254, for additional information.

---

The service pin button is also used to select controllers. When this button is pressed, the controller sends a broadcast message containing its Neuron ID to the online or connected WorkPlace Tech Tool. After the message is received, the controller can be selected for application downloading. See *WorkPlace Tech Tool 4.0 Users Guide*, F-27255, for additional information.

## Service

Components within MN 50 controllers cannot be field repaired. If there is a problem with a controller, follow the steps below before contacting your local Schneider Electric office.

1. Make sure controllers are connected and communicating to desired devices.
2. Check all sensors and controlled devices are properly connected and responding correctly.
3. If controller is operating, make sure the correct profile and application is loaded by checking the LONMARK Program ID and the nvoDeviceInfo using WorkPlace Tech Tool. For more information, see *WorkPlace Tech Tool 4.0 Engineering Guide*, F-27254.
4. Record precise hardware setup indicating the following:
  - Version numbers of applications software.
  - Controller firmware version number.
  - Information regarding the WorkPlace Tech Tool.
  - A complete description of difficulties encountered.

Distributed, manufactured, and sold by Schneider Electric. I/A SERIES trademarks are owned by Invensys Systems, Inc. and are used on this product under master license from Invensys. Invensys does not manufacture this product or provide any product warranty or support. For service, support, and warranty information, contact Schneider Electric at 1-888-444-1311.

On October 1st, 2009, TAC became the Buildings Business of its parent company Schneider Electric. This document reflects the visual identity of Schneider Electric, however there remains references to TAC as a corporate brand in the body copy. As each document is updated, the body copy will be changed to reflect appropriate corporate brand changes.

All brand names, trademarks and registered trademarks are the property of their respective owners. Information contained within this document is subject to change without notice.

**Schneider Electric** 1354 Clifford Avenue, P.O. Box 2940, Loves Park, IL 61132-2940, USA 1-888-444-1311 [www.schneider-electric.com/buildings](http://www.schneider-electric.com/buildings)

F-26617-4

February 2010 tl

© 2010 Schneider Electric. All rights reserved.

