



## OPERATING INSTRUCTIONS

### 70070/70070-M MULTI-SIZE "RATCHET STYLE" TUBE BENDER

#### SAFETY REQUIREMENTS

- Use only soft copper tubing with this bender.
- Always use personal safety equipment (i.e. safety glasses, gloves, etc.)
- Only personnel knowledgeable in the use of tube benders should use this tool.
- Keep bender dry and lubricate ratchet mechanism.

FORMING RADIUS BLOCK		BENDING RADIUS	
3/8" O.D.	(10mm)	1 3/16"	(30mm)
1/2" O.D.	(12mm)	1 3/8"	(35mm)
5/8" O.D.	(16mm)	1 5/8"	(41mm)
3/4" O.D.	(18mm)	2 13/16"	(72mm)
7/8" O.D.	(22mm)	3 3/8"	(86mm)

Diameter Dimensions  
on support blocks

Diameter Dimension  
on radius blocks

#### SETUP AND OPERATION INSTRUCTIONS (FIGURE 1)

NOTE: Tube sizes are outside diameters!

- 1) Choose the cross bar (6) that corresponds to the tubing size that you are going to bend. Install the cross bar in the mainframe (4) slot and tighten wing nut.
- 2) Select the proper size radius block (2) and assemble to the tooth ratchet (3). Press the radius block onto the square end of the tooth ratchet.
- 3) Set support blocks so that the proper diameter dimensions face the tubing. Make sure both blocks have the same diameter showing. Place tube between support blocks and radius block. Start to squeeze ratchet handle (5). The tube will advance into the radius block. Continue operating the ratchet handle until tube is bent to desired angle. To ensure an accurate 90 degree angle, use a "square".
- 4) To remove tube, pull back radius block by pushing ratchet handle away from the mainframe and HOLD in place. Push tubing and radius block towards the ratchet handle. Pull tube out of radius block and check the angle of the tube bend using a "square" or protractor.
- 5) Radius block is removed from the ratchet bar by "wiggling" and pulling block away from the

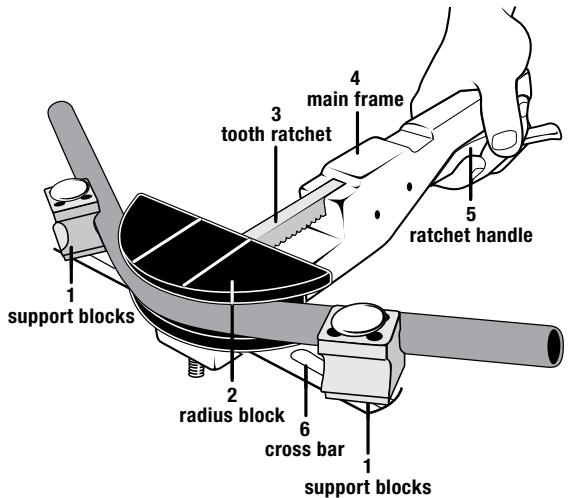

FIGURE 1

toothed ratchet.

## MAKING 90° OFFSET BENDS (FIGURE 2)

- 1) Mark the required length from the end of the tubing.
- 2) Place the tube in the radius block (2) with the measured mark aligned with a raised guide line on the face of the radius block. If the measured end of the tube is on the right side of the bender, use the raised left side guide line. If the measured end of the tube is on the left side of the bender, use the raised right side guide line.

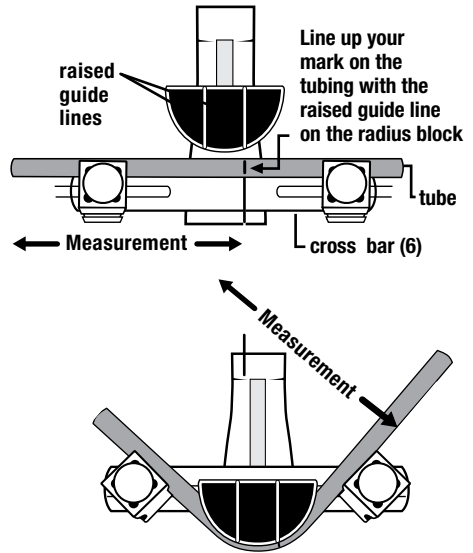

FIGURE 2

## SETUP INSTRUCTIONS FOR REVERSE DIRECTION BENDING ADAPTER (70070-RD)

BENDS: 1/4", 5/16", 3/8", 1/2", 5/8", 3/4", 7/8" O.D. TUBING

### (FIGURE 3)

- 1) Attach adapter (3-1) to bar on bender. Tighten wing nut.
- 2) Install adapter (3-2) on bender body and tighten wing nut.
- 3) Install desired crossbar and radius block (3-3) in the usual way.

