

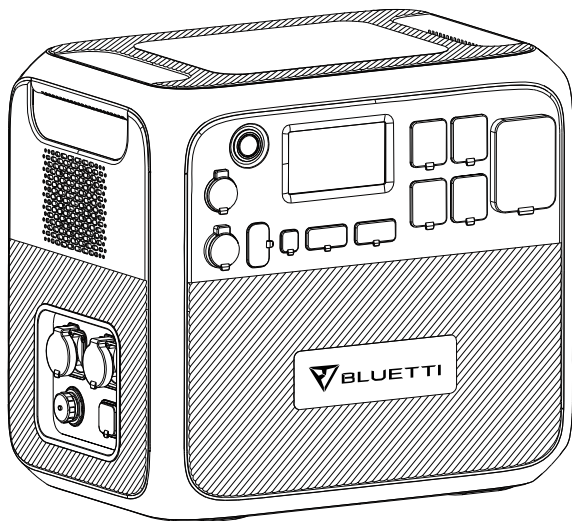

AC200MAX Portable Power Station

Please read and fully understand this manual before use and keep it handy for future reference.



User Manual

Please read and fully understand this manual before use and keep it handy for future reference.

1. BRIEF INTRODUCTION

For I/O capability, the AC200MAX features higher continuous output power at 2,200W from its pure sine wave inverter, 100W PD3.0 USB-C port, upgraded MPPT controller which now handles up to 900W solar input, and built-in 30A NEMA TT-30 outlet designed for RV crowds especially.

Most significantly, considering customers' feedback, comments, and product upgrade need, the BLUETTI AC200MAX now supports Bluetooth connection and the new BLUETTI Smartphone App (iOS & Android) remote control.

Furthermore, the AC200MAX also supports up to 2 expandable battery packs, using either the BLUETTI B230 or B300. With 2 BLUETTI B300, the capacity of AC200MAX then will expand to a massive 8192Wh to run your every essential needs at home or on the go for hours, days, or even more than a week!

2. ABBREVIATION

- BMS: Battery Management System
- MPPT: Maximum Power Point Tracking
- SOC: State of Charge
- AC: Alternating Current
- DC: Direct Current
- PV: Solar Panel(s) Charging (Photovoltaic)
- Grid: Home Power Supplied by Utility
- DOD: Depth of Discharge
- ECO Mode: A power-saving setting for the AC200MAX. When it is on, the AC power will automatically turn off over 4 hours low load ($\leq 50W$) or no load to save power drain.

3. SAFETY INSTRUCTION

- DO keep the AC200MAX away from the fire and heat.
- DO operate the AC200MAX in a dry and well-ventilated place. If it gets moisturized or damp, please dry it thoroughly before use.
- DO NOT obstruct fan openings to ensure proper ventilation in use. Otherwise, permanent damage to the AC200MAX may occur.
- DO NOT move the unit while operating as vibrations and sudden impacts may lead to poor connections to the hardware inside.

- Please use the original charger and cables only designed for the AC200MAX. The company shall not be liable for damage caused by third-party equipment, which also may invalidate your warranty.
- Please carefully read the operating instructions of the electrical products to be connected. Failure to operate the electrical products properly may result in accidents or injuries.
- Please use the AC200MAX power station carefully and keep children away from it.
- WARNING: In case of fire, ONLY dry powder fire extinguisher works.
- WARNING: DO NOT insert foreign objects into any ports of the AC200MAX (AC, DC, or ventilation holes). The power station generates the same potentially lethal AC power as a household wall outlet.
- WARNING: It is hazardous for anyone other than the authorized person to carry out any service or repair operation involving replacing the internal battery or other equipment components.

4. BLUETTI APP

Search for 'BLUETTI' in the App Store (for iOS devices) or Google Play (for Android devices) to download the BLUETTI App to remotely control your AC200MAX.

The AC200MAX supports Bluetooth control. In order to access the AC200MAX, please launch the BLUETTI App once downloaded and installed, and tap 'Bluetooth CONNECT' to register your BLUETTI AC200MAX.

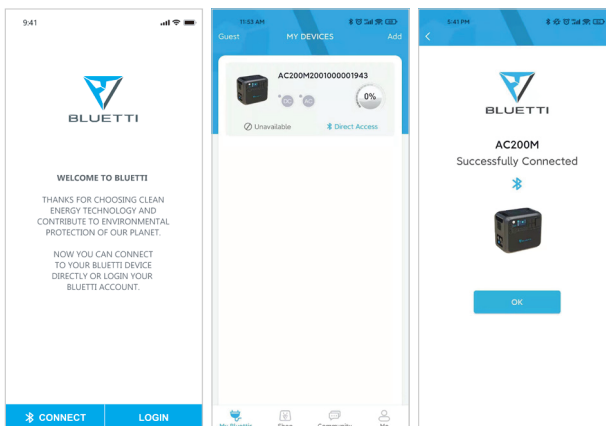

View the basic information of your AC200MAX on the phone after the unit

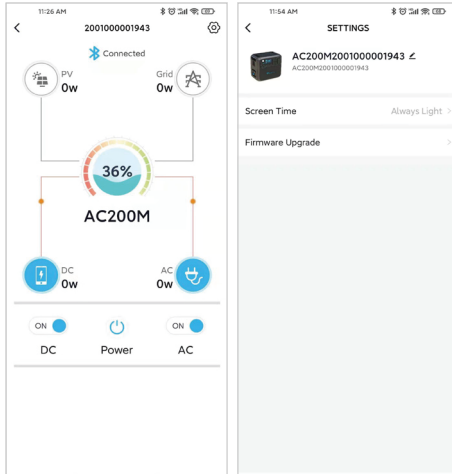

connects with the App successfully. Press the 'gear icon' to customize the current working mode and parameters of your AC200MAX under 'Settings'.









NOTE: Please keep your phone no more than 5m/16.4ft away from the AC200MAX during the update.



5. IN THE BOX

Standard Accessories

No.	Category	Quantity
1	 AC200MAX Power Station	1
2	 Adapter For AC charging.	1

3	 <p>PV Charging Cable (XT90 - MC4) For solar charging, up to 15A, 900W.</p>	1
4	 <p>Car Charging Cable (XT90 - Cigarette Lighter Port) Charge AC200MAX by car.</p>	1
5	 <p>Multifunctional DC Charging Cable (XT90-Aviation) Expand the charging methods via PV input port.</p>	1
6	 <p>User Manual</p>	1
7	 <p>Warranty Card</p>	1
8	 <p>Certificate of QC PASS</p>	1

Optional Accessories

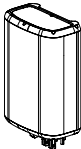
No.	Category	Type
9	 <p>Lead-acid Battery Charging Clamp Charging AC200MAX through lead-acid battery only. DO NOT charge the lead-acid battery via this cable.</p>	Optional Input Cable
10	 <p>AC Input Connector (XT90 - DC7909) Charging AC200MAX via a second AC adapter from the PV input port.</p>	
11	 <p>12V/30A Output Bundle (Aviation - XT60, XT60 - SPC45) Perfect for RV.</p>	Optional Output Accessories
12	 <p>D300S PV Step Down Module Step down the voltage of solar panels (especially rigid panels) to meet the AC200MAX solar input standard.</p>	Optional Accessories

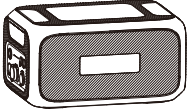
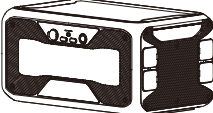
<p>13</p>	 <p>B230 Battery Module Extra 2048Wh capacity, up to 2 B230 can be connected to AC200MAX.</p>	<p>Optional Accessories</p>
<p>14</p>	 <p>B300 Battery Module Extra 3072Wh capacity, up to 2 B300 can be connected to AC200MAX.</p>	<p>Optional Accessories</p>

6. FEATURES

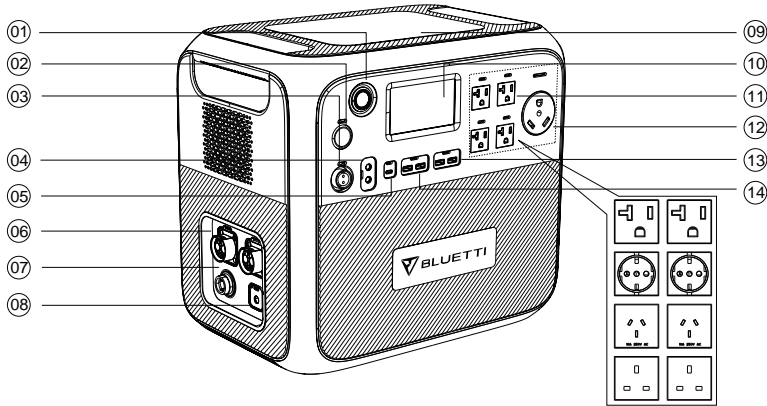

01 Power Button

Long/Short press to turn ON/OFF the AC200MAX.

02 DC 12V/10A cigarette lighter port

Output port for devices with corresponding plug such as vehicle-use vacuum, refrigerator.

03 DC 12V/30A output

Special 30A output port adapted to most appliances, perfect for RV.

04 DC 5521 12V/10A output x 2pcs

Traditional ports for routers/cameras, old laptop etc.

05 USB-C 100W output

Output port to charge most devices at 100W Max, such as Pixel Phone, Macbook Pro.

06 Battery extension port x 2pcs

The port to connect AC200MAX with B230 or B300 battery pack.

07 DC input port

The port to connect with solar panels for solar charging, or with extra cables for car, lead-acid battery, and extra AC adapter charging.

08 AC input port

Charging via the AC adapter or D050S.

09 Wireless charging pad 15W x 2pcs

Place your phone(if wireless charging supported) on the top of the AC200MAX horizontally, and turn on the DC in mainpage on screen.

10 Interaction LCD Touchscreen

Control the unit with finger touch.

11 US AC output x 5 pcs(EU/UK AC output x 4pcs)

Standard AC receptacle: widely used in 100-120V areas, generates the almost same AC power as a household wall outlet. High-voltage area uses special sockets.

12 US AC TT-30

NEMA TT-30: connector which is the 120V/30A recreational vehicle standard, also known as RV 30. The TT-30 receptacle is commonly available in nearly all RV parks in the United States and Canada.

13 USB-A 5V/3A output x 2pcs

Classic USB-A ports.

14 USB-A 18W output x 2pcs

Quick charge USB-A ports.

7. LET'S GET STARTED

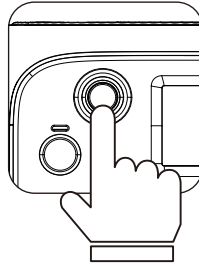

- (1) Startup: short press the power button to turn it on; the indicator light is on.
- (2) Shutdown: press and hold the power button for several seconds, and the indicator light will be off.

Troubleshooting	The LED indicator lamp status
BMS Over-current or short circuit protection	The indicator light flashes and turns off.
BMS Startup timeout	The indicator light flashes and does not turn off.
Normal startup	The indicator light turns on.
Normal shutdown	The indicator light turns off.

- (3) DC power switch and AC power switch are integrated into the interaction LCD screen (Homepage), press the 'DC ON/OFF' or 'AC ON/OFF' on the screen to turn on/off the DC/AC output.

8. TOUCHSCREEN

Interaction LCD screen (Information Vision) supports the below functions:

- (1) View real-time display of voltage, current, power, temperature, and the state of charge and discharge.
- (2) Adjust the output voltage, frequency, charging mode, power consumption mode, and time information in the setting column.
- (3) Operate with fingers due to resistive touchscreen.

(4) View fault history, BMS, DSP, ARM, HMI hardware version.

9. TOUCHSCREEN OPERATION

Note:

● The LCD touch screen is resistive. It is recommended to lightly tap or touch the screen with fingers till it 'beeps'.

● To maximize the lifespan of the LCD screen, please avoid direct sunlight.

(1) When pressing the power button, the main page will display as Homepage.

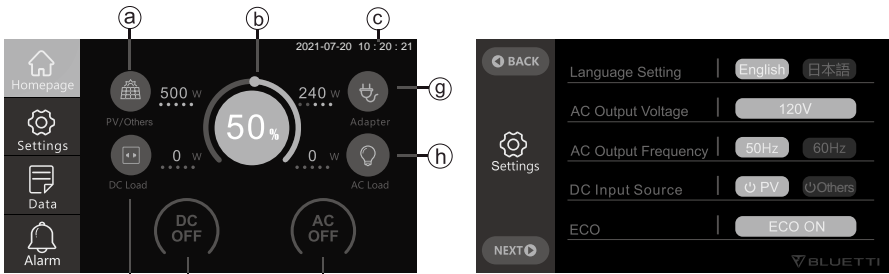

(Homepage)

(Figure 1)

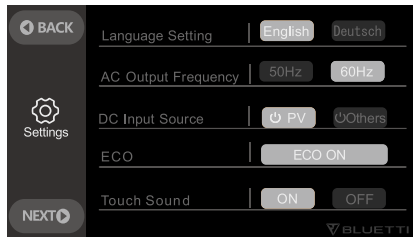

(220-240V Version)

- a. PV/Others charging Info
- b. BMS Info
- c. Date/Time
- d. DC Load Info

- e. DC ON/OFF Switch
- f. AC ON/OFF Switch
- g. Adapter Charging Info
- h. AC Load Info

Bluetooth Pairing Guide

Scope of Application

This guide applies to BLUETTI products that support Bluetooth.

Function

- All BLUETTI products support Bluetooth 5.0. Built-in low energy Bluetooth modules can interact with other Bluetooth devices within a range of 10m.
- Pair your device with BLUETTI app, remotely monitor and control it on your phone or other smart devices.
- For BLUETTI products with LCD screen, you can enable and disable Bluetooth on the screen: 'Setting' - 'Bluetooth' - 'ON' or 'OFF'.

For those without LCD screen, you can do that by pressing the Bluetooth button.

- Transferable Data:

(1) Display Data

- a) AC On/Off Status
- b) Charge and Discharge Power
- c) Model Code
- d) Alarm History
- e) Firmware Version
- f) SOC (State of Charge)

(2) Control Data

- a) AC and DC ON
- b) System Parameters Setting (E.g., AC output frequency)
- c) Charge and Discharge Time (Available for particular models)
- d) Empty and Full Capacity Setting (Available for particular models)
- e) OTA (Over-the-air) Firmware Upgrade

Bluetooth Pairing

- Download the BLUETTI app from App Store or Google Play. Follow the instructions to register your BLUETTI product.
- Power on BLUETTI product and wait for Bluetooth initialization (10s).
- Bluetooth of BLUETTI product is activated by default. Open BLUETTI app, search the Bluetooth name (Model + SN) and pair.

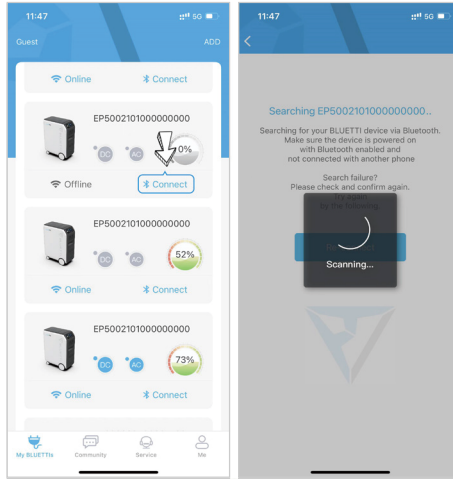

- After pairing, follow the instructions to monitor and control the BLUETTI product.
- If you want to disable the Bluetooth of BLUETTI product,
 - (1) Power it off.
 - (2) Disable Bluetooth on the LCD screen.

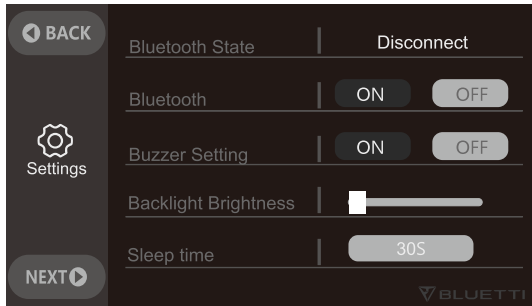

Notes

- If Bluetooth of BLUETTI product is not found, check its Bluetooth status.
- If Bluetooth connection is poor, please try:
 - 1) Get closer to BLUETTI product and move the obstacles between it and your phone.
 - 2) Use the unit as far away as possible from a microwave oven, ticket gates, other Bluetooth device or places that generate electromagnetic radiation.
- If the symptom persists, restart BLUETTI product and reconnect.
- Keep BLUETTI product surface clean, as it will affect the performance of Bluetooth connection.

(2) Tap 'Settings' on the homepage to enter the setting section (Figure 1).

kindly Note: Please enter the setting section to set the date and time according to the local time zone, and check the output voltage, frequency, and other parameters for the first-time startup.

Voltage and Frequency Reference:

JP: 100V/50Hz

US: 120V/60Hz

EU: 230V/50Hz

UK: 230V/50Hz

DC Input Source: Select the right method you choose to charge AC200MAX.

ECO Mode: When it's on, the AC power will automatically turn off over 4 hours low ($\leq 50W$) or no load to save power drain.

Press the 'Next' to enter the data setting (Figure 2):

Backlight Brightness and Sleep Time: Set the proper value as your need for power saving.

Date and Time: 2000-00-00; 00: 00: 00, make adjustments to set it right.

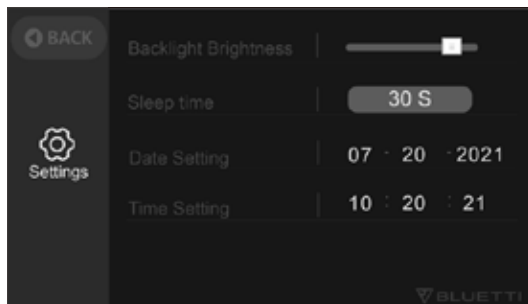

(Figure 2)

(3) Back to the Homepage, tap the 'Data' to enter the Data page (Figure 3).

- Tap the 'product Info' to view the product model, software version, BMS version, etc.
- Tap the 'Inverter & Charger Info' to view input and output information which can also be accessed directly from the shortcut on the Homepage.
- Tap the 'BMS Maintenance' to view the battery status, which can also be accessed directly from the shortcut on the Homepage.

- Tap the 'Fault History' to view all fault messages.

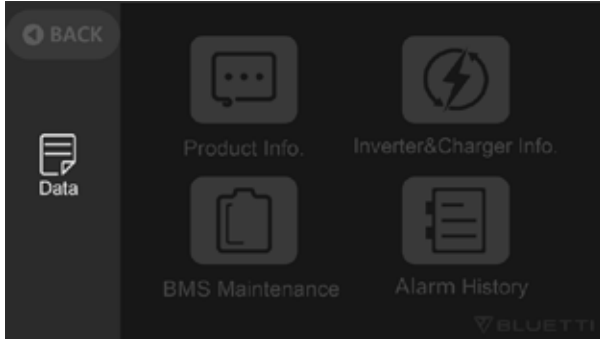

(Figure 3)

(4) Tap the 'Alarm' on the Homepage to view the current error message: the fault indicator will display orange if a fault occurs.

10. CHARGING

(1) From the AC wall outlet

- Turn the AC200MAX ON and connect the adapter plug to the wall outlet, the other end to the AC input port. Charging will automatically stop when it gets fully charged.

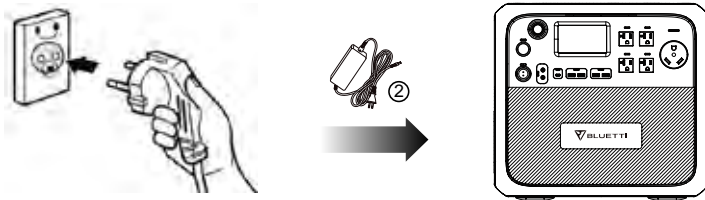

(2) From the solar panels

- Connect the solar panels (in series or parallel) with Open Circuit Voltage range 10V-145V.
- Connect the solar panel to AC200MAX via the solar charging cable. (Standard Accessory 3 to Accessory 5)
- Charging: AC200MAX will be activated when the solar charging system is set up successfully.
- The max input current of solar charging: $15.2A \pm 0.3A$, the over-current of

solar charging will be wasted.

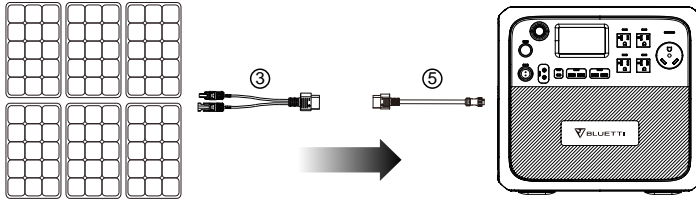

(3) From the car cigarette lighter port

- Connect the AC200MAX to the cigarette lighter port of the car via the car charging cable.
- Enter the setting section as Figure 1, set DC input source to 'Others'.
- The input current of car charging requirement: 8.2A

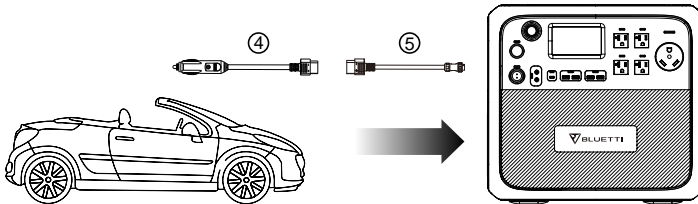

(4) From the generator (gasoline, propane, or diesel)

- Connect the AC adapter input plug to the generator and the output to the AC charging port of AC200MAX.
- Press the power button; the product will start charging. When it gets fully charged, the charging will automatically stop.

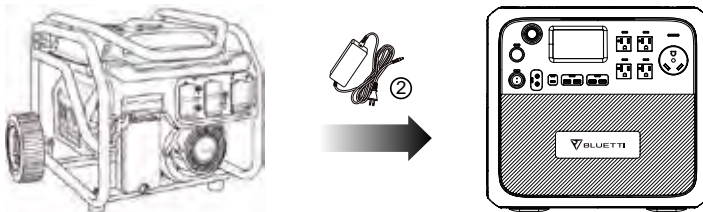

(5) From the lead-acid battery

- Connect the AC200MAX with a lead-acid battery via the charging cable (Accessory 9).

Note: pay attention to distinguishing the positive and negative poles of the battery. The red end indicates the positive pole.

- Enter the setting section as Figure 1 to set the DC input source to 'Others' to activate lead-acid battery charging, with the max current of 8.2A.

Note: Accessory 9 is for charging the AC200MAX only. DO NOT use it for other purposes, like charging the lead-acid battery. Any injury or damage caused by failure to follow instructions will NOT be compensated.

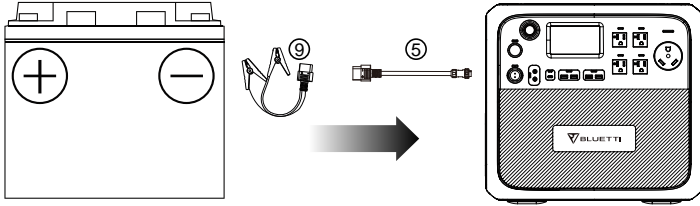

(6) Dual Charging

- Set the 'DC Input Source' to 'PV' to achieve AC + PV Dual Charging.
- Set the 'DC Input Source' to 'Others' to achieve AC + Adapter/Lead-Acid Battery Charging.

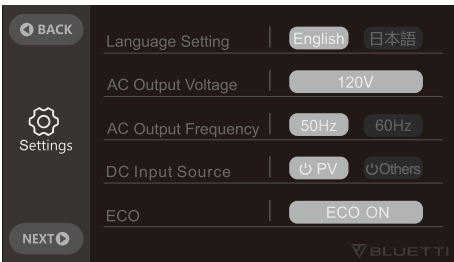

(100-120V Version)

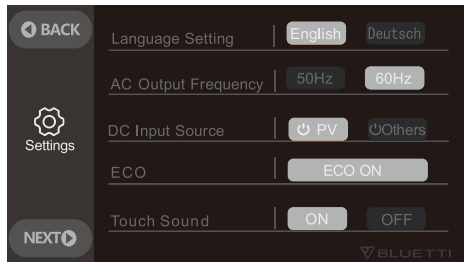

(220-240V Version)

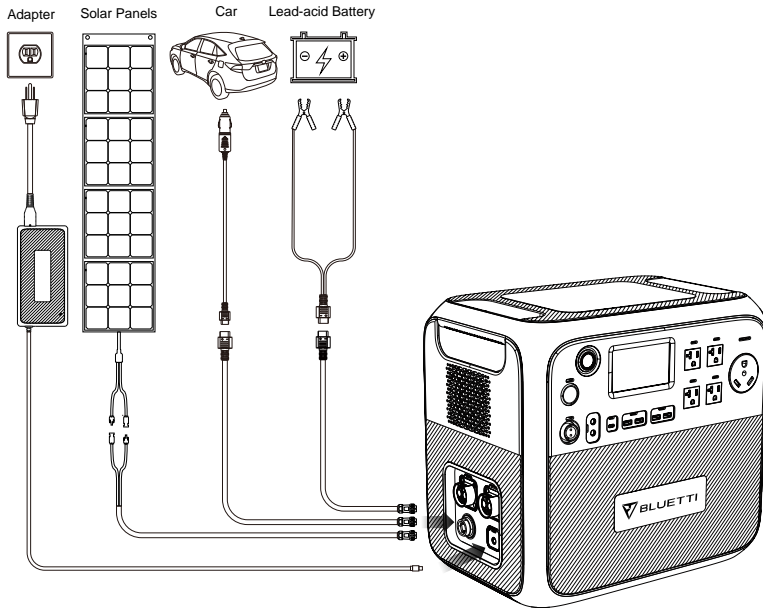

(AC200MAX Dual Charging System)

11. DISCHARGING

- (1) Turn on the 12V/30A, 12V/10A/, cigarette lighter, USB-A and USB-C output ports: press the power button, enter the homepage and tap the 'DC ON/OFF' and confirm.
- (2) Turn off the DC output: tap the 'DC ON/OFF' and confirm.
- (3) Turn on the AC output: press the power button, enter the homepage, tap the 'AC ON/OFF' and confirm.
- (4) Turn off AC output: tap the 'AC ON/OFF' and confirm.

12. APPLICATION SCENARIO

(1) Outdoor

Car equipment: car fridge, car vacuum cleaner, and other car equipment;

Camping equipment: garden electric tools (power tools such as blowers, lawnmowers, electric drills, electric saws), BBQ grills, LED lights, etc.

(2) Indoor

Refrigerator, kitchen devices such as kettle, toaster, blender, coffee maker, rice cooker, laptops, phones, lighting, etc.

13. EXAMPLES OF LOADS

(1) Most electrical appliances in the market apply to the specifications of 12V/30A (XT60 or SPC45), 12V/10A, cigarette lighter, USB-A, and USB-C output ports of the AC200MAX. But still, the charging of some products may activate the over-current protection if it generates an instantaneous high current at the moment of starting.

(2) The AC200MAX can power electrical products with 2200W or less rated power. Though the figure is under 2200W, overload protection will still be activated when the appliance generates a massive instantaneous start-up power. Therefore, it's recommended to apply the AC200MAX to electrical products with lower-rated power.

(3) If an output over-current, overload, or short circuit occurs, the AC200MAX will turn off the corresponding output port. Then it will automatically start again (at an interval of 20s). Suppose there is still an over-current, overload, or short circuit, the output port will be locked and it then needs manual troubleshooting. If the output repeatedly stops, turn the equipment off. Please get in touch with the seller or maintenance group first for professional help.

(4) When the battery level drops to 0%, the DC and AC output will automatically turn off, and ONLY when the battery power is recharged to more than 5%, the DC and AC output will be turned on again. Please check the battery level before using the AC/DC output to protect and enhance battery cycle life.

(5) This AC200MAX supports charging and discharging simultaneously, and please keep the equipment laid flat during use, charging, and discharging.

14. AC200MAX + B230 CONNECTION Capacity Expansion

- AC200MAX can expand the capacity by 1-2 B230 battery pack to 4096 - 6144Wh.
 - AC200MAX can expand the capacity by 1-2 B300 battery pack to 5120 - 8192Wh.
- Please refer to the bluetti support youtube channel for detailed installation instructions.

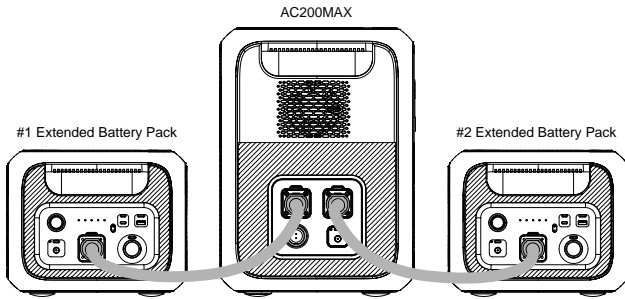

● Battery Expansion Instruction

Hot-swappable B230/B300 Expansion Battery Modules are designed to achieve capacity backup with easy plug-on P090D Battery Expansion Cable.

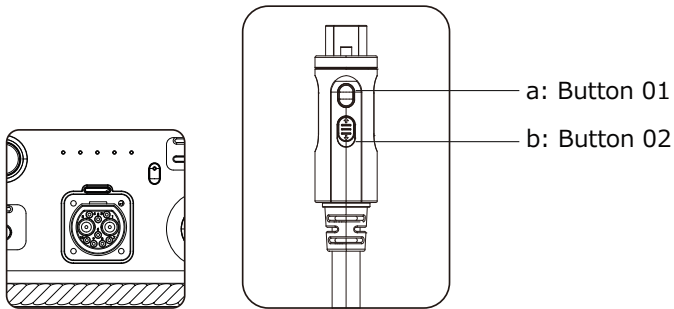

- a: Press to turn ON/OFF the Expansion Battery Function.
- b: Switch to LOCK/UNLOCK the cable with AC200MAX.
- c: Turn On B230 or B300 battery module.

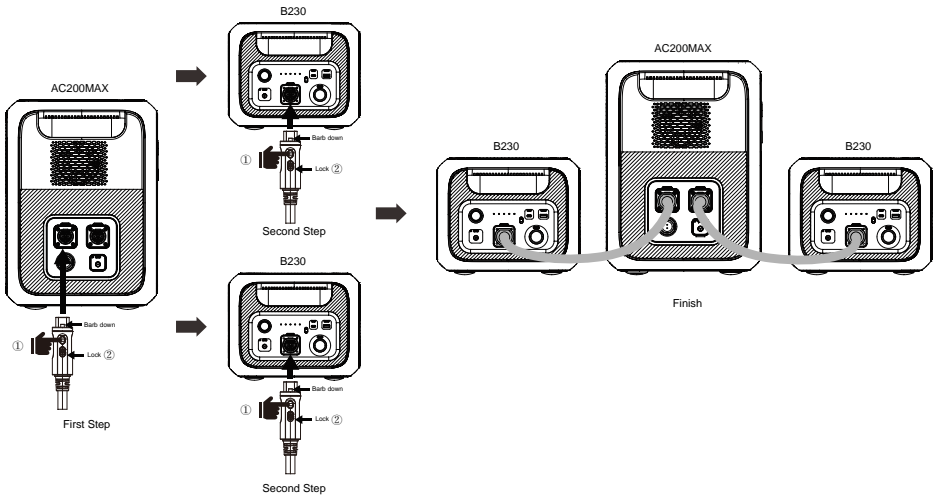
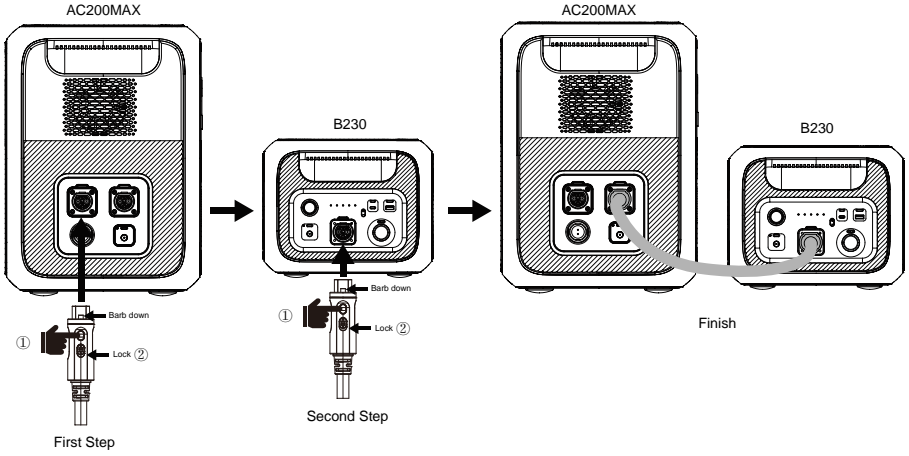

AC200MAX Capacity Extended Mode

15. ESTIMATION OF OPERATING TIME

Smartphone 175-200Times 10W	LED Light Bulb Around 75-85hrs 20W	Television Around 20-22hrs 75W
Electronic Tools Around 19-20hrs 80W	Refrigerator Around 17-19hrs 90W	Slow Cooker Around 8-9hrs 200W

$2048Wh \times DOD \times \eta \div (\text{load power}) = \text{charging time}$

Note : DOD is the battery discharge depth, η is the local inverter efficiency.

And the units of load power and charging time are Watt and Hour. DOD=90%, $\eta =90\%$.

16. TECHNICAL SPECIFICATIONS

Model No.	AC200MAX	
Net Weight	28.1kg (61.9lbs)	
Dimensions	420*280*386.5mm (16.5*11.0*15.2in)	
Charge Temperature	0-40°C (32-104 °F)	
Discharge Temperature	-20-40°C (-4-104 °F)	
Working Environment Humidity	10-90%	
Capacity	2048Wh (40Ah)	
Battery Type	LiFePO4	
Standard Battery Voltage	51.2VDC	
Category	Rated	Note
AC Output		

Power of Output	100V	2000W	JP
	110V	2200W	
	120V	2200W	US
	220-240V	2200W	UK,EU
Over-load	100V	2000W<load<2500W, 2min ; 2500W<load, 8~10S	Error Range : ± 30W ; Clear the alarm history and reboot the unit.
	110V	2200W<load<2750W, 2min ; 2750W<load, 8~10S	
	120V		
	220-240V		
Surge	4800W		100ms
Frequency	50/60Hz ± 0.5Hz Default @60Hz		Frequency can be tweaked to 50 or 60Hz.
Inverter Efficiency	90%		/
Short-circuit Protection	Yes		/
Over-temperature Protection	80°C± 2		Recover Temp: 75°C± 2(for hardware)
AC & DC will be turned off when SOC reaches 0%			
DC Output			
Cigarette Lighter Port *1	Voltage	12V	Share 10A current with 2* DC5521 ports.
	Current	10A	
	Over-load Power	145W	2s, Turn off output function.
	Short-circuit Protection	Yes	Turn off all DC output ports.
DC5521 *2	Voltage	12V	Share 10A current with cigarette lighter port.
	Current	10A	
	Over-load Power	145W	2s, Turn off output function.
	Short-circuit Protection	Yes	Turn off all DC output ports.

RV *1	Voltage	12V	/
	Current	30A	
	Over-load Power	400W	2s, Turn off output function.
	Short-circuit Protection	Yes	Turn off all DC output ports.

Note:

a: 30A Max. current for all DC output ports.

b: The cigarette lighter port will be shut off once overloaded.

c: 12V/30A port will be shut off when overloaded again.

USB-A *2	Voltage	5V	/
	Current	3.0A	3A for both
	Short-circuit Protection	Yes	Recover automatically
USB-A Quick *2	Voltage	5-12VDC	Support QC3.0
	Current	3A * 2	18W * 2, MAX
	Short-circuit Protection	Yes	/
USB-C *1	Standard	PD3.0 (Max.100W)	/
	Specs	5VDC, 3A, 15W Total	/
	Short-circuit Protection	Yes	/
Wireless Charging *2	Standard	Support QI protocol	Please place the device supporting wireless charging on the charging pad horizontally.
	Power	5/7.5/10/15W * 2	

Solar Input

Power of Input	900W	/
Over-voltage Protection	145VDC	/
MPPT Voltage Range	10-145VDC	/
Current	15A	/

MPPT Quantity	1/1	/
AC Adapter Charging (On PV input port)	500W MAX	/
	7-8A	/
Car Charging	11.5-14.5V	Set DC input source on screen : Others 12V Lead-acid Battery: 11.5V ± 0.2V ; 24V Lead-acid Battery: 23V ± 0.2V
	23-29V	
	8A	

Note : PV Input, Car Charging, and additional Adapter shares the same Aviation Port.

AC Charging Adapter

Input Voltage	100-240VAC	/
Voltage Range	58.8V	/
Max. Charging Power	500W	/

Note:

a: AC200MAX can be automatically activated (turn the unit ON without pressing the power button from POWER OFF) via solar power. Please unplug the DC input cable if you want to disable the auto-activation.

b: AC200MAX cannot be activated via the adapter.

c: Simultaneous charging&discharging supported.

BLUETTI APP(Bluetooth)

Firmware Update	5m/16.4ft	/
Wireless Connect	10m/32.8ft	/

17. TROUBLESHOOTING

Error Code	Description
001	PV Over Voltage
004	DC Output Short Circuit
005	Adapter Over Voltage
006	Adapter Low Voltage
007	Adapter Relay Error
008	Adapter Over Current

010	USB/USB-C/PD Over Current
011	12V/10A Over Current
012	12V/30A Over Current
014	DC Start Failure
015	DC Output Relay Error
016	BUS Start Failure
017	Inverter Start Failure
018	BUS Low Voltage
019	BUS High Voltage
020	Inverter Low Voltage
021	Inverter High Voltage
022	Inverter Low Frequency
023	Inverter High Frequency
025	Battery High Voltage
026	Battery Low Voltage
027	Battery Unconnected
028	Fan Error
029	NTC Error
030	Calibration Error
031	Inverter Over Load
032	Inverter Short Circuit
033	DSP Communication Error
034	BMS Communication Error
035	EEPROM Read_write Error
036	Parameters of Control Module Error
041	BMS Temperature Error
042	BMS Over Voltage
043	BMS Low Voltage
044	BMS Over Current
045	BMS Pre-charge Failure
046	BMS Output Short Circuit
051	AC Output Locked
053	USB/USB-C/PD Locked
054	12V/10A Locked
055	12V/30A Locked

18. FAQ (Frequently Asked Questions)

- How to claim the warranty?

Please write your after-sales requirements on the warranty card and send it to the vendor.

- Can the unit be upgraded?

When AC200MAX connects with BLUEETTI App via Bluetooth, the firmware including ARM, DSP, HMI, and BMS can get upgraded online through OTA.

- Can it charge and discharge at the same time?

Yes, it supports pass-through charging. Please keep the equipment laid flat during use, charging, and discharging.

- How to store the AC200MAX?

We recommend charging the unit to 60-80% SOC every 3 - 6 months to extend the battery life.

19. DECLARATION

- Please note that specifications and appearance are subject to improvement without prior notice.

- The company shall not be liable for any damage caused by force majeure, such as fires, typhoons, floods, earthquakes, or the user's intentional negligence, misuse, or other abnormal conditions.

- The company shall not be liable for any accidents or damages caused by failure to follow the precautions in the instruction manual.

- This product is not suitable for relevant equipment or machines involving personal safety, such as automatic energy devices, Hi-Fi player devices, emergency medical devices, etc., or for appliances requiring demanding power reliability and security, such as aerospace equipment, trunk communication equipment, nuclear control equipment, and medical equipment. Please confirm the applicability of this product in advance.

20. FCC WARNING

This device complies with Part 15 of the FCC Rules.

Operation on the product is subject to the following conditions:

- (1) this device may not cause harmful interference.
- (2) this device must accept any interference received, including interference that may cause undesired operation.

Any changes or modifications not expressly approved by the party responsible for compliance could void the user's authority to operate the equipment.

NOTE: This equipment has been tested and found to comply with the limits for a Class B digital device, pursuant to Part 15 of the FCC Rules. These limits are designed to provide reasonable protection against harmful interference in a residential installation. This equipment generates, uses, and can radiate radio frequency energy, if not installed and used in accordance with the instructions, may cause harmful interference to radio communications.

However, there is no guarantee that interference will not occur in a particular installation.

If this equipment does cause harmful interference to radio or television reception, which can be determined by turning the equipment off and on, the user is encouraged to try to correct the interference by one or more of the following measures:

- Reorient or relocate the receiving antenna.
- Increase the separation between the equipment and receiver.
- Connect the equipment into an outlet on a circuit different from that to which the receiver is connected.
- Consult the dealer or an experienced radio/TV technician for help.

FCC Radiation Exposure Statement

This equipment complies with FCC radiation exposure limits set forth for an uncontrolled environment. This equipment should be installed and operated with a minimum distance of 0.65ft between the radiator and your body.

Manufacturer:	
Company name:	Shenzhen PowerOak Newener Co.,ltd
Address:	F19, BLD No.1, Kaidaer, Tongsha Rd No.168, Xili Street, Nanshan, Shenzhen, China
Company registration No.:	91440300071761480R
VAT No.:	
Tel:	0086-755-23705980
E-Mail:	feedback@poweroak.net

EU Kontakt:	
Company name:	Shenzhen PowerOak Newener Co.,ltd
Address:	Lindwurmstr. 114, 80337 Munich, Germany
Company registration No.:	HRB 261852
VAT No.:	DE342113007
Tel:	0049 421 87852946
E-Mail:	logi@bluetti.de

UK Kontakt:	
Company name:	POWEROAK ENERGY UK CO., LTD
Address:	Unit 2 Northgate, Bolsover Busines Park, Bolsover, S44 6BD
Company registration No.:	396829822
VAT No.:	
Tel:	0044-7860 8449 32
E-Mail:	poweroak.eu@bluetti.com

