

WAGNER PRESENTS

# Contractor 2023

PRODUCT NAVIGATION



**BE UNSTOPPABLE!**

**WAGNER**



Facades, walls, furniture, doors, steel structures, mobile phones, car wheel rims and controls, leather sofas and radiators – there are hardly any objects which cannot be surface finished. Clearly along with function, durability and attractiveness, the surface of an object is its definition. Your customers, as professionals all want to achieve a high level quality finish. WAGNER can help support your business with high quality professional equipment which is both time saving and cost effective.

Different application areas characterise the product range of the contractor sector: **SMALL PROJECTS:** Spraying units for repair and touch-up work. Ideal for all projects in the renovation and new construction sector when using the unit irregular and rare. Good price-performance ratio.

**BUILDING TRADE:** Units for Painters and Plasterers. Ideal for all interior and exterior applications, for a wide range of surfaces, walls, ceiling radiators and door frames. Powerful screw pumps for heavy aggregated material.

**WOOD AND METAL WORK:** Spray units for painting a wide range of objects such as stairs, floors, kitchens, furniture and railings with water diluted or solvent based paints.

## WAGNER GROUP WORLDWIDE

- Around 2,000 employees
- 19 operational companies, including 5 production plants
- Around 400 international agencies
- A 1,500 m<sup>2</sup> Technology Centre in Markdorf and a further 7 throughout the world
- Worldwide service directly on site



# INNOVATION SINCE 1947

Perfect surfaces and added value are our passion. Bringing colour, protection and function to surfaces is our mission. We dedicate all of our technical expertise to enhance our products, and support you with a personal level of service. Using innovative Technologies and highly efficient, reliable and user-friendly solutions, we are constantly setting new standards in surface technology.

**CORROSION AND STRUCTURAL PROTECTION:** Applying protective coatings with airless technology and electric or petrol-driven piston pumps.  
**PREPARING:** Power tools for the removal of paint and wallpaper.

The range for each stretches from small entry level units through all rounder units right up to specialised plant. Comprehensive accessories guarantee an optimal match to the object in question.

WAGNER develops numerous product innovations in close contact with users, paint manufacturers and scientific institutions. Our 1500 square metre technology centre in Markdorf plays an important role in practical research and relaying knowledge. For example interregional master classes to consolidate the training for the painting trade have taken place here for years. We provide a comprehensive Service Network and also a large number of specialist advisers to help you in an instant.

MATERIALS	Water and solvent-based paints, lacquers, oils, separating agents	Synthetic resin varnishes, PVC lacquers, 2K lacquers	Primers, fillers	Fire protection, rust protection paints	Emulsion and latex paints, adhesives, sealants	Exterior paints, roof coatings, floor coatings, textured paint	Structural waterproofing, bituminous coatings	Filler	Plaster	Injection
FinishControl 3500	🏠	🏠	🏠		🏠					
FinishControl 5500	🏠	🏠	🏠		🏠					
FineCoat 9700	🏠	🏠	🏠							
FineCoat 9900 Plus	🏠	🏠	🏠							
SuperFinish 23 Pro HEA	🏠	🏠	🏠	🏠	🏠	🏠				
SuperFinish 23 Plus HEA	🏠	🏠	🏠	🏠	🏠	🏠				
SuperFinish 23 Plus Airless Enamel	🏠	🏠	🏠	🏠	🏠	🏠				
SuperFinish 23 Plus TempSpray	🏠	🏠	🏠	🏠	🏠	🏠				
SuperFinish 23 Plus AirCoat Enamel	🏠	🏠	🏠	🏠	🏠	🏠				
SuperFinish 23 CR	🏠	🏠	🏠	🏠	🏠	🏠				🏠
SuperFinish 33 Pro	🏠	🏠	🏠	🏠	🏠	🏠				
SuperFinish 33 Plus	🏠	🏠	🏠	🏠	🏠	🏠				
PowerPainter 90 Extra	🏠	🏠	🏠	🏠	🏠					
ProSpray 3.20 HEA	🏠	🏠	🏠	🏠	🏠					
ProSpray 3.21 HEA	🏠	🏠	🏠	🏠	🏠					
ProSpray 3.25	🏠	🏠	🏠	🏠	🏠	🏠				
ProSpray 3.31	🏠	🏠	🏠	🏠	🏠	🏠	🏠			
ProSpray 3.39 Emulsion	🏠	🏠	🏠	🏠	🏠	🏠	🏠	🏠		
ProSpray 3.39 Filler	🏠	🏠	🏠	🏠	🏠	🏠	🏠	🏠		
HeavyCoat 750 E/G & E SSP				🏠	🏠	🏠	🏠	🏠		
HeavyCoat 950 E/G & E SSP				🏠	🏠	🏠	🏠	🏠		
HeavyCoat 970 E/G & E/G SSP				🏠	🏠	🏠	🏠	🏠		
PlastCoat HP 30					🏠	🏠	🏠	🏠		
PlastCoat 1030 E								🏠	🏠	



Small projects up to 50 m<sup>2</sup>



Residential 50 m<sup>2</sup> - 200m<sup>2</sup>



Large residential 200 m<sup>2</sup> - 800m<sup>2</sup>



Commercial more than 800m<sup>2</sup>



Suitable material



Suitable material - additional accessories are needed



To our SprayGuides:  
[go.wagner-group.com/sprayguide](http://go.wagner-group.com/sprayguide)

## MACHINE & MATERIAL PERFECTLY MATCHED

The extensive WAGNER SprayGuide offers you test reports from well-known material manufacturers for use with WAGNER spray machines.

Visit [go.wagner-group.com/sprayguide](http://go.wagner-group.com/sprayguide) to find out how to set up your machine to match the material you are using, and which paints and lacquers can be sprayed most effectively with WAGNER technology.

- ➔ Search by material type
- ➔ Search by material manufacturer
- ➔ Search by WAGNER machine and systems



Anyone purchasing a WAGNER paint sprayer automatically receives a three-year manufacturer's warranty. But we can do more: If you register online, you can extend this warranty for a further two years, free of charge!

[go.wagner-group.com/3plus2](http://go.wagner-group.com/3plus2)



## FURTHER TRAINING IN OUR MODERN TRAINING CENTRE

Equipment technology represents the future of professional painting and decorating within the context of normal, efficient, high-quality site work. This is why it is particularly important to us to not only provide you with the technology but also to convey the corresponding know-how. After all, even the very best products only create the best surface when used in combination with specialist professional knowledge.

Whether user, plant manager, material manufacturer or sales partner - the new WAGNER ACADEMY offers every target group high-quality training modules for professional and personal further education.

THE TRAINING CENTRE IN MARKDORF ON LAKE CONSTANCE HAS AT ITS DISPOSAL:

- Three seminar rooms with state-of-the-art presentation and conference technology
- Practical zone with different, mobile demo areas
- Technical centre for service issues
- Painting booth with extraction system

	BASIC CERTIFICATION	ADVANCED CERTIFICATION	EXPERT CERTIFICATION
<b>WAGNER training courses to choose from</b>	<ul style="list-style-type: none"> <li>• Mechanical paint application from paint to plaster</li> </ul>	<ul style="list-style-type: none"> <li>• Paint materials</li> <li>• Interior wall paint</li> <li>• Exterior &amp; building protection material</li> <li>• Fillers &amp; plaster</li> </ul>	<ul style="list-style-type: none"> <li>• HVLP &amp; XVLP technology</li> <li>• SuperFinish technology</li> <li>• ProSpray technology</li> <li>• HeavyCoat technology</li> </ul>
<b>Duration</b>	1 day (50 % Theory, 25 % Demo, 25 % Training)	1 day (50 % Theory, 25 % Demo, 25 % Training)	1 day (45 % Theory, 10 % Demo, 45 % Training)
<b>Prior knowledge</b>	none	WAGNER Basic Operator Training (recommendation)	WAGNER Advanced Operator Training (recommendation)



You can find training dates online at [go.wagner-group.com/academy-contractor](http://go.wagner-group.com/academy-contractor). Registration and further information can also be found on our website.

**We come to you!**  
 All training courses can also be held conveniently at your premises. Please contact us at: [Academy.DF@wagner-group.com](mailto:Academy.DF@wagner-group.com) or call +49 (0) 7544 505 1602

## HVLP/XVLP TURBINES

### High air volume – low air pressure

Are you looking for a versatile spray device that offers a wide range of applications for improvement and renovation work on small to medium-sized construction sites? Then the modular low-pressure spray systems with HVLP- and XVLP technology (Xtra Volume Low Pressure) from WAGNER are perfect for you – especially in terms of quality, functionality and value for money. Low-pressure spraying involves working with a large air volume and a low air pressure (up to 0.7 bar) – which results in a high working speed and minimal overspray.



#### Particularly powerful and flexible:

In low-pressure spraying, the atomising air generated in the turbine flows through an air hose to the paint container on the spray gun, where it then builds up pressure. This delivers the coating material through the material tube to the nozzle and atomises it with the remaining air. The spray devices of the WAGNER XVLP series offer much better atomisation performance compared to other lower-pressure devices (HVLP), thanks to a 60 percent greater air volume and 30 percent more surface coverage.

#### Well-equipped for daily use on construction sites:

The modular system consists of a turbine and various spray attachments which enables the application of wood stains, varnishes and lacquers through to emulsions with professional quality. Thanks to the practical Click & Paint function, the attachments can be changed with a simple movement. The XVLP devices from WAGNER are perfect when starting to use spray equipment or to add to the range of devices available on site.

#### 1. LESS OVERSPRAY

The HVLP- and XVLP spray devices combine the positive properties of low pressure with those of a high-pressure procedure, i.e.: Less overspray and fine atomisation result in an optimised consumption of material.

#### 2. OPTIMAL ADJUSTMENT OPTIONS

The volume of air and material can be perfectly adjusted directly on the gun and therefore quickly changed to match various objects using a rotary control.

#### 3. INNOVATIVE NOZZLE TECHNOLOGY

The XVLP spray devices combine the properties of low pressure with those of a high-pressure procedure. The combination of a large air volume and innovative, Visco slot nozzle technology enables a high working speed with excellent surface quality even with highly viscous paint.

#### 4. A VARIETY OF POSSIBLE USES

The devices are especially versatile thanks to three spray attachments – StandardSpray, FineSpray and WallSpray – which are ideal for handling various materials. Thanks to the practical Click & Paint function, the spray attachments can be changed with a simple movement.

## APPLICATION AREA ADVANTAGES HVLP AND XVLP TECHNOLOGY

Lacquers	Enamels		Emulsions
	standard	high-viscosity	
HVLP			
XVLP			

## ADVANTAGES

- Easy to use
- Spray pattern adjustable to object
- Spraying of undiluted materials
- All settings directly on the gun
- Quick material change with Click & Paint system (XVLP)

# FINISHCONTROL 3500 SPRAYPACK

All-rounder for small projects: The entry-level answer for professional coating with spray technology

- **Universally suitable:** for use with varnishes, lacquers and emulsion paints, thanks to a modular spraying attachment system for simple material changes
- **Total control:** directly on the gun
- **Handy:** the smallest in class accompanies you on all job sites with a convenient carrying strap
- **Flexible:** ideal for repair jobs and restoration projects
- **Compact and portable:** the practical transport case offers space for the machine and two additional spraying attachments, which can be transported upright and filled

#### The trend-setting Visco nozzle

**technology:** produces a particularly high-quality spray pattern. This is achieved thanks to the flat jet delivered by the slot nozzle which also ensures a high working speed

**Click & Paint System:** the paint-carrying spray attachment can be easily removed from the gun for easy cleaning. Additional spray attachments allow you to work with different materials and change colours rapidly



**Direct Spray Control:** FinishControl is particularly easy to use. (1) The continuously adjustable air volume and the (2) material volume control ensure a precisely tailored approach to the material. (3) The spraying level and spray pattern width can be adjusted to suit the item being coated

**High-performance turbine with a light weight:** Start the turbine easily on the gun by pressing the trigger into the first level. Depress the trigger completely to start the material flow

TECHNICAL DATA	FINISHCONTROL 3500
Voltage	230 V / 50 Hz
Motor output	700 W
Operating pressure, max.	0.2 bar, 0.02 MPa
Weight	3.5 kg
Scope of delivery	Turbine housing with handle; Spray attachment StandardSpray; Carrying case; Air filter (3 pcs.); Carrying strap with strap holder; Cleaning brush
Art. No.	2341501



# FINISHCONTROL 5500 SPRAYPACK

Perfect finishes made easy

- **Click&Paint system:** for fast spray attachment changes and simple cleaning
- **DirectSprayControl:** precise and easy handling due to adjustable material and air volume, as well as adjustment of the paint jet directly on the gun
- **Highly efficient turbine:** with optimum atomisation performance
- **Easy maintenance:** easily accessible double filters with warning light indicating that the air filters need to be changed
- **Fast cleaning:** spray attachment with minimal number of components

**Click & Paint System:** detachable gun for fast spray attachment changes and simple cleaning

**Direct Spray Control:** precise and easy handling due to adjustable material and air volume, as well as the spray pattern, directly on the gun

**Filter warning light:** indicates when the filter needs cleaning or replaced

**Integrated storage box:** ideal for needles, air caps, tools and cleaning accessories

**Cup holder:** ideal for storage and transport of 1000 ml XVLP cups



**XVLP gun & cup:** improved ergonomical design, haptic and atomization

**Spray attachment StandardSpray:** pleasant to work with due to low spray mist and compact, extra-light design. The minimal number of components ensures easy cleaning and maintenance

**Twin air filters:** easily accessible filters with large surface for optimal atomisation

TECHNICAL DATA	FINISHCONTROL 5500
Voltage	230 V / 50 Hz
Motor output	1.15 kW
Operating pressure, max.	0.29 bar, 0.029 MPa
Weight	6.6 kg
Scope of delivery	Base unit FinishControl 5500; Air hose incl. handle, 5 m; XVLP Spray attachment StandardSpray; Cleaning kit
Art. No.	2422986



# FINECOAT 9700 SPRAYPACK

The specialist for lacquer

- **HVLP Ultra gun:** ergonomic design for fatigue-free spraying
- **Exact adjustment possibilities to the object and an unmistakably fine spray pattern:** even with water dilutable materials
- **Twin air filters:** easily accessible filters with large surface for optimal atomisation
- **Integrated storage box:** ideal for needles, air caps, tools and cleaning accessories

**HVLP Ultra Gun:** improved ergonomics and fine atomisation

**Precise adjustment of the spray pattern:** the spray jet can be perfectly adjusted to the object to be coated

**Gun holder:** for HVLP guns with gravity feed cup (gun with gravity feed cup available as separate accessory)

**Integrated storage box:** ideal for needles, air caps, tools and cleaning accessories



**Filter warning light:** indicates when the filter needs cleaning or replaced

**Twin air filters:** easily accessible filters with large surface for optimal atomisation

**Cup holder:** for storage and transport of the HVLP gun with cup

TECHNICAL DATA	FINECOAT 9700
Voltage	230 V / 50 Hz
Motor output	1.15 kW
Operating pressure, max.	0.3 bar, 0.03 MPa
Weight	6.8 kg
Scope of delivery	Base unit FineCoat 9700; HVLP air hose, 7.6 m; HVLP FineCoat Gun Ultra; Cleaning kit
Art. No.	2426601



# FINECOAT 9900 PLUS SPRAYPACK

High-performance HVLP paint specialist in a handy design

- **Compact and easy to use**
- **Permits precise adaptation to the object to be painted and provides an unmistakably fine spray pattern:** even with water-based materials
- **Wide range of applications:** both interiors and exteriors
- **Not suitable for:** use in potentially explosive atmospheres

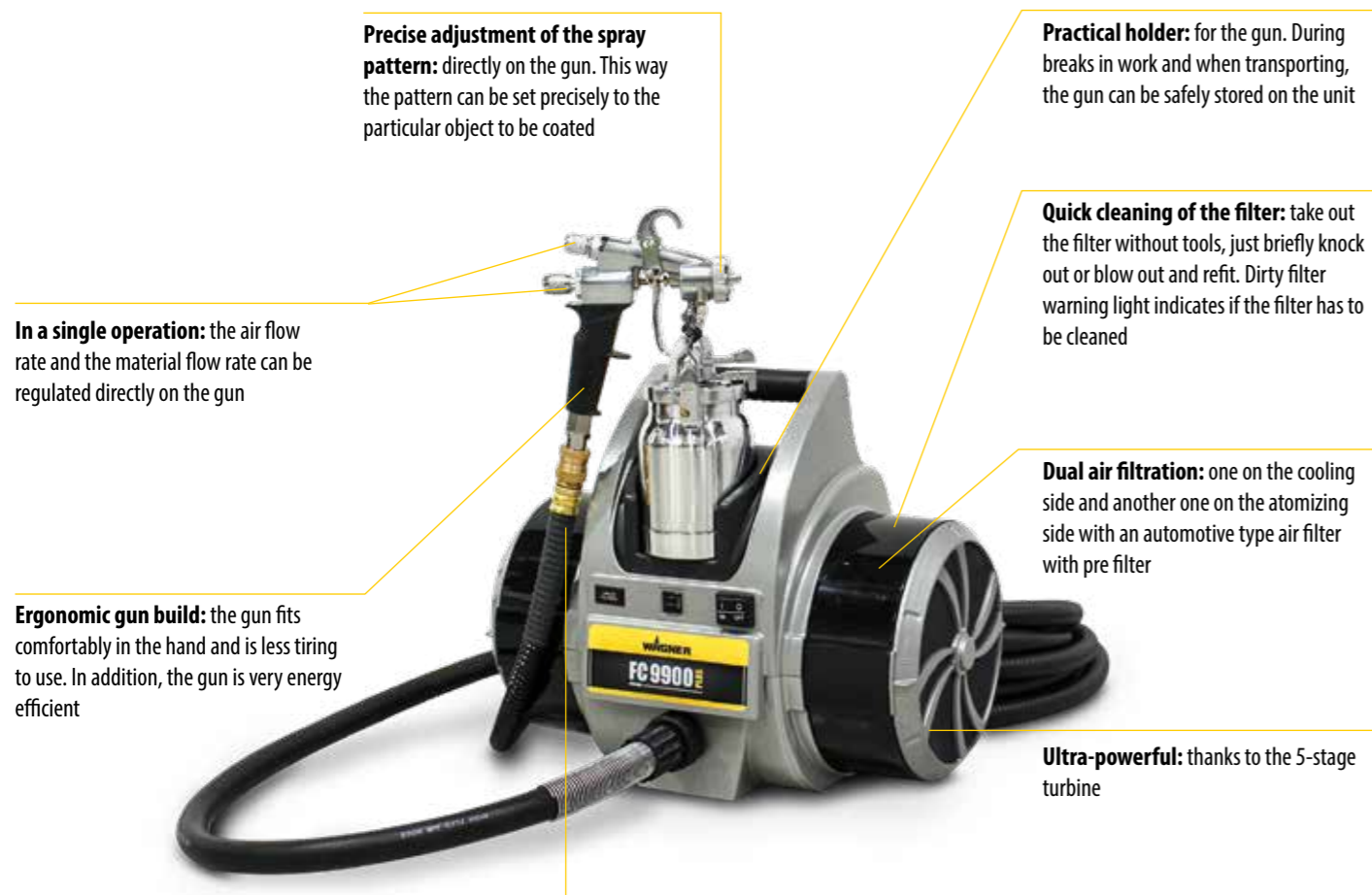

**Precise adjustment of the spray pattern:** directly on the gun. This way the pattern can be set precisely to the particular object to be coated

**Practical holder:** for the gun. During breaks in work and when transporting, the gun can be safely stored on the unit

**Quick cleaning of the filter:** take out the filter without tools, just briefly knock out or blow out and refit. Dirty filter warning light indicates if the filter has to be cleaned

**Dual air filtration:** one on the cooling side and another one on the atomizing side with an automotive type air filter with pre filter

**In a single operation:** the air flow rate and the material flow rate can be regulated directly on the gun

**Ergonomic gun build:** the gun fits comfortably in the hand and is less tiring to use. In addition, the gun is very energy efficient

**Ultra-powerful:** thanks to the 5-stage turbine

**Quick-release coupling with integral swivel joint:** for quick connection of the gun to the air hose

TECHNICAL DATA	FINECOAT 9900 PLUS
Voltage	230 V / 50 Hz
Motor output	1.5 kW
Operating pressure, max.	0.72 bar, 0.072 MPa
Weight	15 kg
Scope of delivery	Base unit FineCoat 9900; Air hose; FineCoat gun, 1 litre pressure cup, incl. nozzle set No. 4
Art. No.	276048



## PRACTICAL ACCESSORIES FOR XVLP AND HVLP TURBINES

HVLP GUNS	Art. No.
FineCoat Split Gun, gravity feed cup, 600 ml	524053
FineCoat Split Gun, suction cup, 1000 ml	524028
FineCoat Gun, pressure cup 1 litre, incl. nozzle kit no. 4	279094
Conversion kit FC Split Gun to flow cup, 1000 ml	524045
Ultra Gun HVLP gun	2435747
WSL 50 Spraying Lance: Areas of application - Renovation and repair, ceiling and wall design; Material supply via commercially available pressure tank	0261023
Pressure tank, for HVLP guns, 2 litres	524232



**HVLP Split Gun – 600 ml flow cup – for wood & metal paints**

XVLP FINISHCONTROL SPRAY ATTACHMENT	Art. No.
FineSpray, for low-viscosity materials and glazes	2430385
StandardSpray, for all standard enamels	2430386
WallSpray, for emulsion and latex paints	2430387
Cup, 1400 ml	2324749
Cup, 1000 ml	2434525
Can Adapter, for adapting original containers to the spray attachments	2350692



**FineSpray spray attachment XVLP – for wood & metal paints**

XVLP OTHER	Art. No.
Air filter, for FC 5500, 4 pieces	2434505
Air filter, for FC 3500, 3 pieces	2343947
Feed tube filter fine, red, 5 pieces	2324248
Feed tube filter coarse, white, 5 pieces	2324249
Cleaning brush set	2430409

FINECOAT HOSES	Art. No.
Air hose complete, 9 m, for FC 9900 Plus	277236
Air hose complete, 7.6 m, for FC 9700	2424102
Hose assembly, DN10, 8.2m, for FineCoat	261255
Hosw whip, 152 cm, for FineCoat	0524405A

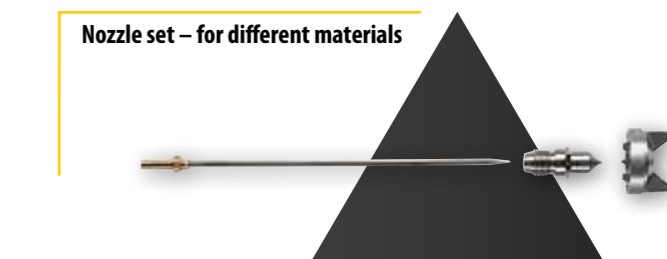

**Nozzle set – for different materials**

HVLP NOZZLE SETS FOR FINECOAT GUN	Art. No.
Nozzle set, No. 2, Ø 0.8 mm	276254
Nozzle set, No. 3, Ø 1.3 mm	276227
Nozzle set, No. 4, Ø 1.8 mm	276228
Nozzle set, No. 5, Ø 2.2 mm	276229
Nozzle set, No. 6, Ø 2.5 mm	276245
Nozzle set, No. 7, Ø 2.7 mm	524211

HVLP NOZZLE SETS FOR FINECOAT SPLIT GUN	Art. No.
Nozzle set, No. 2, Ø 0.5 mm	529209
Nozzle set, No. 3, Ø 1.3 mm	529210
Nozzle set, No. 4, Ø 1.8 mm	529211
Nozzle set, No. 5, Ø 2.2 mm	529212
Nozzle set, No. 6, Ø 2.4 mm	529213

HVLP NOZZLE SETS FOR ULTRA GUN	Art. No.
Nozzle set, No. 2, Ø 0.8 mm	2434549
Nozzle set, No. 3, Ø 1.3 mm	2434550
Nozzle set, No. 4, Ø 1.8 mm	2434551
Nozzle set, No. 5, Ø 2.2 mm	2434552
Nozzle set, No. 6, Ø 2.5 mm	2434553
Nozzle set, No. 7, Ø 2.7 mm	2434554

## HEA – HIGH EFFICIENCY AIRLESS

Up to 55% less overspray with maximum control

Do you already value the advantages of airless technology, such as control and comfort? Then you'll be inspired by the new HEA ProTip airless nozzle from WAGNER. It achieves perfect surface results at a much lower spray pressure. Compared to conventional airless technology, you achieve a streak free coverage with softer spray edges.



### More efficiency for prolonged working:

Thanks to the HEA nozzle technology, the spray pressure can be significantly lowered. This reduces the overspray by up to 55 percent\*. Apart from reducing the amount of masking needed, this also has a positive effect on the gun's recoil. Working with a WAGNER airless pump is made even easier and more convenient with the HEA technology.

### Robust and durable:

The nozzle wears more slowly due to the lower spray pressure. This means that HEA nozzles can be used for considerably longer than conventional airless nozzles. Loads on the pump are also reduced due to the lower pressure, with handling of the gun also improved.

### 1. MAXIMUM CONTROL:

The gentle spray pattern ensures a more even surface when overlapping the paths and avoids hard edges. This leads to a simple and easy-to-learn technique – even for inexperienced users.

### 2. PERFECT SURFACE QUALITY:

High Efficiency Airless ensures a uniform and even application on all surfaces and therefore offers excellent surface quality – especially when compared to conventional applications with a brush and roller.

### 3. INCREASED EQUIPMENT LIFESPAN:

Even the lifespan of the spray device itself is prolonged: the lower spraying pressure with High Efficiency Airless means that the system and its components are under less strain.

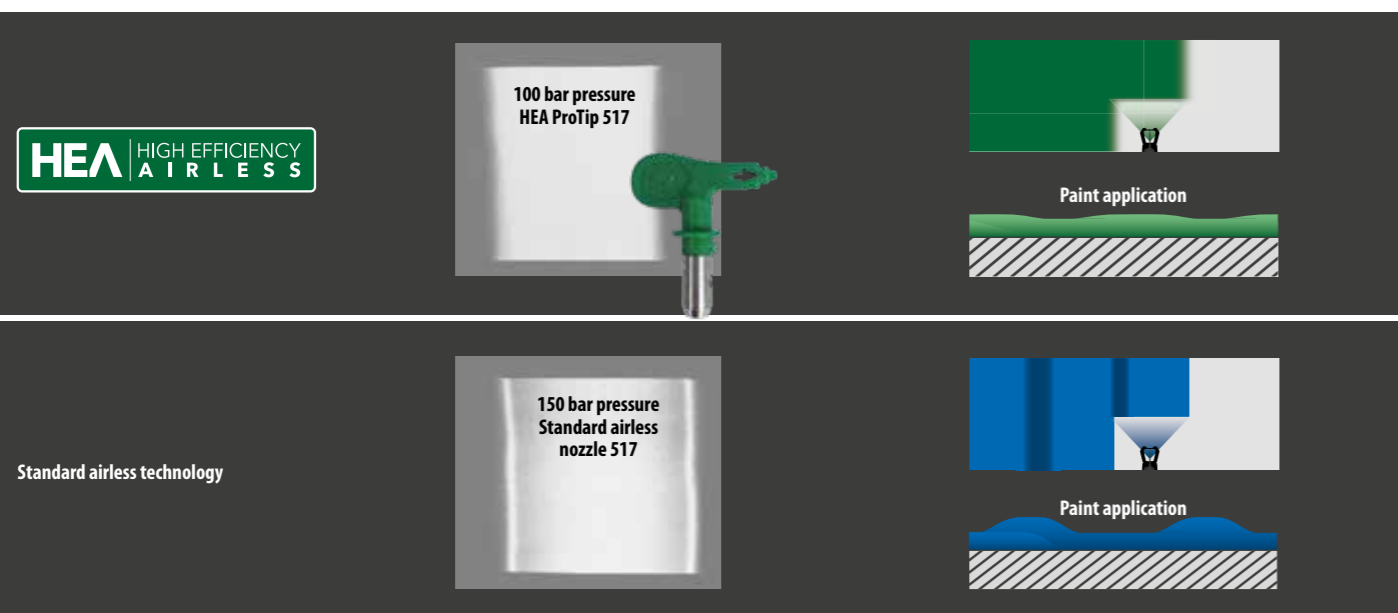

\*compared to other airless nozzles on the market

## DIAPHRAGM PUMP

Effective material intake – broad range of materials

Do you want to process different materials, from primers to silicate paints with just one device? Then a WAGNER diaphragm pump is the ideal choice. This powerful, maintenance friendly technology transports the material via a lifting motion of the diaphragm. Diaphragm pumps from WAGNER are robust, easy-to-use construction site and workshop units.

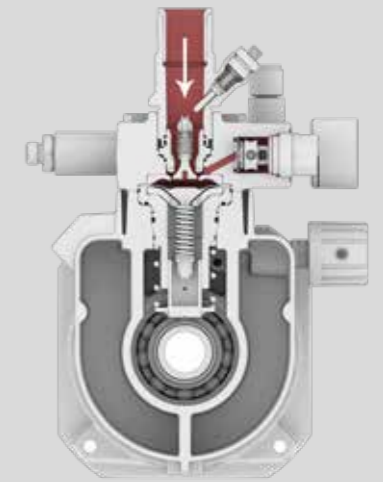

### The perfect companion for painters and affiliated trades:

The patented Quality-Long-Stroke (QLS) technology from WAGNER, with its optimised hydraulics and special valve technology, means that the material is taken in much more effectively compared to diaphragm pumps from other manufacturers. As a result, a broad range of different materials, such as primers and release agents, primers and lacquers, emulsion and silicate paints, fabric adhesives, corrosion and flame retardants can be processed. In the domain of specially filled materials such as bitumen, fire protection and fillers, piston and spiral pumps are the specialists. Electrically operated diaphragm pumps can be used in both Airless and AirCoat processes with additional air atomization.

### Fire retardants for joiners, metalworkers and similar trades:

Pneumatic double diaphragm pumps are ideal for the wood and metal processing industry. In this case, the material is transported via the lifting motion of two opposing diaphragm which generates a lower-pulsation material flow. This allows you to work with materials which are particularly sensitive to shearing and moisture and with premixed two-component materials. WAGNER double diaphragm pumps are explosion-proof and operated by compressed air, which means that they can be used safely in workshops and in painting booths.

### 1. ALSO SUITABLE FOR VERY SMALL VOLUMES:

Diaphragm pumps have up to 58 %\* less material in their system. The device's small cross-sections means that it can also be operated with tiny amounts of material. This saves resources both when changing material and during the cleaning process.

### 2. LOW-MAINTENANCE AND DURABLE:

The reduced lifting frequency of the diaphragm means that the already lower number of wear parts are placed under significantly less stress. This significantly reduces maintenance costs\*. However, should a repair be necessary, the corresponding components can be easily replaced directly on site and in the case of both valves for example, within minutes.

### 3. FINE AND EVEN SPRAY PATTERN:

Diaphragm technology reduces the pulsation of the material flow, which avoids any irregularities in the spray pattern, remaining uniform and even.

## SPRAYPATTERN AT LOW PRESSURE



\*compared to other piston pumps on the market

## BENEFITS

- Large range of material
- Flexible material intake(also small quantities)
- Fully adjustable pressure regulation from 0 - 25 MPa
- QLS technology with longer stroke
- Very fine, even spray pattern
- Robust and very low-maintenance
- Simple maintenance
- Low noise

# SUPERFINISH 23 PRO HEA SPRAYPACK

For perfect results with maximum control thanks to innovative airless diaphragm technology

- **Innovative HEA technology:** up to 55 % less overspray with maximum control
- **Flexible suction hose:** the diaphragm pump draws materials such as emulsions, latex paints or lacquers directly from the original container
- **For medium-sized emulsion jobs**
- **Compact:** with height-adjustable telescopic handle for easy transport and space-saving storage
- **Quality LongStroke Technology (QLS):** for a long service life, easy maintenance and low wear

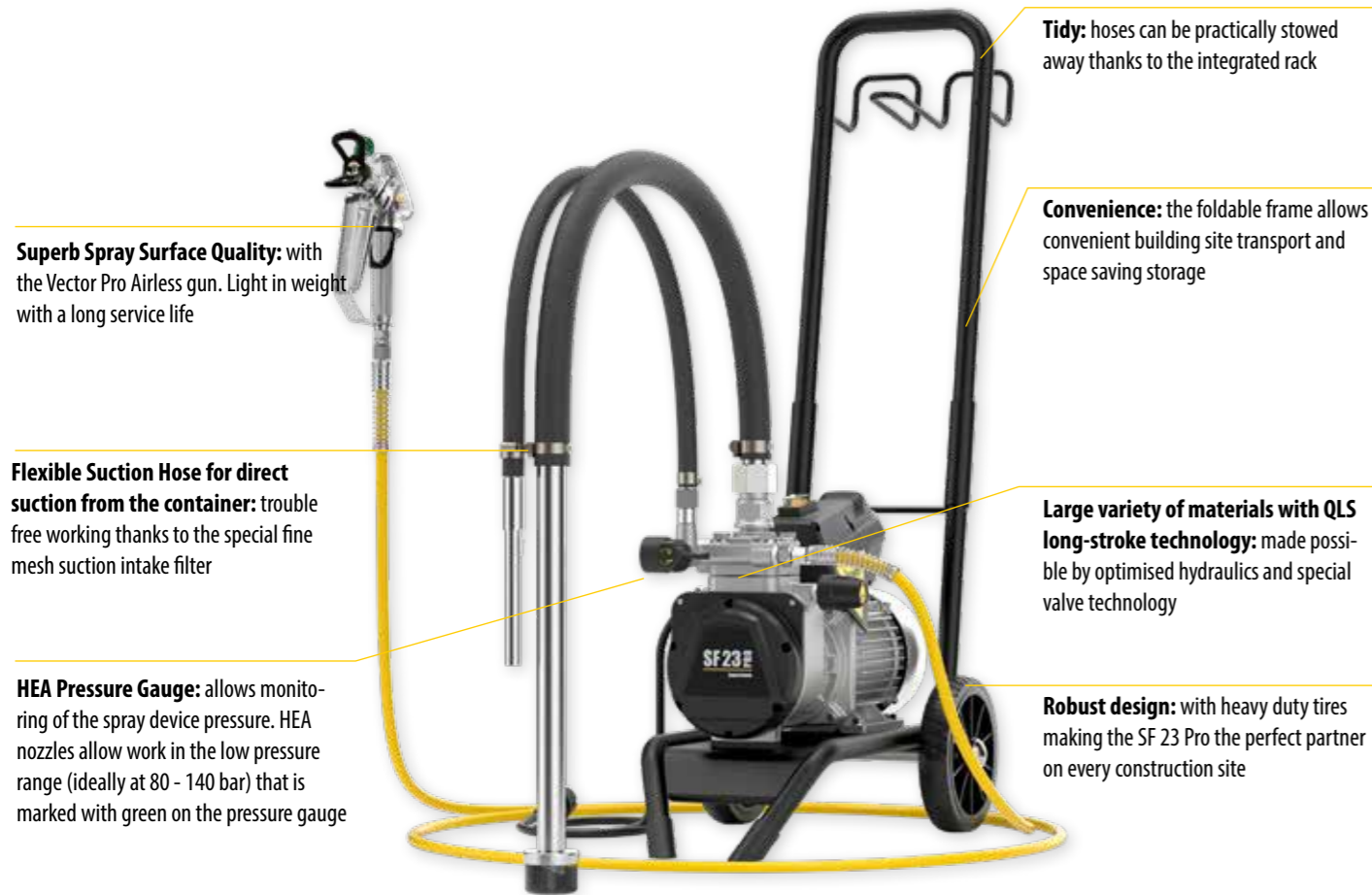

**Superb Spray Surface Quality:** with the Vector Pro Airless gun. Light in weight with a long service life

**Flexible Suction Hose for direct suction from the container:** trouble free working thanks to the special fine mesh suction intake filter

**HEA Pressure Gauge:** allows monitoring of the spray device pressure. HEA nozzles allow work in the low pressure range (ideally at 80 - 140 bar) that is marked with green on the pressure gauge

**Tidy:** hoses can be practically stowed away thanks to the integrated rack

**Convenience:** the foldable frame allows convenient building site transport and space saving storage

**Large variety of materials with QLS long-stroke technology:** made possible by optimised hydraulics and special valve technology

**Robust design:** with heavy duty tires making the SF 23 Pro the perfect partner on every construction site

TECHNICAL DATA	SUPERFINISH 23 PRO HEA
Voltage	230 V / 50 Hz
Motor output	1.3 kW
Operating pressure, max.	250 bar, 25 MPa
Delivery rate, max.	2.6 l/min
Nozzle size, max.	0.023"
Recommended hose length, max.	30 m
Viscosity, max.	20.000 mPas
Weight	27 kg
Scope of delivery	Base unit SF 23 Pro; HP hose DN6; Suction hose incl. return hose and filter; Airless gun Vector Pro; HEA ProTip 519; HEA pressure gauge set; Tool bag
Art. No.	2399198



# SUPERFINISH 23 PLUS HEA SPRAYPACK

Compact – light and yet robust

- **Innovative, low-pressure airless technology:** up to 55 % less overspray
- **Compact:** smallest in its class, mobile and light
- **For medium-sized emulsion jobs**
- **Robust:** ideal for demanding construction site use
- **PumpRunner:** perfect for clean, tidy transport



**Large variety of materials with QLS long-stroke technology:** the optimised hydraulics and special valve technology make it possible

**Multifunction switch for extra safety:** on/off as well as circulation and spray mode. This prevents accidental switching on or off while the system is under pressure



**Superb spray surface quality:** with the Vector Grip Airless gun. Light in weight with a long service life

**Infinitely variable pressure regulation:** from 0 to 250 bar

**Direct suction:** straight from the container for trouble-free working. Inclusive PumpRunner for clean transport included

TECHNICAL DATA	SUPERFINISH 23 PLUS HEA
Voltage	230 V / 50 Hz
Motor output	1.3 kW
Operating pressure, max.	250 bar, 25 MPa
Delivery rate, max.	2.6 l/min
Nozzle size, max.	0.023"
Recommended hose length, max.	30 m
Viscosity, max.	20.000 mPas
Weight	29 kg
Scope of delivery	Base unit SF 23 Plus; Suction system complete, incl. PumpRunner; HP hose DN6; Airless gun Vector Grip incl. TradeTip 3 nozzle holder; HEA ProTip 519; Gun filter white
Art. No.	2384153





# SUPERFINISH 23 PLUS AIRLESS ENAMEL SPRAYPACK

The perfect solution for small paint jobs using diaphragm technology

- **Entry-level Airless spraypack:** for painting objects
- **Str straightforward handling and simple operation:** multifunction switch for greater safety - It is impossible to turn the unit on and off under pressure
- **Improved performance:** no-maintenance brushless motor
- **FineFinish painting:** with hopper and the special FineFinish nozzle



TECHNICAL DATA	SUPERFINISH 23 PLUS AIRLESS ENAMEL
Voltage	230 V / 50 Hz
Motor output	1.3 kW
Operating pressure, max.	250 bar, 25 MPa
Delivery rate, max.	2.6 l/min
Nozzle size, max.	0.023"
Recommended hose length, max.	30 m
Viscosity, max.	20.000 mPas
Weight	29 kg
Scope of delivery	Base unit SF 23 Plus; 5 litre hopper; HP hose DN3; Airless gun Vector Grip incl. TradeTip 3 nozzle holder; TradeTip 3 FineFinish nozzle 410; Gun filter red
Art. No.	2341492



# SUPERFINISH 23 PLUS TEMPSPRAY SPRAYPACK

Enamel specialist with heated hose

- **Perfect surface results:** thanks to heated hose
- **Also ideal for:** highly viscous materials such as enamels with high VOC content
- **The TempSpray system heats the material directly in the hose:** thereby ensuring perfect viscosity without the need for thinning, as well as optimum paint application



TECHNICAL DATA	SUPERFINISH 23 PLUS TEMPSPRAY
Voltage	230 V / 50 Hz
Motor output	1.3 kW
Operating pressure, max.	250 bar, 25 MPa
Delivery rate, max.	2.6 l/min
Nozzle size, max.	0.023"
Recommended hose length, max.	10 m
Viscosity, max.	20.000 mPas
Weight	29 kg
Scope of delivery	Base unit SF 23 Plus; 5 litre hopper; TempSpray H 126 base unit; Airless gun Vector Grip incl. TradeTip 3 nozzle holder; TradeTip 3 FineFinish nozzle 410; Gun filter red
Art. No.	2341496



# SUPERFINISH 23 PLUS AIRCOAT ENAMEL SPRAYPACK

## Mobile complete solution for enamel work

- **With AirCoat technology:** particularly fine atomisation for a perfect finish
- **Perfectly matching components:** minimal overspray and high application efficiency
- **Particularly easy handling**
- **The industry standard:** quality-crafted by WAGNER
- **Suitable for:** non EX environments

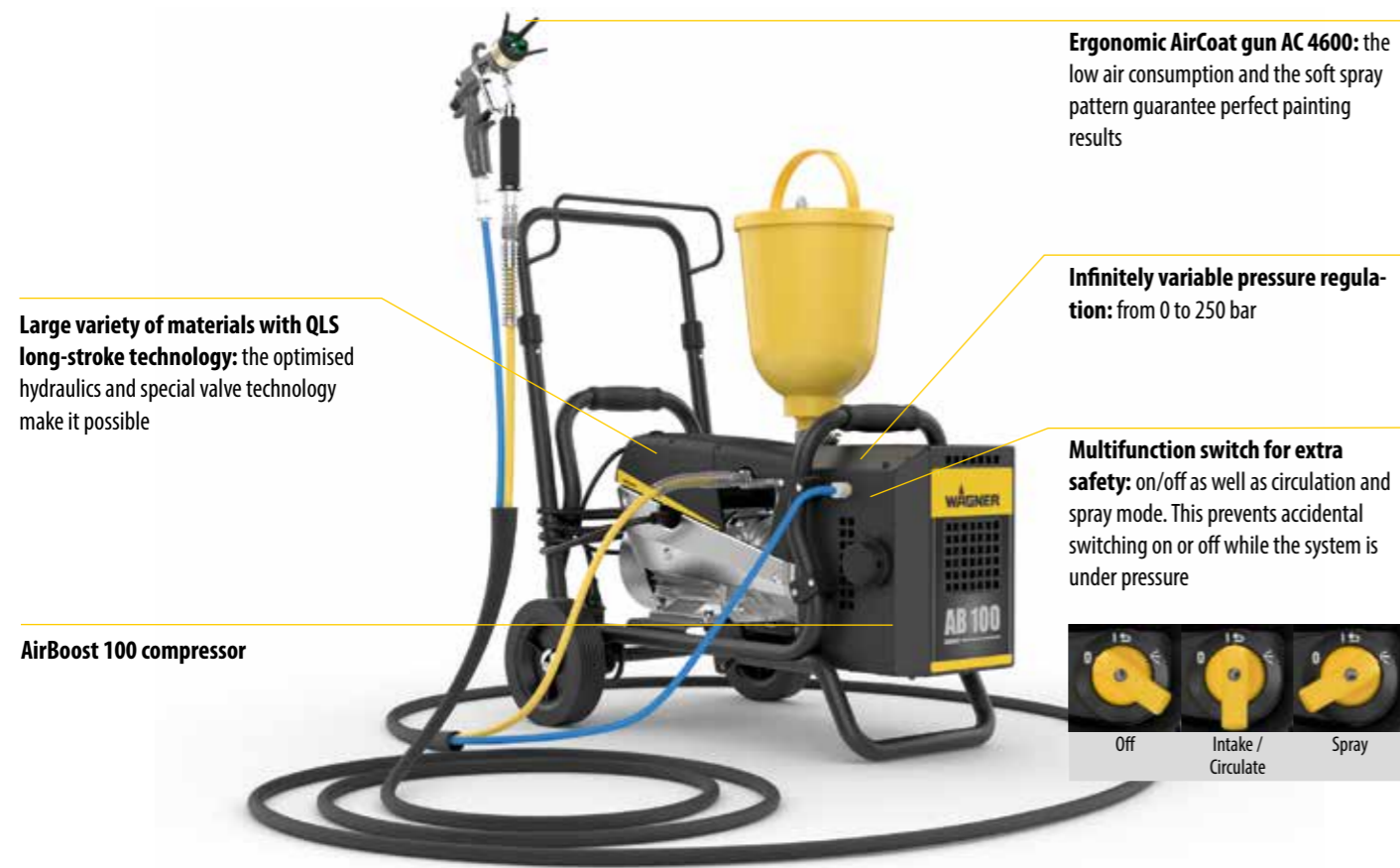

**Large variety of materials with QLS long-stroke technology:** the optimised hydraulics and special valve technology make it possible

**AirBoost 100 compressor**

**Ergonomic AirCoat gun AC 4600:** the low air consumption and the soft spray pattern guarantee perfect painting results

**Infinitely variable pressure regulation:** from 0 to 250 bar

**Multifunction switch for extra safety:** on/off as well as circulation and spray mode. This prevents accidental switching on or off while the system is under pressure



TECHNICAL DATA	SUPERFINISH 23 PLUS AIRCOAT ENAMEL
Voltage	230 V / 50 Hz
Motor output	1.3 kW
Operating pressure, max.	250 bar, 25 MPa
Delivery rate, max.	2.6 l/min
Nozzle size, max.	0.023"
Recommended hose length, max.	7.5 m
Viscosity, max.	20.000 mPas
Weight	29 kg
Scope of delivery	Base unit SF 23 Plus; 5 litre hopper; HP double hose; AirCoat gun AC 4600; Nozzle ACF3000; Air cap green; AirBoost 100 compressor; AirCoat regulator, fitting kit
Art. No.	2353393



# SUPERFINISH 23 CR

## Professional injection and crack repair

- **Powerful:** big diaphragm surface for perfect usage with high viscosity materials and a long life time
- **Variety of materials:** suitable for Epoxy and Polyurethanes (PU), SPUR foam, aqueous solutions
- **Simple:** service, cleaning and maintenance directly on the job site is no problem at all
- **Ease of use:** handy pressure regulation in low pressure areas
- **Durable:** all wetted parts out of stainless steel

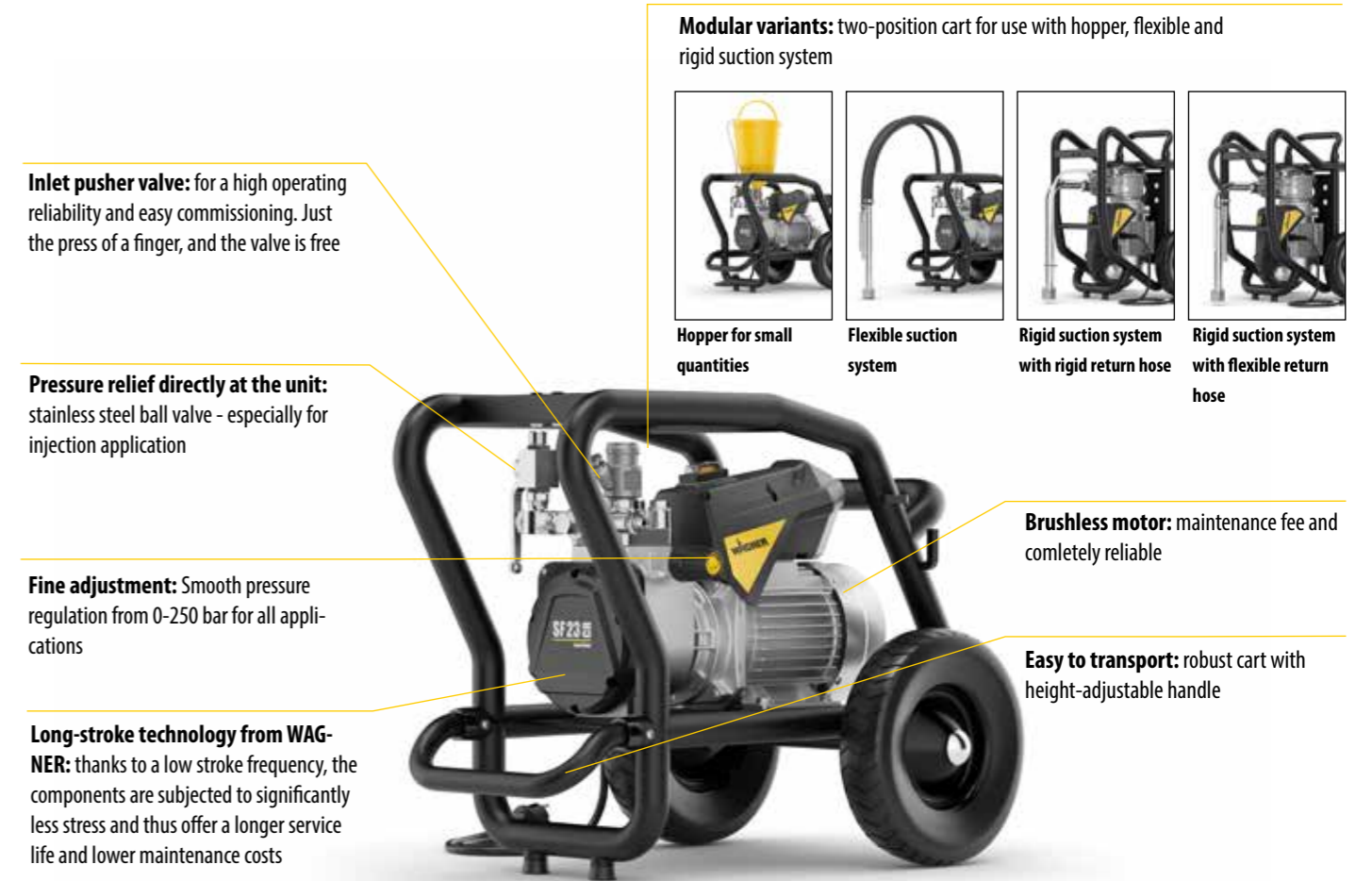

**Inlet pusher valve:** for a high operating reliability and easy commissioning. Just the press of a finger, and the valve is free

**Pressure relief directly at the unit:** stainless steel ball valve - especially for injection application

**Fine adjustment:** Smooth pressure regulation from 0-250 bar for all applications

**Long-stroke technology from WAGNER:** thanks to a low stroke frequency, the components are subjected to significantly less stress and thus offer a longer service life and lower maintenance costs

**Modular variants:** two-position cart for use with hopper, flexible and rigid suction system



Hopper for small quantities

Flexible suction system

Rigid suction system with rigid return hose

Rigid suction system with flexible return hose

**Brushless motor:** maintenance free and completely reliable

**Easy to transport:** robust cart with height-adjustable handle

TECHNICAL DATA	SUPERFINISH 23 CR
Voltage	230 V / 50 Hz
Motor output	1.3 kW
Operating pressure, max.	250 bar, 25 MPa
Delivery rate, max.	2.6 l/min
Nozzle size, max.	-
Recommended hose length, max.	15 m
Viscosity, max.	20.000 mPas
Weight	29 kg
Scope of delivery	Base unit SF 23 CR on cart; Pressure gauge set HEA (MPa)
Art. No.	2415601

ACCESSORIES FOR INJECTION WORK	Art. No.
Hose whip with mouthpiece	2434357
Hopper 5 litre, M36x2	2357506
Suction system, flexible	2393123
Suction system, rigid, with flexible return hose	2405950
Suction system, rigid, with rigid return hose	2429697
Airless gun AG 14, G-thread 1/4", incl. TradeTip 3 nozzle holder	0502081A



# SUPERFINISH 33 PRO SPRAYPACK

One diaphragm pump for every project – outstanding performance for in- and outdoor application

- **Versatile applications:** the SuperFinish 33 Pro can process a diverse range of materials and service a wide variety of industries and project sizes
- **Quality LongStroke Technology (QLS):** for a long service life, easy maintenance and low wear
- **Optimum efficiency and productivity:** with a delivery rate of 4.3 litres per minute, the SuperFinish 33 Pro is the most powerful WAGNER diaphragm pump in the professional segment
- **Practical multi-gun operation:** for parallel use, a distributor adapter for connecting up to three airless guns is available separately as an accessory



TECHNICAL DATA	SUPERFINISH 33 PRO
Voltage	230 V / 50 Hz
Motor output	2.2 kW
Operating pressure, max.	250 bar, 25 MPa
Delivery rate, max.	4.3 l/min
Nozzle size, max.	0.033"
Recommended hose length, max.	60 m
Viscosity, max.	25.000 mPas
Weight	43 kg
Scope of delivery	Base unit SF 33 Pro; Suction system, flexible; Hp hose DN6; Airless gun Vector Pro incl. TradeTip3 nozzle holder; HEA ProTip nozzle 521
Art. No.	2388260



# SUPERFINISH 33 PLUS SPRAYPACK

The extremely easy-to-use diaphragm pump for every project

- **Versatile applications:** the SuperFinish 33 Plus can process a diverse range of materials and service a wide variety of industries and project sizes
- **Optimum efficiency and productivity:** with a delivery rate of 4.3 litres per minute, the SuperFinish 33 Plus is the most powerful WAGNER diaphragm pump in the professional segment
- **Practical multi-gun operation:** for parallel use, a distributor adapter for connecting up to three airless guns is available separately as an accessory
- **Flexible use:** switch the pump position with a single hand movement from working with the top container to the rigid suction system with fine filter meshes



TECHNICAL DATA	SUPERFINISH 33 PLUS
Voltage	230 V / 50 Hz
Motor output	2,2 kW
Operating pressure, max.	250 bar, 25 MPa
Delivery rate, max.	4,3 l/min
Nozzle size, max.	0,033"
Recommended hose length, max.	60 m
Viscosity, max.	25.000 mPas
Weight	50 kg
Scope of delivery	Base unit SF 33 Plus; Suction system, rigid; HP hose DN6; Airless gun Vector Grip incl. TradeTip3 nozzle holder; HEA ProTip nozzle 521
Art. No.	2388259



## PRACTICAL ACCESSORIES FOR ELECTRIC DIAPHRAGM PUMPS

### ENAMEL KIT (DN4) FOR ALL SUPERFINISH PUMPS

Suitable for SF 23 Plus, SF 33, SF 27, SF 31.

- HP hose DN4, NPSM 1/4", max 27 MPa / 270 bar, 7.5 m
- Vector Pro gun
- Nozzle extension, G-thread, 15 cm
- FineFinish TT3 nozzle 308 (Lack)
- FineFinish TT3 nozzle 412 (Füller)
- TipClean 200 ml
- Gun filter, red, extra fine, 10 pieces
- Hopper 5 litre, M36 x 2

SPRAYKIT	Art. No.
Enamel Kit (DN4)	2406207



### 2GUN KIT – CONNECTION OF UP TO THREE GUNS ON ONE DEVICE

Suitable for: all Heavy Coat pumps, SF33 as well as PS 3.31 upwards.

- Adapter for multi-gun operation (for max. 3 guns)
- Vector Grip gun
- HP hose DN6, NPSM 1/4", 15 m, max. 27 MPa / 270 bar, 15 m
- Double connector NPSM 1/4"

SPRAYKIT	Art. No.
2Gun Kit	2413598



### HEA KIT (DN6) FOR ALL PUMPS WITH 1/4" CONNECTORS

Suitable for all SuperFinish and ProSpray pumps, as well as PowerPainter 90

- HP hose DN6; NPSM 1/4"; max. 27 MPa / 270 bar; 15 m
- Vector Pro gun
- Nozzle extension, G-thread, 15 cm
- HEA ProTip nozzle 517
- HEA ProTip nozzle 311
- TipClean 200 ml
- Gun filter, white, medium, 10 pieces

SPRAYKIT	Art. No.
HEA Kit (DN6)	2408212



AIRCOAT ACCESSORIES	Art. No.
AirCoat gun AC 4500, incl. blue air cap and holder	2368269
AirCoat nozzles ACF 3000; different sizes	379xxx
HP double hose, material DN3, max. 27 MPa, air DN6, 1/4", 7.5 m	9984595
Air cap blue, incl. union nut	394911
Air cap green, incl. union nut	394912
Air cap red, incl. union nut	394910
Union nut, complete	394921
Compressor AirBoost 100	2347935
AirCoat regulator, fitting kit	340250

HOPPER	Art. No.
Hopper 20 litre, M36x2, for SuperFinish	341266
Hopper 5 litre, M36x2, for SuperFinish	341265
Hopper 5 litre, with TopClean, for SuperFinish	341268

## NOTES

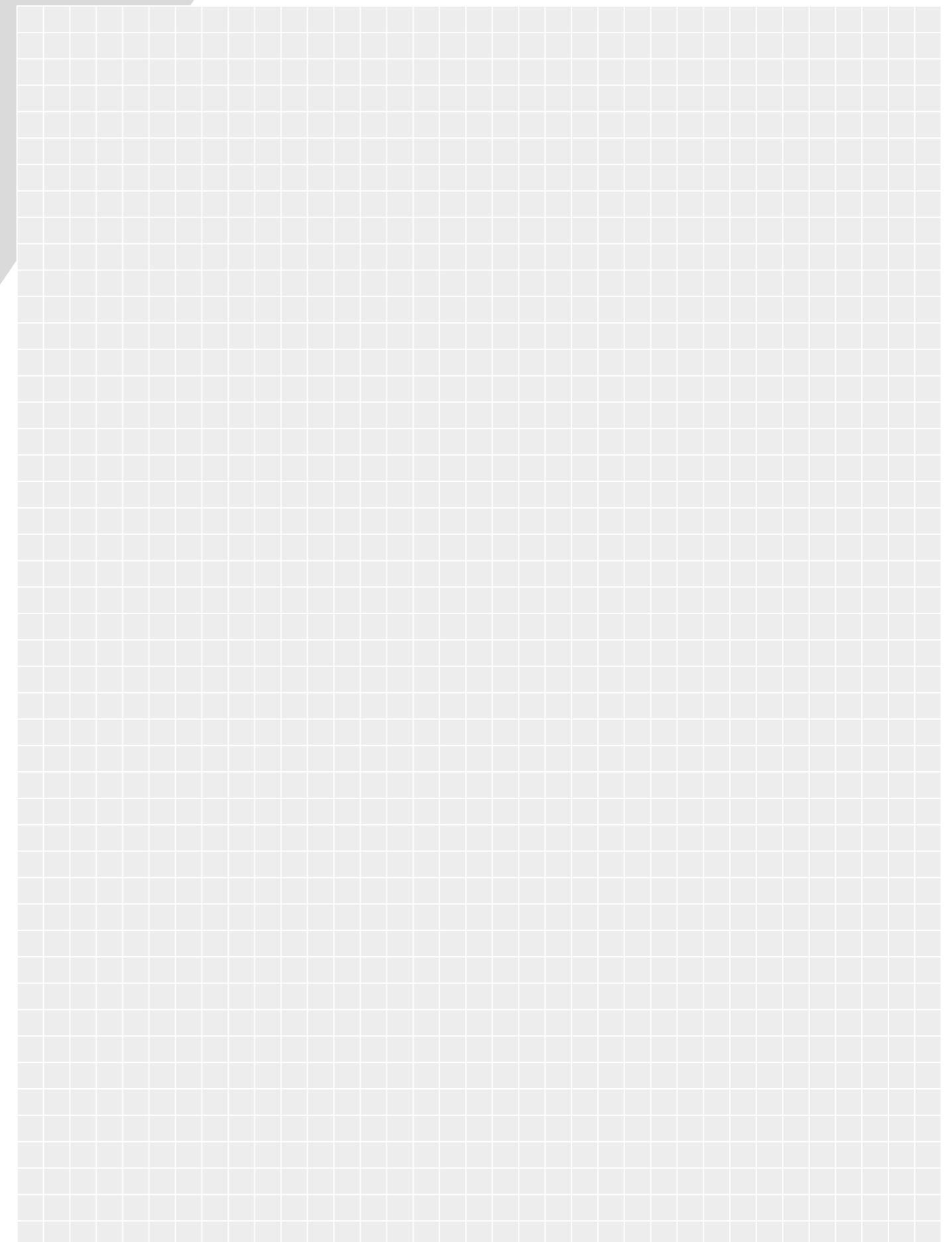

## ELECTRIC PISTON PUMPS

Especially high suction and delivery performance – across the range

Do you mostly work with viscose or filler materials? Then an electric WAGNER piston pump is the best support for you. The high suction power produced by the piston's lifting motion makes it ideal for this type of material.

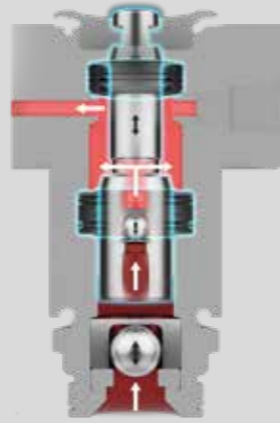

### Various performance classes for professional and semi-professional users:

With the third generation of piston pumps from WAGNER, you have a choice of machines for large or small sites. They cover a broad range of paints and emulsions - right through to high-viscosity and filler materials for interior and exterior use.

### A powerful companion - inside and out:

WAGNER piston pumps are available with three different drive systems. Electric piston pumps cover a wide range of performance classes and have a compact design. The hydraulic piston pumps offer even better performance and are available with a choice of either a petrol or an electric motor which can be switched in a few minutes. Pneumatically driven piston pumps from WAGNER are explosion-proof and therefore are suitable for use in workshops.

### 1. BRUSHLESS MOTOR:

Brushless motors are a real benefit for this device, especially in terms of its long service life. Alongside its efficient mode of working, its key advantages include a constantly high torque with low power consumption and reduced heat generation.

### 2. NO CONTINUOUS RUNNING:

Piston pumps only operate when you have to build up pressure. The rest of the time, the drive is on 'standby'. This protects wear parts and has a positive impact on site noise levels.

## CROSS-SECTION OF THE PISTON

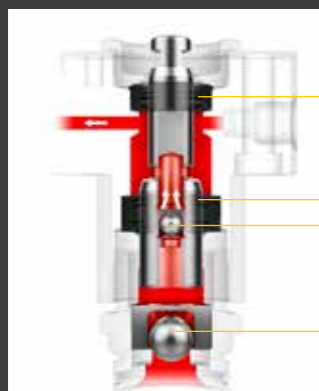

Upper packing

Lower packing  
Outlet valve

Inlet valve

## ADVANTAGES

- Powerful suction
- Better delivery capacity with high viscosity materials
- Less sensitive to filled materials
- Large nozzle sizes can be used
- Extra-durable packing

# POWERPAINTER 90 EXTRA SPRAYPACK

Fast, clean, perfect – the airless paint spraying system for small projects

- **Innovative, high-efficiency airless technology (HEA):** the HEA ProTip nozzle ensures up to 55 % less overspray, as well as a longer service life thanks to reduced spray pressure
- **Easy painting:** noticeably easier paint application thanks to a soft spraying pattern with maximum control
- **Direct suction from the original container:** the airless paint spraying system extracts materials directly out of the paint bucket or varnish container

**Comfortable:** the adjustable telescopic handle allows convenient transport on the construction site as well as spacesaving storage

**Pressure gauge:** allows the perfect control of pressure in coordination with the material being processed

**DN6, 15 m high-pressure hose:** for a large radius of action

**Integrated storage box:** ideal for storing tools and accessories

**Innovative HEA nozzle technology:** two nozzle orifices, one directly in front of the other, guarantee a perfect spray pattern with high material throughput even in low pressure ranges

**Lightweight airless gun with four-finger trigger:** for fatigue-free and safe work

**Double-Acting-piston pump:** for consistent material feed

**Inlet pusher valve:** for a high operating reliability and easy commissioning. Just the press of a finger, and the valve is free

Also available as skid-version



TECHNICAL DATA	POWERPAINTER 90 EXTRA SKID	POWERPAINTER 90 EXTRA CART
Voltage	230 V / 50 Hz	230 V / 50 Hz
Motor output	0.8 kW	0.8 kW
Operating pressure, max.	200 bar, 20 MPa	200 bar, 20 MPa
Delivery rate, max.	1.9 l/min	1.9 l/min
Nozzle size, max.	0.019"	0.019"
Recommended hose length, max.	15 m	15 m
Weight	10.2 kg	25.2 kg
Scope of delivery	Base unit PowerPainter 90 Extra; Airless gun Vector Pro incl. TradeTip3 nozzle holder; HP hose DN6; HEA pressure gauge; HEA ProTip nozzle 517; EasyGlide special oil	Base unit PowerPainter 90 Extra; Airless gun Vector Pro incl. TradeTip3 nozzle holder; HP hose DN6; HEA pressure gauge; HEA ProTip nozzle 517; EasyGlide special oil
Art. No.	2414079	2401275

# PROSPRAY 3.20 HEA SPRAYPACK

The compatible piston pump for airless beginners

- **Robust and simple:** perfect for use on the construction locations, reliable, easily accessible high quality packings
- **Good performance at an attractive price:** for medium-sized projects, ideal for interior emulsion paints
- **Innovative, low-pressure airless technology:** up to 55 % less overspray due to HEA technology
- **With flexible suction system:** for simple intake directly from the original container
- **Well-proven piston pump:** ideal for comfortable transport and space-saving storage



TECHNICAL DATA	PROSPRAY 3.20 HEA
Voltage	230 V / 50 Hz
Motor output	1.3 kW
Operating pressure, max.	207 bar, 20.7 MPa
Delivery rate, max.	2 l/min
Nozzle size, max.	0.021"
Recommended hose length, max.	30 m
Viscosity, max.	20.000 mPas
Weight	13.6 kg
Scope of delivery	Base unit ProSpray 3.20; HP hose DN6; Flexible suction system; Pressure gauge set HEA; Airless gun Vector Pro incl. TradeTip 3 nozzle holder; HEA ProTip nozzle 517
Art. No.	2412438



# PROSPRAY 3.21 HEA SPRAYPACK

Small and compact – for small object sizes

- **Innovative, low-pressure airless technology:** up to 55 % less overspray
- **Optimum value-for-money:** ideal for all users who mostly spray-coat small surfaces on a daily basis
- **For trouble-free operation:** integrated high-pressure filter
- **Compact design with outstanding performance**
- **data:** 0.023" nozzle size, 2.0 l/min max., delivery rate: 16 kg weight
- **With flexible suction system:** for simple intake directly from the original container



TECHNICAL DATA	PROSPRAY 3.21 HEA
Voltage	230 V / 50 Hz
Motor output	1.035 kW
Operating pressure, max.	221 bar, 22.1 MPa
Delivery rate, max.	2 l/min
Nozzle size, max.	0.023"
Recommended hose length, max.	30 m
Viscosity, max.	20.000 mPas
Weight	17.9 kg
Scope of delivery	Base unit ProSpray 3.21; HP hose DN6; Flexible suction system; Pressure gauge set HEA; Airless gun Vector Pro incl. TradeTip 3 nozzle holder; HEA ProTip nozzle 517
Art. No.	532089



# PROSPRAY 3.25 SPRAYPACK

A compact emulsion unit for medium-sized objects

- **Electronic control, information and management directly on the device:** displays the current pressure, pressure settings can be set and displayed, and much more.
- **Easy to handle:** compact design for ease of transport and space-saving storage
- **Lightweight:** just 27.4 kg
- **No-maintenance brushless motor**



**Clearly arranged - DESC-Control:** with the digital display you can read out and handle machine data, consumption figures, runtimes and much more. The intelligent deadband control, SlowMotion function and FrequentClean guarantee trouble-free work and quick cleaning

**Maintenance-free, brushless direct current motor:** due to the improved performance, the motor works even more efficiently at low and also at high speeds. The continuous paint pressure measurement controls the motor speed automatically, thus ensuring a constant material pressure

**HEA nozzle:** for a soft spray pattern and up to 55 % less overspray

**Superb spray surface quality:** with the Vector Grip Airless gun. Light in weight with a long service life

**Maintenance made easy:** with the push of a button the piston is oiled and thus the packings are conserved

**Inlet pusher valve:** for a high operating reliability and easy commissioning. Just the press of a finger, and the valve is free

TECHNICAL DATA	PROSPRAY 3.25
Voltage	230 V / 50 Hz
Motor output	1.1 kW
Operating pressure, max.	221 bar, 22.1 MPa
Delivery rate, max.	2.6 l/min
Nozzle size, max.	0.027"
Recommended hose length, max.	30 m
Viscosity, max.	25.000 mPas
Weight	27.4 kg
Scope of delivery	Base unit ProSpray 3.25; HP hose DN6; Airless gun Vector Grip incl. TradeTip 3 nozzle holder; HEA ProTip nozzle 519
Art. No.	2308260



# PROSPRAY 3.31 SPRAYPACK

A reliable unit for large-area emulsion work

- **Electronic control, information and management directly on the device:** displays the current pressure, pressure settings can be set and displayed, and much more.
- **No-maintenance brushless motor**
- **High coverage performance together with easy operation**
- **Innovative ProSpray product features:** digital information readout and unit control directly on the device - tilting carriage - integrated high-pressure filter - and more



**No nozzle blockages:** the high pressure filter is easily accessible and quick to clean. Three different filter inserts (fine, medium, coarse) ensure an optimal match with the material

**Superb spray surface quality:** with the Vector Grip Airless gun. Light in weight with a service life

**Tilting cart:** fast change of the container. Site-optimised tires allow convenient pump transport

**Maintenance-free, brushless direct current motor:** due to the improved performance, the motor works even more efficiently at low and also at high speeds. The continuous paint pressure measurement controls the motor speed automatically, thus ensuring a constant material pressure

**Clearly arranged - DESC-Control:** with the digital display you can read out and handle machine data, consumption figures, runtimes and much more. The intelligent deadband control, SlowMotion function and FrequentClean guarantee trouble-free work and quick cleaning

TECHNICAL DATA	PROSPRAY 3.31
Voltage	230 V / 50 Hz
Motor output	1.84 kW
Operating pressure, max.	221 bar, 22.1 MPa
Delivery rate, max.	3.8 l/min
Nozzle size, max.	0.032"
Recommended hose length, max.	60 m
Viscosity, max.	25.000 mPas
Weight	43.5 kg
Scope of delivery	Base unit ProSpray 3.31; HP hose DN6; Airless gun Vector Grip incl. TradeTip 3 nozzle holder; HEA ProTip nozzle 521
Art. No.	2308262



# PROSPRAY 3.39 SPRAYPACK

## Powerful emulsion unit for large areas

- **More power:** greater suction performance thanks to the low position of the suction valve
- **Twice as fast with emulsion:** parallel two-gun operation possible
- **The most powerful pump in the ProSpray family:** even able to cope with Airless spraying fillers
- **Innovative ProSpray product features:** tilting cart - change paints without using tools

**Superb spray surface quality:** with the Vector Grip Airless gun. Light in weight with a long service life

**No nozzle blockages:** the high pressure filter is easily accessible and quick to clean. Three different filter inserts (fine, medium, coarse) ensure an optimal match with the material

**Tilting cart:** fast change of the container. Site-optimised tires allow convenient pump transport

**Maintenance-free, brushless direct current motor:** due to the improved performance, the motor works even more efficiently at low and also at high speeds. The continuous paint pressure measurement controls the motor speed automatically, thus ensuring a constant material pressure

**Also available as filler version with Airless gun AG 19 Art. No. 2308264**

**Clearly arranged - DESC-Control:** with the digital display you can read out and handle machine data, consumption figures, runtimes and much more. The intelligent deadband control, SlowMotion function and FrequentClean guarantee trouble-free work and quick cleaning

**Low maintenance costs:** the practical, self-adjusting packings lead to less wear and are easy to change. They have a service life up to 50% longer than comparable packings



TECHNICAL DATA	PROSPRAY 3.39
Voltage	230 V / 50 Hz
Motor output	2.19 kW
Operating pressure, max.	221 bar, 22.1 MPa
Delivery rate, max.	5 l/min
Nozzle size, max.	0.039"
Recommended hose length, max.	360 m
Viscosity, max.	30.000 mPas
Weight	50 kg
Scope of delivery	Base unit ProSpray 3.39; HP hose DN6; Airless gun Vector Grip incl. TradeTip 3 nozzle holder; HEA ProTip nozzle 519; Double connector A = 1/4" NPS x 3/8" NPT; Double connector A = 3/8" NPT x A = 1/2" NPS
Art. No.	2351261



## PRACTICAL ACCESSORIES FOR ELECTRIC PISTON PUMPS

### ENAMEL KIT (DN4) FOR PROSPRAY PUMPS

Suitable for PS 20, PS 3.20, PS 3.21, PS 3.25 - Skid version.

- HP hose DN4, NPSM 1/4", max 27 MPa / 270 bar, 7.5 m
- Vector Pro gun
- Nozzle extension, G-thread, 15 cm
- FineFinish TT3 nozzle 308 (enamel)
- FineFinish TT3 nozzle 412 (filler)
- TipClean 200 ml
- Gun filter, red, extra fine, 10 pieces
- Hopper 5 litre, for ProSpray
- Hopper, filter package

SPRAYKIT	Art. No.
Enamel Kit (DN4)	2406206



HOPPER	Art. No.
Hopper, 5 litre, for PowerPainter 90 Extra	2423122
Hopper, 5 litre, for ProSpray 3.20, 20, 3.21, 3.25 Skid version	704-453

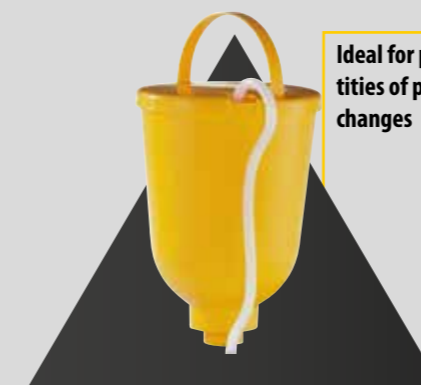

**Ideal for processing smaller quantities of paint or frequent material changes**

### 2GUN KIT – CONNECTION OF UP TO THREE GUNS ON ONE DEVICE

Suitable for: all Heavy Coat pumps, SF33 as well as PS 3.31 upwards.

- Adapter for multi-gun operation (for max. 3 guns)
- Vector Grip gun
- HP hose DN6, NPSM 1/4", 15 m, max. 27 MPa / 270 bar, 15 m
- Double connector NPSM 1/4"

SPRAYKIT	SPRAYKIT
2Gun Kit	2413598



HOSE REEL	Art. No.
Hose reel HR45, incl. 30 m HP hose DN6, for all diaphragm and piston pumps	341912



**Hose reel HR45 with hose, suitable for all diaphragm and piston pumps**





# HYDRAULIC PISTON PUMP

Even more power for suction and delivery – with denser materials

Do you mostly work with particularly high-viscosity or very dense materials? Then a WAGNER piston pump is the perfect, reliable site companion for you. The exceptionally high suction and transport power is produced by the piston's stroke movement. This is amplified even further by the hydraulic drive and is particularly ideal for this type of material.



### Various performance classes for every professional:

the especially reliable hydraulic pump technology from WAGNER is most suited to large construction sites, with a broad spectrum of applications from building protection and emulsion through to especially high-viscosity and very dense materials for use inside and out.

### A powerful companion - inside and out:

WAGNER piston pumps are available with three different drive systems. Electric piston pumps cover a wide range of performance classes and have a compact design. The hydraulic piston pumps offer even better performance and are available with a choice of either a petrol or an electric motor which can be switched in a few minutes. Pneumatically driven piston pumps from WAGNER are explosion-proof and therefore are suitable for use in workshops.

### 1. WITH EVEN MORE POWER ON THE CONSTRUCTION SITE:

The patented SSP (Special Spray Power) system from WAGNER is a technology that is unique on the market for the application of high viscosity materials. The special design of the system ensures that the pump is continually filled with sufficient material by the shovel piston. SSP is available for all HeavyCoat models.



Additional power "Special-Spray-Power" for high viscosity materials

### 2. NO CONTINUOUS RUNNING:

Piston pumps only operate when you have to build up pressure. The rest of the time, the drive is on 'standby'. This protects wear parts and has a positive impact on site noise levels.

## CROSS-SECTION OF THE PISTON



Hydraulic

Upper packing

Outlet valve

Lower packing

Inlet valve

## ADVANTAGES

- Better delivery capacity with extreme high viscosity materials
- Less sensitive to heavily filled materials
- High material pressure / material volume allow long hose lengths
- Large nozzle sizes can be used
- Extra-durable packing
- Powerful suction
- Convertible to SSP for additional power

# HEAVYCOAT 750 SPRAYPACK

Compact power pack for heavy material

- **Long service and reliability:** thanks to HydraStroke technology, the operating temperature is significantly reduced, thereby increasing the service life
- **New hydraulic design:** inspired by mining and aviation for the toughest demands in terms of the piston pump's working and delivery performance
- **Powerful:** constant performance for the application of heavy, filled and high-viscosity materials such as bitumen and textured plaster over large areas
- **Superb performance and perfect surface results:** even with long hoses
- **Maximum user-friendliness:** thanks to simple operation

**HydraStroke technology:** the operating temperature is reduced by up to 14 °C in comparison to previous hydraulic systems

**Ease of maintenance:** pump and motor are easily accessible and the lower pump can be removed by loosening just 4 screws. This makes the HC 750 particularly maintenance friendly

**Ideal cooling:** the robust design of the housing cover with integrated ventilation slots conducts air over all device components that convey hydraulic fluid

**Low valve or optionally selectable SSP shovel piston:** enable processing of extremely high-viscosity materials

**High pressure filter:** for high reliability and minimal downtime

**Quality spraying:** with the high-performance gun AG 14. When used in combination with the 2SpeedTip nozzle for fillers, it is possible to handle even high-viscosity material without difficulty

**Available as an electrically driven or petrol-driven model:** the basic model without SSP is also available with a petrol motor. This means that it can also be used on construction sites without an electrical connection

**Large pneumatic tires:** mean that the unit is easy and comfortable to transport, even on difficult terrain



TECHNICAL DATA	HEAVYCOAT 750 E	HEAVYCOAT 750 G	HEAVYCOAT 750 E SSP
Voltage	230 V / 50 Hz	-	230 V / 50 Hz
Motor output	3.1 kW	4.1 kW	3.1 kW
Operating pressure, max.	250 bar, 25 MPa	250 bar, 25 MPa	250 bar, 25 MPa
Delivery rate, max.	6 l/min	7.6 l/min	6 l/min
Nozzle size, max.	0.043"	0.041"	0.043"
Recommended max. hose length	100 m	100 m	100 m
Viscosity, max.	50.000 mPas	65.000 mPas	50.000 mPas
Weight	85 kg	81 kg	87 kg
Scope of delivery	Base unit HeavyCoat 750 E / G; HP hose DN13; Hose whip DN10; Connector I = 1/4"NPSM x A = 3/8"NPSM; 27 MPa; Airless gun AG 14 incl. TradeTip 3 nozzle holder; TradeTip 3 nozzle 539		Base unit HeavyCoat 750 E SSP; HP hose DN13; Hose whip DN10; Connector 3/8" x 1/2"; Airless gun AG 14 incl. TradeTip 3 nozzle holder; TradeTip 3 nozzle 539
Art. No.	2371027	2371029	2371028

# HEAVYCOAT 950 SPRAYPACK

## Power pack for the heaviest material

- **Versatile in use:** thanks to high delivery capacity
- **Powerful but light:** compact for ease of transport
- **Innovative HeavyCoat product features:** fast container changeovers, easy to clean and transport thanks to the swivelling SwingCart pump unit
- **SSP version:** with shovel piston for extra performance with high viscosity materials

**Quality spraying:** with the professional gun AG 14 and the TradeTip 3 nozzle for filler, high-viscosity materials can be processed without any problems

**Swing-Cart:** makes it possible to swing up the pump. Practical when working from a bucket or a container but also for transport

**Tidied up:** with the integral support hoses up to a length of 60 m can be practically stowed away

**In a single action:** the unit can be safely depressurised and quickly cleaned

**HeavyCoat special hose:** with a 3/8", 1/2" or 3/4" cross section for a better spraying performance

**You have the choice:** with or without SSP shovel piston for processing of very high-viscosity materials



TECHNICAL DATA	HEAVYCOAT 950 E	HEAVYCOAT 950 G	HEAVYCOAT 950 E SSP
Voltage	230 V / 50 Hz	-	230 V / 50 Hz
Motor output	3.6 kW	4.1 kW	3.6 kW
Operating pressure, max.	250 bar. 25 MPa	250 bar. 25 MPa	250 bar. 25 MPa
Delivery rate, max.	6.6 l/min	8 l/min	6.6 l/min
Nozzle size, max.	0.052"	0.041"	0.052"
Recommended max. hose length	100 m	100 m	100 m
Viscosity, max.	50.000 mPas	65.000 mPas	50.000 mPas
Weight	83 kg	76 kg	84.5 kg
Scope of delivery	Base unit HeavyCoat 950 E / G; HP hose DN10; Connector I = 1/4"NPSM x A = 3/8"NPSM; Airless gun AG 14 incl. TradeTip 3 nozzle holder; TradeTip 3 nozzle 443		Base unit HeavyCoat 950 E SSP; HP hose DN13; Hose whip DN10; Connector 3/8" x 1/2"; Airless gun AG 19 incl. TradeTip 3 nozzle holder; TradeTip 3 nozzle 443
Art. No.	2332184	2332186	2332187

# HEAVYCOAT 970 SPRAYPACK

## All-round Xtra speed for XL projects

- **WAGNERs most powerful hydraulic piston pump** more power with SSP
- **The perfect choice:** for large areas and intensive usage
- **Maximised capacity:** with a delivery volume of 10-12 l/min
- **Innovative HeavyCoat product features:** with a choice of either a petrol or electric motor which can be interchanged in a few minutes – or optionally even
- **SSP version:** with shovel piston for extra performance with high viscosity materials

**Quality spraying:** with the professional gun AG 14 and the TradeTip 3 nozzle for filler, high-viscosity materials can be processed without any problems

**Swing-Cart:** makes it possible to swing up the pump. Practical when working from a bucket or a container but also for transport.

**Tidied up:** with the integral support hoses up to a length of 60 m can be practically stowed away.

**With a choice of electric drive or independent of mains electricity with the Honda petrol engine:** the units can be converted from electric to petrol drive (or vice versa). This makes them able to be used on building sites with no power supply. Both motors are extremely reliable and longlasting



**Convenience:** the adjustable height telescopic handle makes for convenient transport on the building site or in the in a vehicle

**Construction-site-optimised tires:** avoid punctures and allow easy and convenient transport – even on difficult sites



TECHNICAL DATA	HEAVYCOAT 970 E	HEAVYCOAT 970 G	HEAVYCOAT 970 E SSP	HEAVYCOAT 970 G SSP
Voltage	400 V / 50 Hz	-	400 V / 50 Hz	-
Motor output	5.5 kW	6 kW	5.5 kW	6 kW
Operating pressure, max.	250 bar. 25 MPa	250 bar. 25 MPa	250 bar. 25 MPa	250 bar. 25 MPa
Delivery rate, max.	10.3 l/min	12 l/min	10.3 l/min	12 l/min
Nozzle size, max.	0.056"	0.056"	0.056"	0.056"
Recommended max. hose length	100 m	100 m	100 m	100 m
Viscosity, max.	65.000 mPas	65.000 mPas	65.000 mPas	50.000 mPas
Weight	100 kg	88 kg	103 kg	88 kg
Scope of delivery	Base unit HeavyCoat 970 E / G; HP hose DN13; Hose whip DN10; Connector 3/8" x 1/2"; Connector I = 1/4"NPSM x A = 3/8"NPSM; Airless gun AG 14 incl. TradeTip 3 nozzle holder; TradeTip 3 nozzle 443		Base unit HeavyCoat 970 E / G SSP; HP hose DN13; Hose whip DN10; Connector 3/8" x 1/2"; Airless gun AG 19 incl. TradeTip 3 nozzle holder; TradeTip 3 nozzle 443	
Art. No.	2332191	2332192	2332193	2332194

## PRACTICAL ACCESSORIES FOR HYDRAULIC PISTON PUMPS

SUCTION SYSTEMS	Art. No.
Container suction system, incl. C-coupling adaptor	349907
Reduction adaptor B- to C-coupling	9991651
Blanking plug for C coupling	97305
Container Connector, for HeavyCoat, for direct suction of the material out of the large volume container	2383128
Large volume containers (100 l)	2309956
Large volume container, incl. sack support and roller press	2309960
Sack support incl. guide rail for roller, for large volume container	2323178



Large volume container with Container Connector - For continuous work



## EMULSION KIT (DN6) FOR ALL PUMPS WITH 1/2" CONNECTORS

Incl. suitable adapter and 2x adjustable wrench.  
Suitable for PS 3.39, HC 750, HC 970, HC 950 SSP.

- Transition fitting (F) NPSM 1/2" to (M) NPMS 1/4"
- 2x HP hose DN6, NPSM 1/4", max .27 MPa / 270 bar, 15 m
- Double connector 1/4" NPSM
- Vector Grip gun
- Nozzle extension, G-thread, 15 cm
- Nozzle extension, G-thread, 30 cm
- HEA ProTip nozzle 519
- TradeTip 3 nozzle 427
- TipClean 200 ml
- 2x adjustable wrench, 250 mm
- Gun filter, white, medium, 10 pieces

SPRAYKIT	Art. No.
Emulsion Kit (DN6)	2406208



## FILLER KIT (DN10) FOR ALL PUMPS WITH 1/2" CONNECTIONS

Incl. suitable adapter and 2x adjustable wrench.  
Suitable for PS 3.39, HC 750, HC 970, HC 950 SSP.

- Transition fitting (F) NPSM 1/2" to (M) NPMS 3/8"
- HP hose DN10, NPSM 3/8", max. 25 MPa / 250 bar, 15 m
- Double connector 3/8" NPSM to 1/4" NPSM
- Airless gun AG 14, G-thread 1/4"
- Nozzle extension, G-thread, 30 cm
- TradeTip 3 nozzle 335
- TradeTip 3 nozzle 439
- TipClean 200 ml
- 2x adjustable wrench, 250 mm
- Gun filter, white, medium, 10 pieces

SPRAYKIT	Art. No.
Filler Kit (DN10)	2406209



## 2GUN KIT – CONNECTION OF UP TO THREE GUNS ON ONE DEVICE

Suitable for: all Heavy Coat pumps, SF33 as well as PS 3.31 upwards.

- Adapter for multi-gun operation (for max. 3 guns)
- Vector Grip gun
- HP hose DN6, NPSM 1/4", 15 m, max. 27 MPa / 270 bar, 15 m
- Double connector NPSM 1/4"

SPRAYKIT	SPRAYKIT
2Gun Kit	2413598



## SPIRAL PUMP

### Simple operation – powerful and versatile

Do you appreciate the machine-based application of material, especially for harder tasks? Then a spiral pump from WAGNER is exactly the strong power packet you need for your construction sites. The robust, powerful performance of a spiral pump is delivered by a really simple rotor-stator function that WAGNER has been successfully using on the market for decades.



#### Robust, faithful reliable power packet for those difficult tasks:

Spiral pumps, also called eccentric spiral pumps, use displacement mechanisms to deliver the material. Two components, the rotor and the stator, are used for this. The rotor rotates and in doing so transports the material gently through the cavities of the stator. This simple function enables extremely heavy materials with different granulation and even fibres, such as render and other materials containing fillers, to be processed extremely efficiently.

#### The solution for heavy, textured material:

WAGNER spiral pumps can be used to achieve high-quality surfaces at a high working speed, for example with machine-assisted plaster application. Here the heavy, highly viscous material is moved with the help of the spiral pump through the hose to the spray gun, where it is atomized and applied smoothly. Comfortable and controlled, just like you're used to with WAGNER airless spray devices.

#### 1. EASY TO OPERATE:

The simple, user-friendly operating concept for controlling the rotor and stator guarantees problem-free use, even for beginners.

#### 2. FAST CLEANING:

WAGNER spiral pumps can be quickly disassembled for cleaning and maintenance and reassembled again thanks to the simple stator design, including directly on the construction site. This is made especially easy on the WAGNER PlastCoat 1030 by the automatic stator withdrawal. The material-carrying parts are also made from special materials which are easy to clean.

#### 3. LONG SERVICE LIFE:

WAGNER spiral pumps are robust and easy to use. They are especially low-wear and low-maintenance, and are considerably quieter in operation than conventional piston pumps.

## CROSS-SECTION OF THE SPIRAL PUMP

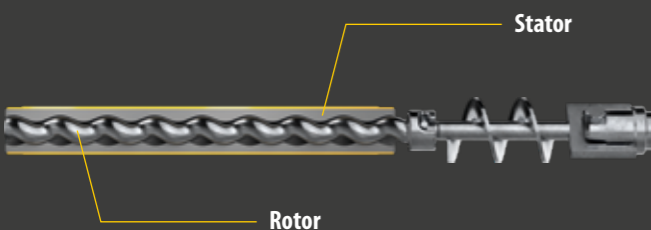

## ADVANTAGES

- Simple and sturdy technology
- Gentle material transport
- Powerful processing of highly viscous materials
- Fully adjustable control of spray pressure
- Long lifespan
- Low maintenance

## PLASTCOAT HP 30

### Uniting the best – robust high-pressure spiral pump with airless technology for high-viscosity fillers

- **Simplest handling:** the user-friendly operating concept enables error-free application - even for beginners
- **Ergonomic airless gun and high pressure hose:** guarantee a high level of operating comfort during material application
- **Maximum performance:** the **PlastCoat HP 30** provides a convincing delivery capacity of >10kg/min. The spraying pressure can also be freely adjusted (40-120 bar)
- **Exceptionally reliable:** the low-wear and low-main-tenance spiral pump is characterised by its robust and proven technology

**Plastic material hopper:** easy to clean and with a capacity of 50 litres. Cover for the material hopper available separately as an accessory (Art. No. 2400 030)

**Compact dimensions:** with a height of 62 cm, the device can easily be filled with material

**Easy control:** thanks to the user friendly control panel

**High-performance guns:** with the airless gun AG 19, even high-viscosity materials can be processed without any problems

**Colour-coded pressure gauge:** allows perfect control of the pressure in coordination with the material being processed

**Perfect for every construction site:** the large, pneumatic tires ensure mobility on any construction site

**Quiet and comfortable Airless spraying:** without additional compressor with up to 120 bar working pressure

**Also available as emulsion version. Art. No. 2400684**

**HEA HIGH EFFICIENCY AIRLESS**

**Can easily be converted for emulsion work:** with the emulsion kit comprising a 15 m hose (DN10) and the Vector Pro gun with HEA nozzle 517 (2400684)

TECHNICAL DATA	PLASTCOAT HP 30
Voltage	230 V / 50 Hz
Motor output	2.3 kW
Operating pressure, max.	120 bar, 12 MPa
Delivery rate, max.	> 10 l/min
Nozzle size, max.	0.055"
Recommended hose length, max.	22.5 m
Weight	72 kg
Scope of delivery	Base unit PC HP 30; HP hose DN6; HP whip hose DN10; Airless gun AG 19 incl. TradeTip 3 nozzle holder; TradeTip 3 nozzle 443; PlastGuard longlasting pump protector
Art. No.	2388301



# PLASTCOAT 1030 E SPRAYPACK

The power to handle large volumes – compact and versatile

- **Compact and lightweight:** 58 kg of weight with a delivery height of 20 m and delivery radius of 40 m, materials up to a grain size of 6 mm supported
- **For large surfaces and easy transport:** integrated 50-litre plastic container, four wheels
- **Easy cleaning for use on building sites:** automatic stator extraction and automatic pressure release
- **Maintenance-free and robust:** brushless DC motor for a high torque
- **Closing the gun turns off the pump (electrically)**

**Compact dimensions:** with a height of 62 cm the unit can be easily filled using buckets or combined with a flow mixer

**Automatic stator extraction:** fast separation of pump and suction system, also great for quick assembly. Ideal for easy cleaning and transport

**Plastic materialhopper:** for an easy cleaning with a capacity of up to 50 litre

**Included in scope of delivery:** PC 1030 comes complete ready to spray incl. mortar hose (DN25, 10 m), automatic spraying lance with nozzle and toolbox.

**Perfectly equipped for all construction sites:** big, pneumatic tires ensures mobility on all construction sites

**Ergonomic spraying lance:** due to its modular construction and accessories (e.g. the lance extension) the spraying lance can adapt quickly to any project

TECHNICAL DATA	PLASTCOAT 1030 E
Voltage	230 V / 50 Hz
Motor output	2.2 kW
Operating pressure, max.	40 bar, 4 MPa
Delivery rate, max.	15 l/min
Grain size, max.	K6mm
Recommended hose length, max.	40 m
Weight	59 kg
Scope of delivery	Base unit PC HP 1030 E; Mortar hose DN25 incl. air hose and control cable; Spraying lance, automatic, incl. 6 mm nozzle; Pump lubricant, 500 ml
Art. No.	2361588



## PRACTICAL ACCESSORIES HP 30

HOSES	Art. No.
HP hose DN19, 10 m	2390763
HP Hose whip, DN10, 2.5 m	2390762
HP hose DN10, max. 25 MPa, NPSM 3/8", 15 m	2336583

SPRAY GUNS AND NOZZLES	Art. No.
Airless gun AG 19, 25 MPa, G-thread 3/8", incl. TradeTip 3 nozzle holder	2341127
Airless gun Vector Pro, 1/4", incl. TradeTip3 nozzle holder, with 4-trigger	538040
TradeTip 3 nozzles	553xxx
HEA ProTip nozzles	554xxx
Nozzle holder, G-thread 7/8", for TradeTip 3 nozzles	289390

OTHER	Art. No.
Nozzle extension, with holder, without nozzle, 25 cm	2418854
Nozzle extension, with holder, without nozzle, 50 cm	2418855
Cleaning ball DN16	2402355
Cleaning ball DN19	342330
Rotor and stator, complete, for PlastCoat HP 30	2395996
Cover for material hopper	2400030
Press table	2389048
PlastGuard longlasting pump protector, 5 l	2399960



## PRACTICAL ACCESSORIES PC 1030

MORTAR HOSES, INCL. AIR HOSE AND CONTROL CABLE	Art. No.
Mortar hose DN19, V/M 27, 2 m incl. swivel joint	2334131
Mortar hose DN19, V/M 27, 10 m	2325193
Mortar hose DN25, V/M 27, 10 m	2325197
Mortar hose DN35, V/M 35, 13.3 m	2325199

NOZZLES	Art. No.
Structure nozzle, stainless steel, 4 mm	268779
Structure nozzle, stainless steel, 6 mm	268780
Structure nozzle, stainless steel, 8 mm	268781
Structure nozzle, stainless steel, 10 mm	268782
Structure nozzle, stainless steel, 12 mm	342327
Structure nozzle, stainless steel, 15 mm	342328

ROTOR-STATOR KITS	Art. No.
Rotor, D 6 - 2.5, 7.5 l/min delivery rate, max.	348312
Stator, D 6 - 2.5, 7.5 l/min delivery rate, max., black	348311
Rotor, D 6 - 3, 10 l/min delivery rate, max.	348316
Stator, D 6 - 3, 10 l/min delivery rate, max., yellow	348315
Rotor, D 7 - 2, 15 l/min delivery rate, max.	348926
Stator, D 7 - 2, 15 l/min delivery rate, max., brown	348925
Rotor, D 8 - 1.5, 20 l/min delivery rate, max.	2389048
Stator, D 8 - 1.5, 20 l/min delivery rate, max., green	2399960



**PRESS TABLE**  
Our handy helper for the fast processing of bagged goods is available separately as an accessory (Art. No. 2389048).

## TEMPSPRAY AIRLESS HEATED HOSE

### Optimised for spraying highly viscous materials without dilution

Would you always like to ensure the ideal processing temperature and best viscosity of the material you are spraying, regardless of any seasonal fluctuations in temperature? The Temp-Spray heated hose from WAGNER is your guarantee for the best possible surface quality. The electric heating element, located directly in the flow of paint inside the hose system, heats the material evenly over the entire length of the hose to the pre-set temperature.



#### Heat up instead of diluting:

The ideal viscosity, along with the right working technique and equipment, are crucial for impressive results when spraying. If material is too thick, the result is an irregular spray pattern and a poor paint application. To make coating materials sprayable they usually have to be diluted. Heating the material with a TempSpray heated hose system from WAGNER has the same effect: viscosity is reduced, improving the application of the material. The result is a soft spray pattern and optimised atomisation quality.

#### Perfectly equipped for every area of application:

Heating the material in the heated hose improves the spraying properties of numerous coating materials - from stains and lacquers through to adhesives. The TempSpray systems can be fully controlled from 20° to 60°C. They can be used with all WAGNER airless devices, offering a broad range of applications.

#### 1. LESS SOLVENT, VOC-COMPLIANT:

Heating the material reduces the amount of solvent needed since the material no longer needs to be diluted to achieve the required spray viscosity.

#### 2. LOWER SPRAY PRESSURE:

Heating reduces the material's viscosity, allowing a lower spray pressure to be used. This reduces the overspray, protects the device being used and also protects the operator.

## CHANGE IN VISCOSITY

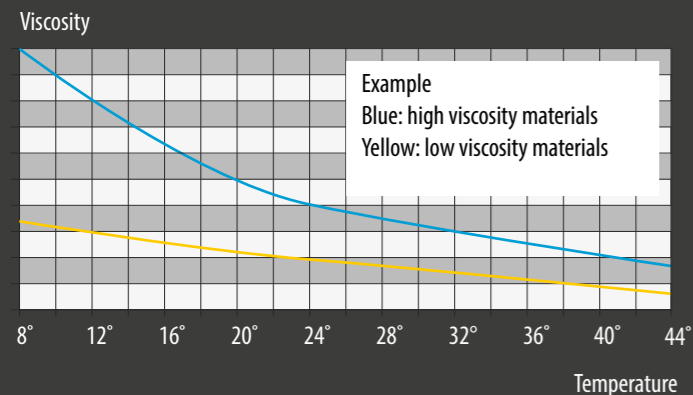

## ADVANTAGES

- Easy to use
- Reduction of overspray
- Paint savings thanks to less overspray
- Increase in the thickness of the layers applied
- Less wear and tear on the device
- Constant paint temperature, even when outdoor temperatures are low
- Excellent edge coverage

## TEMPSPRAY H 126 SPRAYPACK

The system that simplifies your work – perfect surface finishes through reduced viscosity with material heating

- **Easy to use:** specially designed for paint jobs, easily adapted for use with all Airless devices
- **Effortless operation:** flexible, steel-reinforced DN6 hose
- **Flexible:** continuous temperature regulation from 20° C - 60° C.
- **Lightweight:** weighs only 3.5 kg
- **Suitable for the following materials:** wood preservative, oils, stains, primers, undercoats, fillers, lacquers, 2K materials (Check the pot life).

**Spray with excellent surface quality:** the Vector Grip Airless gun is lightweight and has a long service life

**Clearly laid-out control unit:** the required temperature can be fully adjusted from 20° C to 60° C as needed by pressing the arrow buttons.

**Perfect surface finish with Temp-Spray:** heating of the coating material produces a soft spray pattern and therefore perfect atomisation. Other advantages include less overspray, perfect viscosity without dilution and much more.

**Compact unit:** thanks to integrated heating element

**Flexible and robust:** 10 m long DN6 stainless steel hose

**Also available as a base unit for combining with existing Airless guns.**  
Art. No. 2311659

**Also ideal in combination with AirCoat for very fine atomisation**

TECHNICAL DATA	TEMPSPRAY H 126
Voltage	230 V / 50 Hz
Heating power	0.6 kW
Operating pressure, max.	250 bar, 25 MPa
Temperature control	20 - 60 °C
Recommended hose length, max.	10 m
Viscosity, max.	5.000 mPas
Power connection cable	4 m
Scope of delivery	TempSpray H 126 basic until 10 m; Airless gun Vector Grip incl. TradeTip 3 nozzle holder; TradeTip 3 FineFinish nozzle 410
Art. No.	2311852



# TEMPSPRAY H 226 SPRAYPACK

Practical material heating system – for emulsions and latex paints

- **Specially designed for emulsions, latex paints**
- **Practical:** trolley-mounted hose reel for simple transportation on building sites
- **Flexible:** for indoor and outdoor use, easily adapted to all Airless units
- **Suitable for the following materials:** thick materials, high solids, emulsion paints, latex paints, exterior protection, roof coatings



**Spray with excellent surface quality:** the Airless Gun AG 14 is robust and has a long service life

**Mobile:** thanks to construction site-compatible reel drum

**Also available as a base unit for combining with existing Airless guns**  
Art. No. 2311660

**Clearly laid-out control unit:** the required temperature can be fully adjusted from 20°C to 60°C as needed by pressing the arrow buttons

**Perfect surface finish with TempSpray:** heating of the coating material produces a soft spray pattern and therefore perfect atomisation. Other advantages include less overspray, perfect viscosity without dilution and much more



TECHNICAL DATA	TEMPSPRAY H 226
Voltage	230 V / 50 Hz
Heating power	1.3 kW
Operating pressure, max.	250 bar, 25 MPa
Temperature control	20 - 60 °C
Recommended hose length, max.	15 m
Viscosity, max.	25.000 mPas
Power connection cable	6 m
Scope of delivery	TempSpray H 226 base unit 15 m; Airless gun AG 14 incl. TradeTip 3 nozzle holder; HEA ProTip nozzle 517
Art. No.	2311853



# TEMPSPRAY H 326 SPRAYPACK

The longest TempSpray of all time – for extended versatility and working radius

- **Ideal for emulsions, masonry, facade paints**
- **Twice the working radius for indoor and outdoor work:** 30 m heated hose
- **Practical:** large trolley-mounted hose reel for simple transportation on building sites
- **Suitable for the following materials:** thick materials, high solids, emulsion paints, latex paints, exterior



**Spray with excellent surface quality:** the Airless Gun AG 14 is robust and has a long service life

**Mobile:** thanks to construction site-compatible reel drum and extra-long hose (30 m)

**Also available as a base unit for combining with existing Airless guns**  
Art. No. 2311661

**Clearly laid-out control unit:** the required temperature can be fully adjusted from 20°C to 60°C as needed by pressing the arrow buttons

**Perfect surface finish with TempSpray:** heating of the coating material produces a soft spray pattern and therefore perfect atomisation. Other advantages include less overspray, perfect viscosity without dilution and much more



TECHNICAL DATA	TEMPSPRAY H 326
Voltage	230 V / 50 Hz
Heating power	1.1 kW
Operating pressure, max.	250 bar, 25 MPa
Temperature control	20 - 60 °C
Recommended hose length, max.	30 m
Viscosity, max.	25.000 mPas
Power connection cable	6 m
Scope of delivery	TempSpray H 326 base unit 30 m; Airless gun AG 14 incl. TradeTip 3 nozzle holder; HEA ProTip nozzle 521
Art. No.	2311854



	FINISHCONTROL 3500	FINISHCONTROL 5500	FINECOAT 9700	FINECOAT 9900 PLUS	SUPERFINISH 23 PRO HEA
Product image (may differ)					
Spraying method					
Technology					
Drive					
Voltage	230 V / 50 Hz	230 V / 50 Hz	230 V / 50 Hz	230 V / 50 Hz	230 V / 50 Hz
Motor output	0.7 kW	1.15 kW	1.15 kW	1.5 kW	1.3 kW
Operating pressure, max.	0.2 bar, 0.02 MPa	0.29 bar, 0.029 MPa	0.3 bar, 0.03 MPa	0.72 bar, 0.072 MPa	250 bar, 25 MPa
Delivery rate, max.	-	-	-	-	2.6 l/min
Nozzle size, max.	-	-	-	-	0.023"
Recommended hose length, max.	-	-	-	-	30 m
Viscosity, max.	-	-	-	-	20.000 mPas
Weight	2.3 kg	6.6 kg	6.8 kg	15 kg	27 kg
Art.-No.	2341501	2422986	2426601	276048	2399198
Suitable material					
Suitable material - additional accessories are needed					
Recommended intensity					

	SUPERFINISH 23 PLUS HEA	SUPERFINISH 23 PLUS AIRLESS ENAMEL	SUPERFINISH 23 PLUS TEMPSRAY	SUPERFINISH 23 PLUS AIRCOAT ENAMEL	SUPERFINISH 23 CR
Product image (may differ)					
Spraying method					Injection
Technology					
Drive					
Voltage	230 V / 50 Hz	230 V / 50 Hz	230 V / 50 Hz	230 V / 50 Hz	230 V / 50 Hz
Motor output	1.3 kW	1.3 kW	1.3 kW	1.3 kW	1.3 kW
Operating pressure, max.	250 bar, 25 MPa	250 bar, 25 MPa	250 bar, 25 MPa	250 bar, 25 MPa	250 bar, 25 MPa
Delivery rate, max.	2.6 l/min	2.6 l/min	2.6 l/min	2.6 l/min	2.6 l/min
Nozzle size, max.	0.023"	0.023"	0.023"	0.023"	-
Recommended hose length, max.	30 m	30 m	10 m	7.5 m	15 m
Viscosity, max.	20.000 mPas	20.000 mPas	20.000 mPas	20.000 mPas	20.000 mPas
Weight	29 kg	29 kg	29 kg	29 kg	29 kg
Art. No.	2384153	2341492	2341496	2353393	2415601
Suitable material					
Suitable material - additional accessories are needed					
Recommended intensity					

Water and solvent-based paints, lacquers, oils, separating agents

Synthetic resin lacquers, PVC lacquers, 2K lacquers

Primers, fillers

Small objects up to 50 m<sup>2</sup>

Residential 50 m<sup>2</sup> - 200 m<sup>2</sup>

Large residential 200 m<sup>2</sup> - 800 m<sup>2</sup>

Commercial more than 800 m<sup>2</sup>

Fire protection, rust protection paints

Emulsion and latex paints, adhesives, sealants

Exterior paints, roof coatings, floor coatings, textured paint

XVLP / HVLP

AirCoat

Airless

Plaster spraying

Structural waterproofing, bituminous coatings

Filler

Plaster

Piston pump

Diaphragm pump

Turbine

Spiral pumps

Injection

Electric

Petrol-driven

TempSpray



	SUPERFINISH 33 PRO	SUPERFINISH 33 PLUS	POWERPAINTER 90 EXTRA SKID VERSION	POWERPAINTER 90 EXTRA CART VERSION	PROSPRAY 3.20 HEA
Product image (may differ)					
Spraying method					
Technology					
Drive					
Voltage	230 V / 50 Hz	230 V / 50 Hz	230 V / 50 Hz	230 V / 50 Hz	230 V / 50 Hz
Motor output	2.2 kW	2.2 kW	0.8 kW	0.8 kW	1.0 kW
Operating pressure, max.	250 bar, 25 MPa	250 bar, 25 MPa	200 bar, 20 MPa	200 bar, 20 MPa	207 bar, 20.7 MPa
Delivery rate, max.	4.3 l/min	4.3 l/min	1.9 l/min	1.9 l/min	2 l/min
Nozzle size, max.	0.033"	0.033"	0.019"	0.019"	0.021"
Recommended hose length, max.	60 m	60 m	15 m	15 m	30 m
Viscosity, max.	25.000 mPas	25.000 mPas	-	-	20.000 mPas
Weight	43 kg	50 kg	10,2 kg	25.2 kg	13.6 kg
Art. No.	2388260	2388259	2414079	2401275	2412438
Suitable material					
Suitable material - additional accessories are needed					
Recommended intensity					

	PROSPRAY 3.21 HEA	PROSPRAY 3.25	PROSPRAY 3.31	PROSPRAY 3.39 EMULSION	PROSPRAY 3.39 FILLER
Product image (may differ)					
Spraying method					
Technology					
Drive					
Voltage	230 V / 50 Hz	230 V / 50 Hz	230 V / 50 Hz	230 V / 50 Hz	230 V / 50 Hz
Motor output	1.035 kW	1.1 kW	1.84 kW	2.19 kW	2.19 kW
Operating pressure, max.	221 bar, 22.1 MPa	221 bar, 22.1 MPa	221 bar, 22.1 MPa	221 bar, 22.1 MPa	221 bar, 22.1 MPa
Delivery rate, max.	2 l/min	2.6 l/min	3.8 l/min	5 l/min	5 l/min
Nozzle size, max.	0.023"	0.027"	0.032"	0.039"	0.039"
Recommended hose length, max.	30 m	30 m	60 m	60 m	60 m
Viscosity, max.	20.000 mPas	25.000 mPas	25.000 mPas	30.000 mPas	30.000 mPas
Weight	17.9 kg	27.4 kg	43.5 kg	50 kg	50 kg
Art. No.	532089	2308260	2308262	2351261	2308264
Suitable material					
Suitable material - additional accessories are needed					
Recommended intensity					

Water and solvent-based paints, lacquers, oils, separating agents

Synthetic resin lacquers, PVC lacquers, 2K lacquers

Primers, fillers

Small objects up to 50 m<sup>2</sup>

Residential 50 m<sup>2</sup> - 200m<sup>2</sup>

Large residential 200 m<sup>2</sup> - 800m<sup>2</sup>

Commercial more than 800m<sup>2</sup>

Fire protection, rust protection paints

Emulsion and latex paints, adhesives, sealants

Exterior paints, roof coatings, floor coatings, textured paint

XVLP / HVLP

AirCoat

Airless

Plaster spraying

Structural waterproofing, bituminous coatings

Filler

Plaster

Piston pump

Diaphragm pump

Turbine

Spiral pumps

Injection

Electric

Petrol-driven

TempSpray

	HEAVYCOAT 750 E / E SSP	HEAVYCOAT 750 G	HEAVYCOAT 950 E / E SSP	HEAVYCOAT 950 G	HEAVYCOAT 970 E / E SSP
Product image (may differ)					
Spraying method					
Technology					
Drive					
Voltage	230 V / 50 Hz	230 V / 50 Hz	230 V / 50 Hz	230 V / 50 Hz	400 V / 50 Hz
Motor output	3.1 kW	4.1 kW	3.6 kW	4.1 kW	5.5 kW
Operating pressure, max.	250 bar, 25 MPa	250 bar, 25 MPa	250 bar, 25 MPa	250 bar, 25 MPa	250 bar, 25 MPa
Delivery rate, max.	6 l/min	7.6 l/min	6.6 l/min	8 l/min	10.3 l/min
Nozzle size, max.	0.043"	0.041"	0.052"	0.052"	0.056"
Grain size, max.	-	-	-	-	-
Recommended hose length, max.	100 m	100 m	100 m	100 m	100 m
Viscosity, max.	50.000 mPas	65.000 mPas	50.000 mPas	50.000 mPas	65.000 mPas
Weight	85 kg / 87 kg	81 kg	83 kg / 84.5 kg	76 kg	100 kg / 103 kg
Art. No.	2371027 / 2371028	2371029	2332184 / 2332187	2332186	2332191 / 2332193
Suitable material					
Recommended intensity					

	HEAVYCOAT 970 G / G SSP	PLASTCOAT HP 30	PLASTCOAT 1030 E
Product image (may differ)			
Spraying method			
Technology			
Drive			
Voltage	400 V / 50 Hz	230 V / 50 Hz	230 V / 50 Hz
Motor output	6 kW	2.3 kW	2.2 kW
Operating pressure, max.	250 bar, 25 MPa	120 bar, 12 MPa	40 bar, 4 MPa
Delivery rate, max.	12 l/min	> 10 kg/min	15 l/min
Nozzle size, max.	0.056"	0.055"	-
Grain size, max.	-	-	K6 mm
Recommended hose length, max.	100 m	22.5 m	40 m
Viscosity, max.	65.000 mPas	-	-
Weight	88 kg	72 kg	59 kg
Art. No.	2332192 / 2332194	2388301	2361588
Suitable material			
Recommended intensity			

Water and solvent-based paints, lacquers, oils, separating agents

Synthetic resin lacquers, PVC lacquers, 2K lacquers

Primers, fillers

Small objects up to 50 m<sup>2</sup>

Residential 50 m<sup>2</sup> - 200m<sup>2</sup>

Large residential 200 m<sup>2</sup> - 800m<sup>2</sup>

Commercial more than 800m<sup>2</sup>

Fire protection, rust protection paints

Emulsion and latex paints, adhesives, sealants

Exterior paints, roof coatings, floor coatings, textured paint

XVLP / HVLP

AirCoat

Airless

Plaster spraying

Structural waterproofing, bituminous coatings

Filler

Plaster

Piston pump

Diaphragm pump

Turbine

Spiral pumps















Injection

Electric

Petrol-driven

TempSpray

	TEMPSPRAY H 126 BASE UNIT	TEMPSPRAY H 126 SPRAYPACK
Product image (may differ)		
Spraying method	-	
Technology		
Drive		
Voltage	230 V / 50 Hz	230 V / 50 Hz
Heating power	0.6 kW	0.6 kW
Operating pressure, max.	250 bar, 25 MPa	250 bar, 25 MPa
Temperature control	20 - 60 °C	20 - 60 °C
Recommended hose length, max.	10 m	10 m
Viscosity, max.	5.000 mPas	5.000 mPas
Weight	3.2 kg	-
Power connection cable	4 m	4 m
Art. No.	2311659	2311852

	TEMPSPRAY H 226 BASE UNIT	TEMPSPRAY H 226 SPRAYPACK	TEMPSPRAY H 326 BASE UNIT	TEMPSPRAY H 326 SPRAYPACK
Product image (may differ)				
Spraying method	-		-	
Technology				
Drive				
Voltage	230 V / 50 Hz	230 V / 50 Hz	230 V / 50 Hz	230 V / 50 Hz
Heating power	1.3 kW	1.3 kW	1.1 kW	1.1 kW
Operating pressure, max.	250 bar, 25 MPa	250 bar, 25 MPa	250 bar, 25 MPa	250 bar, 25 MPa
Temperature control	20 - 60 °C	20 - 60 °C	20 - 60 °C	20 - 60 °C
Recommended hose length, max.	15 m	15 m	30 m	30 m
Viscosity, max.	25.000 mPas	25.000 mPas	25.000 mPas	25.000 mPas
Weight	18 kg	-	23 kg	-
Power connection cable	6 m	6 m	6 m	6 m
Art. No.	2311660	2311853	2311661	2311854

 Water and solvent-based paints, lacquers, oils, separating agents

 Synthetic resin lacquers, PVC lacquers, 2K lacquers

 Primers, fillers

 Small objects up to 50 m<sup>2</sup>

 Residential 50 m<sup>2</sup> - 200m<sup>2</sup>

 Large residential 200 m<sup>2</sup> - 800m<sup>2</sup>

 Commercial more than 800m<sup>2</sup>

 Fire protection, rust protection paints

 Emulsion and latex paints, adhesives, sealants

 Exterior paints, roof coatings, floor coatings, textured paint

 XVLP / HVLP

 AirCoat

 Airless

 Plaster spraying

 Structural waterproofing, bituminous coatings

 Filler

 Plaster

 Piston pump

 Diaphragm pump

 Turbine

 Spiral pumps

 Injection

 Electric

 Petrol-driven

 TempSpray

## WAGNER ACCESSORIES

Perfectly equipped for every application

WAGNER offers innovative accessories which offer extended possibilities for the use of your system. These include the practical interior-fed paint roller for effective processing of emulsions indoors and outdoors as well as a wide range of accessories to make your daily work easier. On the following pages you will find a selection of our accessories.

### THE FULL RANGE OF ACCESSORIES

You can find an overview of the entire range of accessories online at [www.wagner-group.com](http://www.wagner-group.com) or in our separate accessories brochure. Our service staff or specialist dealers will be happy to answer any specific questions you may have.



## AILRESS SPRAYKITS

Perfectly tailored to every application

WAGNER SprayKits are specially adjusted accessory packages that expand the application range of your spraying unit.

### ENAMEL KIT (DN4) FOR ALL SUPERFINISH PUMPS

Suitable for SF 23 Plus, SF 33, SF 27, SF 31.

- HP hose DN4, NPSM 1/4", max. 27 MPa / 270 bar, 7.5 m
- Vector Pro gun
- Nozzle extension, G-thread, 15 cm
- FineFinish TT3 nozzle 308 (enamel)
- FineFinish TT3 nozzle 412 (filler)
- TipClean 200 ml
- Gun filter, red, extra fine, 10 pieces
- Hopper 5 litre, M36 x 2

#### SPRAYKIT

Enamel Kit (DN4)

#### Art. No.

2406207



### ENAMEL KIT (DN4) FOR PROSPRAY PUMPS

Suitable for PS 20, PS 3.20, PS 3.21, PS 3.25 on skid.

- HP hose DN4, NPSM 1/4", 7.5 m, max. 27 MPa / 270 bar
- Vector Pro gun
- Nozzle extension, G-thread, 15 cm
- FineFinish TT3 nozzle 308 (enamel)
- FineFinish TT3 nozzle 412 (filler)
- TipClean 200 ml
- Gun filter, red, extra fine, 10 pieces
- Hopper 5 litre, for ProSpray
- Hopper filter package

#### SPRAYKIT

Enamel Kit (DN4)

#### Art. No.

2406206



## HEA KIT (DN6) FOR ALL PUMPS WITH 1/4" CONNECTORS

Suitable for all SuperFinish and ProSpray pumps, as well as PowerPainter 90

- HP hose DN6, NPSM 1/4", max. 27 MPa / 270 bar, 15 m
- Vector Pro gun
- Nozzle extension; G-thread; 15 cm
- HEA ProTip nozzle 517
- HEA ProTip nozzle 311
- TipClean 200 ml
- Gun filter, white, medium, 10 pieces

SPRAYKIT	Art. No.
HEA Kit (DN6)	2408212



## EMULSION KIT (DN6) FOR ALL PUMPS WITH 1/2" CONNECTORS

Incl. suitable adapter and 2x adjustable wrench.  
Suitable for PS 3.39, HC 750, HC 970, HC 950 SSP.

- Transition fitting (F) NPSM 1/2" to (M) NPMS 1/4"
- 2x HP hose DN6, NPSM 1/4", max. 27 MPa / 270 bar, 15 m
- Double connector 1/4" NPSM
- Vector Grip gun
- Nozzle extension, G-thread, 15 cm
- Nozzle extension, G-thread, 30 cm
- HEA ProTip nozzle 519
- TradeTip 3 nozzle 427
- TipClean 200 ml
- 2x adjustable wrench, 250 mm
- Gun filter, white, medium, 10 pieces

SPRAYKIT	Art. No.
Emulsion Kit (DN6)	2406208



## EMULSION KIT (DN10) FOR PLASTCOAT HP 30

With HEA technology, PC HP 30 can also be used to apply emulsion paints with the best surface quality.

- HP hose DN10, max. 25 MPa / 250 bar, NPSM 3/8", 15 m
- Vector Pro gun
- HEA ProTip nozzle 517
- Adapter FM 1/2BSP-3/8NPSM
- Adapter FM 1/4 NPSM-3/8NPSM

SPRAYKIT	Art. No.
Emulsion Kit (DN10)	2400684



## FILLER KIT (DN10) FOR ALL PUMPS WITH 1/2" CONNECTIONS

Incl. suitable adapter and 2x adjustable wrench.  
Suitable for PS 3.39, HC 750, HC 970, HC 950 SSP.

- Transition fitting (F) NPSM 1/2" to (M) NPMS 3/8"
- HP hose DN10, NPSM 3/8", max. 25 MPa / 250 bar, 15 m
- Double connector 3/8" NPSM to 1/4" NPSM
- Airless gun AG 14, G-thread 1/4"
- Nozzle extension, G-thread, 30 cm
- TradeTip 3 nozzle 335
- TradeTip 3 nozzle 439
- TipClean 200 ml
- 2x adjustable wrench, 250 mm
- Gun filter, white, medium, 10 pieces

SPRAYKIT	Art. No.
Filler Kit (DN10)	2406209



## 2GUN KIT - CONNECTION OF UP TO THREE GUNS ON ONE DEVICE

Suitable for: all Heavy Coat pumps, SF33 as well as PS 3.31 upwards.

- Adapter for multi-gun operation (for max. 3 guns)
- Vector Grip gun
- HP hose DN6, NPSM 1/4", 15 m, max. 27 MPa / 270 bar, 15 m
- Double connector NPSM 1/4"

SPRAYKIT	Art. No.
2Gun Kit	2413598











# ACCESSORIES – AIRLESS NOZZLES

## The heart of the spraying process

Across all technologies – Airless, AirCoat, plaster spraying with worm pumps, HVLP or XVL P – nozzles and air caps play a decisive role in surface quality. In addition to the actual pump, they are the true heart of the spraying process. This is where the material is atomised and where the fineness of the droplet formation in the spray pattern is determined. The nozzle size also determines the quantity of material forced through the bore. Top-quality nozzles are a prerequisite for premium surface finishes in line with your professional standards.



	Water and solvent-based lacquers, lacquer paints, oils, separating agents		Synthetic resin lacquers, PVC lacquers, 2K lacquers		Primers, fillers
	Fire protection, rust protection paints		Emulsion and latex paints, adhesives, sealants		Exterior paints, roof coatings, floor coatings, textured paint
	Structural waterproofing, bituminous coatings		Filler		Plaster



Art. No. 553xxx

## AIRLESS TRADETIP 3 NOZZLES – PERFECT AND DURABLE

The yellow standard nozzle offers a wide range of applications for processing primers, lacquers, glazes, emulsion paints, fire and rust protection paints up to airless filler.

Jet width (mm)*	Orifice size (inch)																										
	0.007	0.009	0.011	0.013	0.015	0.017	0.019	0.021	0.023	0.025	0.027	0.029	0.031	0.033	0.035	0.039	0.043	0.045	0.051	0.052	0.055	0.061	0.063	0.065	0.067		
100	107	109	111	113	115	117																					
120	207	209	211	213	215	217	219	221	223	225	227	229	231	233	235		243				252		261	263		267	
150	307	309	311	313	315	317	319	321	323	325	327	329	331	333	335												
190	407	409	411	413	415	417	419	421	423	425	427	429	431	433	435	439	443	445	451		455	461	463		467		
225		509	511	513	515	517	519	521	523	525	527	529	531	533	535	539	543	545	551		555	561		565			
270		609	611	613	615	617	619	621	623	625	627	629	631	633	635	639	643		651		655	661		665			
300					715	717	719	721	723	725				731		735											
330				813	815	817	819	821	823	825	827		831														
385							919																				
Flow rate (l/min)**	0.19	0.34	0.45	0.68	0.91	1.17	1.47	1.78	2.15	2.53	2.95	3.44	3.89	4.42	4.99	6.20	7.52	8.24	10.58								
Filter	red			yellow			white						green														



Art. No. 554xxx

## HEA PROTIP NOZZLES – UP TO 55 % LESS OVERSPRAY

The new WAGNER HEA ProTip airless nozzle provides a perfect surface finish at reduced spraying pressure. Compared to standard airless technology the spray pattern is gently feathered and free from edge strips.

Jet width (mm)*	Orifice size (inch)						Spray angle in °
	0.011	0.013	0.015	0.017	0.019	0.021	
120	211	213					20
150	311	313					30
190	411	413	415	417		421	40
225			515	517	519	521	50
270			615	617	619	621	60
Flow rate (l/min)**	0.45	0.68	0.91	1.17	1.47	1.78	
Filter	red		yellow		white		



Art. No. 554xxx

## AIRLESS TRADETIP 3 FINEFINISH NOZZLES

Top paint nozzle with optimised third-generation properties. With double special core for ultra-fine droplet formation and exceptionally high-quality surfaces, even in low pressure ranges. FineFinish nozzles are coloured purple.

Jet width (mm)*	Orifice size (inch)				Spray angle in °
	0.008	0.010	0.012	0.014	
120	208	210	212	214	20
150	308	310	312	314	30
190	408	410	412	414	40
225		510	512	514	50
Flow rate (l/min)**	0.26	0.42	0.6	0.79	
Filter	red				

\* Spray width (mm) at approx. 30 cm distance from the object and 100 bar pressure, with synthetic resin paint, 20 DIN seconds  
 \*\* Measured with water at 120 bar pressure



## AIRLESS NESPRI TWIN TIP NOZZLES

For mist-free spraying: NESPRI TwinTip nozzles have two nozzle orifices one directly above the other – For a perfect spray pattern with high material throughput even in low pressure ranges. Guaranteed mist-free thanks to the use of the NESPRI spray device in combination with the NESPRI TwinTip and NESPRI paints from Caparol. Different sizes are available to adapt ideally to the relevant environment.

Art. No. 1009xxx

Jet width (mm)*	Orifice size (inch)				Spray angle in °
	0.013	0.021	0.23	0.027	
100		215			20
110	213 ***				20
130		316	317	319	30
Filter	white				

\*\*\* Mono nozzle for trimming jobs



Art. No. 90xxx

## AIRLESS STANDARD FAN NOZZLES

Airless standard flat jet nozzle are especially suitable for painting applications, but can be used also for high viscosity materials. They are ideal for the fast processing of large quantities of material. The high-quality nozzles are robust and suitable for all common Airless guns.

Jet width (mm)*	Orifice size (inch)																
	0.007	0.009	0.011	0.013	0.015	0.017	0.019	0.021	0.023	0.025	0.027	0.030	0.031	0.035	0.039	0.043	0.051
90			111		115												
100			211	113	215												
120			311	213		217			223	225				235			
150		209		313		317	219	221			227					243	
160	407	309			315		319										
190	507	409				417	419	421	423	425							
215		509	411	413	415								431				
225		609	511			517					427	531	435				
250					515			521	523	525	527						
270			611	513	615		519			625	627		631	535		543	552
300				613	715	617	619		623			629		635			
330						717	719	621	723			827					
385				813	815			821	823	825							
400							819										
480															839		
Flow rate (l/min)**	0.19	0.34	0.49	0.68	0.91	1.17	1.47	1.78	2.15	2.53	2.95	3.44	3.89	4.99	6.2	7.52	11.0
Filter	red		red/yellow		yellow		yellow/white		white			green					

\* Spray width (mm) at approx. 30 cm distance from the object and 100 bar pressure, with synthetic resin paint, 20 DIN seconds  
 \*\*\* Measured with water at 120 bar pressure

Water and solvent-based lacquers, lacquer paints, oils, separating agents

Synthetic resin lacquers, PVC lacquers, 2K lacquers

Primers, fillers

Fire protection, rust protection paints

Emulsion and latex paints, adhesives, sealants

Exterior paints, roof coatings, floor coatings, textured paint

Structural waterproofing, bituminous coatings

Filler

Plaster

## ACCESSORIES – AIRLESS

### AIRLESS GUN VECTOR INFINITY Art. No.

Vector Infinity with G-thread 1/4", incl. TradeTip 3 nozzle holder, 34.5 MPa (345 bar) with 2-finger trigger and adaptable hand grip 538085

Small grip, for customization to any hand, for Vector Infinity 538264

Medium grip, for customization to any hand, for Vector Infinity 538265

Large grip, for customization to any hand, for Vector Infinity 538266

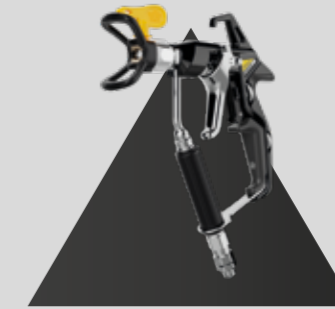

Vector Infinity is - the premium gun

### AIRLESS GUN VECTOR GRIP Art. No.

Vector Grip with G-thread 1/4", incl. TradeTip 3 nozzle holder, 25 MPa (250 bar) with 2- and 4-finger trigger and medium-sized grip 538043

Small grip, for customization to any hand, for Vector Grip 538228

Medium grip, for customization to any hand, for Vector Grip 538229

Large grip, for customization to any hand, for Vector Grip 538230



Vector Grip - fits perfectly in the hand and is suitable for heated applications

### AIRLESS GUN VECTOR PRO Art. No.

Vector Pro with G-thread 1/4", incl. TradeTip 3 nozzle holder, 25 MPa (250 bar) with 4-finger trigger 538040

Vector Pro with G-thread 1/4", incl. TradeTip 3 nozzle holder, 25 MPa (250 bar) with 2-finger trigger 538041

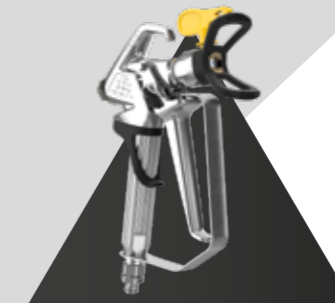

Vector Pro - the entry level spray gun

### AIRLESS GUN AG 14 WITH 4-FINGER TRIGGER Art. No.

Airless gun AG 14, G-thread 1/4", 27 MPa (270 bar), incl. TradeTip 3 nozzle holder 0502081A

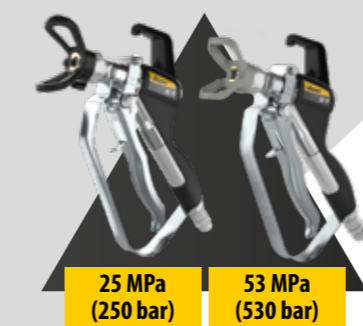

AG 19 - is particularly suitable for highly viscous materials

### FILLER AIRLESS GUN AG 19 WITH 4-FINGER TRIGGER Art. No.

Airless gun AG 19, 25 MPa, G-thread 3/8", incl. TradeTip 3 nozzle holder 2341127

### HIGH-PRESSURE AIRLESS GUN AG 19 WITH 4-FINGER TRIGGER Art. No.

Airless gun AG 19 with G-thread 1/4", 53 MPa (530 bar) 2343778

**HIGH-PRESSURE HOSES** **Art. No.**

DN3, M16 x 1.5, 7.5m	9984584
DN3, NPS (M) 1/4", 7.5 m	9984583
DN3, NPS (M) 1/4", 10 m	2301052
DN4, M16 x 1.5, 7.5 m	9984510
DN4, NPS (M) 1/4", 7.5 m	9984573
DN4, NPS (M) 1/4", 10 m	2302374
DN6, M16 x 1.5, 15 m	9984507
DN6, M16 x 1.5, 30 m	9984562
DN6, NPS (M) 1/4", 15 m	9984574
DN6, NPS (M) 1/4", 30 m	9984575
DN10, PS (M) 3/8", 15 m	2336583*
DN10, PS (M) 3/8", 30 m	2336584*
DN13, NPS (M) 1/2", 15 m	2336585*
DN 19, NPS (M) 3/4", 15 m	2336586*

\* Max. 25 MPa (250 bar)

High-pressure hoses are available in different lengths and inside diameters. The perfect hose for every application

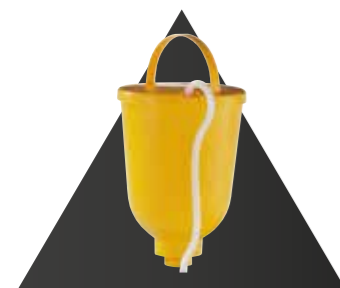
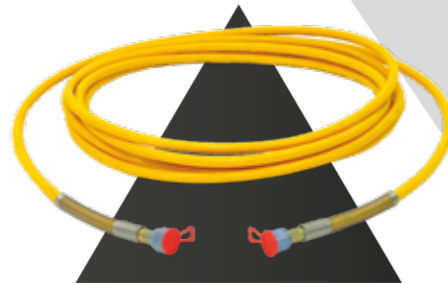

5 litre hopper – perfect for small volumes of paint

**SUCTION SYSTEMS** **Art. No.**

Container suction system, incl. C-coupling adaptor	349907
Reduction adaptor B- to C-coupling	9991651
Blanking plug for C coupling	97305
Container Connector, for HeavyCoat, for direct suction of the material out of the large volume container	2383128
Container Connector, for SF 27/31/33	2371930
Large volume containers (100 l)	2309956
Large volume container, incl. sack support and roller press	2309960
Sack support incl. guide rail for roller, for large volume container	2323178
PumpRunner (only for rigid suction system)	2306987
Suction system, for SF 23 Plus, incl. PumpRunner	2342879

**OTHER** **Art. No.**

Hose reel HR30, M16x1.5, for 30 m HP hose, usable for SF23 Plus / SF 27 / SF 31 (without hose)	341910
Hose reel HR30, 1/4" NPS, for 30 m HP hose, usable for SF 33 (without hose)	2392523
Hose reel HR45, incl. 30 m HP hose DN6, for all diaphragm and piston pumps	341912
Hose whip DN10, max. 25 MPa, NPSM 3/8", 2.5 m	2336582

Hose reel – perfect hose management for optimum handling



**HOPPER** **Art. No.**

Hopper 20 litre, M36x2, for SuperFinish	341266
Hopper 5 litre, M36x2, for SuperFinish	341265
Hopper 5 litre, with TopClean, for SuperFinish	341268
Hopper, 5 litre, for PowerPainter 90 Extra	2423122
Hopper, 5 litre, for ProSpray 3.20, 20, 3.21, 3.25 Skid	704-453



PumpRunner – for clean and easy transportation of the pump

**PAINT ROLLERS** **Art. No.**

Inline Roller IR 100 incl. HP hose DN4, max. 27 MPa, 7.5m, extension 0.5m, woven plush paint roller, short pile 13 mm and much more.	345010
Inner-Feed Roller, 23 cm	2418370
Inner-Feed Roller, incl. extension (0.9 m)	2420499
SprayRoller Frame, 25 cm	2411697
SprayRoller Frame, incl. extension (0.9 m)	2420497
SprayRoller Frame, 23 cm	2418371
SprayRoller Cage, incl. extension (0.9 m)	2420496
Nozzle extension (0.9 m)	2420538

Airless paint roller – consistent coating with paint roller

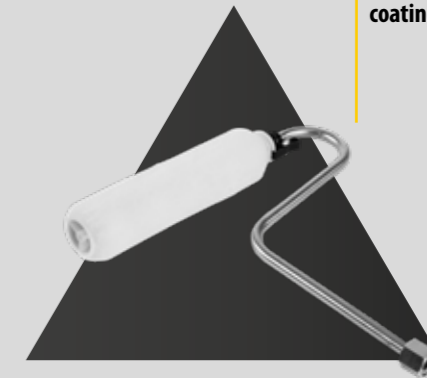

SpeedShield – Trimming cutting in without masking. Delivered without nozzle and extension



**NOZZLE EXTENSIONS** **Art. No.**

Nozzle extension, with holder, without nozzle, 12.5 cm	2418853
Nozzle extension, with holder, without nozzle, 25 cm	2418854
Nozzle extension, with holder, without nozzle, 50 cm	2418855
Nozzle extension, with holder, without nozzle, 75 cm	2418856
Nozzle extension, with holder, without nozzle, 90 cm	2418862
Nozzle extension, with holder, without nozzle, 180 cm	2418863

Nozzle extension – for more comfortable working and a wider reach

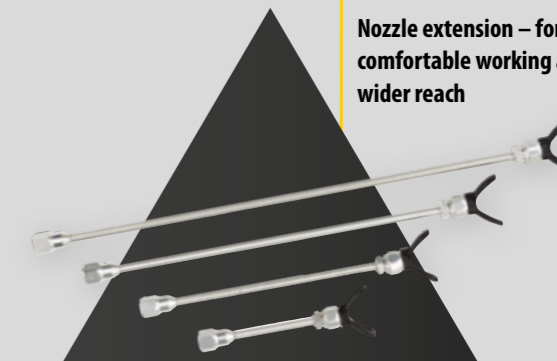

TipClean - easy cleaning and storage of your airless tips



**CLEANING AND STORAGE** **Art. No.**

TipClean, container incl. special cleaner, 200 ml	2400214
EasyClean Cleaning and corrosion protection 1 l	2412656
EasyGlide, special oil, 118 ml	508619

**GUN FILTER** **Art. No.**

Gun filter, red, extra fine, 180 MA, 0.084 mm MW	34383
Gun filter, red, extra fine, 180 MA, 0.084 mm MW, 10 pcs.	97022
Gun filter, yellow, fine, 100 MA, 0.14 mm MW	43235
Gun filter, yellow, fine, 100 MA, 0.14 mm MW, 10 pcs.	97023
Gun filter, white, medium, 50 MA, 0.31 mm MW	34377
Gun filter, white, medium, 50 MA, 0.31 mm MW, 10 pcs.	97024
Gun filter, green, coarse, 30 MA, 0.56 mm MW	89323
Gun filter, green, coarse, 30 MA, 0.56 mm MW, 10 pcs.	97025

Gun filter – avoid nozzle blockages

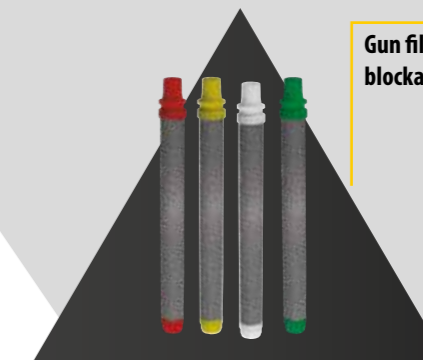



# ACCESSORIES – AIRCOAT for wood and metal craft

Brilliant surfaces with AirCoat: The soft atomization guarantees brilliant surfaces and thus ensures perfect painting results.



## AIRCOAT NOZZLES ACF 3000

The dome-shaped geometry and high-tech honing methods during manufacture ensure extremely fine atomisation with low energy consumption (material pressure). For a long service life and low wear and tear, the nozzle is made from resistant hard metal. The WAGNER AirCoat nozzle ensures brilliant surface finishes: An even spray pattern and extremely gentle graduated borders are guaranteed. This applies to both small and large quantities of atomised air.

Art. No.  
379xxx

Jet width (mm)*	Orifice size (inch)									Spray angle in °
	0.007	0.009	0.011	0.013	0.015	0.017	0.019	0.021	0.023	
55	107		111	113	115					10
100	207	209	211	213	215	217	219	221		20
145	407	309	311	313	315	317	319			30
195		409	411	413	415	417	419	421	423	40
250		509	511	513	515	517	519	521		50
300		609	611	613	615	617	619	621	623	60
400			811	813	815	817	819	821	823	80
Filter	red		red/yellow	yellow	yellow/white	white				



## AIRCOAT PRE-ATOMISATION NOZZLES ACF 3000 PLUS

AirCoat pre-atomisation nozzles provide extra fine atomisation even with low inlet air pressure. This is especially important for processing water- or solvent-based paints. Using a pre-atomisation nozzle allows you to work with less material and air quantity. There is significantly less overspray and material consumption decreases. Compared to the standard AirCoat nozzle the material is pre-atomised directly at the outer edge of the nozzle. The result: an especially even and soft spray pattern.

Art. No.  
321xxx







Jet width (mm)*	Orifice size (inch)								Spray angle in °
	0.008	0.010	0.012	0.014	0.016	0.018	0.020	0.022	
100	208	210	212	214	216	218			20
145	308	310	312	314	316	318	320		30
195	408	410	412	414	416	418	420	422	40
250	508	510	512	514	516	518			50
300		610	612	614	616	618	620	622	60
Filter	red		red/yellow	yellow	yellow/white	white			

\* Spray width (mm) at approx. 30 cm distance from the object and 10 MPa (100 bar) pressure, with synthetic resin paint, 20 DIN seconds

\*\* Measured with water at 12 MPa (120 bar) pressure

## AIRCOAT MATERIALS

Only for AirCoat nozzles,  
ACF 3000 & ACF 3000 Plus

	Water and solvent-based lacquers, lacquer paints, oils, separating agents		Synthetic resin lacquers, PVC lacquers, 2K lacquers		Primers, fillers
	Fillers, rust protection paints		Fire protection, rust protection paints		Corrosion protection

### AIRCOAT GUN AC 4500 Art. No.

AirCoat gun AC 4500, incl. blue air cap and holder	2368269
AirCoat gun AC 4500, incl. green air cap and holder	2368270
AirCoat gun AC 4500, incl. red air cap and holder	2368271

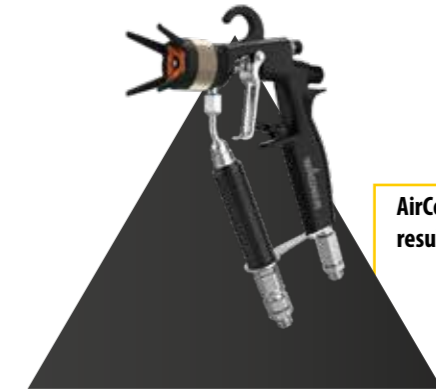

**AirCoat AC 4500 for perfect surface results**

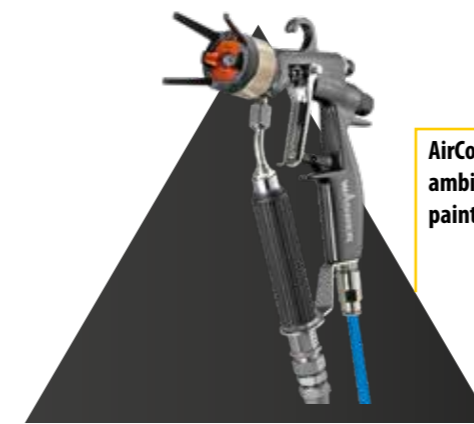

**AirCoat AC 4600 for ambitious, comfortable painting work**

### AIRCOAT PISTOLE AC 4600 Art. No.

AC 4600 Professional, incl. blue air cap and holder	394156
AC 4600 Professional, incl. green air cap and holder	394158
AC 4600 Professional, incl. red air cap and holder	394157

### AIRCOAT GUN ACCESSORIES Art. No.

Air cap blue, for water-based materials (01)	394911
Air cap red, for solvent-based materials (02)	394910
Air cap green, for water-based materials and solvent-based materials (03)	394912
Union nut, complete (04)	394921

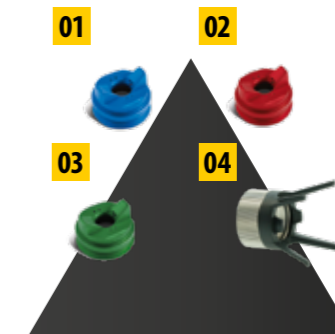

**Various air caps for different applications**

## ACCESSORIES – PLASTCOAT

### CONTINUOUS MIXER

	Art. No.
PlastMix 15, with steel mixing tube	2348669
PlastMix 15, with PUR mixing tube	2359240



Continuous mixer for dry materials



PlastGuard longlasting - to protect the device and for optimum storage

### ACCESSORIES FOR PLASTCOAT HP 30

	Art. No.
PlastGuard longlasting pump protector, 5 l	2399960
PlastCoat HP 30 emulsion set	2400684

### CLEANING AND STORAGE

	Art. No.
Brush with handle and cap	9100095
Bottle brush for cleaning interior of outlet unit and spraying lance	342329
Cleaning adapter M27GK	342241
Cleaning brush, 280 to 420 mm long	348959
Cleaning ball DN16	2402355
Cleaning ball DN19	342330

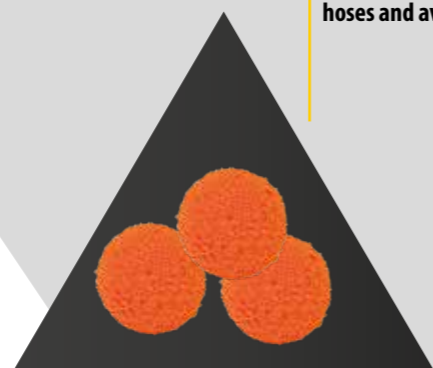

Cleaning balls – for cleaning out hoses and avoiding nozzle blockages

Bag processing table – for the convenient emptying of bagged goods

### SUPPORT TABLE INCL. ROLLER PRESS

	Art. No.
Support table, for PC 830	2318389
Support table, for PC HP 30	2389048



Current prices and further information about our products can be found here:  
[go.wagner-group.com/produkte](https://go.wagner-group.com/produkte)

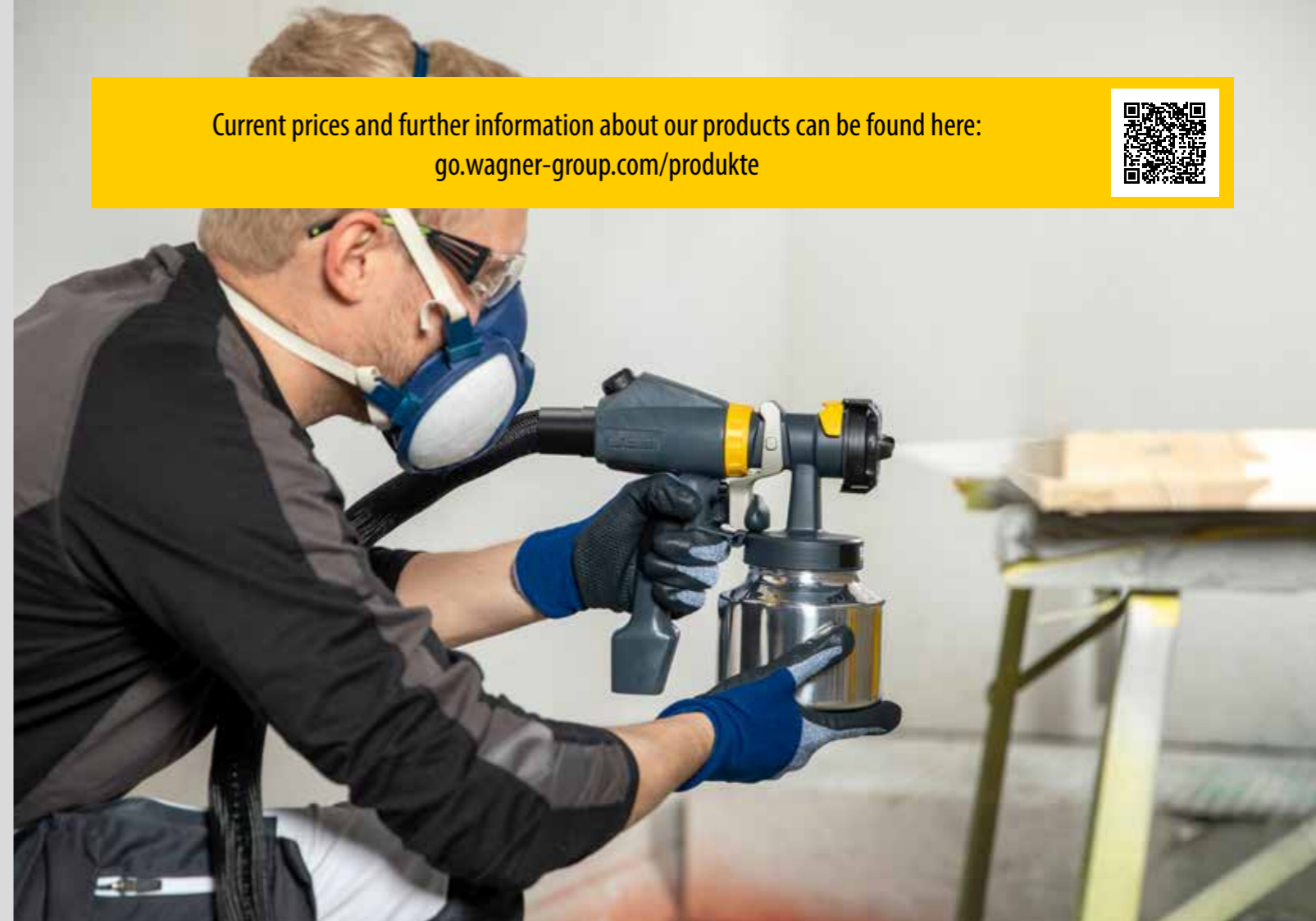

Contents, prices and specifications of 01/2023. All specifications are subject to change. Reproduction is prohibited without the consent of J. Wagner GmbH. Current general terms and conditions of the WAGNER-Group can be found on [www.wagner-group.com](http://www.wagner-group.com).

# BE UNSTOPPABLE!

**VISIT US AT**

