

FE-185-5-5350-000-C1330

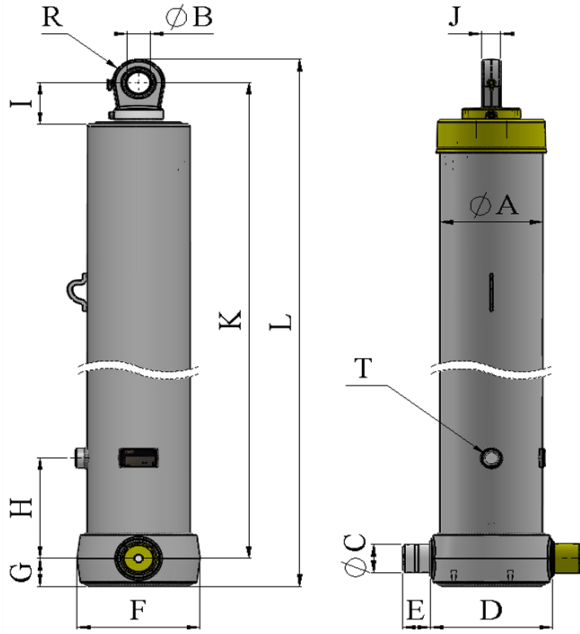

ACCESSORIES (Optional)

BODY BRACKET KBR-02

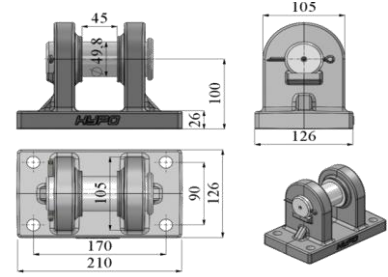

CHASSIS BRACKET SBR-02

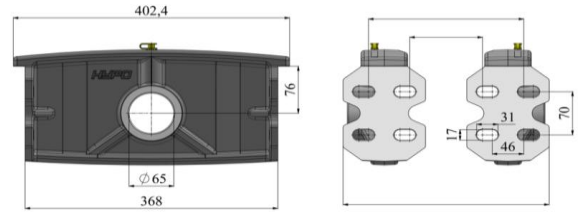

UNITS TABLE (mm)

A :	218	I :	100
B :	50	J :	40
C :	65	K :	1330
D :	260	L :	1450
E :	58	M :	N/A
F :	255	N :	N/A
G :	65	R :	55
H :	235	T :	G 1"

TECH. SPECIFICATIONS

Max. Pressure :	190 bar
Cylinder Weight (Kg) :	296
Total Oil Volume (Lt) :	97
Closed Length (mm) :	1330
Opened Length (mm) :	6680
Total Stroke (mm) :	5350
Oil Inlet :	G 1"



PULL OUT

When mounting the cylinder, the inner stage is mounted by opening +30 mm.

Stages	1	2	3	4	5	6	7	8	9	10	TOTAL
Stage Diameter (Ø)	185	160	135	115	95						
Stroke (mm)	1070	1070	1070	1070	1070						5350
Max. Thrust (Ton)	51,0	38,2	27,2	19,7	13,5						



USING INSTRUCTION

This cylinder is used only as a lifting device. This cylinder is designed for longitudinal loads. It should not be used in a horizontal position. The cylinder should not be used as any supporting structural device. The operating temperature range of the hydraulic oil should be selected between -40°C and +80°C.



CYLINDER INFORMATION

The cylinders are produced in standard RAL 9005 coded black paint and the minimum thickness has been subjected to ISO 9227 natural salt spray test for 480 hours. All stages are 20 µm hard chromed. The trunnions are made of cast steel or forged steel. Cylinder heads are made of forged steel. All stages are manufactured from seamless cold drawn S355J0 quality material.



SAFETY RULES

Do not operate above the permissible working pressure and load capacity. Adjust the safety valve only to the permissible working pressure. Pay attention to the characteristics of the hydraulic oil used in the cylinder and use a filter. Do not load over capacity and unbalanced load on the vehicle.

NOTES

Old Code: FE-5650-1215-5

REVISIONS

Please contact our Technical Dep. For your other questions

Technical Calculations

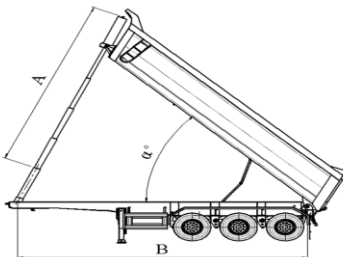

$$\alpha^\circ = \frac{Ax60}{B} \quad F (N) = 10 \times C (cm^2) \times P (bar)$$

α° :	Body Angle (°)	F :	Thrust (Newton)
A :	Stroke (mm)	C :	Area (cm ²)
B :	Pivot Length (mm)	P :	Pressure (bar)

$$10 N \approx 1 Kg$$

BODY ANGLE (α°)

α°	40	45	50	55	60
STROKE (A)	5350				
PIVOT L. (B)	8025	7133	6420	5836	5350