



SFP-ONU-GPON Transceiver module

1.25Gb Tx/2.5Gb Rx ONU with MAC

LIGHTX

General Description

The series transceiver is a high performance module for single fiber communications using a 1310nm burst-mode transmitter and a 1490nm continuous-mode receiver. It is used in the optical network terminal (ONT) for GPON ONU Class B+ applications with Mac inside.

The Transmitter is designed for single mode fiber and operates at a nominal wavelength of 1310nm. The transmitter module uses a DFB laser diode with full IEC825 and CDRH class 1 eye safety.

The receiver section uses a hermetic packaged APD-TIA (APD with trans-impedance amplifier) and a limiting amplifier. The APD converts optical power into electrical current and the current is transformed to voltage by the trans-impedance amplifier. The differential DATA and /DATA CML data signals are produced by the limiting amplifier.

An enhanced Digital Diagnostic Monitoring Interface has been incorporated into the transceivers. It allows real time access to the transceiver operating parameters such as transceiver temperature, laser bias current, burst mode transmitted optical power, received optical power and transceiver supply voltage by reading a built-in memory with I2C interface.

Standard

- Complies with SFP Multi-Source Agreement (MSA) SFF-8074i
- Complies with ITUT-T G.984.2, G.984.2 Amendment 1
- Complies with ITUT G.988 ONU management and control interface (OMCI) specification
- Complies with SFF 8472 V9.5
- Complies with FCC 47 CFR Part 15, Class B
- Complies with FDA 21 CFR 1040.10 and 1040.11

Product Features

- Single fiber bi-directional data links asymmetric TX 1244Mbps / RX 2488Mbps GPON ONU application with GPON MAC function
- SC/UPC or SC/APC receptacle SFP with GPON ONU MAC inside, "Plug-and-play" via auto-discovery and configuration
- 1310nm DFB burst mode transmitter, 1490nm APD-TIA continuous mode receiver for 20km transmission
- 0 to 70°C operating case temperature for C-Temp
- -40 to 85°C operating case temperature for I -Temp
- Single 3.3V power supply
- Digital diagnostic monitor interface compatible with SFF-8472
- SFP MSA compliance
- Low EMI and excellent ESD protection
- Class I laser safety standard IEC-60825 compliant
- RoHS-6 compliance

Applications

- Gigabit-capable Passive Optical Networks (GPON)
- This transceiver is a MSA-compliant SFP that incorporates not just the optics for an ONU, but all of the electronics need as well. It is a "PON on a Stick" that an entire FTTH ONU in a slightly oversized SFP. It can be plugged into networking equipment. Allowing the data interfaces on a switch, router, PBX, etc. to be customized for different fiber environments and distance requirements
- The transceiver is designed as dual-mode ONU stick, it also supports the EPON ONU OAM. It can be applied both on EPON system and on the GPON system .It will automatically establish an EPON link with the EPON OLT or GPON link with the GPON OLT.



SFP-ONU-GPON Transceiver module

1.25Gb Tx/2.5Gb Rx ONU with MAC

Ordering Information

Part No.	Product Specification				
	Package	Data-Rate	Temperature	RoHS	Application
SFP-ONU-GPON	SFP, SC/UPC	1.244Gb/s/2.488Gb/s	0°C ~70°C	RoHS 6	GPON Class B+, MAC inside
ISFP-ONU-GPON	SFP, SC/UPC	1.244Gb/s/2.488Gb/s	-40°C ~85°C	RoHS 6	GPON Class B+, MAC inside
SFP-ONU-GPON-A	SFP, SC/APC	1.244Gb/s/2.488Gb/s	0°C ~70°C	RoHS 6	GPON Class B+, MAC inside
ISFP-ONU-GPON-A	SFP, SC/APC	1.244Gb/s/2.488Gb/s	-40°C ~85°C	RoHS 6	GPON Class B+, MAC inside

Absolute Maximum Ratings

Parameters	Symbol	Min	Max	Unit	Note
Storage Ambient Temperature	T _{STG}	-40	85	°C	
Operating Case Temperature	T _c	0	70	°C	C-Temp
		-40	85	°C	I -Temp
Operating Humidity	OH	5	95	%	
Power Supply Voltage	V _{CC}	0	3.63	V	
Receiver Damaged Threshold		+4		dBm	
Soldering Temperature			260/10	°C/S	

Recommended Operating Conditions

Parameters	Symbol	Min	Typical	Max	Unit	Note
Power Supply Voltage	V _{CC}	3.13	3.3	3.47	V	3.3V±5%
Power Dissipation	PD		2.00	2.48	W	
Operating Case Temperature	T _c	0		70	°C	C-Temp
		-40		85	°C	I -Temp
Operating Humidity Range	OH	5		85	%	
Data Rate upstream			1.244		Gbit/s	
Data Rate downstream			2.488		Gbit/s	
Data Rate Drift		-100		+100	PPM	

Transmitter Optical and Electrical Characteristics

Parameter	Symbol	Minimum	Typical	Maxim	Unit	Note
Optical Center Wavelength	λ _C	1290		1330	nm	
Side Mode Suppression Ratio	SMSR	30			dB	

Optical Spectrum Width	$\Delta\lambda$			1	nm	
Average Launch Optical Power	P_o	+0.5		+5	dBm	1
Power-OFF Transmitter Optical Power	P_{off}			-45	dBm	
Extinction Ratio	ER	9			dB	2
Rise/Fall Time (20%-80%)	TR/TF			260	ps	2,3
Turn On Time at Burst mode	T_{on}			12.8	ns	
Turn Off Time at Burst mode	T_{off}			12.8	ns	
RIN15OMA				-115	dB/Hz	
Optical Return Loss Tolerance				15	dB	
Transmitter Reflectance				-6	dB	
Transmitter and Dispersion Penalty	TDP			2	dB	4
Optical Waveform Diagram	Compliant With ITU-T G.984.2					
Data Input Differential Swing		300		1600	mV	6
Input Differential Impedance		90	100	110	Ω	
Tx-Disable Voltage (Enable)		0		0.8	V	
Tx-Disable Voltage (Disable)		2.0		VCC	V	
Tx-Fault Output (Normal)		0		0.8	V	
Tx-Fault Output (Fault)		2.0		VCC	V	

Notes:

1. Launched into 9/125um Single Mode Fiber.
2. Measured with PRBS 2²³-1 test pattern @1.244Gbit/s.
3. Measured with the Bessel-Thompson filter OFF.
4. Maximum sensitivity penalty due to transmitter and dispersion effect through 20km of SMF optical fiber.
5. Transmitter eye mask definitions (Figure 1).
6. Compatible with LVPECL input, DC coupled internally.

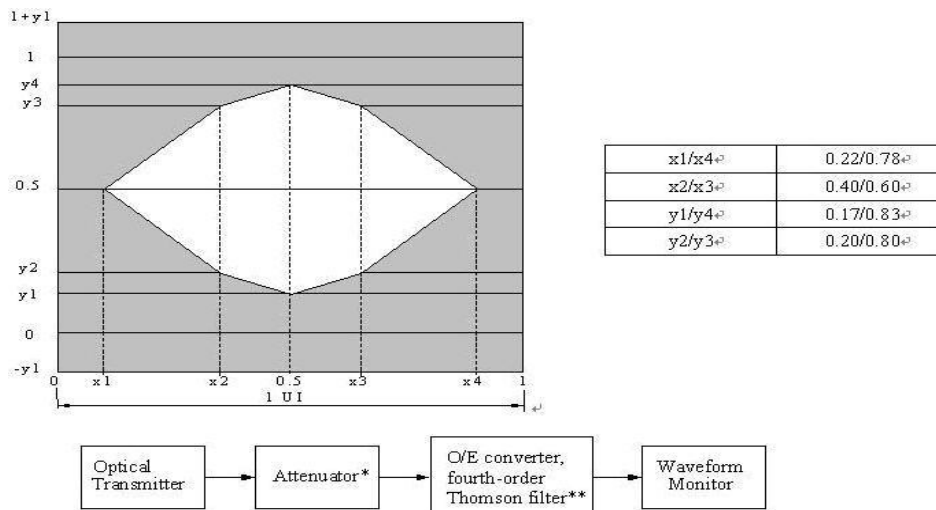

*: Attenuator is used if necessary.

** : Cut-off frequency (3 dB attenuation frequency) of the filter is 0.75 times output nominal bit rate.

Figure 1: Transmitter Eye Mask Definitions

Receiver Optical and Electrical Characteristics

Parameters	Symbol	Min	Typical	Max	Unit	Note
Operating Wavelength		1480	1490	1500	nm	
Sensitivity	SEN			-28	dBm	1
Saturation Optical Power	SAT	-8			dBm	
LOS Deassert Level				-29	dBm	2
LOS Assert Level		-40			dBm	
LOS Hysteresis		0.5		5	dB	
Receiver Reflectance				-20	dB	
WDM Filter Isolation		38			dB	1550nm
		35			dB	1650nm
Data Output Differential Swing		300		1200	mV	3
LOS low voltage		0		0.8	V	
LOS high voltage		2.0		VCC	V	

Notes:

1. Measured with a PRBS $2^{23}-1$ test pattern @2.488Gbit/s and ER=9dB, BER = 10^{-12} .
2. A decrease in optical power above the specified level will cause Los output to switch from a low state to a high state; An increase in optical power below the specified level will cause Los output to switch from a high state to a low state.
3. CML output, AC coupled internally, guaranteed in the full range of input optical power (-8dBm to -28dBm).

SFP-ONU-GPON Transceiver module

1.25Gb Tx/2.5Gb Rx ONU with MAC

EEPROM Information

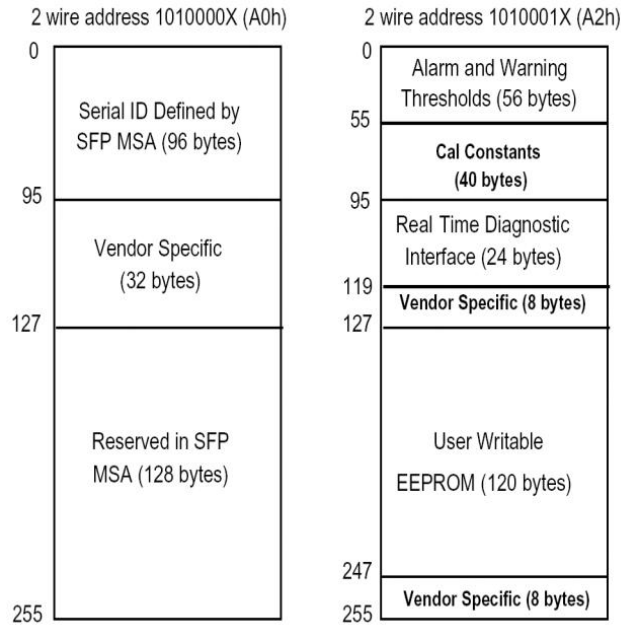

Figure 2:EEPROM Information

Pin Out Drawing

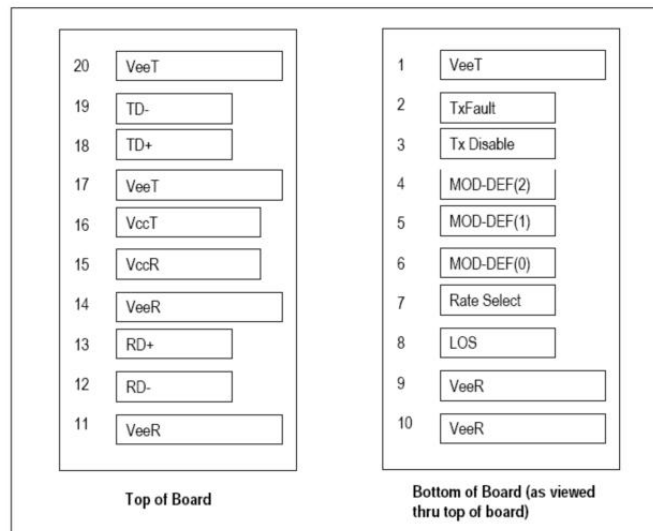

Figure 3:Pin Out Drawing (Top view)

Pin Description

PIN	Name	Description	Notes
1	VeeT	Transmitter Ground	1
2	Tx-Fault	Transmitter Fault Indication ,Normal "0", fault: Logic "1"output , LVTTTL	2
3	Tx-Disable	Transmitter Disable; turns off transmitter laser output	3



SFP-ONU-GPON Transceiver module

1.25Gb Tx/2.5Gb Rx ONU with MAC

PIN	Name	Description	Notes
4	Mod-Def(2)	SDA I2C Data line	2
5	Mod-Def(1)	SCL I2C Clock line	2
6	Mod-Def(0)	Module Absent, connected to VeeR	2
7	Rate Select	For Dying Gasp detect, input low active	
8	LOS	Loss of Signal	2
9	VeeR	Receiver Ground	1
10	VeeR	Receiver Ground	1
11	VeeR	Receiver Ground	1
12	RD-	Inv. Received Data Output	
13	RD+	Received Data Output	
14	VeeR	Receiver Ground	1
15	VccR	Receiver Power	1
16	VccT	Transmitter Power	
17	VeeT	Transmitter Ground	1
18	TD+	Transmit Data In	
19	TD-	Inv. Transmit Data In	
20	VeeT	Transmitter Ground	1

- Notes:
1. Module circuit ground is isolated from module chassis ground within the module.
 2. The pins shall be pulled up with 4.7K-10KΩ to a voltage between 3.13V and 3.47V on host board.
 3. The pin is pulled up to VccT with a 4.7K-10KΩ resistor in the module.

Recommended Board Layout

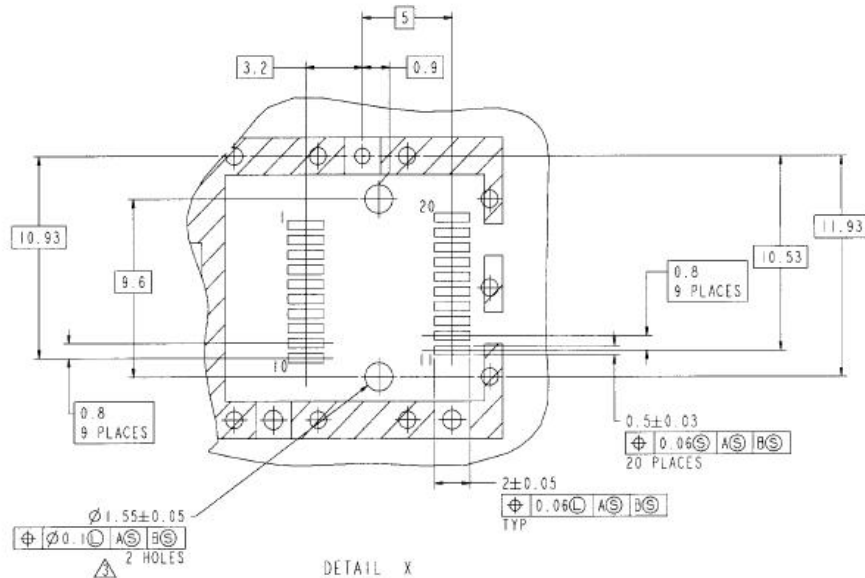

SFP-ONU-GPON Transceiver module 1.25Gb Tx/2.5Gb Rx ONU with MAC

- Notes:**
1. Datum and basic dimensions established by customer
 2. Pads and vias are chassis ground, 11 places
 3. Thru holes, plating optional

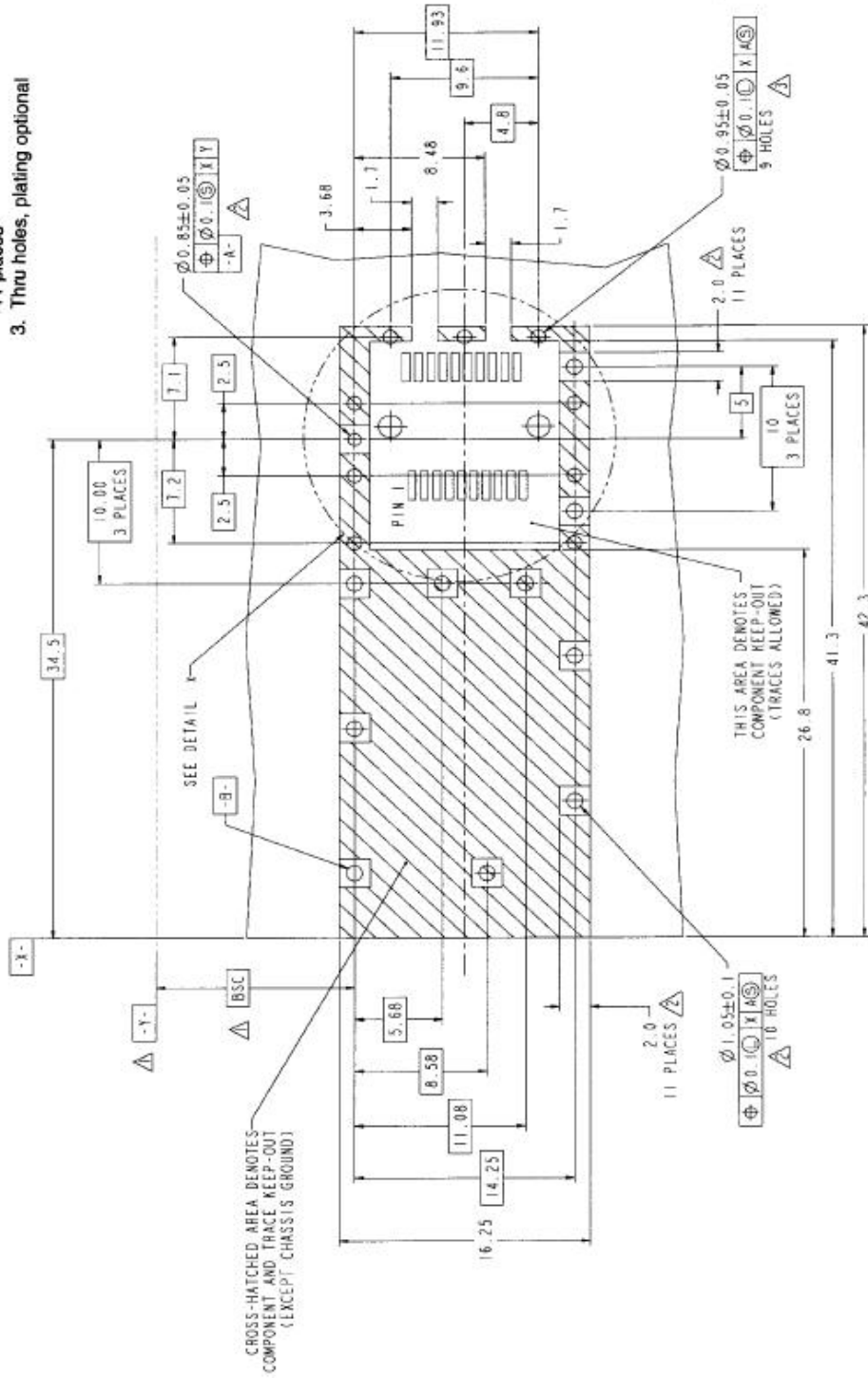

Figure 4: Recommended Board Layout Hole Pattern and Panel Mounting

SFP-ONU-GPON Transceiver module 1.25Gb Tx/2.5Gb Rx ONU with MAC

Mechanical Dimensions

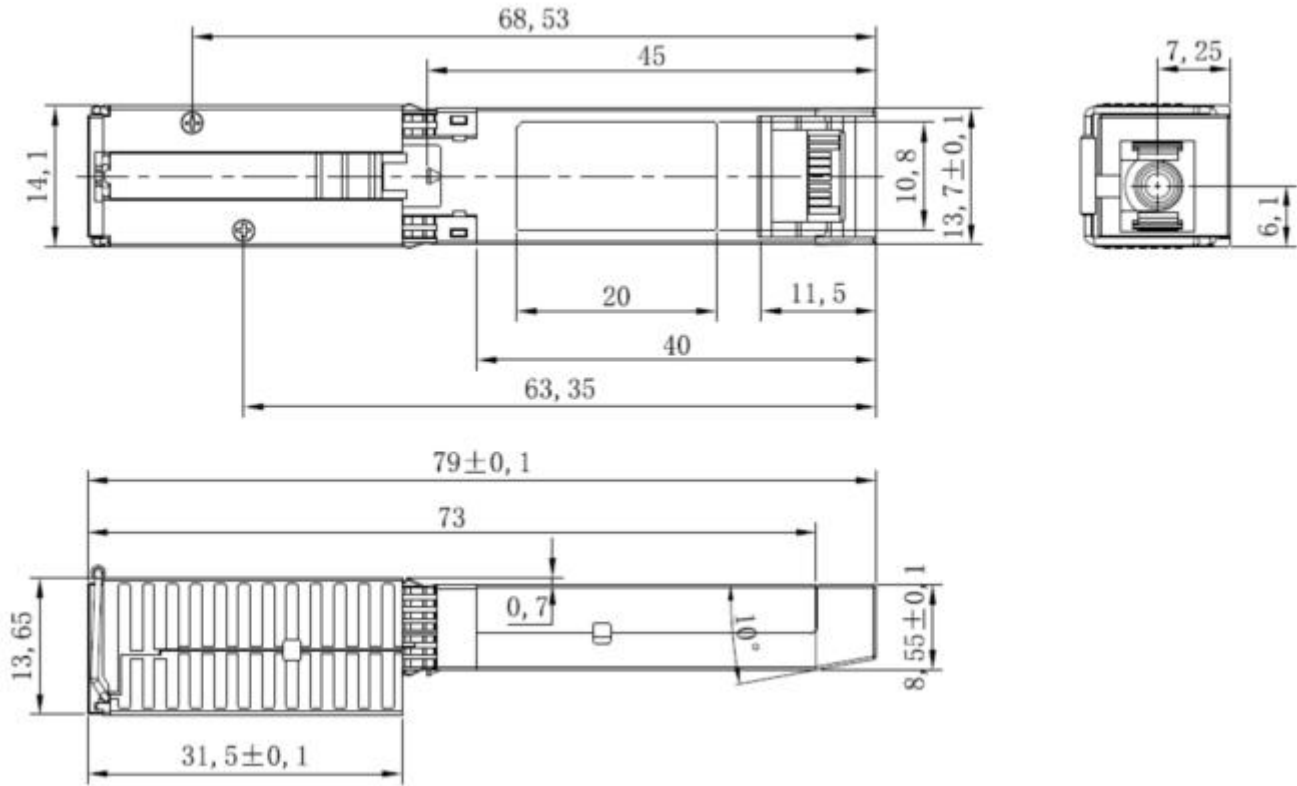

Figure 5: Package Outline (unit: mm)