



**RIGHT TO DEFENSE**

**USER MANUAL**

**BLACK STORM**  
**MERLIN**  
**PROFESSIONAL BS-5**

## **Tactical conversion kit pre-equipment for Carbines / automatic guns of the AK according to the scheme "Bullpup"**

### *Description, characteristics, images.*

Conversion kit, which simplifies the combat in limited conditions. The kit is created according to the Bullpup scheme. Bullpup kit is designed for installation on carbines model of AK series: AK-47, AKM, AKMS-MF, AK-74, AKS-74 (except AKS-74U).

The kit is intended for modernization and increase of tactical and technical characteristics of carbines / automatic guns without invading the weapon design. Installing the Bullpup kit on a weapon turns an AK on a modern, competitive assault rifle, with all advantages of TTC Kalashnikov's automatic gun.

*It is important that the weapon is just as easy  
to bring to its original state.*



It is structurally ergonomic for use in extraordinary situations, on hunting and, most importantly, **in battle.**

**BLACK STORM**  
**MERLIN**

**2**

## ***Bullpup performs the following main tactical functions:***

1. Transforms old, tactically obsolete weapons to the level of modern ones.
2. Frees up the other hand and provides advantages in maneuverability.
3. Allows you to quickly intercept the weapon in the opposite hand.
4. Allows you to conveniently fire from around the corner.
5. To move with a weapon with the standard fuse removed.
6. Disguise the weapon by painting the Bullpup in camouflage colors, wrap with masking material, stick tapes, etc. according to tactical tasks.
7. Significantly hide the heated barrel from the enemy's thermal imagers.
8. Provides new functions:
  - convenient reloading on the left side of the weapon
  - mechanism of emergency store reset
  - additional fuse on the fire control handle
  - retractable mechanical sights (front sight + rear sight)
  - a picatinny bar at an angle of 45 degrees on the right side
  - vertically adjustable (up-down) occiput of the butt

The kit is easily mounted on the weapon with one screw.

After setting up (shooting) aiming devices

Your assault rifle is ready to go.

*It is forbidden to install the retrofit kit on a loaded weapon.*

### **Fuse.**

To prevent accidental discharge (uncontrolled shot) use the weapon's stock safety.

### **Shutter frame.**

When working with the left hand, be careful, keep the safe onedistance from the shutter frame hook (maximum movement of the shutter).

The Bullpup kit is made of: 1mm steel, polymer and rubber.

Weight of the **BS-5** kit: 1940 g. Weight AKM - 2320 g, AKS - 2360 g.

Complete with AKM 47 carbine (without magazine): 4360 g.

Complete with AKS 74 carbine (without magazine): 4400 g.

Maximum overall dimensions along the barrel section (without magazine):

Length 725 mm, width 95 mm, height 225 mm

**BLACK STORM**  
**MERLIN**



# THE INSTRUCTIONS FOR INSTALLATION

## **BLACK STORM** **MERLIN**

To install on the carbines / automatic guns of AK series:  
AK-47, AKM, AKMS-MF, AK-74, AKS-74  
(except AKS-74U)

### 1. Completeness of the product:

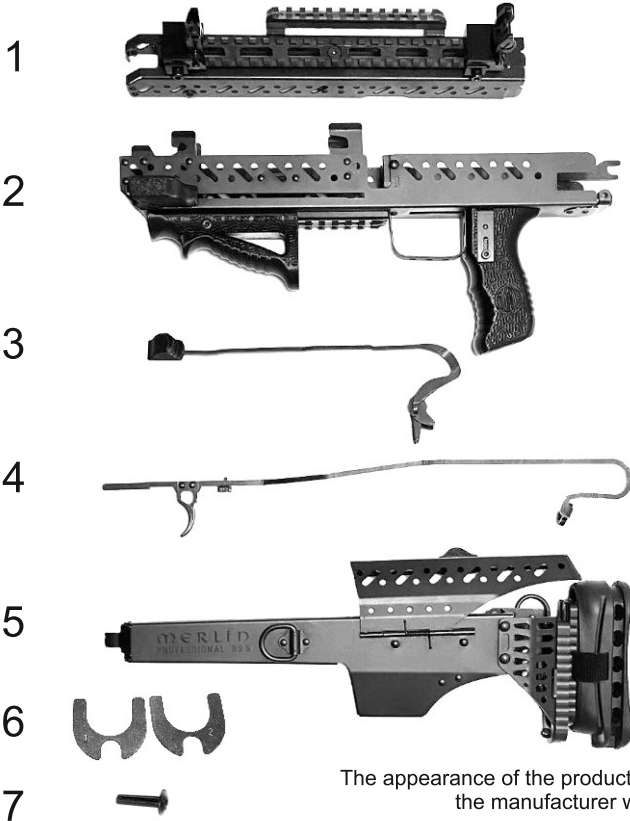

The appearance of the product may change by the manufacturer without warning.

## **BLACK STORM** **MERLIN**



**WARNING!** Before starting to install the kit on a carbine/machine gun, be sure to make sure that the weapon is discharged and there is no cartridge left in the barrel. Installation of the modernization kit on a loaded weapon is dangerous for your life and can injure others.

## 2. Factory-made carbine/machine gun.



3. Disassemble the carbine/machine gun by removing the ramrod, butt, cover of the gas outlet tube, stock, control handle and its screw (the screw is used during assembly).  
Weight AKM - 2320 g, AKS - 2360 g.



**BLACK STORM**  
**MERLIN**

**5**

**4a.**

Dismantling the lining of the gas outlet tube.  
Holding the rearcoupling, rotate the pad 180 degrees.

**4b.**

After turning, remove it from the gas outlet tube, lowering it down.

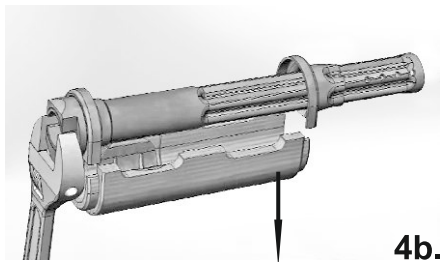
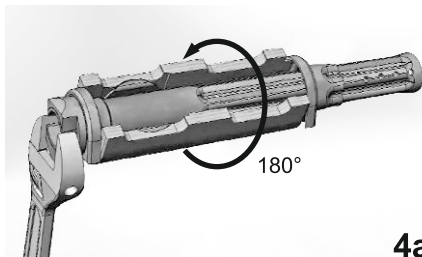

**5.** Depending on the model and modification of the weapon, it is mandatory a calibration insert of 1.0 mm or 1.2 mm is installed (on salidol, lithol, etc.).  
It is checked by tightly closing the flag of the tweezer bracket.

**WARNING!** When assembling a set of any gaps between body kit and weapons should not be.

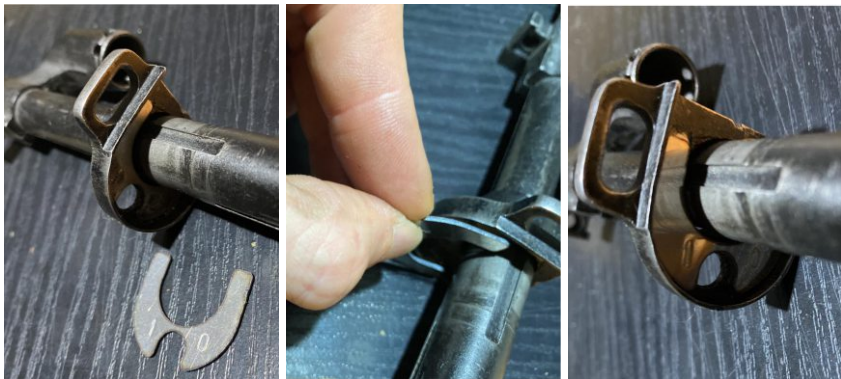

**BLACK STORM**  
**MERLIN**

**6**

6. Install the fire control rod on the carbine/machine gunin such a way that its rounded side is worn on the regular onetrigger, and insert its sharp end into the hole under the ramrod,in the lower part of the ring of the thread (diagram).Important: do not under any circumstances deform the fire control rod- it may damage its functions.

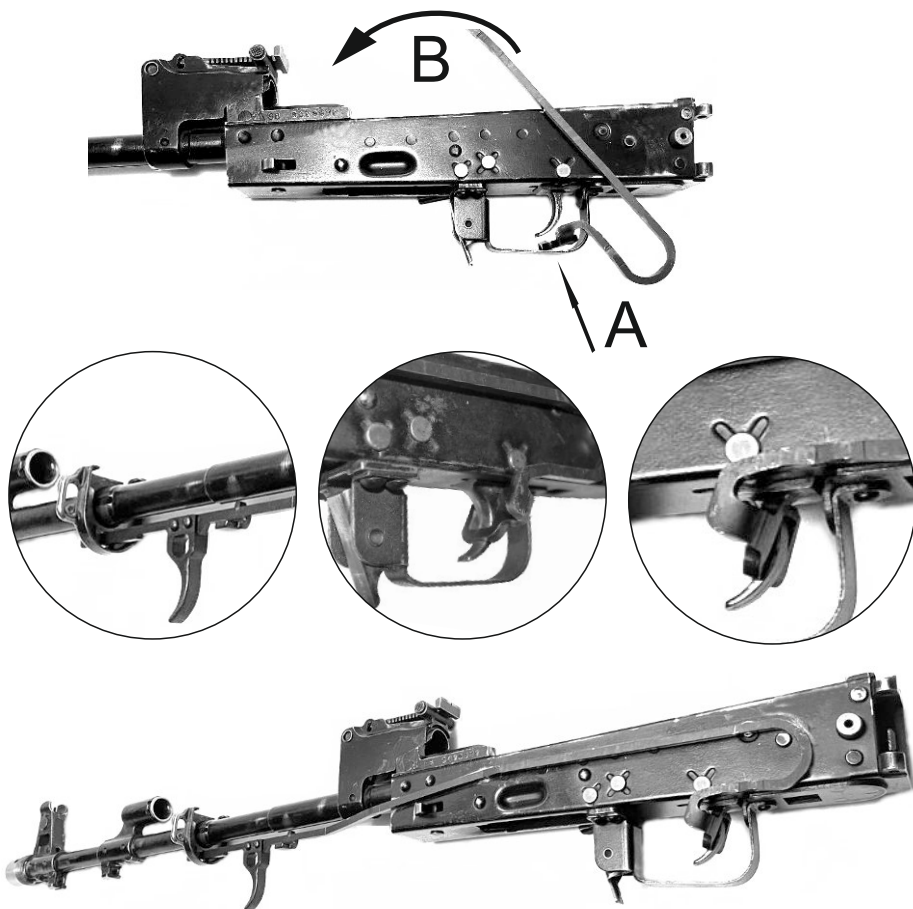

**BLACK STORM**  
**MERLIN**



7. Push the fuse down (open / removed). Install the forend in the receiver on the side of the barrel under the sightpad (diagram). Make sure the thread is firmly seated in the receiver and there are no gaps left between them. Fix the forend with a ring and close the flag on the forend ring.

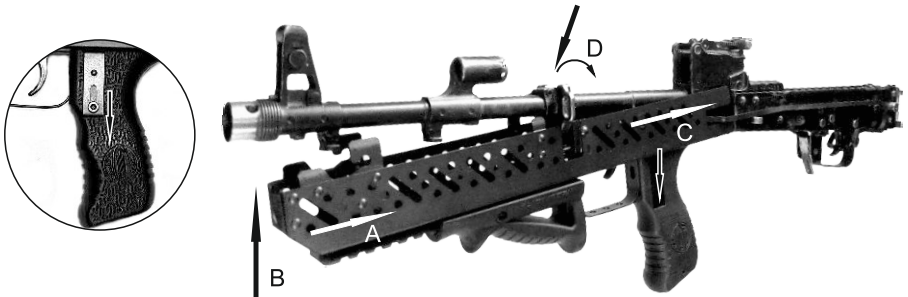

8. Install and fix the gas outlet tube.



9. Install the magazine emergency reset mechanism. Tilt towards the barrel. Secure tightly with 2 dowels.



**BLACK STORM**  
**MERLIN**



**10.** Install the butt-but, winding it above the upper onesrivets of the receiver, until its lower partthe body will not touch the fire control rod. After thisturn the breech stock at a 45 degree angle to the weapon andput the stock body on the pull, then align the stockparallel to the receiver.

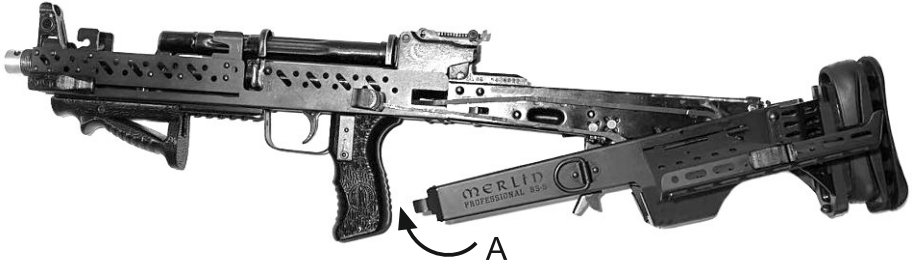

**11.** Put the butt all the way to the side of the barrel - press on trigger. Engage the butt lock with the slotthe lids of the hopper.

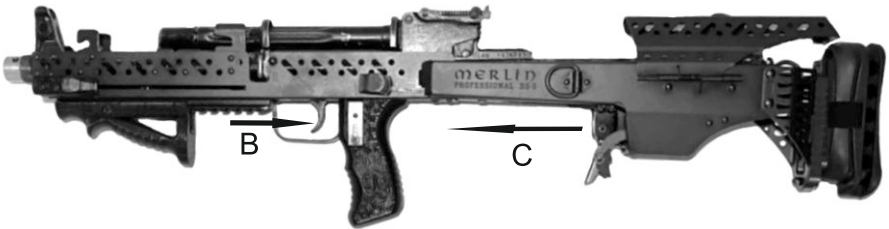

**11 a.** Install the standard gun mounting nuthandles.

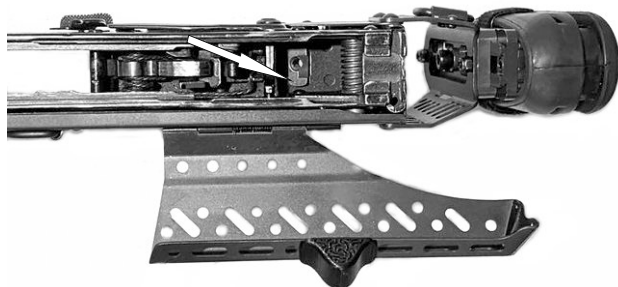

**BLACK STORM**  
**MERLIN**

**11 b.** Holding the pistol grip nut, fix the stock with a screw.

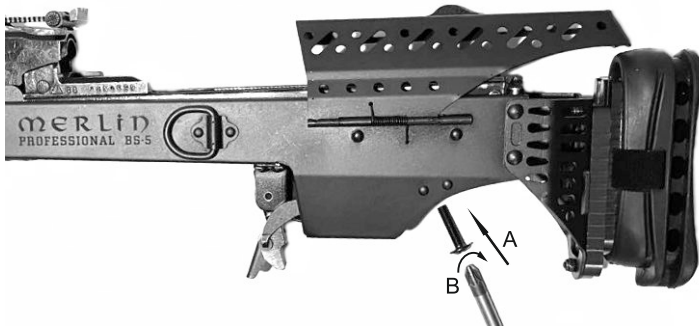

**12.** Take the cover of the fuse. Select the checkbox to the back (open) position. Install the cover on the spout so that it adjoins the plane of the thread along its entire length. Fasten the cover on the bracket of the lock with a movement in the direction of the sightboxes to the stop. Lock the cover by turning the flag clockwise (diagram).

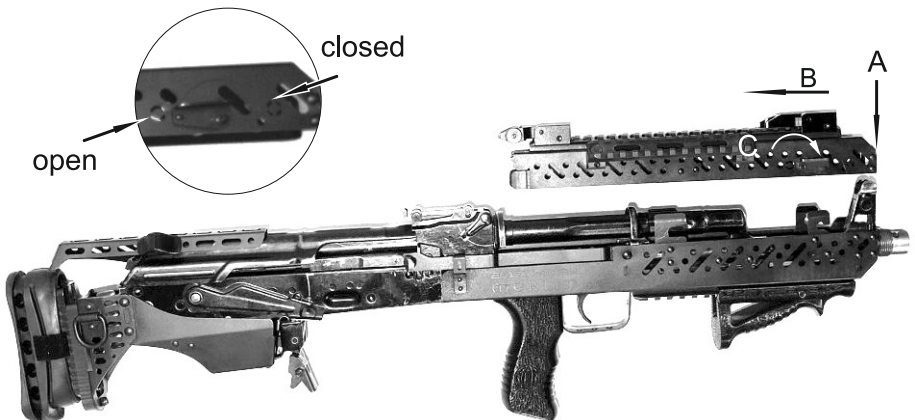

**13.** Install the bolt, spring and close the coverreceiver.  
Be sure to check for accuracy assembly and performance  
of the device in an uncharged state condition.



**14.** The assault rifle is ready for use.



***Disassembly of the kit is carried out in the reverse order.***

1. Bullpup tactical fairing is removed.
2. A standard sample is installed.
3. The standard fuse is installed.
4. A regular pistol grip is installed.
5. A gas outlet pipe with a standard cover is installed.

The carbine/machine gun is in standard condition.





Attention! This product is protected by Ukrainian and International copyright laws.  
All rights to this set and production is owned by the patent holder.  
Reproduction of the kit, parts thereof is prohibited or their appearance  
(form) without the official consent of the author.

Patent № 98125 22.04.2015

Patent № 31130 25.12.2015

**[HTTP://BLACKSTORM.COM.UA](http://BLACKSTORM.COM.UA)**