

# Electromagnetic Flow Monitor *magphant*



## Monitoring and measurement

- Flow monitoring with selectable limit values (relay output)
- Flow measurement via 4...20 mA current output

## Safe operation

- Reliable monitoring (4 mA) even with empty piping
- EMC tested according to IEC
- Measuring system self-monitoring
- Integrated testing to check correct functioning of the electronics

## Universal application

- One compact flow monitor for all applications
- Mounted in
  - Steel piping from DN 25
  - Plastic piping from DN 15

## Simple operation

- Switchpoint setting via rotary switch
- Local potentiometer setting of full-scale value
- Can be set-up before installation

Endress + Hauser

Nothing beats know-how



# Magphant Measuring System

## Areas of application

Flow information is often required to ensure a process is running correctly and that preset limit values are not exceeded. The Magphant flow monitor reliably provides the necessary informa-

tion on flow in your piping. The electromagnetic principle used determines the flow velocity of the conductive liquid at the tip of the sensor.

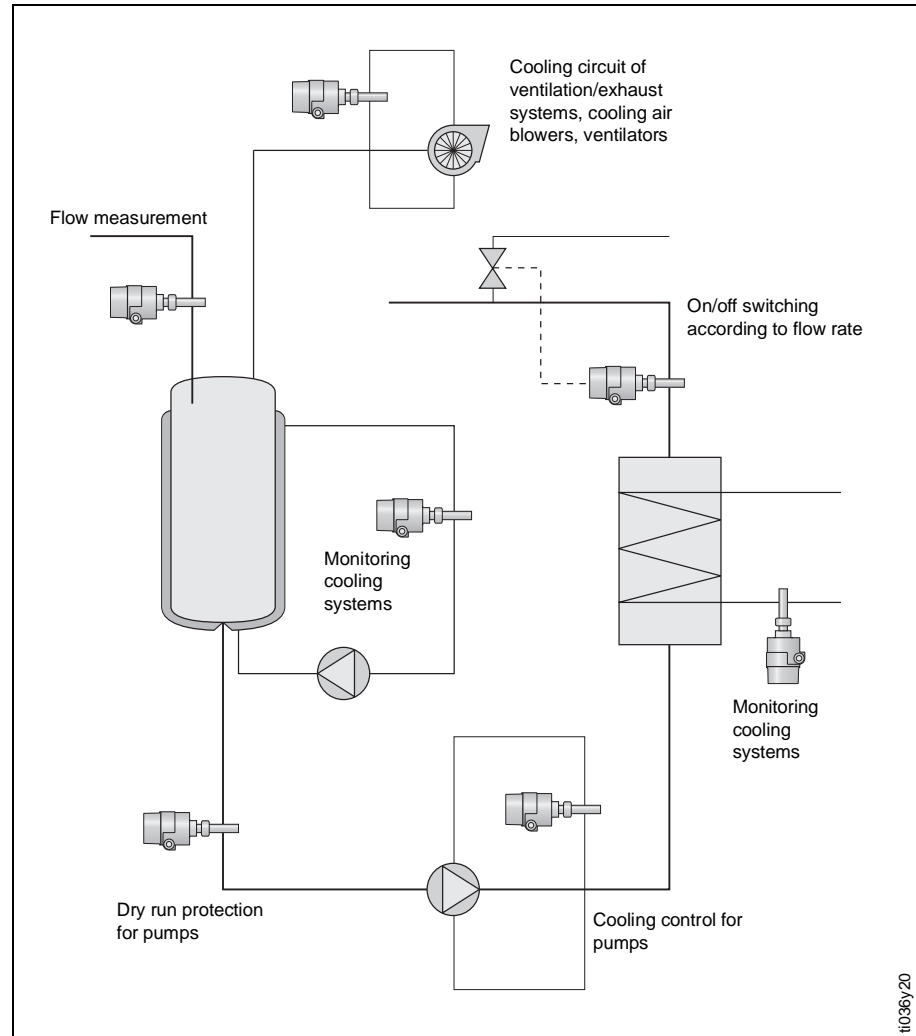

Application examples

## Areas of application:

- Process plant construction
- Chemical industry
- Energy production
- Water treatment
- Beverage industry
- Dairy industry
- Metal production and processing
- Farming and horticulture

## Applications:

- Dry run protection for pumps
- Flow monitoring
- On/off switching according to flowrate
- Control of cooling systems for pumps, turbines, compressors, heat exchangers
- Flow monitoring
- Monitoring pump function
- Monitoring coolant to bearings for turbines/generators in power plants
- Cooling circuits for transformers
- Status indication of valves in water distribution systems
- Blockage indication in pipes
- Filtration control
- Monitoring cleaning procedures
- Cooling systems in refrigeration plants
- Detecting breakdown of cooling systems for bearings and transmissions
- Control and monitoring of irrigation systems

# Function

## Measuring principle

In accordance with Faraday's law of electromagnetic induction, a voltage is induced in a conductor that is moved through a magnetic field. In the electromagnetic principle of measurement the flowing and electrically conductive fluid represents the moving conductor. The

induced voltage is proportional to the flow velocity and is fed to the amplifier by a pair of electrodes. Microprocessor-controlled electronics, with a stable zero-point, convert the voltage into an analogue 4...20-mA output signal.

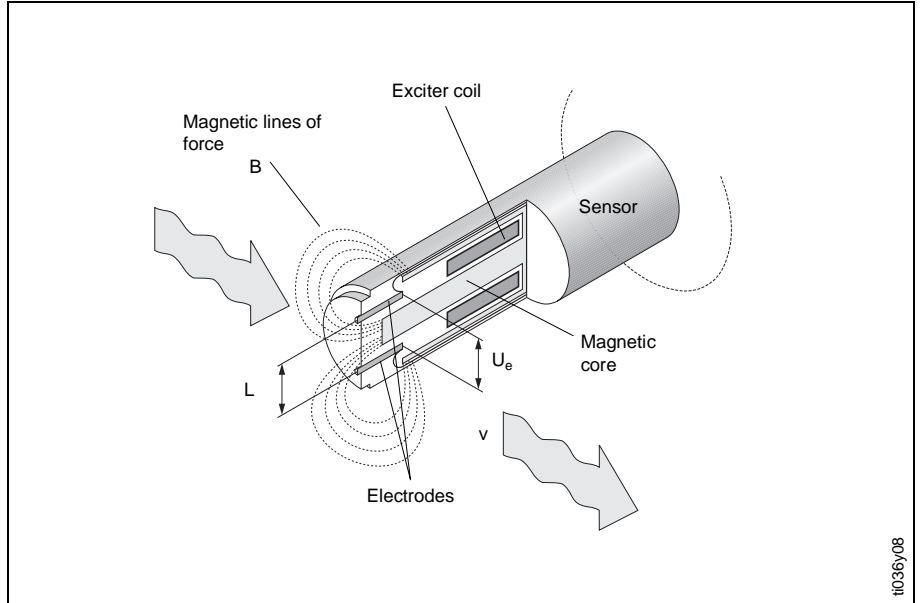

# Design

## Measuring system design

A construction overview of the Magphant measuring system is shown in the diagram below.

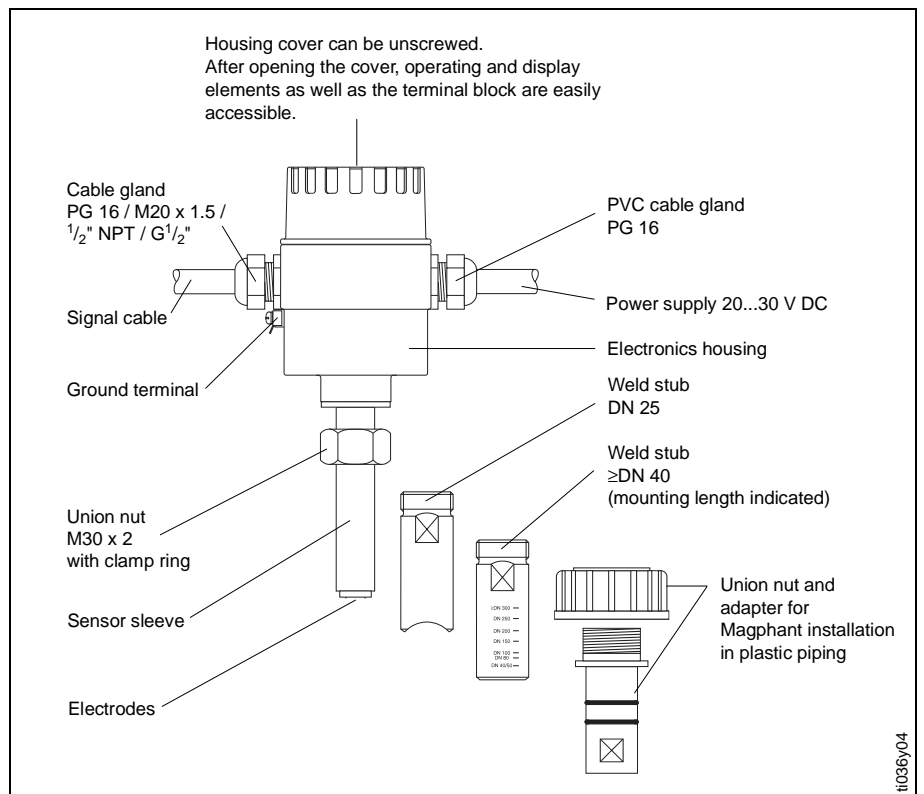

Measuring system design

# Mounting Instructions

## Orientation in the piping

The Magphant is best mounted in vertical piping.

If the piping runs horizontally, the Magphant is to be mounted to the side.

This mounting procedure ensures that the electrodes are always immersed in flowing fluid.

Caution!

Never weld the weld stub to the pipe with the Magphant in place.

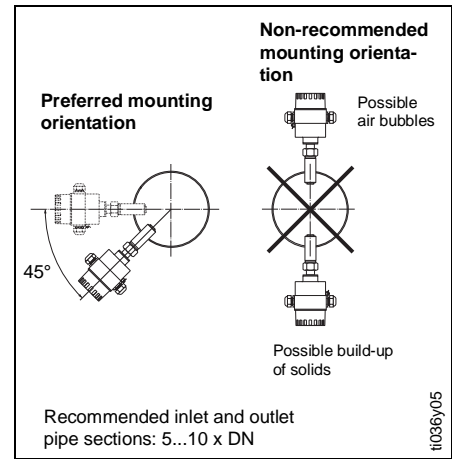

## Mounting in steel piping

### Weld stub

The Magphant is mounted using the weld stub supplied. Two different versions are available, depending on nominal diameter:

### Weld stub for DN 25

For DN 25 piping, the weld stub has the appropriate radius to match the diameter.

Opening in the piping:  $\varnothing = 23 \text{ mm}$   
Place the weld stub on the opening and weld it at right angles to the axis of the piping.

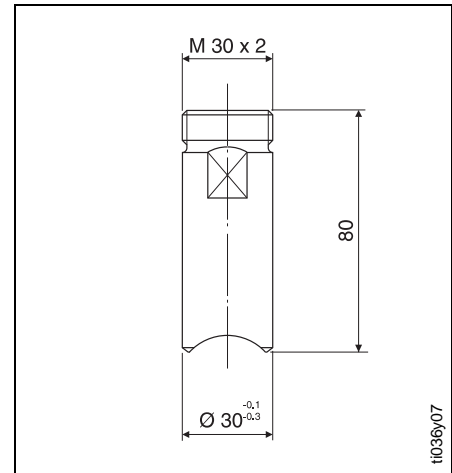

### Weld stub for $\geq \text{DN } 40$

For DN 40...300 piping, the weld stub has a graduated scale to ensure that the stub can be correctly positioned for mounting.

Opening in the piping:  $\varnothing = 30 \text{ mm}$   
Insert the weld stub into the opening, with the marking (according to the nominal diameter) flush against the outer wall of the piping and weld it at right angles to the axis of the piping.

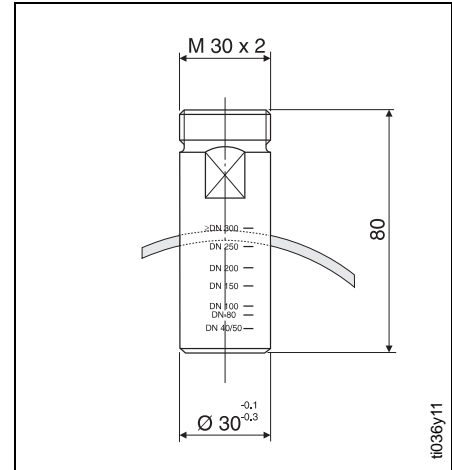

## Mounting in plastic piping

### Adapter piece for plastic piping

For mounting in plastic piping, Magphant is delivered with an adapter piece and a plastic union nut, with which Magphant can be mounted in a T-fitting (DN 15...DN 50) or a plastic weld stub ( $\geq \text{DN } 65$ ).

The T-fittings or plastic weld stubs can be obtained from Georg Fischer (+GF+).

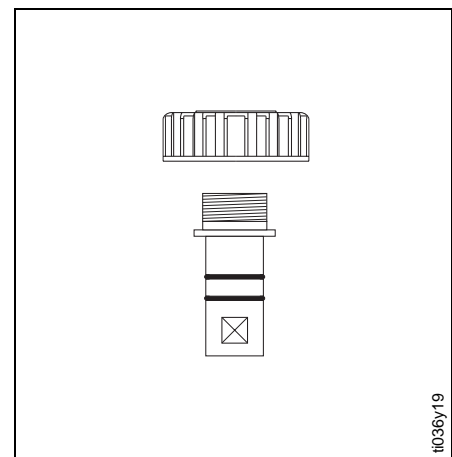

The T-fittings are available in PVC-U, PP and PVDF.

The weld stubs are available in PVC-U, PP and PE and must be adapted according to the diagram opposite and the given diameter. The length L can be calculated from the following formula:

$$L = 40 - S - E$$

S = wall thickness of the pipe

E = can be taken from the table below:

Pipe outside diameter	E
65	6.9
75	8.3
110	11.4
125	14.4
140	17.7
160	17.7
200	12.0
225	10.0
250	10.0
280	10.0
315	10.0
355	10.0
400	10.0
450	5.0
500	5.0
630	5.0

The total length (68 mm) must also be observed.

Hole in the pipe:  $\varnothing = 40$  mm

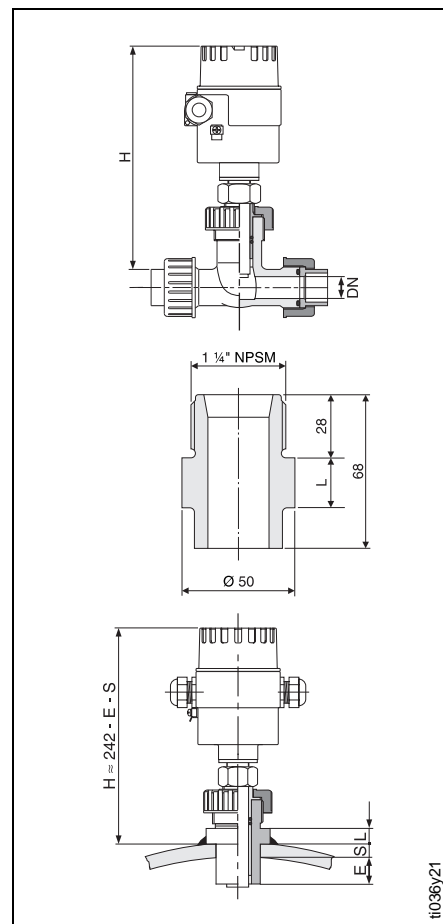

### Operational safety

- Comprehensive self-monitoring of the measuring system assures high safety. Any error messages that occur (process errors, instrument system errors) are immediately signalled via the current and relay outputs.
- The Magphant measuring system fulfils all general requirements for

electromagnetic compatibility (EMC) according to CE (EN 50081-1-2 and EN 50082-1-2).

- Protection type IP 66 is standard (DIN 40050).
- Magphant fulfils the EU directives for low-voltage and EMC and bears the CE mark.

## Electrical Connection

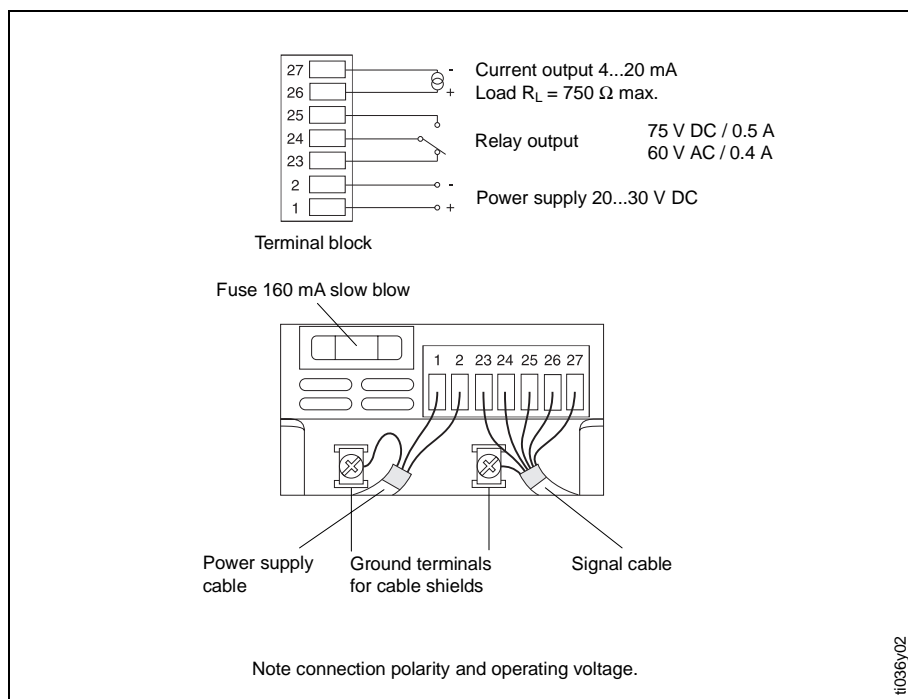

### Current output

The Magphant has an analogue output which is proportional to the flow. The 4...20-mA output signal can be used for other systems such as a PLCs, controllers, etc.

### Relay output

The Magphant also has a dry change-over contact which is especially suitable for monitoring purposes. Exceeding the range of set limit values (min./max. fail-safe) is indicated via this relay output.

### Warning!

Do not install, wire up or dismantle the instrument when the power supply is switched on.

# Operation

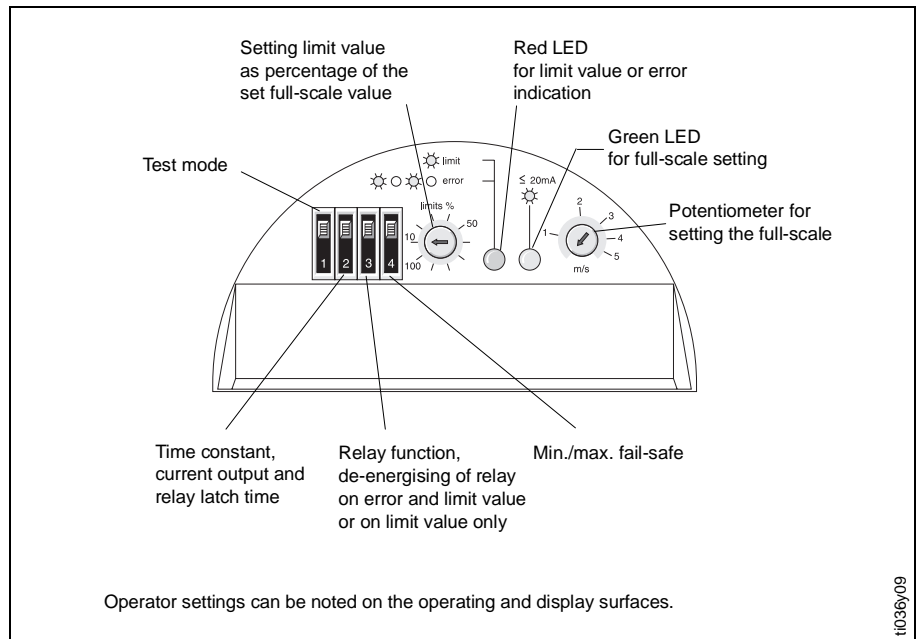

Operating and display surfaces

# Technical Data

## Dimensions and weight

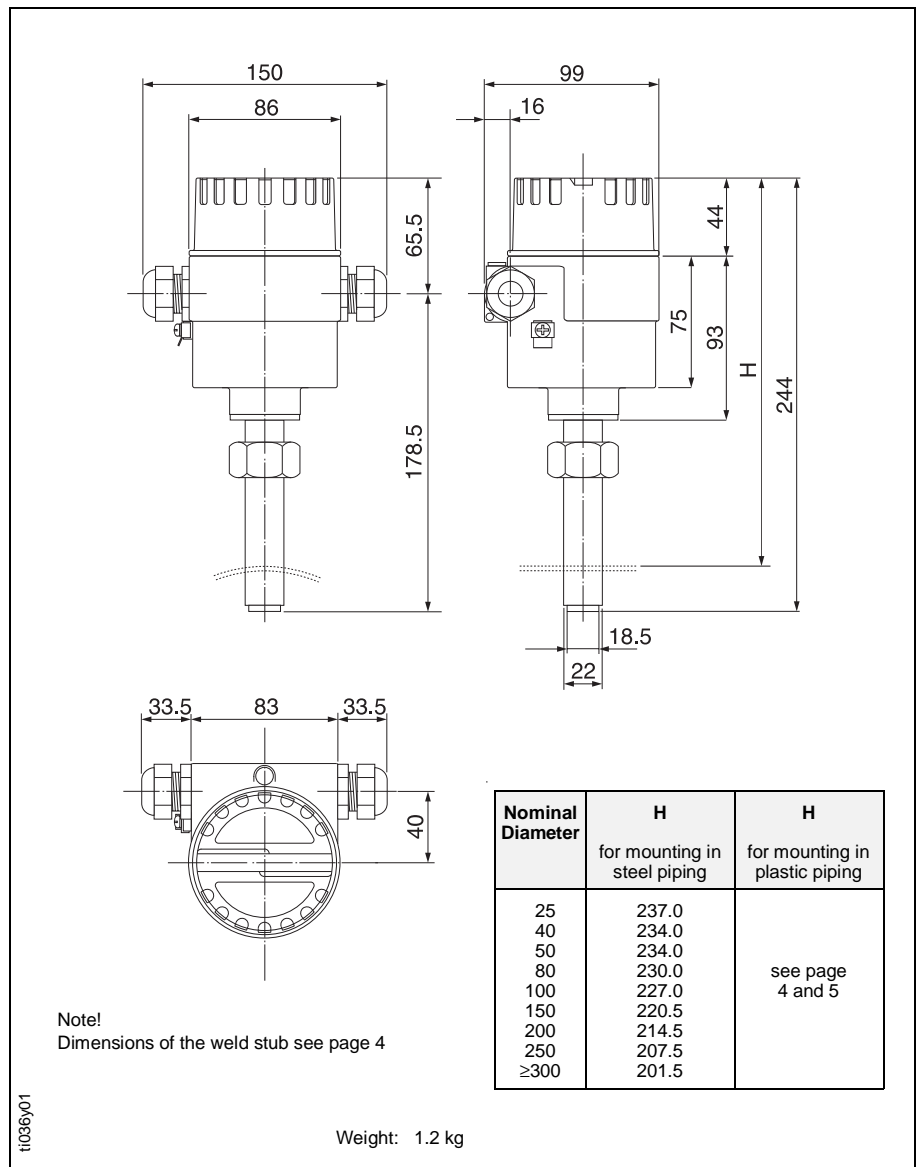

Dimensions and weight

Power supply	24 V DC (20...30 V DC)	
Power consumption	<2.5 W	
Outputs	<ul style="list-style-type: none"> <li>• Current output 4...20 mA, active The measuring system can measure flow in both directions, i.e. bidirectionally. The current output is always positive. The relay responds to both flow directions.</li> <li>• Relay output Potential-free change-over contact <span style="float: right;">60 V AC/0.4 A 75 V DC/0.5 A</span></li> </ul>	
Ambient temperature	-20...60 °C	
Process temperature	-20...120 °C (weld stub 1.4435 with clamp ring) -20...100 °C (weld stub St.37 with clamp ring and NBR gasket)	
Pressure	16 bar at 25 °C; 10 bar at 120 °C	
Full scale value	1...5 m/s (infinitely variable)	
Accuracy	±2% o.r. at measuring electrode with local calibration at flow velocities >1 m/s	
Reproducibility	±2% o.r.	
Conductivity	≥20 µS/cm	
Interference immunity	acc. to CE EN 50081-1-2 und EN 50082-1-2	
Protection type	IP 66 / NEMA 4X / Type 4X	

### Materials

Sensor	Sensor tip: PVDF, Viton O-ring  Electrodes: 1.4435/316L  Sensor sleeve: <ul style="list-style-type: none"> <li>• 1.4435/316L with 1.4571/316Ti clamp ring for 1.4435/316L weld stub</li> <li>• 1.4435/316L with clamp ring and NBR gasket for St.37/A570 weld stub</li> </ul>
Housing	Die-cast aluminium, epoxy powder coated
Weld stub (for steel piping)	1.4435/316L St.37/A570
Adapter piece (for plastic piping)	1.4435/316L (with 2 Viton O-rings)
Plastic union nut (for plastic piping)	PVC

### Approvals

CENELEC:  
 VDE 0165 manufacturers certificate for Zone 2  
 SEV: Ex nV/W IIC T4...T6, Ex Zone 2  
 FM: NI Cl I Div. 2 Groups ABCD; DIP/II, III/1/EFG. NEMA 4X  
 CSA: Class I Div. 2, Groups A, B, C and D;  
 Class II E, F and G, Class III; Type 4X

Thermal data and temperature classes for Ex Zone 2		
IEC 758	T <sub>fluid</sub> (see above)	T <sub>ambient</sub>
T1	100 °C/120 °C	60 °C
T2	100 °C/120 °C	60 °C
T3	100 °C/120 °C	60 °C
T4	100 °C/120 °C	60 °C
T5	95 °C/ 95 °C	60 °C
T6	80 °C/ 80 °C	40 °C

# Product Structure

## Version / Sensor gasket

- A1 Union nut for DN 25...2000 (1"...80")  
(only for weld on nipple)
- A2 For plastic pipes DN 15...1000 (1/2"...40")  
(only for adapter for plastic pipes)
- 99 other

## Mounting Nipples / Sensor gasket

- 1 Weld on nipple DN 25, St.37 / A570  
compression ferrule with NBR gasket
- 2 Weld on nipple DN 40...2000, St.37 / A570  
compression ferrule with NBR gasket
- 3 Weld on nipple DN 25, 1.4435 / 316L  
compression ferrule 1.4571 / 316Ti
- 4 Weld on nipple DN 40...2000, 1.4435 / 316L  
compression ferrule 1.4571 / 316Ti
- 5 Adapter for plastic pipes, 1.4435 / 316L  
compression ferrule NBR gasket
- 9 other

## Cable glands

- A PG16 cable glands
- B M20x1.5 threads for cable glands
- C 1/2" NPT threads for cable glands
- D G 1/2" threads for cable glands
- 9 other

## Approvals

- 1 Version for non-hazardous areas
- 2 VDE 0165 Certificate of Conformity
- 3 SEV, Ex Zone 2, Ex n approval
- 4 FM, NI CI I Div. 2 Gp ABCD
- 5 CSA, NI CI I Div. 2 Gp ABCD
- 9 other

## Options

- A Standard version
- 9 other

DTI 200 -										← Order code
-----------	--	--	--	--	--	--	--	--	--	--------------

# Supplementary Documentation

- Special Documentation Magphant (SD 016D/06/e)
- Operating Manual Magphant (BA 025D/06/e)

## Subject to modification

Endress+Hauser  
GmbH+Co.  
Instruments International  
P.O. Box 2222  
D-79574 Weil am Rhein  
Germany

Tel. (07621) 975-02  
Tx 773926  
Fax (07621) 975345

