

MPPT SOLAR CHARGE CONTROLLER

ICharger MPPT 6048

User Manual

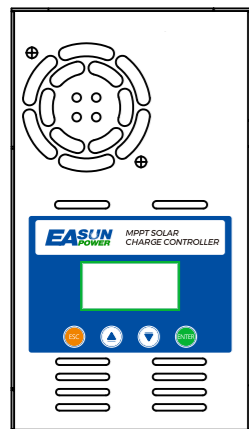

Reminder: The controllers can be installed indoor only.

Main Feature

- 60A MPPT solar charge controller
- MPPT technology
- Automatic battery voltage detection for 12V/24V/36V/48V
- 3-stage charging optimizes battery performance
- Overcharge protection, over-temperature protection
- Suitable for battery types such as sealed lead acid, vented gel and lithium battery, etc
- Easy to be mounted

Warning and Caution

Be aware that only qualified professionals could install these controllers. Please read all manuals before installing them.

- 1)Keep controller away from water. Don't use wet towel to wipe controller.
- 2)Keep wiring correct, don't reverse wiring. Please pay attention to terminal wiring sequence.
- 3)Keep controller in an environmental temperature from -20°C~+55°C. Avoid direct sunlight.
- 4)Keep good heat dissipation.
- 5)Use the pure copper wires and connect all polarity correctly.
- 6)The load output is only for DC load less 5A current.
- 7)Please don't set any parameters if you are not professional since the controller can work fine in default condition except lithium battery.

Air Circuit Breaker and Wires Requirement

Models	ICharger MPPT 6048
Copper wires	6mm²x2PCS
Air circuit breakers	100A

Wire Connection Sequences

For ICharger MPPT 6048, it's better to connect two wires to two PV+ and another two wires to two PV-. For BAT+ and BAT-, it's same way to connect wires.

Installation Steps

- 1.The battery voltage should be more than 12V, then the controller can boot up. Install air circuit breaker between controller and batteries. Turn off the circuit breaker, then connect batteries to controller with correct polarity.
- 2.Install air circuit breaker between controller and PV modules. Turn off the circuit breaker, and ensure the PV polarity correct, then connect wires between PV modules and controller.
- 3.Turn on the air circuit breaker between controller and batteries.
- 4.Turn on the air circuit breaker between controller and PV modules.

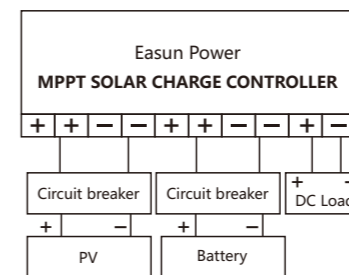

LCD Display Indication

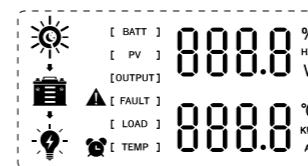

1.Display Introduction

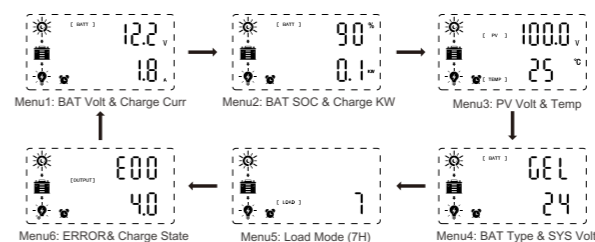

2.Battery Type Setting

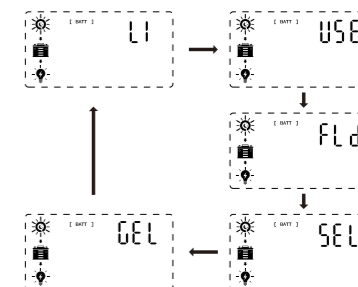

3.System Voltage Setting

(1)Battery Type = USE

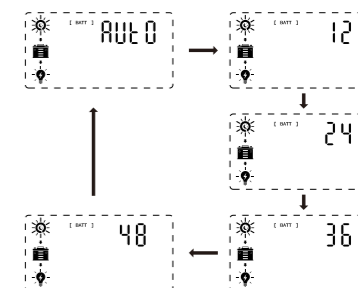

(2) Battery Type = LI

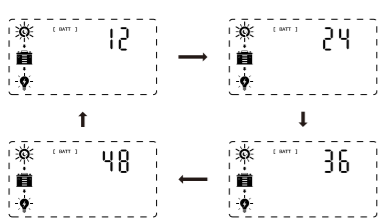

(2) Battery Type = LI

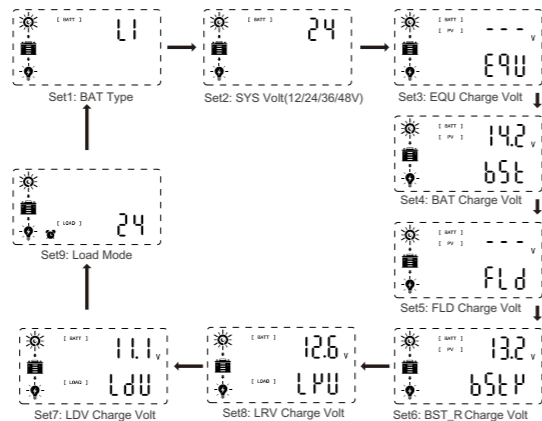

(3) Battery Type = SEL/GEL/FLD



(3) Battery Type = SEL/GEL/FLD

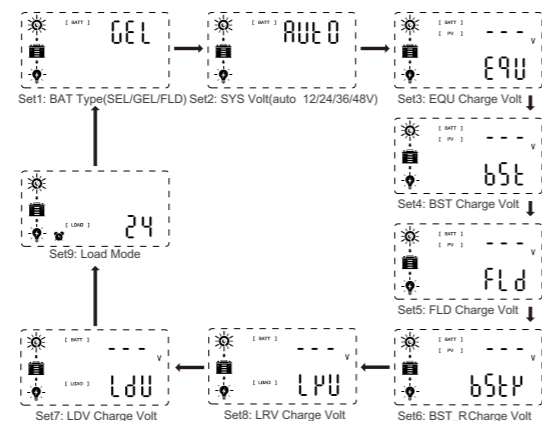

4.Parameter Setting

(1) Battery Type = USE

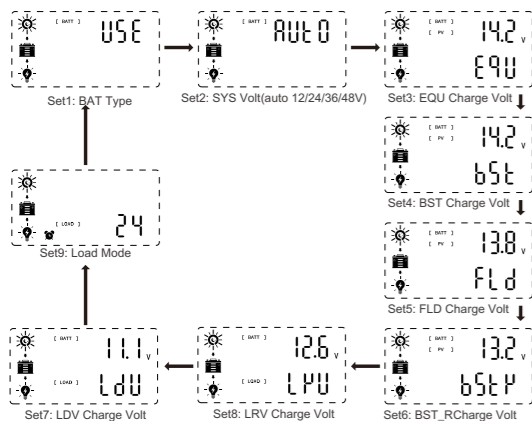

Press Key Operation

Function Key	System Mode	Operation	Operation Indication
[ENTER]	View Mode	Long Press	Enter SET mode
[▲]	View Mode	Short Press	Screen page down
[▼]	View Mode	Short Press	Screen page up
[ESC]	View Mode	Short Press	-

Function Key	System Mode	Operation	Operation Indication
[ENTER]	Setting Mode	Long Press	Exit from setting & saving the present settings data
		Short Press	Enter the next setting page
[▲]	Setting Mode	Short Press	Adjust the parameter by increase the value
[▼]		Short Press	Adjust the parameter by decrease the value
[ESC]	Setting Mode	Short Press	Exit SET Mode without saving data

Error Code

Code	Error
E00	No Error
E01	Battery over voltage
E02	PV over voltage
E08	Over-discharge
E20	Device over heating

Working Mode

Code	Working Mode
3.0	Night mode, no charging
4.0	MPPT mode
7.0	Absorption mode
8.0	Floating mode

Manual Setting

Caution! All steps must be carried out when the PV modules are disconnected to controller.

Batteries charge voltage reference

Battery Type	System Volt	EQU	BST	FLD	BST_R	LRV	LDV
GEL	Auto	---	14.2V	13.8V	13.2V	12.6V	11.1V
SEL	Auto	14.6V	14.4V	13.8V	13.2V	12.6V	11.1V
FLD	Auto	14.8V	14.6V	13.8V	13.2V	12.6V	11.1V
USE	Auto/12/24/36/48	Defined by GEL					
LI	12/24/36/48	---	Defined by GEL	---	---	---	Defined by GEL

Dimension

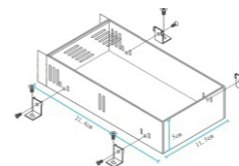

Notes: Please use our screws only since it may damage the internal PCB if using other screws. Please use proper torque to push the screws into casing since it may damage the internal PCB by strong torque.

Basic Parameter

Item	Parameter
Models	ICharger MPPT 6048
Charging mode	3-stage: constant current(MPPT), constant voltage, floating
System voltage	12/24/36/48/Auto
Max PV input power	720W/12V; 1440W/24V 2160W/36V; 2880W/48V
Max PV input voltage	180 Voc
Battery voltage automatic recognition	12V system (DC8.7V-DC15.5V) 24V system (DC16V-DC31V) 36V system (DC33V-DC41V) 48V system (DC42V-DC64V)
Overcharging protection voltage	12V system (16V) 24V system (32V) 36V system (48V) 48V system (64V)
Limited current protection	61A
Max efficiency	≥98.1%
PV utilization	≥99%
Auto Temperature Compensation	-3mV/2V°C
Protection Function	
Temperature protection	80°C
Fan-on temperature	>45°C
Fan-off temperature	<40°C
Properties	
Size (mm)	214x115x50
Net weight (Kg)	1.1
Gross weight (Kg)	1.2
Electromagnetic compatibility	Accord to EN61000, EN55022, En55024
Enclosure	IP21
Environmental temperature	-20°C ~ +55°C
Storage temperature	-40°C ~ +75°C