



FIBER ONESHOT™ PRO

Singlemode Fiber Troubleshooter

Users Manual

PN 3891247

March 2011

©2011 Fluke Corporation. All rights reserved. Printed in USA.

All product names are trademarks of their respective companies.

LIMITED WARRANTY AND LIMITATION OF LIABILITY

Fluke Networks mainframe products will be free from defects in material and workmanship for one year from the date of purchase. Parts, accessories, product repairs and services are warranted for 90 days, unless otherwise stated. Ni-Cad, Ni-MH and Li-Ion batteries, cables or other peripherals are all considered parts or accessories. This warranty does not cover damage from accident, neglect, misuse, alteration, contamination, or abnormal conditions of operation or handling. Resellers are not authorized to extend any other warranty on Fluke Networks' behalf.

To obtain service during the warranty period, contact your nearest Fluke Networks authorized service center to obtain return authorization information, then send your defective product to that Service Center with a description of the problem.

THIS WARRANTY IS YOUR ONLY REMEDY. NO OTHER WARRANTIES, SUCH AS FITNESS FOR A PARTICULAR PURPOSE, ARE EXPRESSED OR IMPLIED. FLUKE NETWORKS IS NOT LIABLE FOR ANY SPECIAL, INDIRECT, INCIDENTAL OR CONSEQUENTIAL DAMAGES OR LOSSES, ARISING FROM ANY CAUSE OR THEORY.

Since some states or countries do not allow the exclusion or limitation of an implied warranty or of incidental or consequential damages, this limitation of liability may not apply to you.

4/04

Fluke Networks
PO Box 777
Everett, WA 98206-0777
USA

SOFTWARE NOTICE

Copyright © 1986, 1988, 1991, 1993

The Regents of the University of California. All rights reserved.

© UNIX System Laboratories, Inc.

All or some portions of this file are derived from material licensed to the University of California by American Telephone and Telegraph Co. or Unix System Laboratories, Inc. and are reproduced herein with the permission of UNIX System Laboratories, Inc. Redistribution and use in source and binary forms, with or without modification, are permitted provided that the following conditions are met:

- 1 Redistributions of source code must retain the above copyright notice, this list of conditions and the following disclaimer.
- 2 Redistributions in binary form must reproduce the above copyright notice, this list of conditions and the following disclaimer in the documentation and/or other materials provided with the distribution.
- 3 Neither the name of the University nor the names of its contributors may be used to endorse or promote products derived from this software without specific prior written permission.

THIS SOFTWARE IS PROVIDED BY THE REGENTS AND CONTRIBUTORS "AS IS" AND ANY EXPRESS OR IMPLIED WARRANTIES, INCLUDING, BUT NOT LIMITED TO, THE IMPLIED WARRANTIES OF MERCHANTABILITY AND FITNESS FOR A PARTICULAR PURPOSE ARE DISCLAIMED. IN NO EVENT SHALL THE REGENTS OR CONTRIBUTORS BE LIABLE FOR ANY DIRECT, INDIRECT, INCIDENTAL, SPECIAL, EXEMPLARY, OR CONSEQUENTIAL DAMAGES (INCLUDING, BUT NOT LIMITED TO, PROCUREMENT OF SUBSTITUTE GOODS OR SERVICES; LOSS OF USE, DATA, OR PROFITS; OR BUSINESS INTERRUPTION) HOWEVER CAUSED AND ON ANY THEORY OF LIABILITY, WHETHER IN CONTRACT, STRICT LIABILITY, OR TORT (INCLUDING NEGLIGENCE OR OTHERWISE) ARISING IN ANY WAY OUT OF THE USE OF THIS SOFTWARE, EVEN IF ADVISED OF THE POSSIBILITY OF SUCH DAMAGE.

@(#)subr_prf.c 8.3 (Berkeley) 1/21/94

Contents

Introduction	1
Registering Your Product	1
The Fluke Networks Knowledge Base	1
Safety Information	2
Battery Installation and Life.....	4
Physical Features.....	4
Settings	8
The Connector Adapter	9
How to Clean Connectors.....	10
How to Use a Mechanical Device	10
How to Use Swabs, Wipers, and Solvent.....	11
About Launch and Receive Fibers	12
How to Use the Troubleshooter.....	13
How to Do Tests Through Attenuators	15
Measurement Results.....	15
Memory Functions.....	20
How to See Saved Results.....	20
How to Delete Saved Results	23
Maintenance	23
Contacting Fluke Networks.....	24
Options and Accessories	25
Specifications.....	26

Introduction

The FIBER ONESHOT™ PRO Singlemode Fiber Troubleshooter does these tests to help you find incidents on singlemode fiber optic cables:

- Measures the length of singlemode fiber optic cables
- Measures the distance to reflective and loss incidents
- Measures the reflectance and loss of incidents
- Maps the connections in singlemode fiber plants by showing the number of incidents on the fiber and the distance to each incident.

Registering Your Product





When you register your product with Fluke Networks you get access to valuable information on updates, troubleshooting procedures, and other support services.

To register online, go to www.flukenetworks.com/registration. Or, send the registration card that came with this product to Fluke Networks.

The Fluke Networks Knowledge Base

The Fluke Networks Knowledge Base gives answers to typical questions about Fluke Networks products and includes information on technology and procedures for network and cable tests. To see the Knowledge Base, go to www.flukenetworks.com, then click **Customer Support > Knowledge Base**.

Safety Information

	Warning or Caution: Risk of damage to or destruction of equipment or software. See explanations in the manual.
	Warning: Risk of electrical shock.
	Warning: Class 1 laser. Risk of damage to your eyes caused by hazardous radiation.
	Do not put products that contain circuit boards into waste containers. Refer to local regulations for disposal procedures.

Warning: Class 1 Laser

To prevent possible damage to your eyes caused by hazardous radiation:

- Do not look directly into optical connectors. Some optical equipment emits invisible radiation that can cause permanent damage to your eyes.
- Do not turn on the troubleshooter unless a fiber is attached to the port.
- Do not use a magnifying device to look at the optical outputs without the correct filter.
- Use of controls, adjustments, or procedures that are not in this manual can cause exposure to hazardous radiation.

Caution

To prevent damage to fiber connectors, to prevent data loss, and to make sure that your test results are as accurate as possible:

- Do not connect APC connectors to the troubleshooter. An APC connector will cause damage to the fiber endface in the connector on the troubleshooter. See Figure 3.

- **Connect only UPC connectors to the troubleshooter. Use only patch cords that comply with GR-326-CORE specifications and have UPC connectors. Other patch cords can cause unreliable measurements.**
- **Use the correct procedures to clean all fiber connectors before each test. If you do not do this or if you use incorrect procedures, you can get unreliable test results and can cause permanent damage to the connectors.**
- **Put protective caps on all connectors when you do not use them.**
- **Do not connect the troubleshooter to a network that is on. If you do, the troubleshooter can cause problems in the network.**
- **If ACTIVE LINE blinks, immediately disconnect the troubleshooter from the fiber. Optical power levels more than +7 dBm can cause damage to the detector in the troubleshooter.**
- **The troubleshooter senses optical signals between 1310 nm and 1550 nm. If there might be signals at other wavelengths on a fiber, use a different instrument to make sure that the fiber is not active before you connect the troubleshooter to the fiber.**

Battery Installation and Life

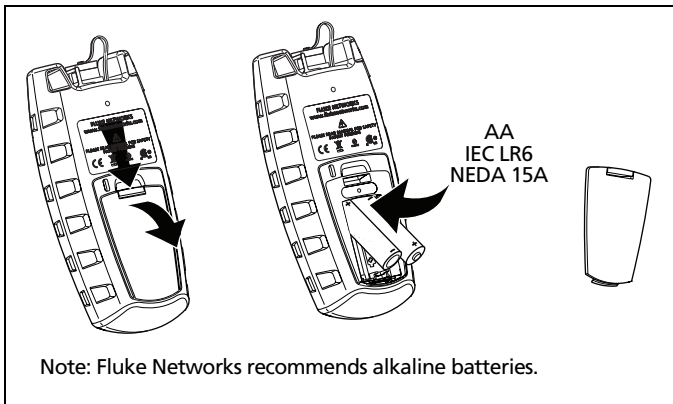

Figure 1. How to Install the Batteries

The troubleshooter can do approximately 1500 tests before you must replace the batteries.

Physical Features

See Figure 2.

- ① Output port with SC adapter and UPC endface
- ② Starts a test
- ③ On/off key
- ④ Navigation keys
- ⑤ Press or hold down to enter and exit the setup menu. Press to select an item, or to save a setting.
- ⑥ LCD display

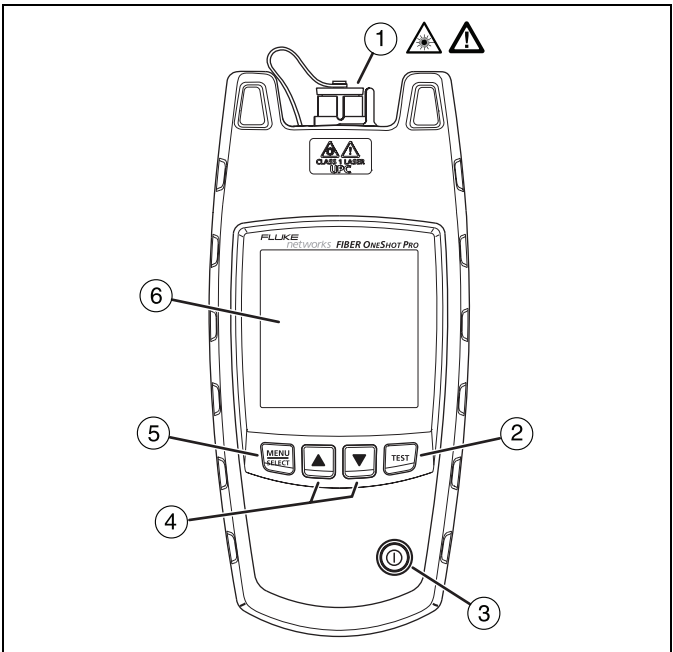

gmh04.eps

Figure 2. Physical Features

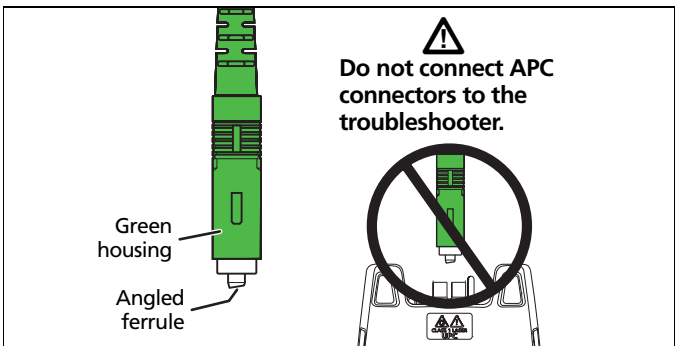

fjy06.eps

Figure 3. How to Identify an APC Connector

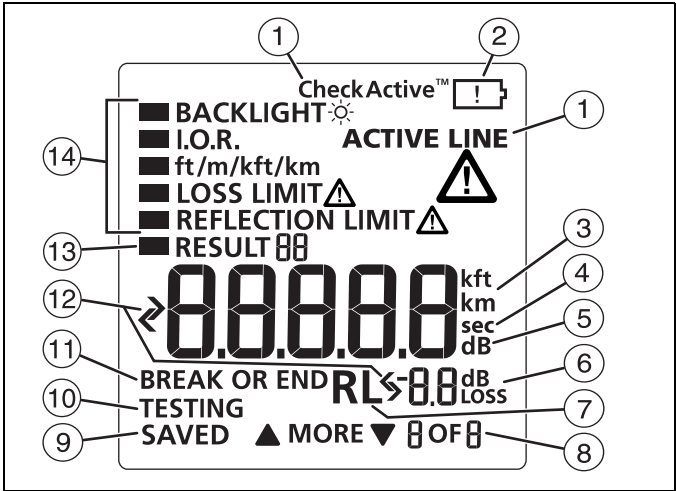

gmh01.eps





Figure 4. Display Features

- 1 When you press **TEST**, **CheckActive™** shows and the troubleshooter looks for an optical signal on the fiber. If there is a singlemode signal stronger than approximately -29 dBm on the fiber, **ACTIVE LINE** blinks and the troubleshooter will not do a test.

⚠ Caution









If **ACTIVE LINE** blinks, immediately disconnect the troubleshooter from the fiber. Optical power levels more than +7 dBm can cause damage to the detector in the troubleshooter.

- 2 When the low battery symbol shows, replace the batteries soon. See page 4.
- 3 The digits show the fiber length in feet, kilofeet, meters, or kilometers.
- 4 **sec** : Shows when you look at the setting for the backlight timer. The setting is in seconds.

- ⑤ **dB**: Shows when you look at the setting for the reflection limit. The setting is in decibels.
- ⑥ **dB**: Shows when the display shows the reflectance of an incident on the fiber. The measurement is in decibels.
dB Loss: Shows when the display shows the power loss of an incident on the fiber. The measurement is in decibels.
- ⑦ **RL**: Return loss. See page 22.
- ⑧ **▼ MORE ▲**: Shows when the troubleshooter finds more than one incident. Press   to see more incidents. The numbers show the number of the incident and the total number of incidents. The troubleshooter shows up to 9 incidents. If there are more than 9 incidents on the fiber, the last 9 blinks when you look at the ninth incident.
- ⑨ **SAVED**: Shows after a test. The troubleshooter automatically saves the test results.
- ⑩ **TESTING**: Shows as the troubleshooter does a test.
- ⑪ **BREAK OR END**: Shows when the troubleshooter shows the distance to a break or the end of the fiber.
- ⑫ : See page 18.
- ⑬ **RESULT**: Shows when you look at saved results. See page 20.
- ⑭ Settings for the troubleshooter. **LOSS LIMIT**  and **REFLECTION LIMIT**  blink if a measurement is equal to or greater than the limit you select.

Settings

To change the settings on the troubleshooter:

- 1 Hold down  until the settings menu shows.
- 2 To select a setting to change, press , then press .
- 3 Use   to change the setting.
- 4 Press  or  to save the setting.
- 5 To exit the settings menu, hold down  for 4 seconds. To exit and do a test, press .

BACKLIGHT

The display backlight turns off if you do not press a key for the period of time shown. You can set the time to 5 to 60 seconds in increments of 5 seconds.

I.O.R. (index of refraction)

The index of refraction is the ratio of the speed of light in a vacuum to the speed of light in a fiber. The troubleshooter uses the index of refraction to calculate length. If you increase n , the calculated length decreases. The default is 1.468. This value is satisfactory for most fibers.

ft/m/kft/km

Select feet, meters, kilofeet, or kilometers as the unit for length measurements. The default is feet.

LOSS LIMIT

Sets the minimum level at which the troubleshooter shows the warning **LOSS LIMIT**  for an incident. For example, if you select a limit of 2.0 dB, the troubleshooter shows the warning for incidents above 2.0 dB. You can select a value from 0.5 dB (lower loss) to 6.1 dB (higher loss) in 0.1 dB increments. The default is 0.5 dB.

REFLECTION LIMIT

Sets the minimum size at which the troubleshooter shows the warning **REFLECTION LIMIT**  for an incident. For example, if you select a limit of -35 dB, the troubleshooter shows the warning for incidents above -35 dB. You can select a value from -24 dB (larger reflection) to -62 dB (smaller reflection) in 1 dB increments. The default is -45 dB.

The Connector Adapter

The troubleshooter has an SC connector adapter that you can replace with another type of adapter, such as LC. See Figure 5.

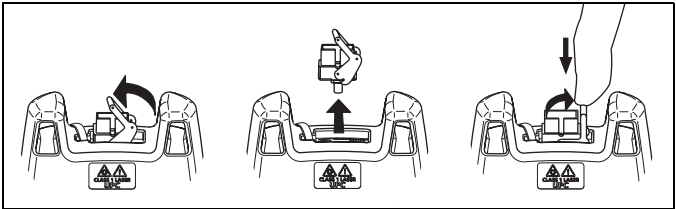

gmh08.eps

Figure 5. How to Remove and Install the Connector Adapter

How to Clean Connectors

Fluke Networks recommends that you use a mechanical device to clean connectors. If you do not have such a device, use other optical-grade supplies to clean connectors.

How to Use a Mechanical Device

Caution

To prevent damage to the device and to connectors, read all instructions and obey all safety precautions given by the manufacturer of the device you use to clean connectors.

- 1 To clean a bulkhead connector, remove the cap. To clean the connector on a fiber cable, remove only the tip of the cap.
- 2 If necessary for a bulkhead connector, extend the tip of the device.
- 3 Push the device straight into the connector until you hear a loud click. See Figure 6. Then remove the device.

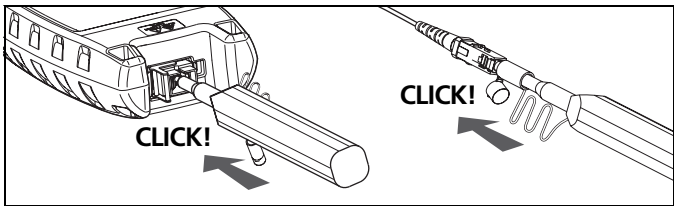

ghm09.eps

Figure 6. How to Use a Mechanical Device to Clean Connectors

How to Use Swabs, Wipers, and Solvent

To clean bulkhead connectors:

- 1 Touch the tip of an optical-grade solvent pen or swab soaked in solvent to a dry, optical-grade wiper.
- 2 Touch a new, dry swab to the solvent on the wiper.
- 3 Push the swab into the connector, twist it around 3 to 5 times against the endface, then discard the swab.
- 4 Twist a dry swab around in the connector 3 to 5 times.

To clean connector ends:

- 1 Touch the tip of an optical-grade solvent pen or swab soaked in solvent to a dry, optical-grade wiper.
- 2 Rub the connector endface across the solvent on the wiper, then rub it two times across the dry area of the wiper.

Note

A different procedure is necessary to clean some connector styles (for example, VF-45).

Before you make a connection, use a fiber microscope (for example, the Fluke Networks FIBERINSPECTOR™ Video Microscope) to do an inspection on the connector.

Always put protective caps on connectors that you do not use. At intervals, clean the caps with a swab or wipers and fiber optic solvent.

About Launch and Receive Fibers

Launch and receive fibers give the troubleshooter a better view of the first and last connectors in the link. If you do not use a launch fiber, the troubleshooter cannot detect the loss of the first connector in the link. If you do not use a receive fiber, the troubleshooter cannot detect the loss of the last connector in the link. Also, the reflectance measurement for the first and last connectors will be inaccurate.

Usually, you do not need to use a launch or receive fiber with the FIBER ONESHOT PRO tester. But you must use them in these situations:

- You must use a launch fiber if you want to detect a loss incident (such as a connector, splice, or macrobend) in the first 30 m of the fiber link.
- You must use a receive fiber if you want to detect the loss of the last connector in the fiber link.

If you use a launch or receive fiber, it must have a minimum length of 30 m (98 ft).

When you use launch or receive fibers, be sure to subtract their lengths from the length measurement to get the actual length of the fiber you are testing.

How to Use the Troubleshooter

Notes

Always use patch cords that comply with GR-326-CORE specifications and have a UPC connector at the end you will connect to the troubleshooter. Other patch cords can cause unreliable measurements and damage to the troubleshooter.

Do not use the troubleshooter to do tests on fibers that have PC connectors. PC connectors cause large reflections that the troubleshooter shows as the end of the fiber.

- 1 Clean all fiber connectors.
- 2 Connect the fiber to the troubleshooter, as shown in Figure 7.
- 3 Turn on the troubleshooter, then press . The troubleshooter automatically saves the results.

Note

After you turn on the troubleshooter, it shows PASS for a short time to show that it operates correctly.

Caution

If ACTIVE LINE blinks, immediately disconnect the troubleshooter from the fiber. Optical power levels more than +7 dBm can cause damage to the detector in the troubleshooter.

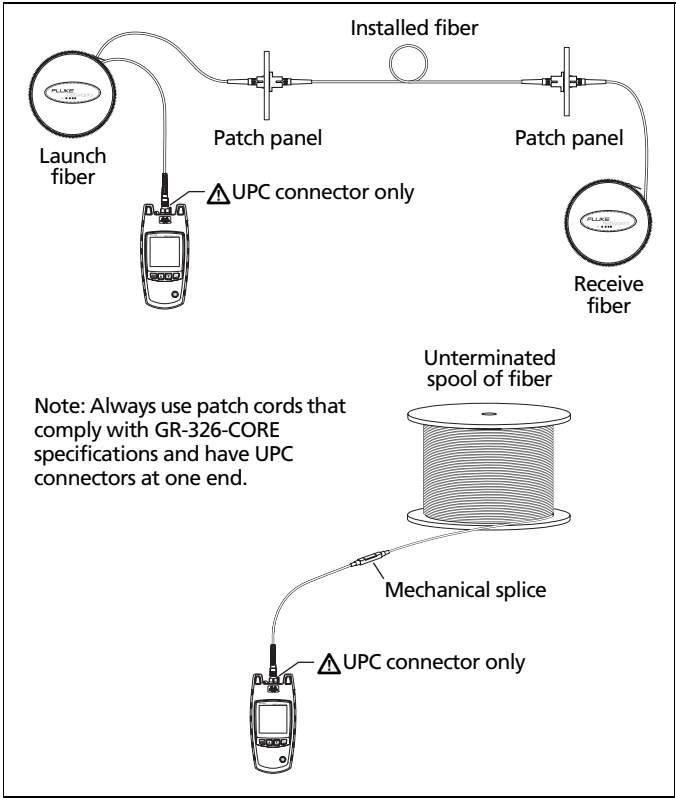

Note: Always use patch cords that comply with GR-326-CORE specifications and have UPC connectors at one end.

gmh05.eps

Figure 7. How to Make Connections

How to Do Tests Through Attenuators



The troubleshooter gives accurate results through attenuators that have 1 dB to 2 dB of attenuation.

Attenuators with more than 2 dB can possibly cause the troubleshooter to miss events. To do tests on fibers that have attenuators with more than 2 dB, connect directly to the fiber after the attenuator. In general, you should not do tests through attenuators.

Measurement Results

The troubleshooter measures the loss and reflectance of incidents on the fiber and the distance to the incidents. Typically, an incident is the end of the fiber, a connection, or a fault such as a break or a bad splice. See Figures 8 and 9.

If there is a break or an open connection on the fiber, the troubleshooter does not show incidents after the break.

- To see the results for other incidents, press  . The troubleshooter shows up to 9 incidents.
- To switch between measurements of reflectance and loss for an incident, press .

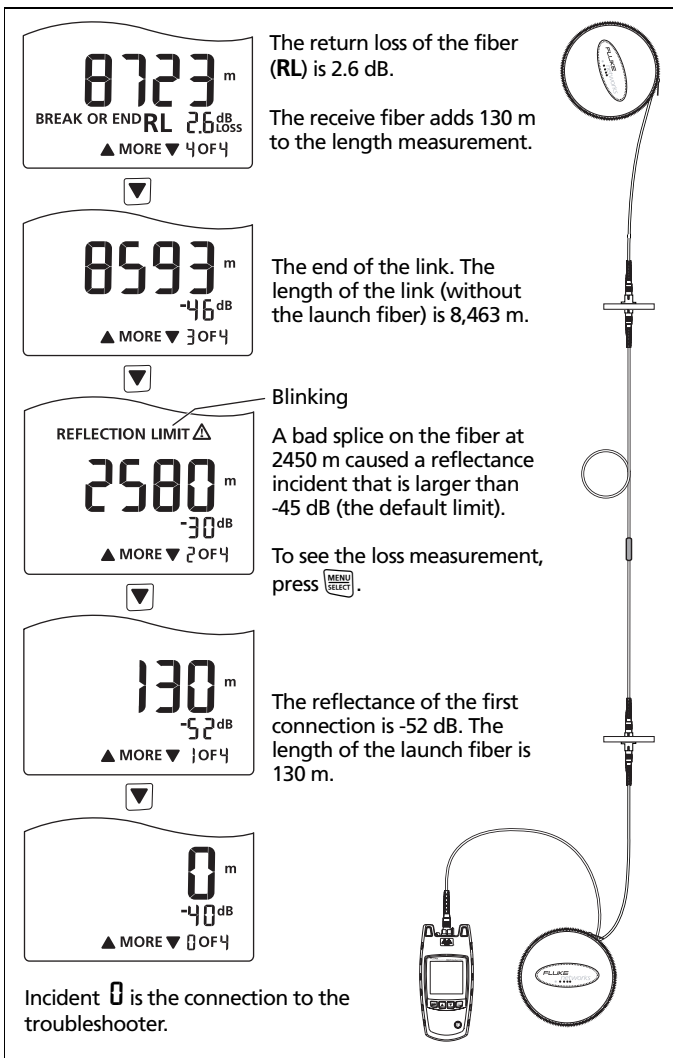

Figure 8. Examples of Measurement Results

gmh02.eps

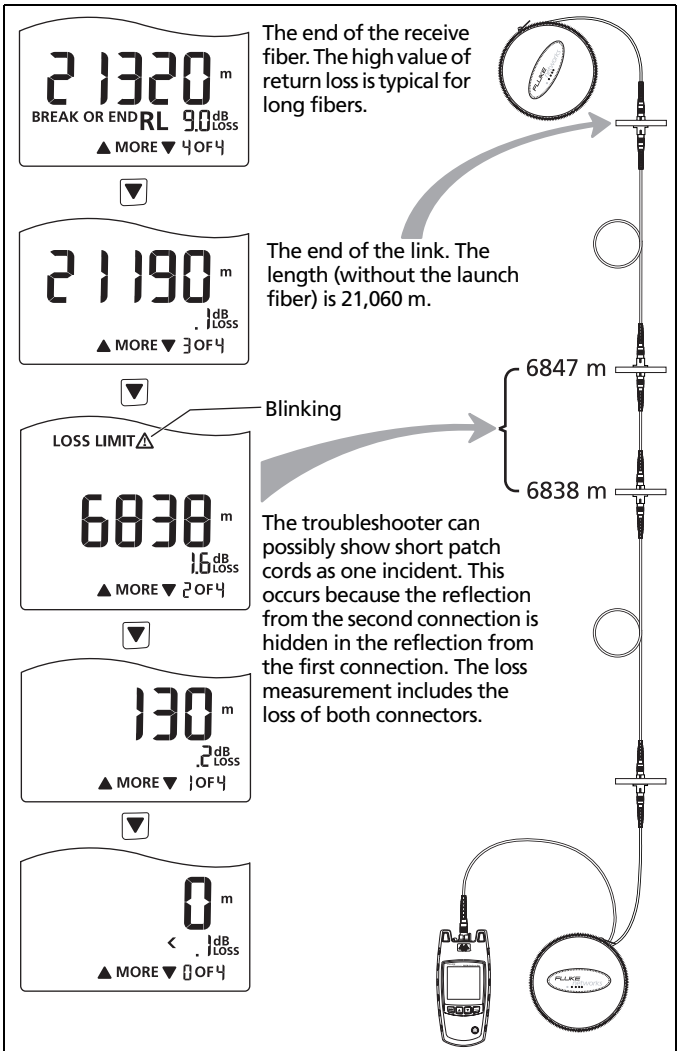

Figure 9. Results from a Link with a Short Patch Cord

If the reflectance or loss of a connection is higher than the limit:

- A connector endface is dirty or damaged.
- A connector is loose.
- The cable is damaged within about 3 m of the connector.
- The connection is between fibers of different types.
- The fiber has a bad splice or a sharp bend.

Notes

If you used launch and receive fibers, be sure to subtract their lengths from the length measurements.

The troubleshooter does not save the loss and reflection limits you used for the test.

The next time you do a test, the measurement (reflectance or loss) that shows first is the one you looked at last.

The troubleshooter can show these results in the given situations:

The troubleshooter shows 0 m or 0 ft.

- The connection to the troubleshooter is bad.
- The connector on the troubleshooter or the fiber is dirty. See page 10 for instructions on how to clean the connectors.
- A break, bad connection, or the end of the fiber is less than 2 m from the troubleshooter.
- The troubleshooter is connected to a PC connector. PC connectors cause large reflections that the troubleshooter shows as the end of the fiber.

The troubleshooter shows >23000 m or >75459 ft.

The fiber is longer than the troubleshooter can measure.

The troubleshooter shows < with the length measurement.

On some short fibers, small reflections are hidden in the reflection from the bulkhead connector on the troubleshooter. In these situations, the troubleshooter shows a range (for example, < 9 m), rather than an exact length. This often occurs on short fibers that have APC connectors.

The troubleshooter shows < $\frac{1}{2}$ dB_{LOSS}.

The loss measurement is less than the troubleshooter can show on the display.

The troubleshooter shows < -62 dB for a reflectance measurement.

The troubleshooter does not show an exact measurement for reflective incidents smaller than -62 dB.

The troubleshooter shows > -24 dB for a reflectance measurement.

The troubleshooter does not show an exact measurement for reflective incidents larger than -24 dB.

The length measurement is incorrect.

- The I.O.R. (index of refraction) is incorrect. See page 8.
- The fiber is very short (less than 2 m). The condition of the connectors on the meter and the fiber can affect length measurements on short fibers.



When you look at a result that has more than 9 incidents, the last 9 blinks and BREAK OR END does not show.

There are more than 9 incidents on the fiber. To see the incidents after the ninth incident, do a test from the other end of the fiber.



Memory Functions

The troubleshooter automatically saves the results of each test in non-volatile memory. The troubleshooter can save up to 99 results. After that, it replaces the oldest saved results with the results from a new test.

How to See Saved Results

- 1 Hold down  until the settings menu shows.
- 2 With **RESULT** selected, press . The troubleshooter shows the result from the most recent test. The number next to **RESULT** shows the sequence of the result in memory.
- 3 Figure 10 shows how to scroll through the results.

Notes

*Saved results do not include the loss and reflection limits you used for the test. **LOSS LIMIT**  and **REFLECTION LIMIT**  blink when a measurement is more than the limit that the settings show currently.*

The display shows nonE if no results are in memory.

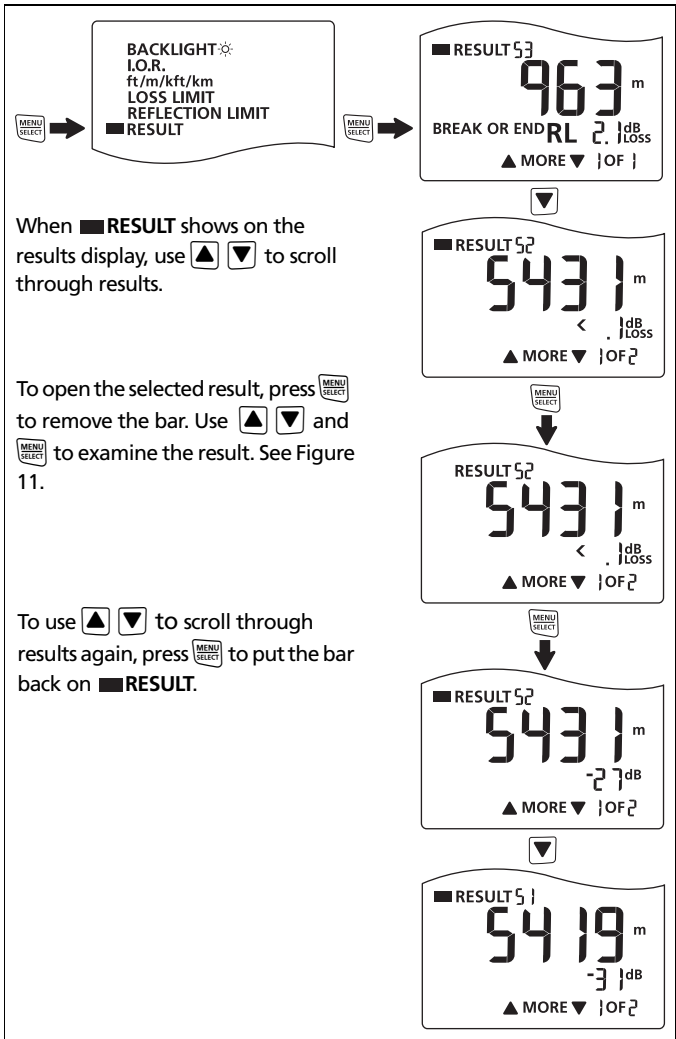

gmh03.eps

Figure 10. How to Scroll Through Saved Results

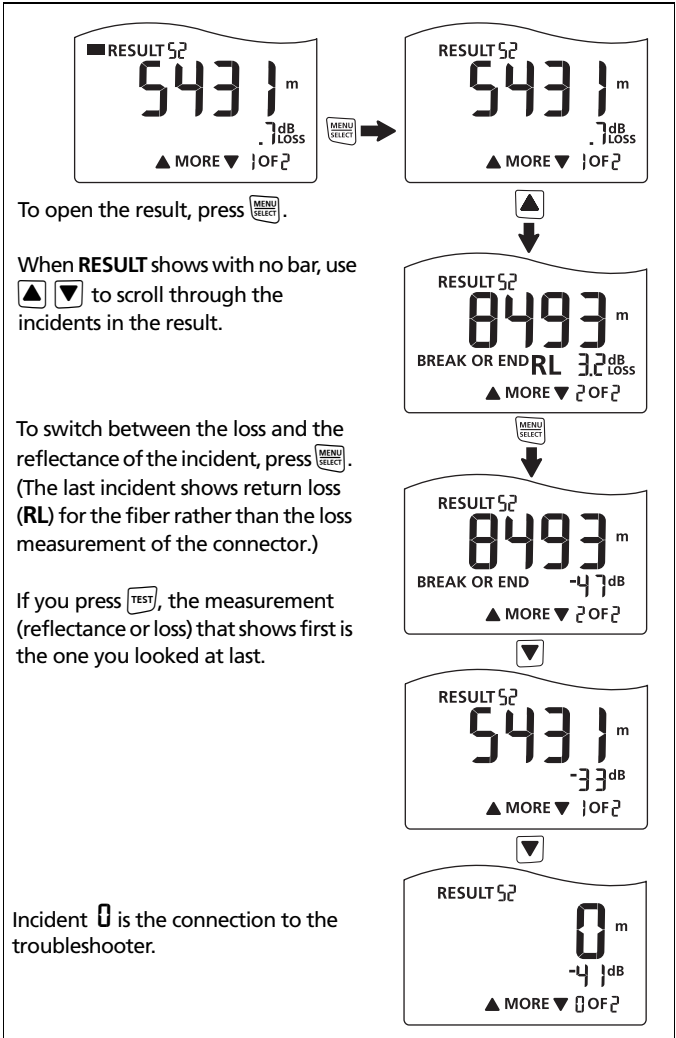







gmh07.eps

Figure 11. How to Examine a Saved Result

How to Delete Saved Results

Note

This procedure deletes all saved results. You cannot delete individual results.

- 1 Hold down  until the settings menu shows.
- 2 With **RESULT** selected, press  to see the results display.
- 3 Hold down  for 4 seconds. **dELP** blinks.
- 4 To delete all tests, press . The display shows **dEL** to show you that the tests were deleted.
- 5 To exit and not delete tests, press  or .

Maintenance

To clean the display, use lens cleaner and a soft, lint-free cloth. To clean the case, use a soft cloth that is moist with water or water and a weak soap.

Caution

To prevent damage to the display or the case, do not use solvents or abrasive materials.

To clean the optical connector, use the procedure given on page 10.

Warning

To prevent possible fire, electrical shock, personal injury, or damage to the troubleshooter:

- Do not open the case. You cannot repair or replace parts in the case.
- Use only replacement parts that are approved by Fluke Networks.

- If you replace parts that are not specified as replacement parts, the warranty will not apply to the product and you can make the product dangerous to use.
- Use only service centers that are approved by Fluke Networks.

Note

If the troubleshooter shows **ERROR**, servicing is necessary. Speak to a Fluke Networks representative. See page 24.

Contacting Fluke Networks



www.flukenetworks.com



support@flukenetworks.com



+1-425-446-4519

- Australia: 61 (2) 8850-3333 or 61 (3) 9329 0244
- Beijing: 86 (10) 6512-3435
- Brazil: 11 3759 7600
- Canada: 1-800-363-5853
- Europe: +31-(0) 40 2675 600
- Hong Kong: 852 2721-3228
- Japan: 03-6714-3117
- Korea: 82 2 539-6311
- Singapore: +65-6799-5566
- Taiwan: (886) 2-227-83199
- USA: 1-800-283-5853

For more phone numbers, go to our website.

Options and Accessories

For a complete list of options and accessories go to the Fluke Networks website at www.flukenetworks.com.





Option or Accessory	Fluke Networks Model Number
SIMPLIFIBER PRO Multimode Fiber Verification Kit	FTK1000
VISIFAULT™ Visual Fault Locator	VisiFault
FT500 FIBERINSPECTOR™ Mini Video Microscope	FT500
FT500 FIBERINSPECTOR™ Mini Video Microscope and Fiber Optic Cleaning Kit	FT525
FT120 FIBERVIEWER™ Microscope, 200X	FT120
FT140 FIBERVIEWER™ Microscope, 400X	FT140
Fiber Optic Cleaning Kit with carrying case	NFC-Kit-Case
Fiber Optic Cleaning Kit	NFC-Kit-Box
Launch/receive fiber, 9/125 µm, SC/UPC to SC/UPC, 130 m	NFK3-LAUNCH
Launch/receive fiber, 9/125 µm, SC/UPC to ST/UPC, 130 m	NFK3-LAUNCH-ST
Launch/receive fiber, 9/125 µm, SC/UPC to LC/UPC, 130 m	NFK3-LAUNCH-LC
Launch/receive fiber, 9/125 µm, SC/UPC to FC/UPC, 130 m	NFK3-LAUNCH-FC
Singlemode patch cord, 9/125 µm, SC/UPC to SC/UPC, 2 m	FIBR-AC-UUPC-2M
ST/ST singlemode fiber optic adapter	NF300SM
SC/SC singlemode fiber optic adapter	NF310SM
Soft carrying case and holster	FIBR-AC-CH

Specifications

Specifications are typical.

Operating temperature with the battery	0°C to 50°C
Non-operating temperature	-20°C to 60°C
Operating relative humidity (without condensation)	95% (10°C to 35°C) 75% (35°C to 40°C) uncontrolled < 10°C
Vibration	Random, 5 Hz to 500 Hz, MIL-PRF-28800F CLASS 2
Shock	1 meter drop test
Safety	CSA C22.2 No. 61010.1:04 EN 61010-1 2nd Edition 2001 EN60825-1, 2:2006
Altitude	3000 m
EMC	EN 61326-1: 2004
Battery type	2 AA alkaline batteries (no battery charger)
Battery life	1500 tests (typical)
Laser safety	Class 1 CDRH Complies to EN 60825-2
LCD type	Backlit black and white (segments)

Index of refraction range	1.45 to 1.5 (factory default is 1.468)
Auto turn off	Automatically turns off after 5 minutes if no keys are pressed. Backlight turns off first.
Memory for settings and test results	Non-volatile memory. Saves the results from up to 99 tests.
Factory calibration interval	None
Output wavelengths	1550 nm \pm 25 nm
Laser classification	Class 1 CDRH Complies to EN 60825-2
Reflectance threshold	User-selectable from -24 dB to -62 dB
Loss threshold	User-selectable from 0.5 dB to 6.1 dB
Distance to the first reflective open	2 m
Shortest distance to an open APC connection	15 m
Maximum distance	23 km (14.3 miles or 75,459 ft)
Distance accuracy (0 m to 23,000 m or 0 ft to 7,549 ft)	\pm 1 m for reflective incidents \pm 1 % of length \pm 3 m for non-reflective incidents \pm 1 % of length
Testing speed	< 10 seconds typical
Connector	Removable/cleanable SC adapter, UPC polish
Fiber types tested	9/125 μ m singlemode

Bulkhead quality	If no fiber is attached or if the connector is dirty, the troubleshooter displays 0 m or 0 ft.
Live fiber detection	Detects optical signals at 1310, 1490, and 1550 nm and shows ACTIVE LINE if a signal is there. Looks for a signal every 3 seconds after the first detection. +7 dBm maximum input power.
	Conforms to relevant European Union directives
 N10140	Conforms to relevant Australian standards
 C [®] US	Listed by the Canadian Standards Association CSA C22.2 No. 61010.1.04
	Conforms to FCC Rules, Part A, Class A