

Servo motor datasheet

Inspection Controlled:

Controlled date:

Unannotated technical requirements according to the following implementation

- 1、Unannotated dimensional tolerances according to GB1804-m;
- 2、Unspecified dimensional tolerances according to GB1184-k;

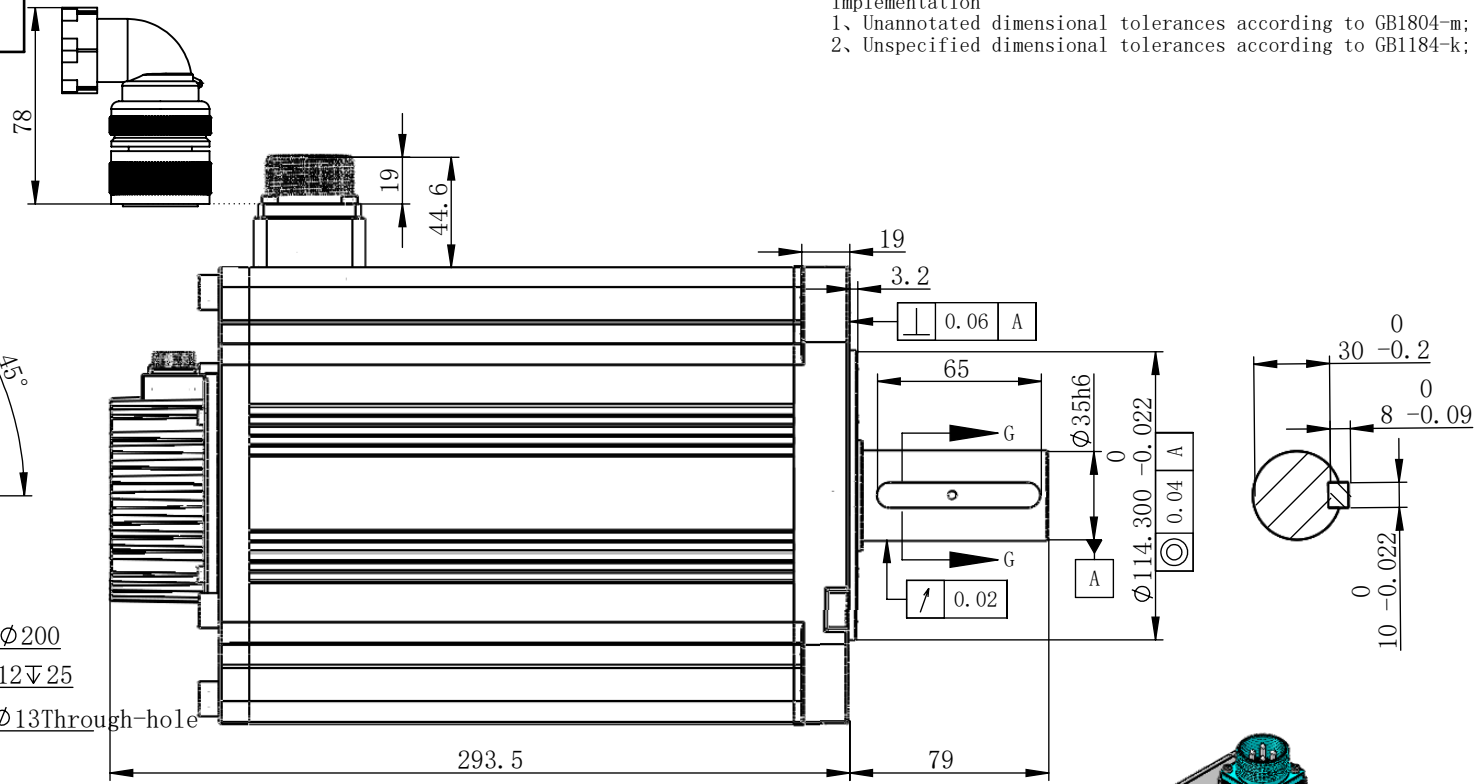
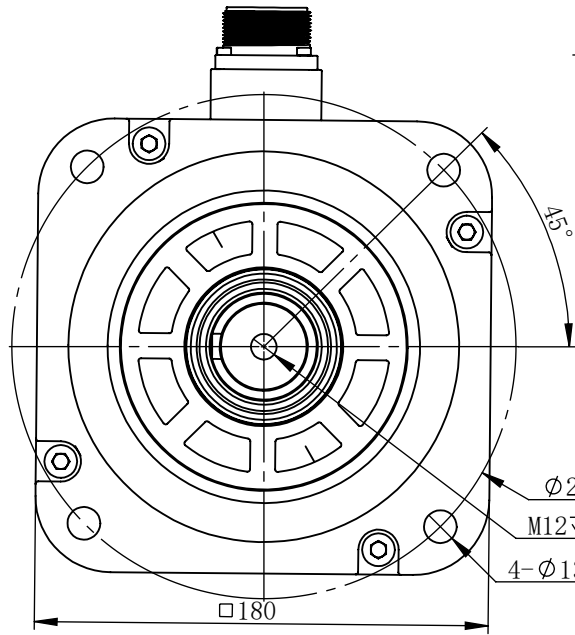

Connector	CMS3102A22-22P-Z			
Pin No.	A	B	C	D
Signal	U	V	W	PE
Colour	Red	Blue	Black	Yellow/green

Connector	16M-9H								
Pin No.	1	2	3	4	5	6	7	8	9
Signal	5V	0V	E+	E-	SD+	SD-	PE	/	/
Colour	Red	Black	Brown	White	Blue	Yellow	Shield	/	/

Motor technical specifications					
Name	Data	Unit	Name	Data	Unit
Rated power	7500	W	Rated voltage	380	V
Rated speed	1500	rpm	Max. speed	2000	rpm
Rated current	17	A rms	Peak current	42.5	A rms
Rated torque	47.75	N.m	Peak torque	119.38	N.m
Rotor inertia	156.6	$\text{Kg. m}^2 \times 10^{-4}$	Feedback element	23bit multi-turn absolute	

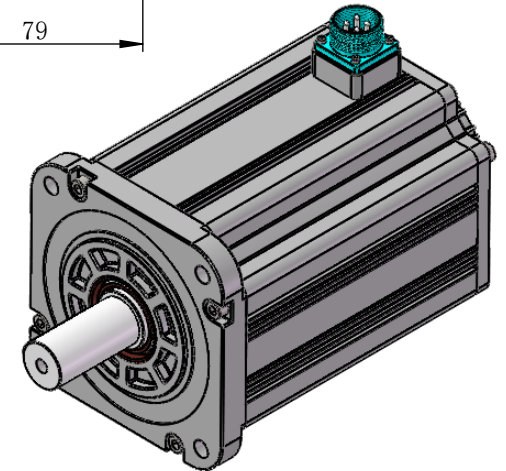
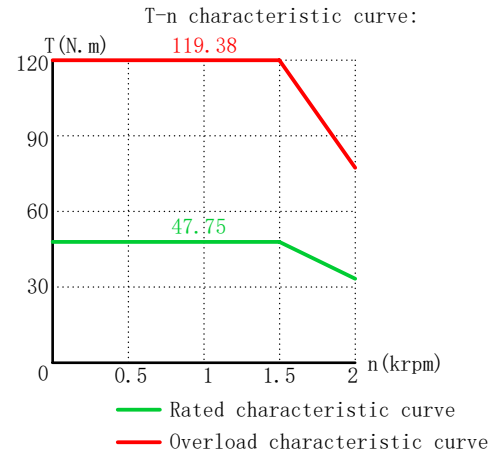

Suzhou Veichi Electric Co., Ltd View:

Material: Servo Motor

Design: Pan Yijia

Material Code: 9120122312

Date: 21-10-26

Specifications: V7E-M18D-7R515-D1 VersionA0