



GEAR PUMPS

GROUP 2

MODEL MGP

SERIES K

WWW.OLEDDINAMICAMOZIONI.IT

GEAR PUMPS SERIES "K" MANUFACTURED BY OLEODINAMICA MOZIONI ARE THE MOST USED IN HYDRAULIC UNITS IN THE HYDRAULIC SYSTEMS OF MOBILE MACHINES AND CONFORM TO INTERNATIONAL STANDARDS.

WE USE THE ADVANCED WORLD'S CONCEPTS – IMPROVING THE TECHNICAL CHARACTERISTICS OF THE PRODUCT, USE ONLY HIGH QUALITY MATERIALS AND HARDWARE MANUFACTURERS OF THE WORLD AT ALL STAGES OF DESIGN AND PRODUCTION. THE QUALITY MANAGEMENT SYSTEM CONFORMS INTERNATIONAL STANDARD ISO 9001: 2008.

GEAR PUMPS SERIES "K" OF OLEODINAMICA MOZIONI HAVE HIGH VOLUMETRIC AND MECHANICAL EFFICIENCY, LOW NOISE AND OPERATE RELIABLY IN A VARIETY HYDRAULIC SYSTEMS AND MOBILE MACHINERY.

- DIMENSIONS OF THE PUMPS ARE ACCORDING TO INTERNATIONAL STANDARDS SAE, DIN, EUROPEAN.
- GEAR PUMPS ARE SUPPLIED IN NEXT GROUPS: MGP1K, MGP2K, MGP2.5K, MGP3K WITH DISPLACEMENTS FROM 1 TO 90 CM³/REV.
- MAXIMUM CONTINUOUS PRESSURE UP TO 250 BAR.
- MOUNTING FLANGES AND REAR COVERS ARE PRODUCED WITH ALUMINIUM OR CAST IRON.
- BUILT-IN VALVES IN REAR COVER.
- MULTIPLE UNITS AVAILABLE WITH SEPARATED OR COMMON INLET FOR STAGES.
- PUMPS WITH BEARING SUPPORT FOR HEAVY DUTY APPLICATIONS.

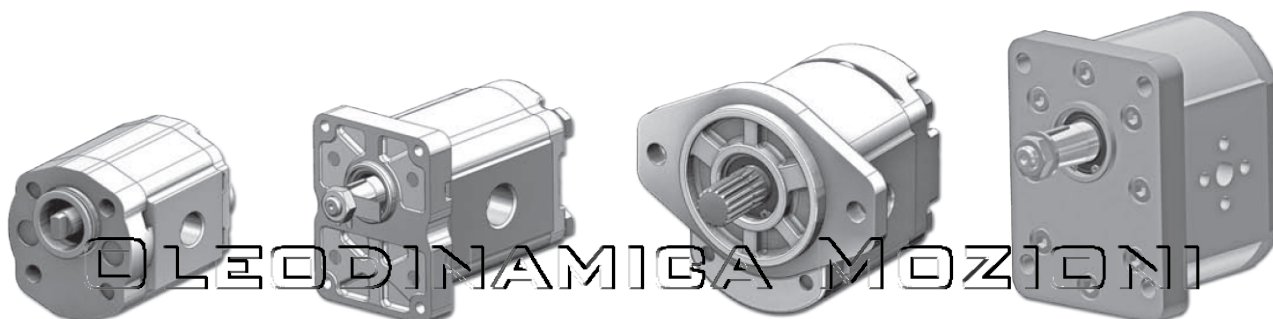

GEAR PUMPS SERIES "K" ARE MANUFACTURED WITH THRU-BOLT OF ROLLED ALUMINIUM, MOUNTING FLANGES AND REAR COVERS EITHER IN ALUMINIUM OR IN CAST IRON FOR MOBILE MACHINES, WHERE THERE ARE INCREASED REQUIREMENTS FOR THE NOISE LEVEL. GEAR PUMPS SERIES "K" HAVE HIGH ANTI-FRICTION AND STRENGTH CHARACTERISTICS. THE SEALS REDUCE INTERNAL FLOW OF THE FLUID AND TO ACHIEVE A HIGH VOLUMETRIC EFFICIENCY.

1. DRIVE SHAFT
2. DRIVEN SHAFT
3. BEARING HOUSING
4. BODY
5. SLIDE BEARING
6. MOUNTING FLANGE
7. REAR COVER
8. COMPENSATION SEAL
9. ANTI-EXTRUSION PLATE
10. SEALING RING
11. SHAFT SEAL
12. STOP RING
13. CENTERING PIN
14. SCREW
15. WASHER

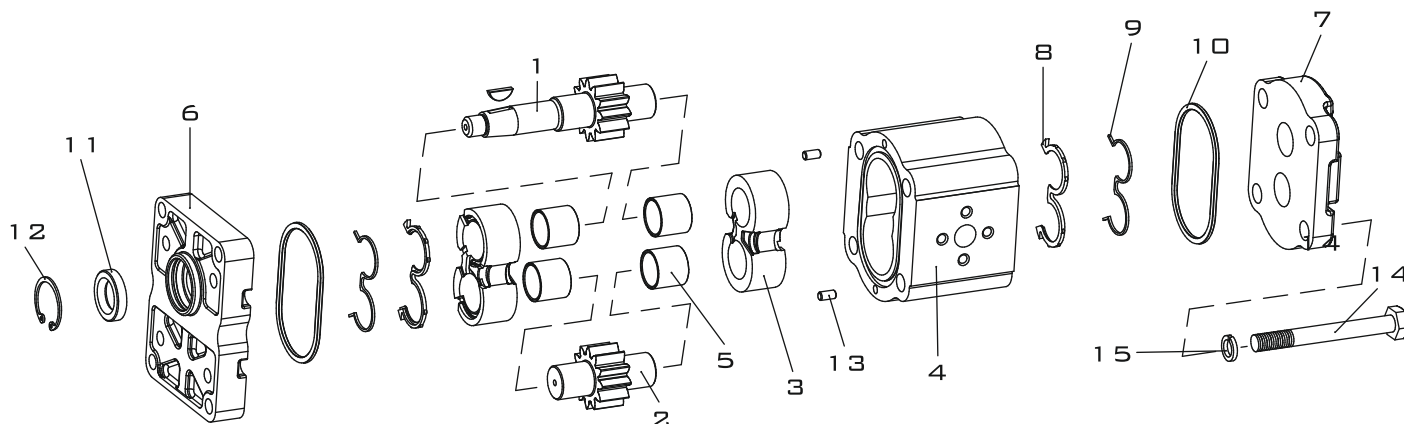



POMPE AD INGRANAGGI

MGP2K

GEAR PUMPS
GROUP 2

WORKING CONDITIONS

INLET PRESSURE (MAX.)	0.5 – 2.5 BAR
MIN. OPERATING FLUID VISCOSITY	10 MM ² /SEC
MAX. STARTING VISCOSITY (COLD START)	1000 MM ² /SEC
FLUID VISCOSITY RECOMMENDED RANGE	17 – 65 MM ² /SEC
FLUID OPERATING TEMPERATURE RANGE WITH NBR SEALS	-40 + 100 °C
FLUID OPERATING TEMPERATURE RANGE WITH FPM SEALS (VITON)	-20 + 170 °C
HYDRAULIC FLUID	MINERAL OIL
CONTAMINATION CLASS ISO 4406	18/15 (>200 BAR), 19/16 (<200 BAR)
CONTAMINATION CLASS NAS 1638	9 (>200 BAR), 10 (<200 BAR)
ACHIEVED WITH FILTER $\beta_x=75$	15 μ M (>200 BAR), 25 μ M (<200 BAR)

**DEFINITION OF ROTATION DIRECTION
LOOKING ON THE DRIVE SHAFT**

COUNTERCLOCKWISE ROTATION

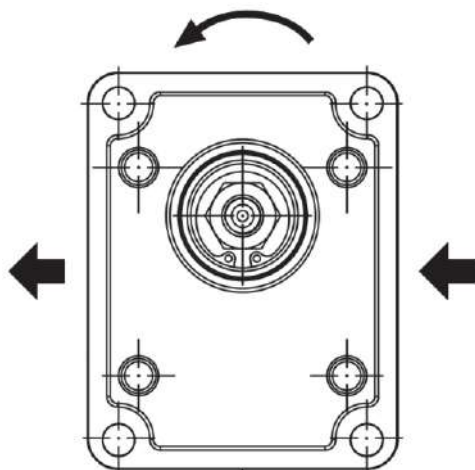

CLOCKWISE ROTATION

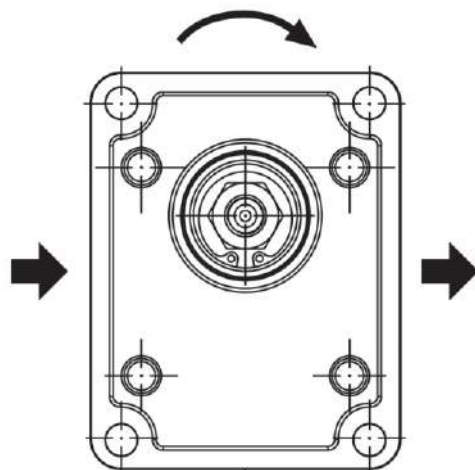

TECHNICAL DATA AND INSTALLATION DIMENSIONS

TYPE	MGP2K4	MGP2K5	MGP2K6	MGP2K8	MGP2K10	MGP2K11	MGP2K12	MGP2K14
DISPLACEMENT, CM ³ /REV	4,5	5,6	6,3	8,2	10,0	11,3	12,5	14,0
DIMENSION A, MM	47,5	49,1	50,2	53,2	56,0	58,0	59,8	62,1
DIMENSION B, MM	23,7	24,6	25,1	26,5	28,0	29,0	29,9	31,1
MAX. CONTINUOUS PRESSURE P ₁ , BAR	250							
MAX. INTERMITTENT PRESSURE P ₂ , BAR	280							
PEAK PRESSURE P ₃ , BAR	300							
MAX. SPEED η_{MAX} , MIN ⁻¹	4000				3500			
MIN. SPEED AT P ₁ ≤ 100 BAR, η_{MIN} , MIN ⁻¹	700					600		
WEIGHT*, KG	2,1	2,1	2,2	2,2	2,3	2,4	2,4	2,6

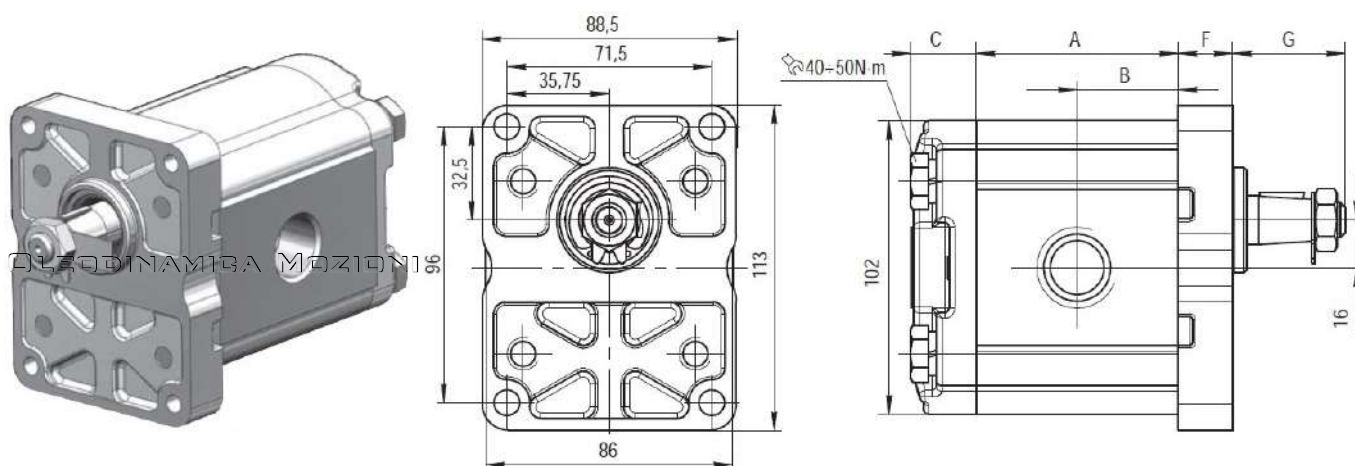

MGP2K10R-G262G

DIMENSION G SEE AT SECTION "DRIVE SHAFTS"
DIMENSION F SEE AT SECTION "MOUNTING FLANGES"
DIMENSION C SEE AT SECTION "REAR COVERS"

* - WEIGHT SPECIFIED FOR PUMPS WITH ALUMINUM COVERS.
WEIGHT FOR PUMPS WITH CAST IRON COATINGS MUST BE CLARIFY.



POMPE AD INGRANAGGI

MGP2K

GEAR PUMPS
GROUP 2

TECHNICAL DATA AND INSTALLATION DIMENSIONS

TYPE	MGP2K15	MGP2K16	MGP2K17	MGP2K19	MGP2K20	MGP2K23	MGP2K25	MGP2K28
DISPLACEMENT, CM ³ /REV	15,0	16,0	17,0	19,0	20,0	22,5	24,8	28,0
DIMENSION A, MM	63,7	65,2	66,9	69,9	71,4	75,3	78,8	83,7
DIMENSION B, MM	31,9	32,6	33,5	35,0	35,7	37,7	39,4	41,9
MAX. CONTINUOUS PRESSURE P ₁ , BAR	250			220	210	190	170	150
MAX. INTERMITTENT PRESSURE P ₂ , BAR	280			250	230	210	190	170
PEAK PRESSURE P ₃ , BAR	300			270	250	230	210	190
MAX. SPEED η_{MAX} , MIN ⁻¹	3500	3000				2500		
MIN. SPEED AT P ₁ ≤ 100 BAR, η_{MIN} , MIN ⁻¹	600			500				
WEIGHT*, KG	2,6	2,7	2,7	2,8	2,8	3,0	3,2	3,4

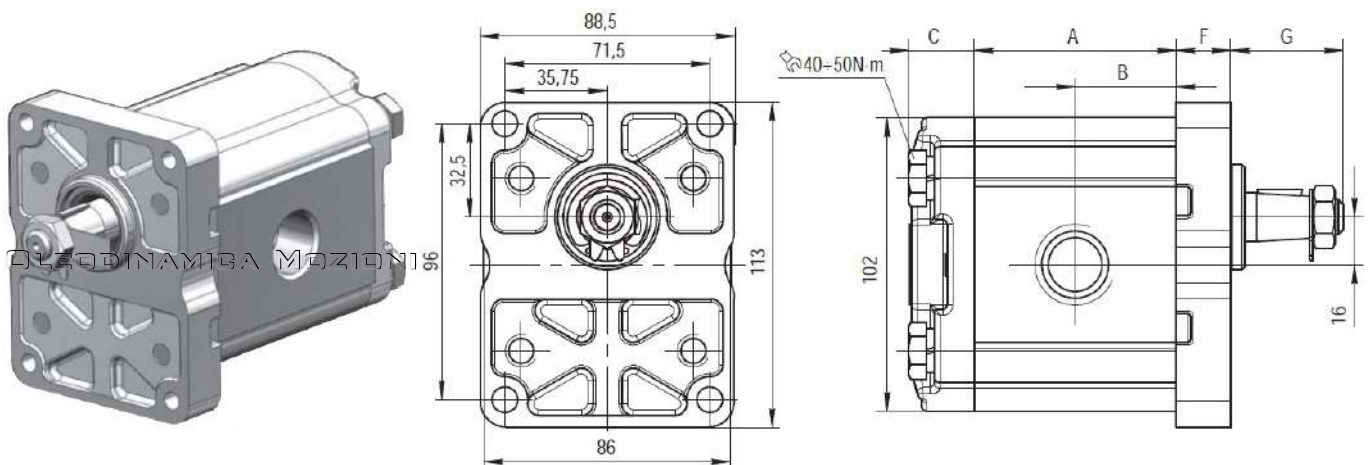







MGP2K10R-G262G

DIMENSION G SEE AT SECTION "DRIVE SHAFTS"
 DIMENSION F SEE AT SECTION "MOUNTING FLANGES"
 DIMENSION C SEE AT SECTION "REAR COVERS"

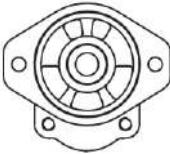
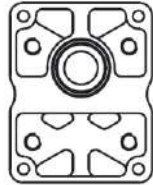
* - WEIGHT SPECIFIED FOR PUMPS WITH ALUMINUM COVERS.
 WEIGHT FOR PUMPS WITH CAST IRON COATINGS MUST BE CLARIFY.

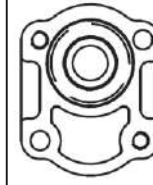
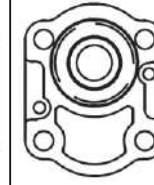
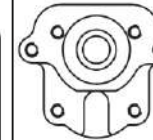
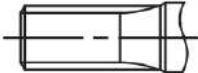
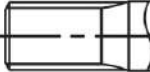
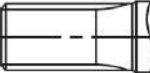
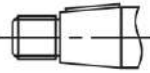
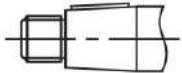
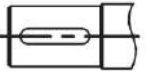
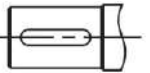
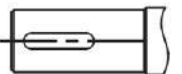

COMBINATIONS OF MOUNTING FLANGES & SHAFTS

MGP2K	 SAE "A" 2 BOLTS	 EUROPEAN	 GERMAN ø80	 GERMAN 2 BOLTS ø50	 GERMAN 2 BOLTS ø52	 GERMAN 4 BOLTS ø52	 FOR PERKINS MOTOR
 SAE A SPLINED (9 TEETH)	B2 31 B2 32						
 SAE A SPLINED (10 TEETH)	B3 31 B3 32						
 SAE A SPLINED (11 TEETH)	B4 31 B4 32						
 EUROPEAN TAPERED 1:8		G2 61 G2 62					G2 21
 GERMAN TAPERED 1:5			F2 81	F2 91 F2 92			
 SAE "A" STRAIGHT ø15,87	H2 31 H2 32	H2 61 H2 62					
 SAE "A" STRAIGHT ø19,05	H8 31 H8 32						
 SAE "A" STRAIGHT ø19,05 LENGTH	H9 31 H9 32						
 TANG DRIVE					K3 93 K3 94	K3 95	
 TANG DRIVE				K4 91 K4 92			
 DIN 5482 SPLINED (9 TEETH)		I2 61 I2 62	I2 81	I2 91 I2 92			

THIS COMBINATIONS OF MOUNTING FLANGES AND SHAFTS ARE USED TO SERIAL PRODUCTION. THE OTHER COMBINATIONS AND DATE OF PRODUCTION, BEFORE ORDERING CLARIFY WITH THE MANUFACTURER.

SEE ALSO: MGP1K
MGP2.5K, MGP3K

DRIVE SHAFTS

MAX. TORQUE 100 N·M

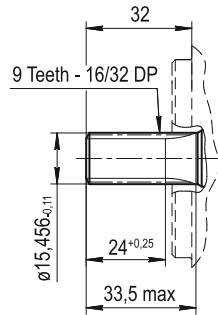

B2 – SAE A SPLINED (9 TEETH)

MAX. TORQUE 130 N·M

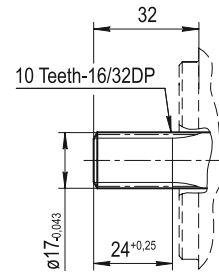

B3 – SAE A SPLINED (10 TEETH)

MAX. TORQUE 170 N·M

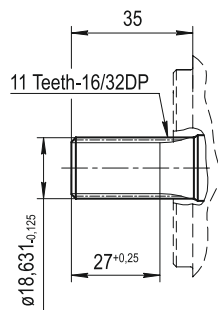

B4 – SAE A SPLINED (11 TEETH)

MAX. TORQUE 140 N·M

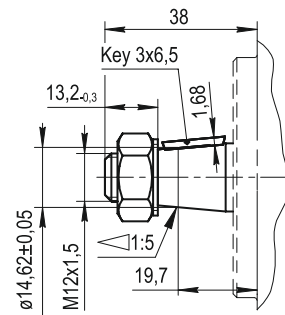

F2 – GERMAN TAPERED 1:5

MAX. TORQUE 140 N·M

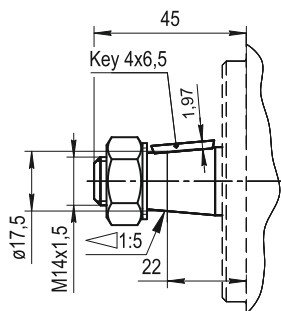

F6 – GERMAN TAPERED 1:5

MAX. TORQUE 140 N·M

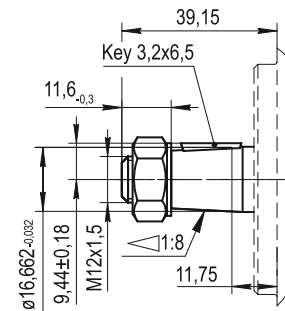

G2 – EUROPEAN TAPERED 1:8

MAX. TORQUE 140 N·M

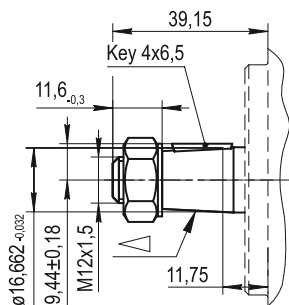

G6 – EUROPEAN TAPERED 1:8

DRIVE SHAFTS

MAX. TORQUE 70 N·M

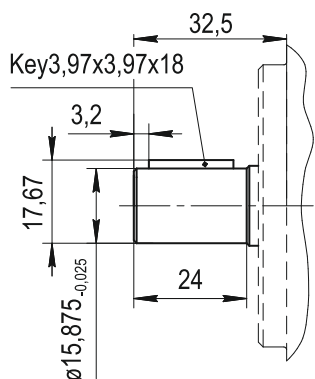

H2 - SAE A STRAIGHT $\varnothing 15,87$

MAX. TORQUE 100 N·M

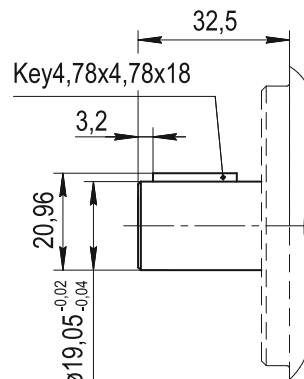

H8 - SAE A STRAIGHT $\varnothing 19,05$

MAX. TORQUE 140 N·M

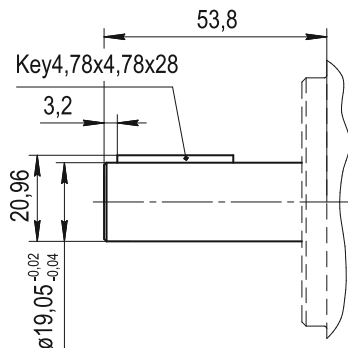

**H9 - SAE A STRAIGHT
 $\varnothing 19,05$ LENGTH**

MAX. TORQUE 70 N·M

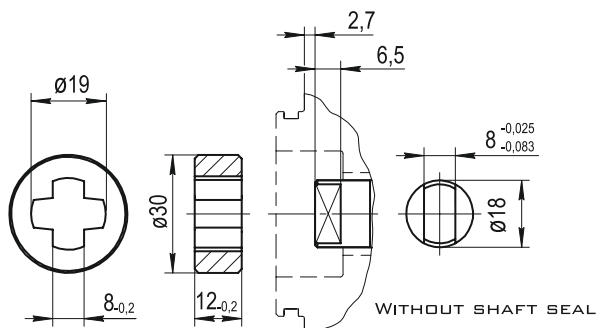

**K3 - TANG DRIVE FOR
ELECTRIC MOTORS**

MAX. TORQUE 70 N·M

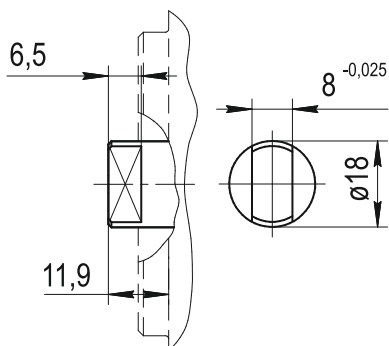

K4 - TANG DRIVE

MAX. TORQUE 70 N·M

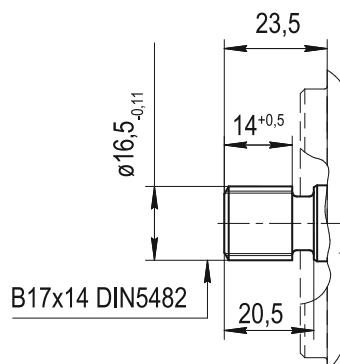

I2 - DIN 5482 SPLINED (9 TEETH)

MOUNTING FLANGES

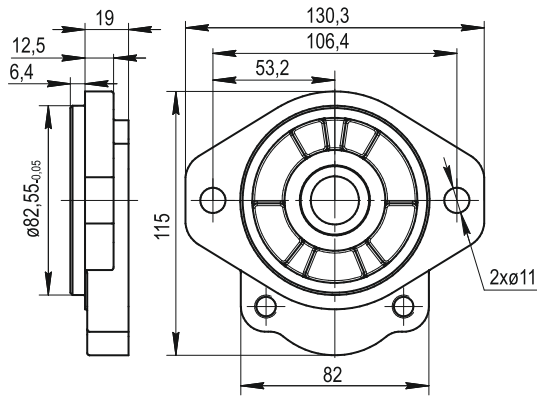

31 - SAE A 2 BOLTS

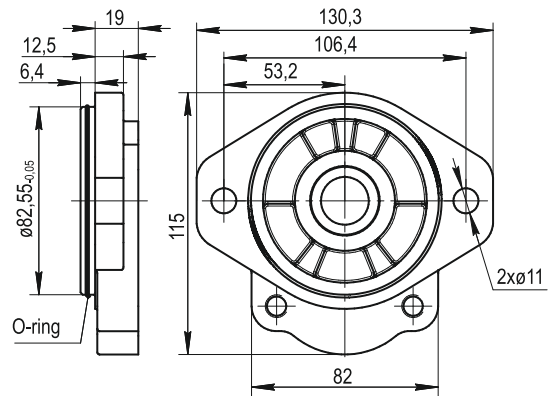

32 - SAE A 2 BOLTS (WITH O-RING)

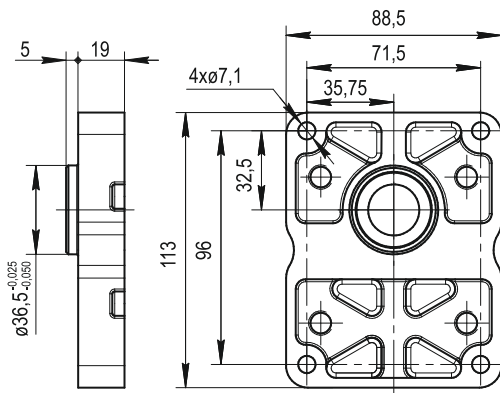

61 - EUROPEAN Ø7,1

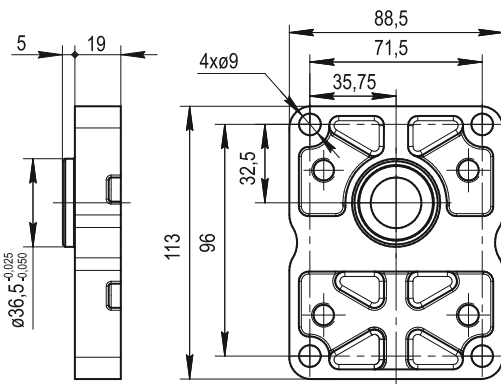

62 - EUROPEAN Ø9

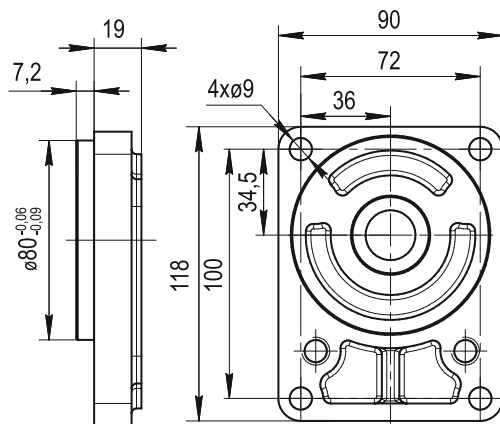

81 - GERMAN Ø80

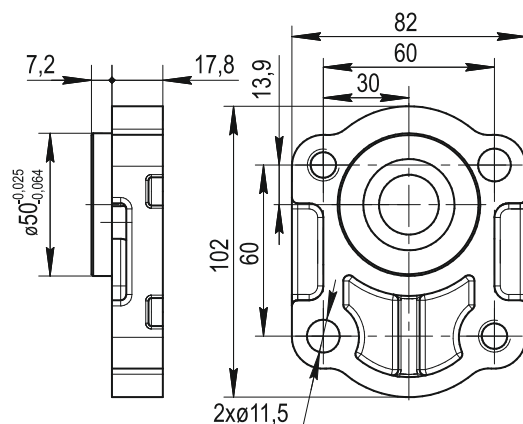

91 - GERMAN 2 BOLTS Ø50

MOUNTING FLANGES

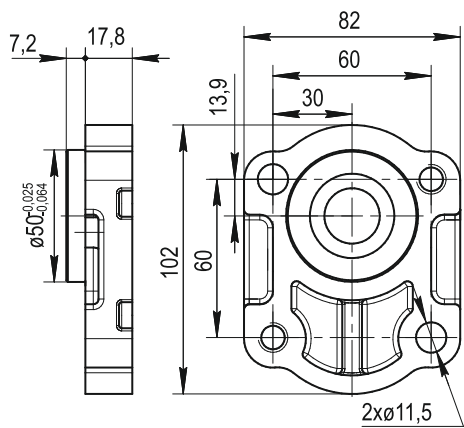

92 - GERMAN 2 BOLTS $\varnothing 50$

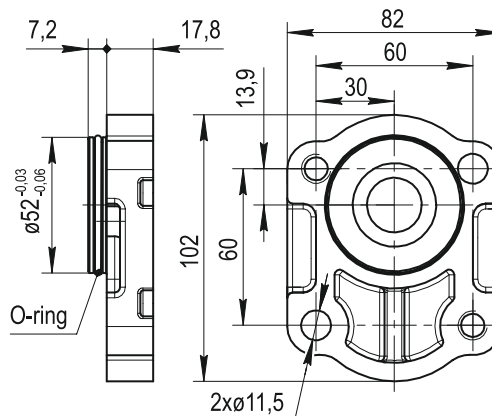

93 - GERMAN 2 BOLTS $\varnothing 52$

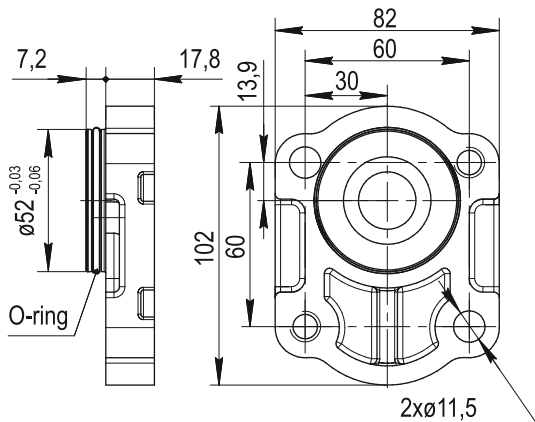

94 - GERMAN 2 BOLTS $\varnothing 52$

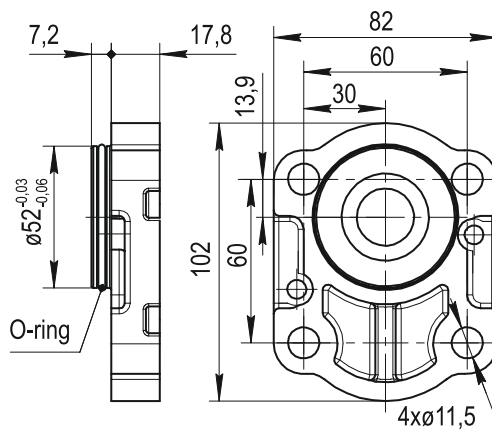

95 - GERMAN 4 BOLTS $\varnothing 52$

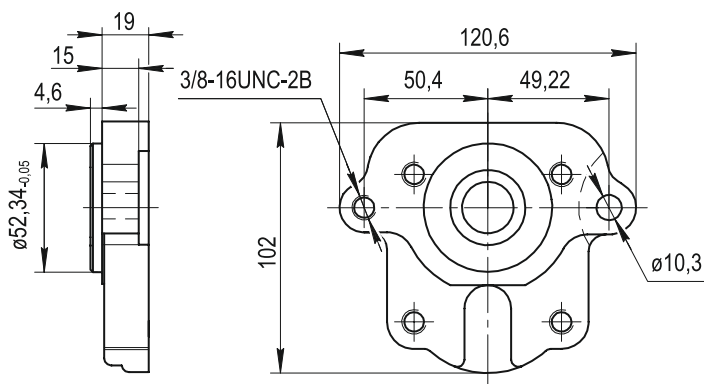

21 - MOUNTING FLANGE
FOR PERKINS MOTOR



PORTS

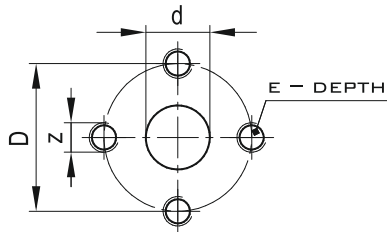

B - EUROPEAN FLANGE

TYPE	INLET				OUTLET			
	D	D	Z	E	D	D	Z	E
MGP2K4÷8	13	30	M6	13	13	30	M6	13
MGP2K10÷28	19	40	M8		14			

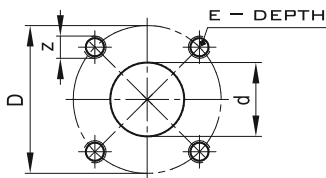

C - GERMAN FLANGE

TYPE	INLET				OUTLET			
	D	D	Z	E	D	D	Z	E
MGP2K4÷28	20	40	M6	13	15	35	M6	13

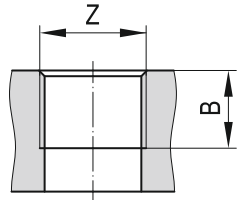

E - METRIC THREADED

TYPE	INLET		OUTLET	
	Z	B	Z	B
MGP2K4÷8	M18x1,5	16	M14x1,5	16
MGP2K10÷12	M22x1,5		M18x1,5	
MGP2K14÷28	M27x2			

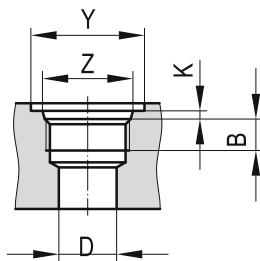

F - SAE THREADED

TYPE	INLET					OUTLET				
	Z	B	K	D	Y	Z	B	K	D	Y
MGP2K4÷8	7/8-14 UNF (SAE #10)	14	2,5	13	32	7/8-14 UNF (SAE #10)	14	2,5	13	32
MGP2K10÷28	1 1/16-12 UN (SAE #12)	16	3,3	20	42					

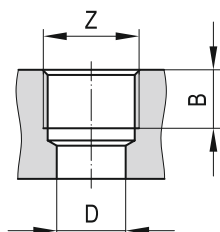

G - GAS THREADED (BSPP)

TYPE	INLET			OUTLET		
	Z	B	D	Z	B	D
MGP2K4÷8	1/2" GAS	16	13	1/2" GAS	16	13
MGP2K10÷28	3/4" GAS	19	20			

REAR COVERS

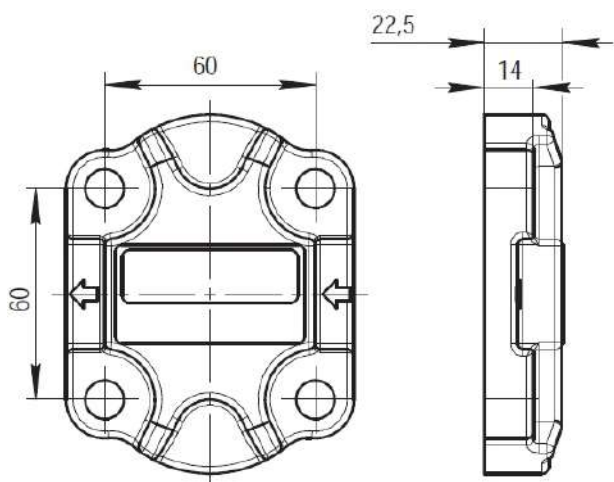

ALUMINIUM

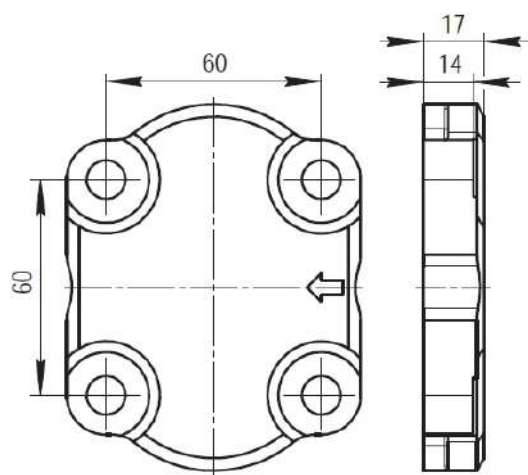

CAST IRON

STANDART REAR COVERS

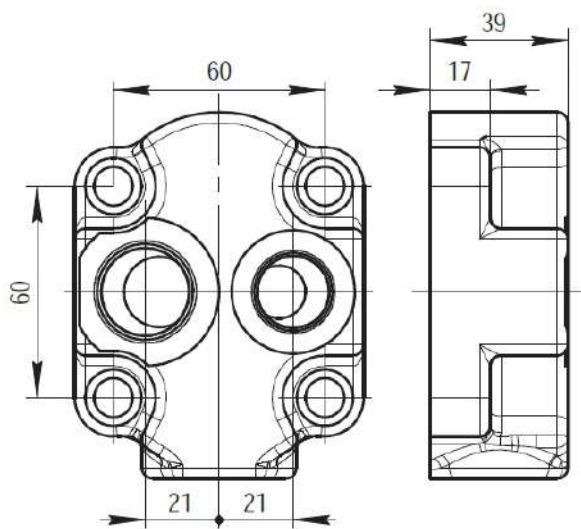

CAST IRON

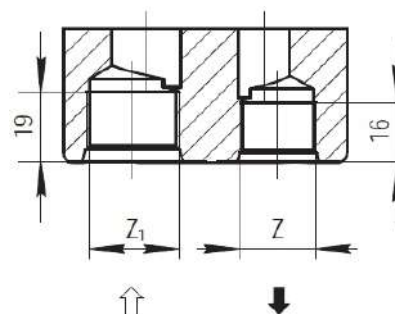

INLET	OUTLET
Z	Z1
M18x1,5	M26x1,5
7/8-14 UNF	1 1/16-12 UN
1/2" GAS	3/4" GAS

1 - REAR COVER WITH THREADED PORTS

OUTRIGGER BEARING VERSION

FOR DRIVE SHAFT:
G2 - L=15,4 MM;
F2 - L=16,9 MM;
H2 - L=22,0 MM

SERVICE LIFE

(L=18 MM,
PULLEY DIAMETER=90 MM):

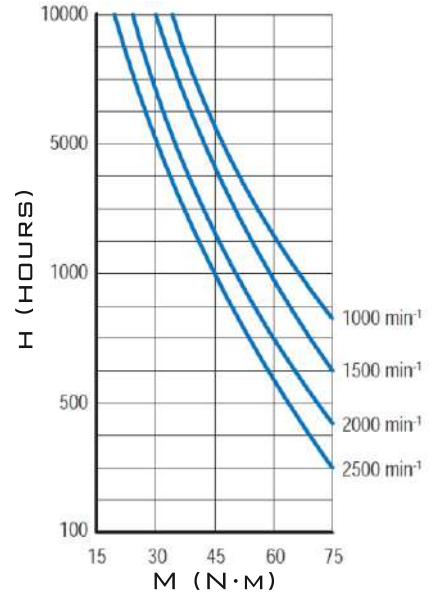
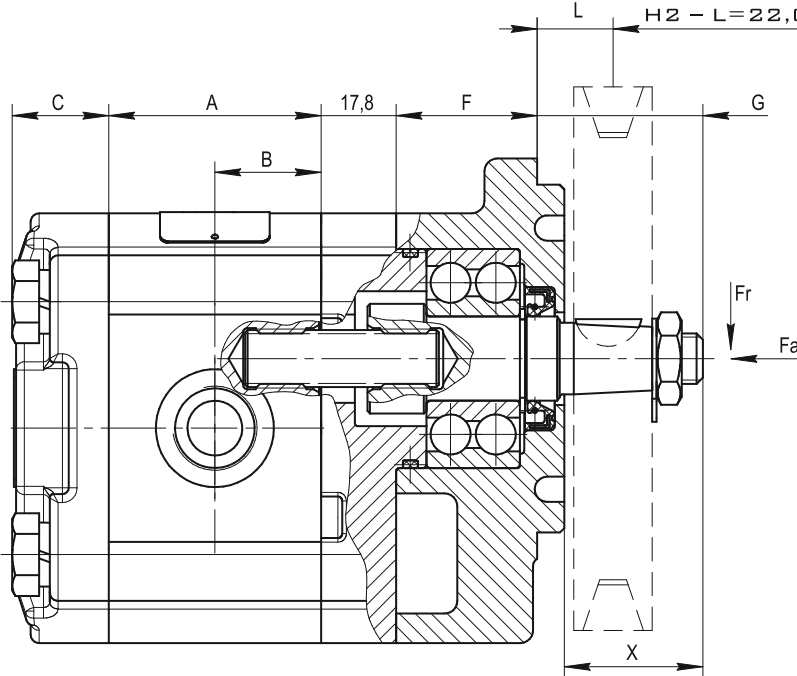

DIMENSION A AND B SEE AT SECTION "TECHNICAL DATA"
DIMENSION G SEE AT SECTION "DRIVE SHAFTS"
DIMENSION F SEE AT SECTION "MOUNTING FLANGES WITH BEARING SUPPORT"
DIMENSION C SEE AT SECTION "REAR COVERS"

WORKING CHARACTERISTIC OF OUTRIGGER BEARING

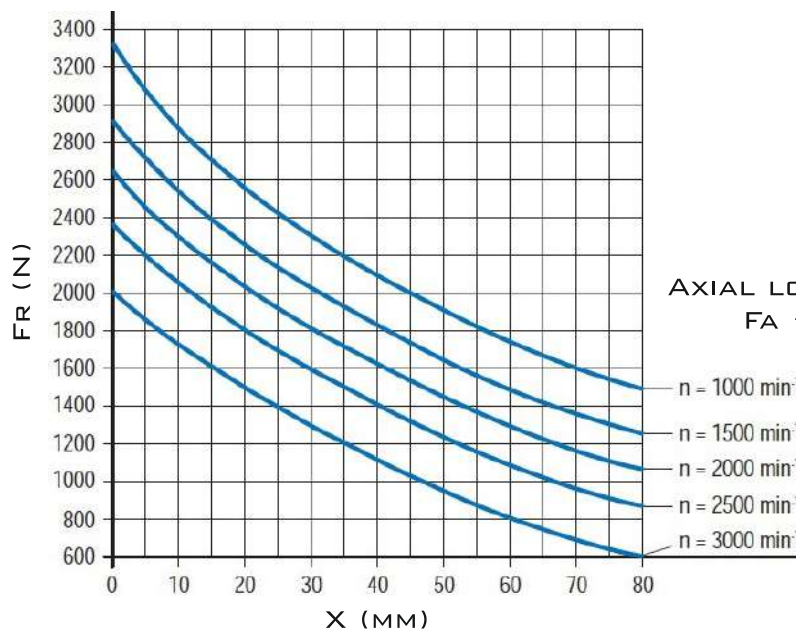

AXIAL LOAD ON SHAFT
 $F_A < F_R \cdot 0,8$

MOUNTING FLANGES WITH BEARING SUPPORT

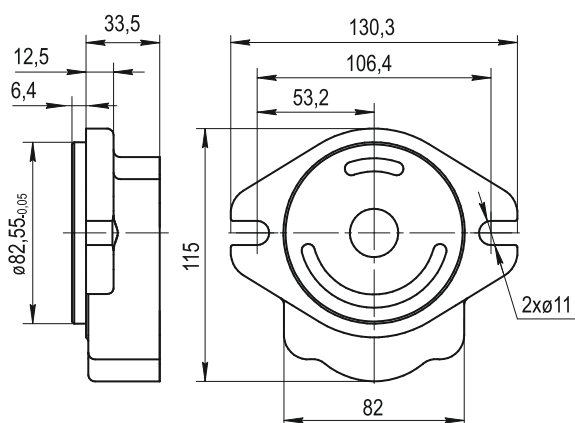

C3 - SAE A

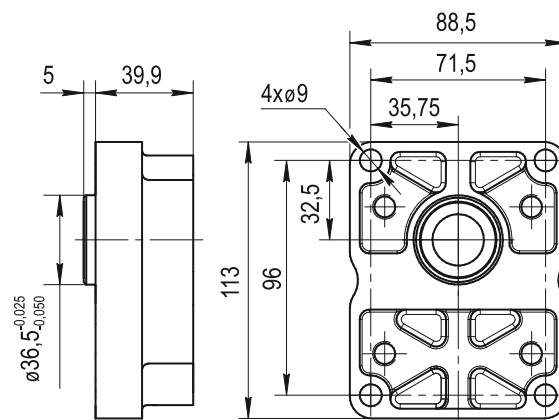

C6 - EUROPEAN

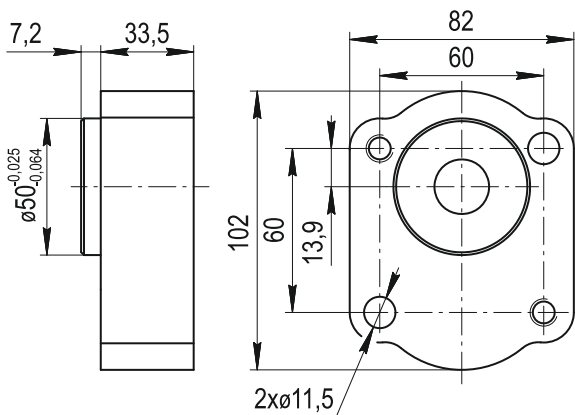

C7 - GERMAN $\varnothing 50$

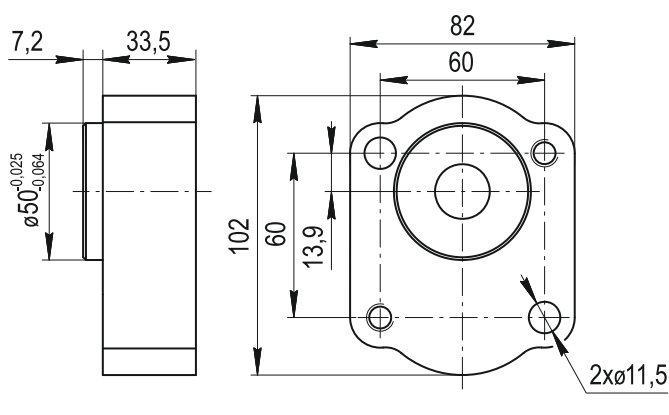

C8 - GERMAN $\varnothing 50$

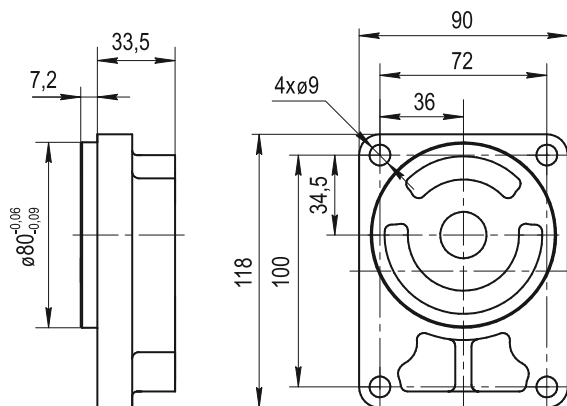

C9 - GERMAN $\varnothing 80$

VERSION WITH VALVE IN REAR COVER

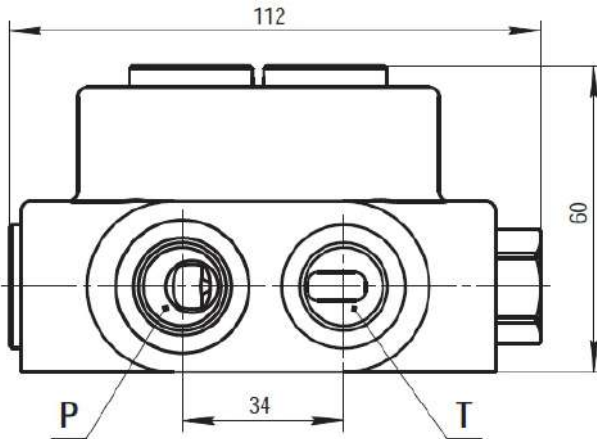

PRESSURE SETTING OF RELIEF VALVE:
20 ÷ 280 BAR

CODE	P	T
E	M20x1,5	M18x1,5
F	7/8-14 UNF	3/4-16 UNF
G	1/2" GAS	3/8" GAS

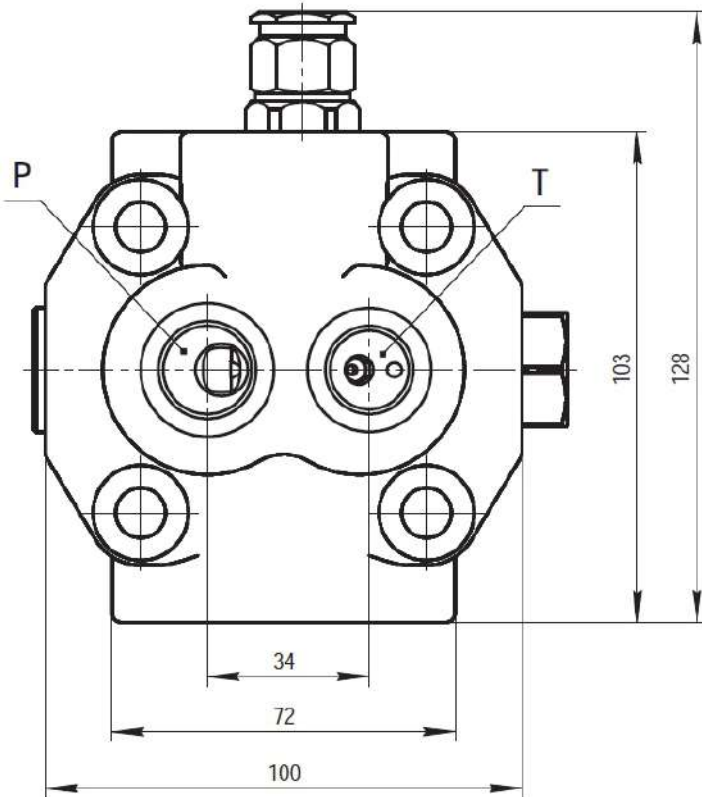

P - PRESSURE LINE
T - RETURN LINE

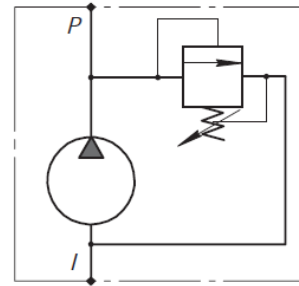

**VR - RETURN TO SUCTION
RELIEF VALVE**

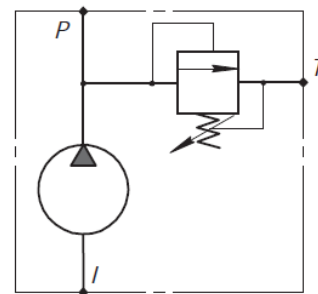

**VR1 - RETURN-TO-TANK
RELIEF VALVE**

VERSION WITH VALVE IN REAR COVER

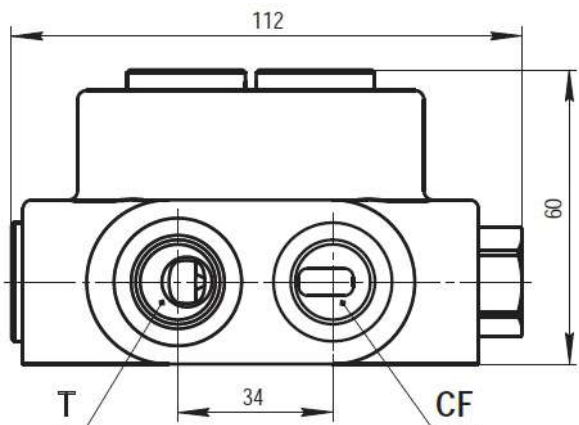

PRESSURE SETTING OF RELIEF VALVE:
20 ÷ 280 BAR

CODE	P	T
E	M18x1,5	M18x1,5
F	3/4-16 UNF	3/4-16 UNF
G	3/8" GAS	3/8" GAS

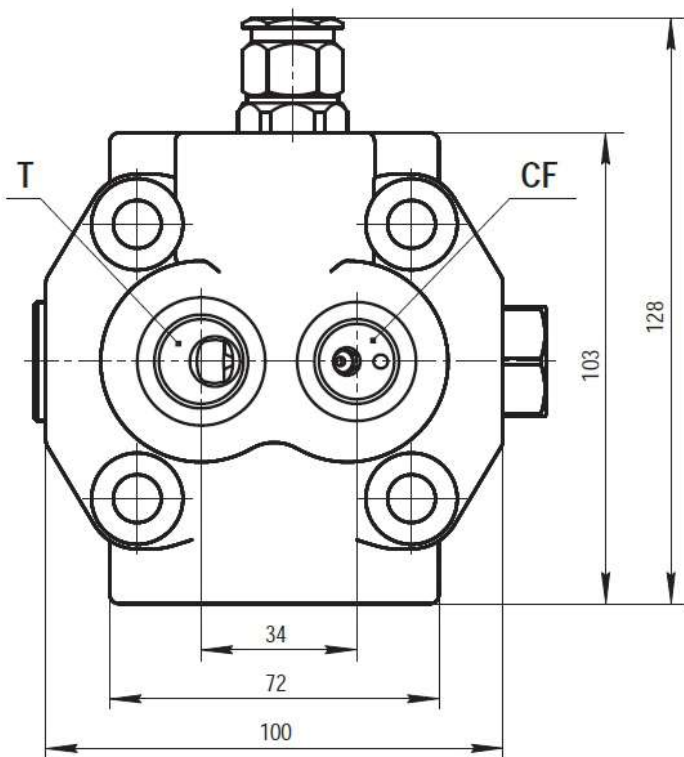

CONSTANT FLOW, L/MIN (± 10%)	1,2	2	4,5	6	8	10
	12	14,5	18	20	23	25

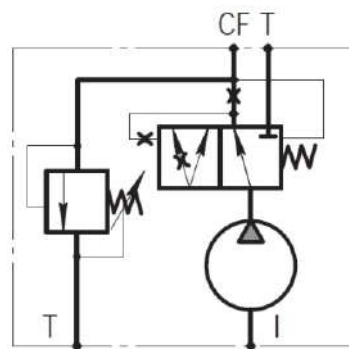

**VQR - CONSTANT FLOW VALVE
WITH A RELIEF VALVE AND
RETURN LINE TO TANK**

CF - CONSTANT FLOW LINE
T - RETURN LINE

VERSION WITH VALVE IN REAR COVER

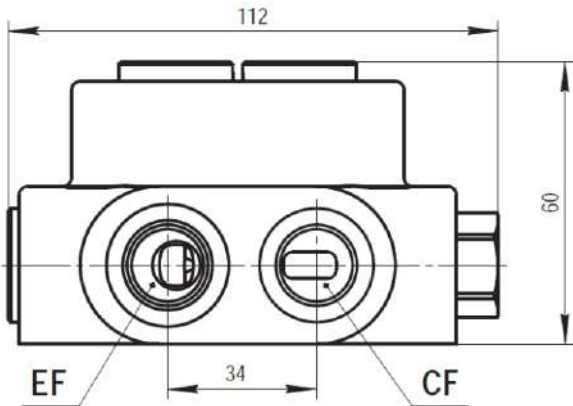

PRESSURE SETTING OF RELIEF VALVE:
20 ÷ 280 BAR

CODE	CF	EF	T
E	M18x1,5	M20x1,5	M18x1,5
F	3/4-16 UNF	7/8-16 UNF	3/4-16 UNF
G	3/8" GAS	1/2" GAS	3/8" GAS

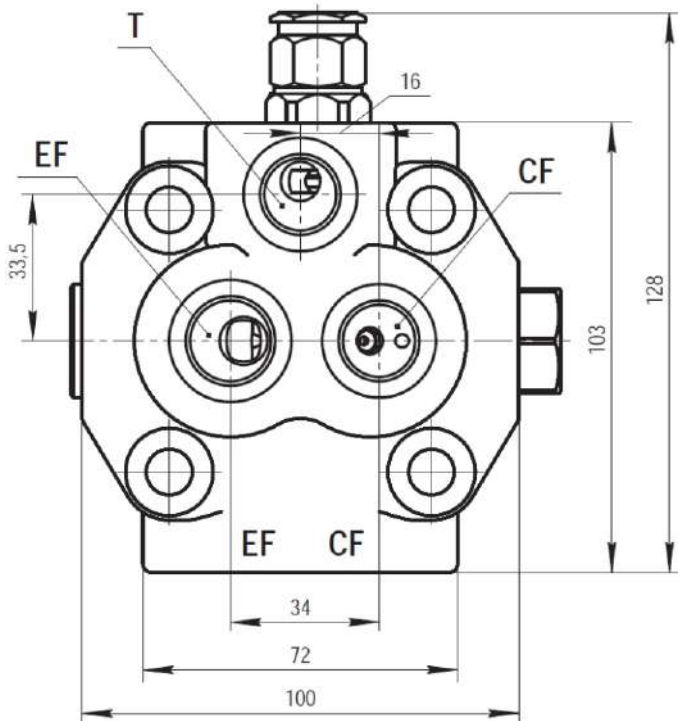

PRIORITY FLOW, L/MIN (± 10%)	1,2	2	4,5	6	8	10
		12	14,5	18	20	23

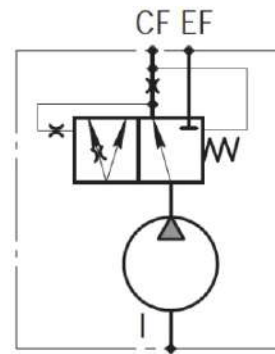

VP - PRIORITY VALVE

CF - PRIORITY FLOW LINE
EF - SECONDARY LINE
T - RETURN LINE

VERSION WITH VALVE IN REAR COVER

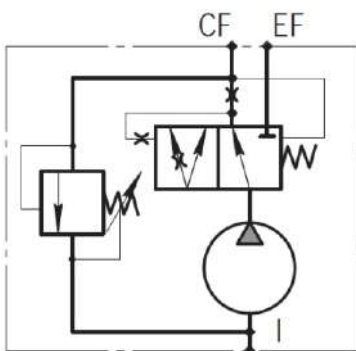

VPR – PRIORITY VALVE WITH A RELIEF VALVE IN THE PRIORITY LINE AND WITH OIL DRAINAGE IN THE SUCTION LINE OF THE PUMP

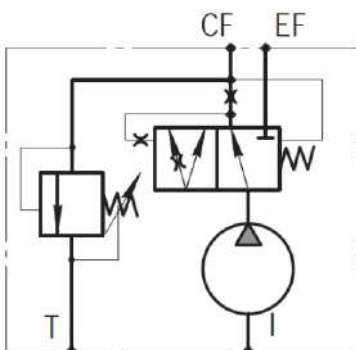

VPRT – PRIORITY VALVE WITH A RELIEF VALVE IN THE PRIORITY LINE AND WITH OIL DRAINAGE IN THE TANK

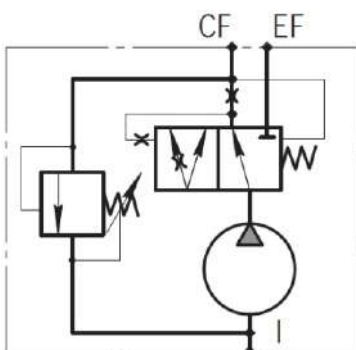

VPRET – PRIORITY VALVE WITH A RELIEF VALVE IN THE SECONDARY LINE AND WITH OIL DRAINAGE IN THE TANK

VERSION WITH VALVE IN REAR COVER

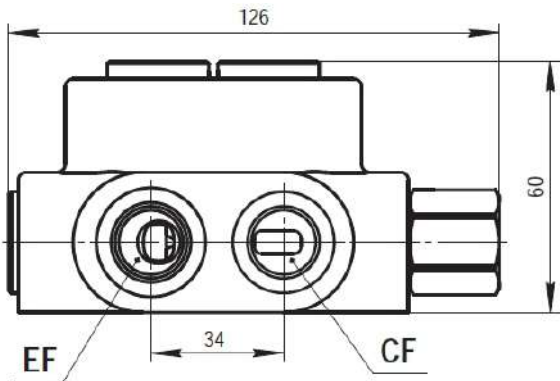

PRESSURE SETTING OF RELIEF VALVE:
20 ÷ 280 BAR

CODE	CF	EF	T	LS
E	M18x1,5	M20x1,5	M18x1,5	M14x1,5
F	3/4-16 UNF	7/8-16 UNF	3/4-16 UNF	7/16-20 UNF
G	3/8" GAS	1/2" GAS	3/8" GAS	1/4" GAS

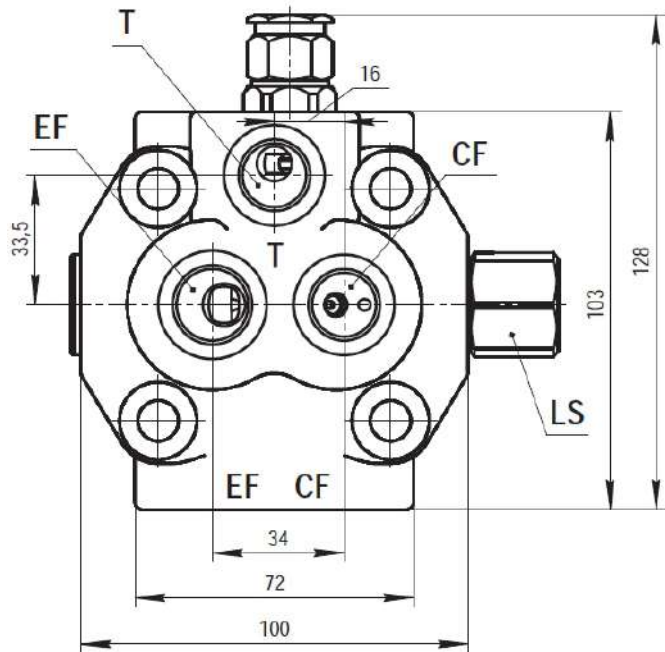

LS SIGNAL, BAR	4	7	10
----------------	---	---	----

CF - PRIORITY FLOW LINE
EF - SECONDARY LINE
LS - SIGNAL LINE
T - RETURN LINE

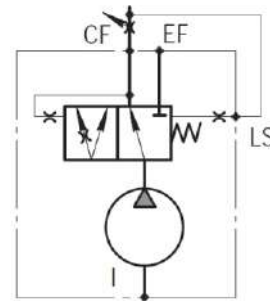

VPLS - PRIORITY VALVE WITH STATIC LS CONTROL

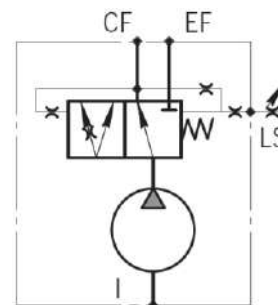

VPLD - PRIORITY VALVE WITH DYNAMIC LS CONTROL

VERSION WITH VALVE IN REAR COVER

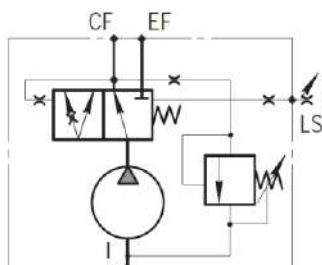

VPLRS – PRIORITY VALVE WITH A RELIEF VALVE IN THE PRIORITY LINE AND WITH OIL DRAINAGE IN THE SUCTION LINE OF THE PUMP

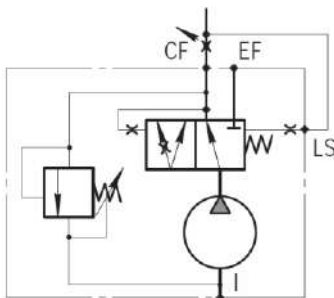

VPLRD – PRIORITY VALVE WITH A RELIEF VALVE IN THE PRIORITY LINE AND WITH OIL DRAINAGE IN THE TANK

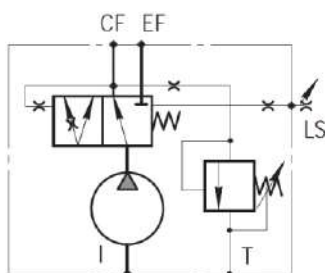

VPLRST – PRIORITY VALVE WITH A RELIEF VALVE IN THE SECONDARY LINE AND WITH OIL DRAINAGE IN THE TANK

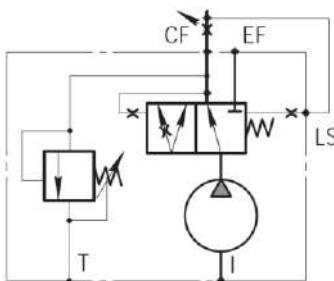

VPLRDT – PRIORITY VALVE WITH A RELIEF VALVE IN THE SECONDARY LINE AND WITH OIL DRAINAGE IN THE TANK

CHARACTERISTIC CURVES

CHARACTERISTIC CURVES CARRIED OUT WITH OIL VISCOSITY AT 16 MM²/SEC,
OIL TEMPERATURE AT 60 °C AND MAX. CONTINUOUS PRESSURES FOR EACH TYPE.

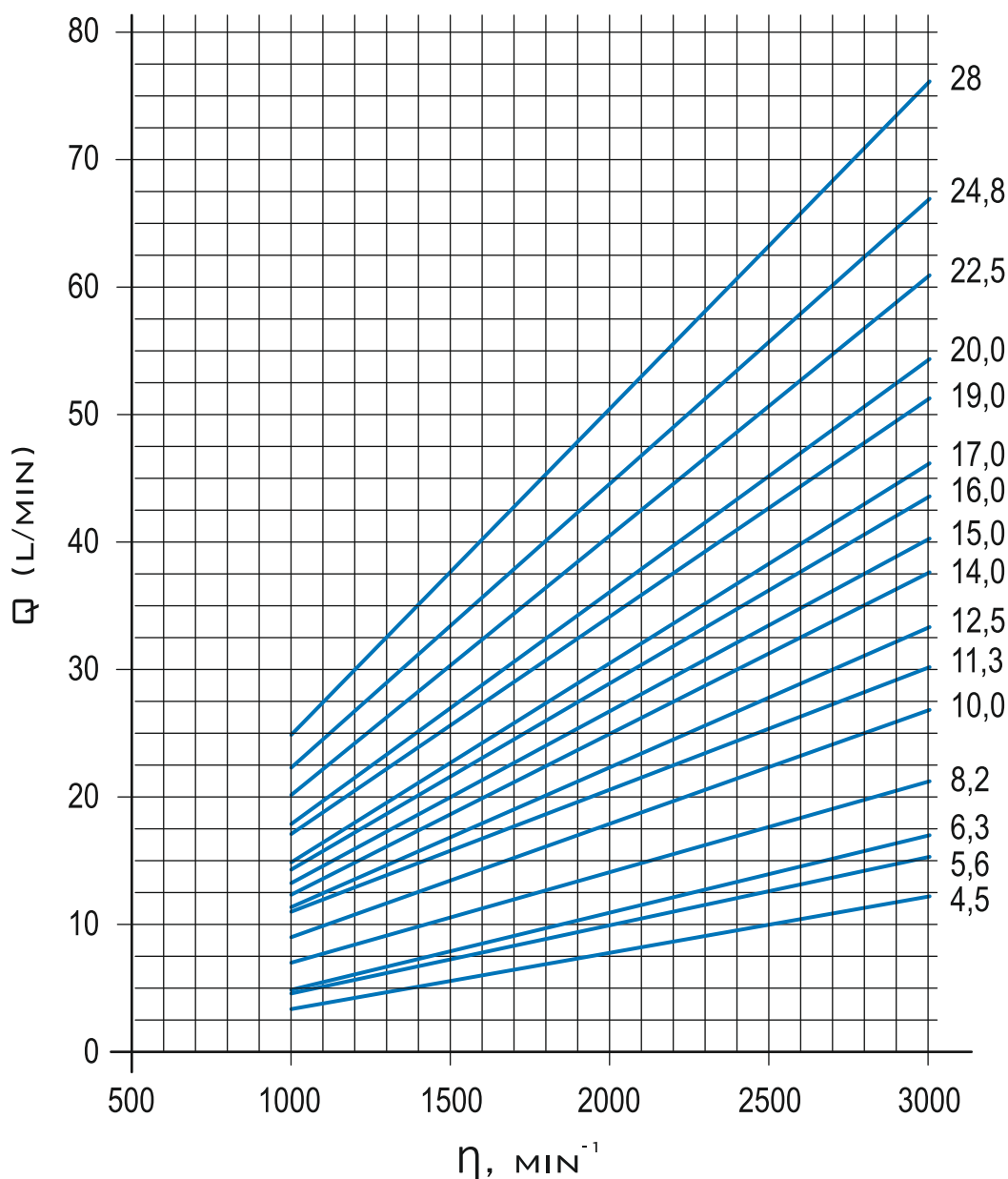

CHARACTERISTIC CURVES

CHARACTERISTIC CURVES CARRIED OUT WITH OIL VISCOSITY AT 16 MM²/SEC AND OIL TEMPERATURE AT 60 °C.

MGP2K4

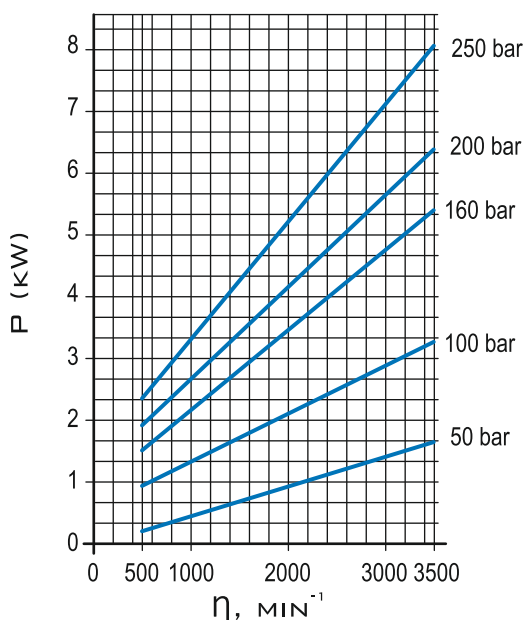

MGP2K5

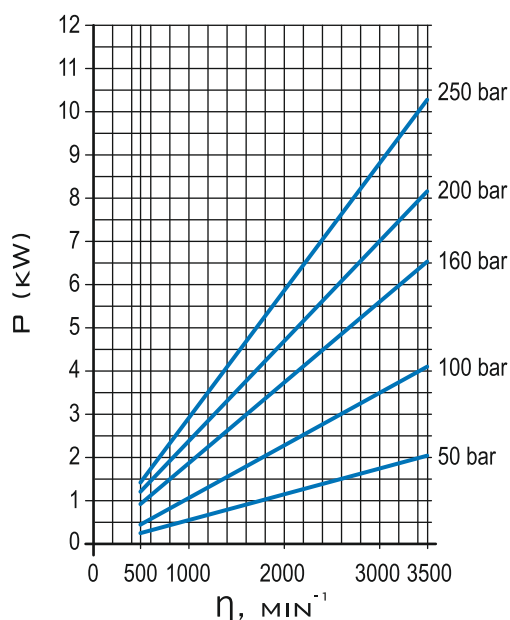

MGP2K6

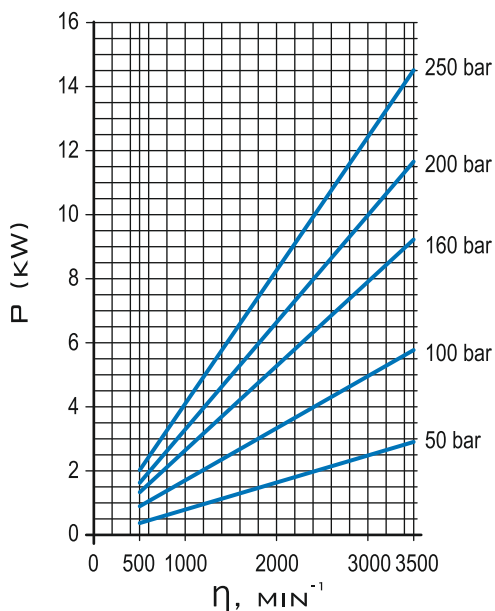

MGP2K8

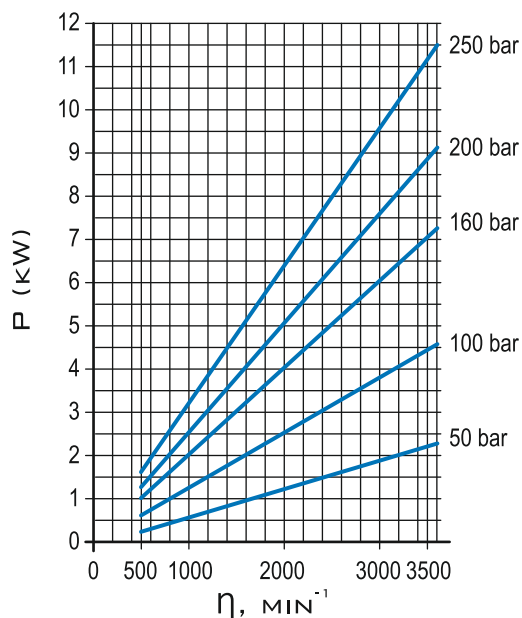



CHARACTERISTIC CURVES

CHARACTERISTIC CURVES CARRIED OUT WITH OIL VISCOSITY AT 16 MM²/SEC AND OIL TEMPERATURE AT 60 °C.

MGP2K10

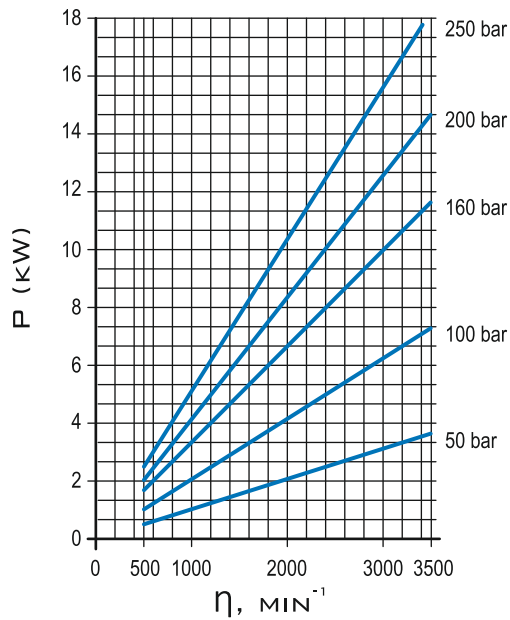

MGP2K11

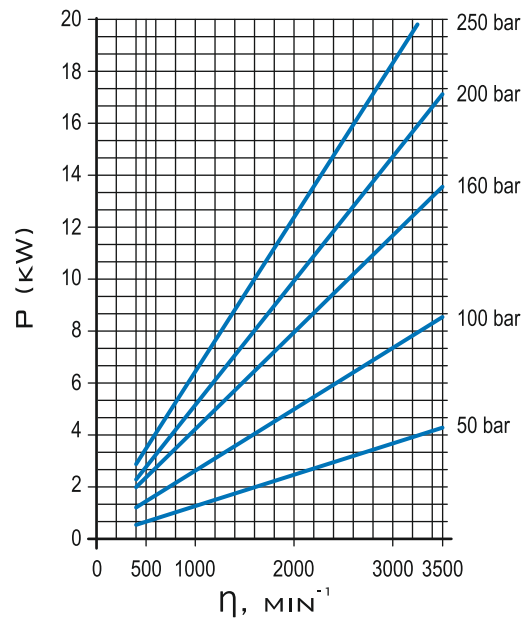

MGP2K12

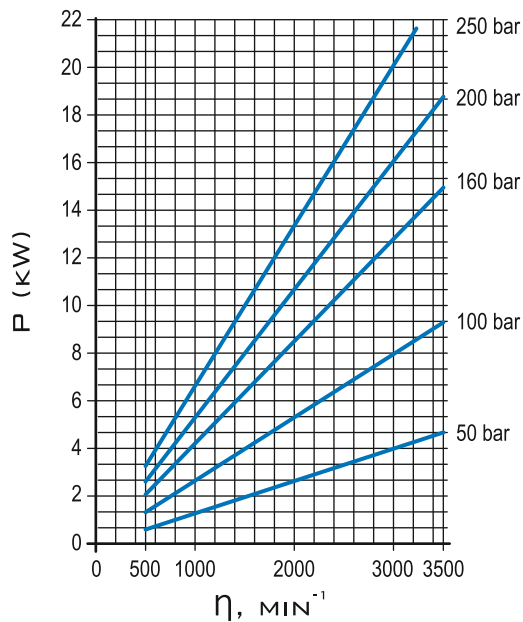

MGP2K14

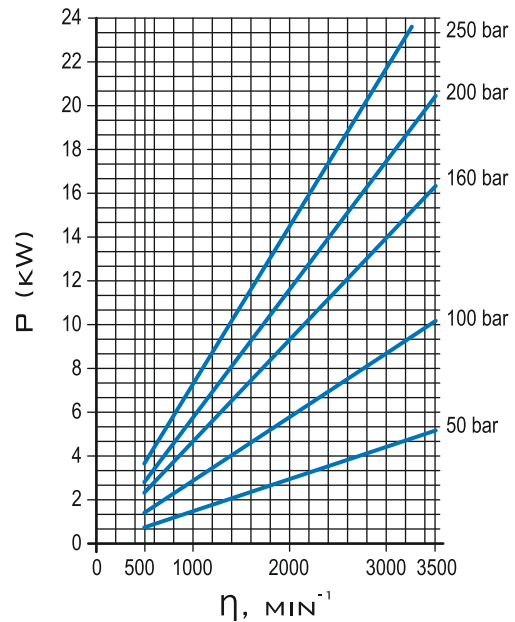

CHARACTERISTIC CURVES

CHARACTERISTIC CURVES CARRIED OUT WITH OIL VISCOSITY AT 16 MM²/SEC AND OIL TEMPERATURE AT 60 °C.

MGP2K15

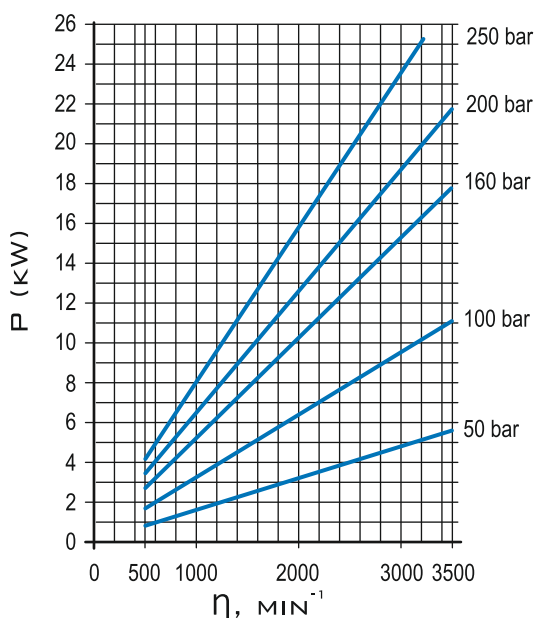

MGP2K16

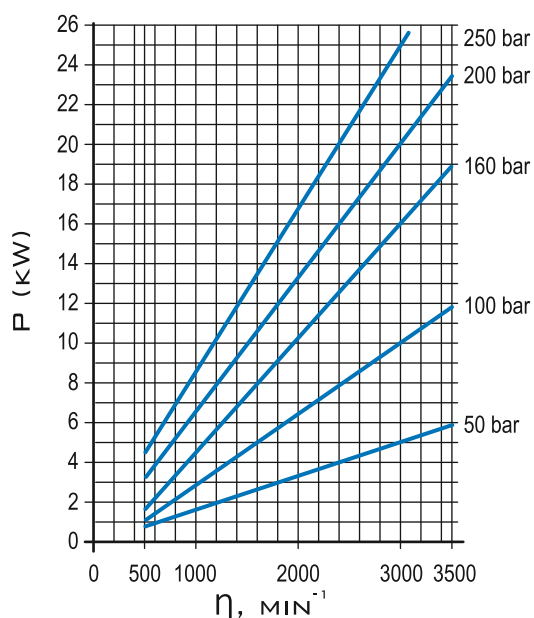

MGP2K17

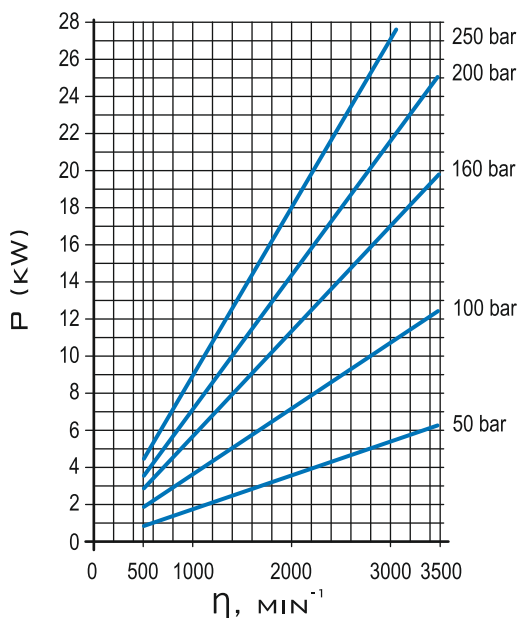

MGP2K19

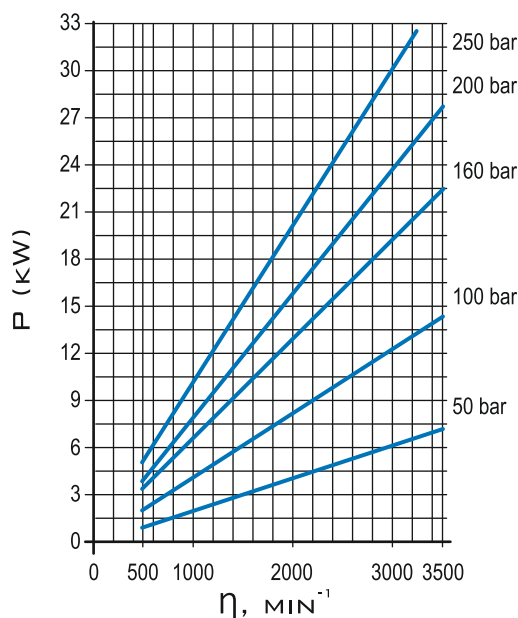



CHARACTERISTIC CURVES

CHARACTERISTIC CURVES CARRIED OUT WITH OIL VISCOSITY AT 16 MM²/SEC AND OIL TEMPERATURE AT 60 °C.

MGP2K20

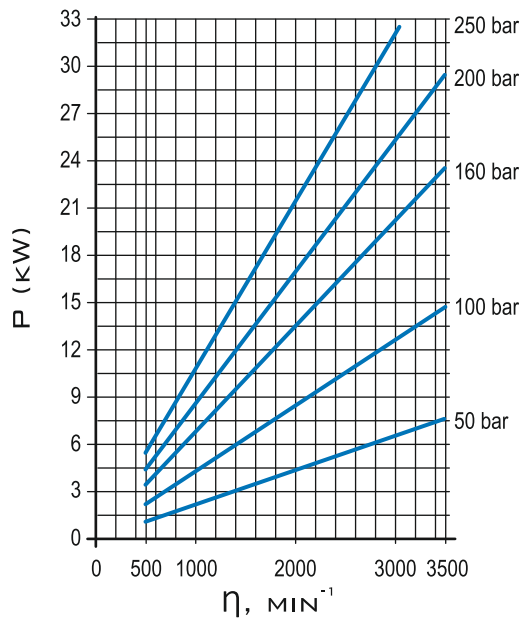

MGP2K23

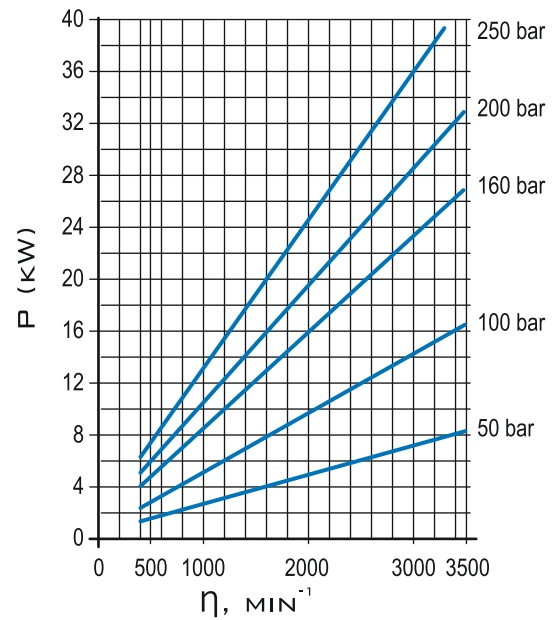

MGP2K25

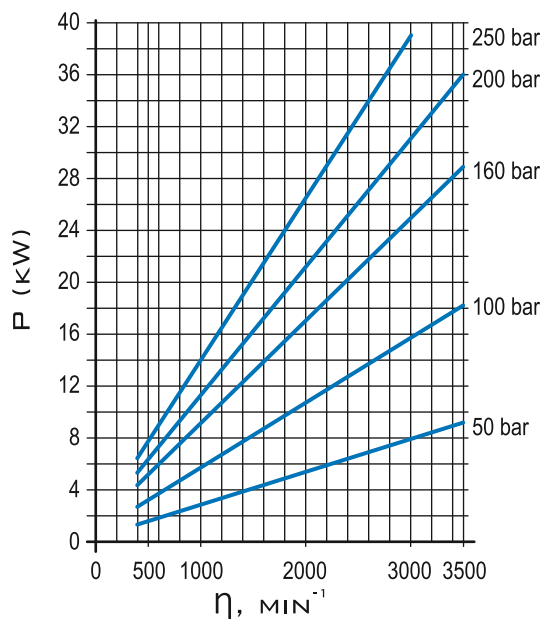

MGP2K28

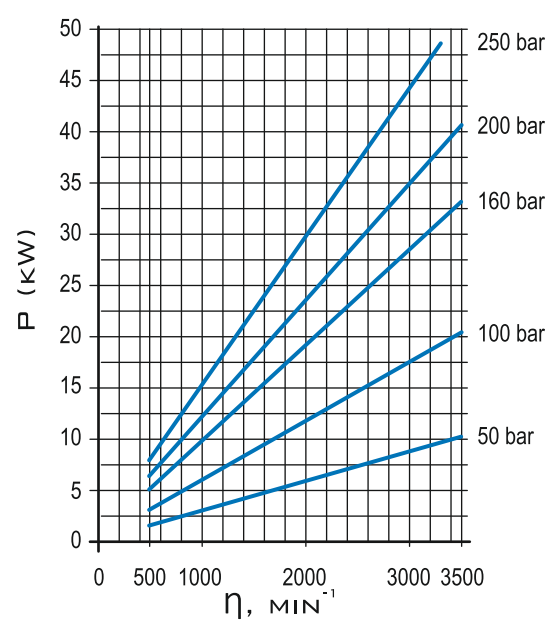

INSTRUCTIONS OF ROTATION CHANGING

PROCESS OF CHANGE DIRECTION SHOWN AT THE EXAMPLE FOR PUMP WITH CLOCKWISE ROTATION.

STEP 1

- UNSCREW AND REMOVE THE SCREWS COMPLETELY.
- PUT THE PUMP MOUNTING FLANGE UP.
- LUBRICATE THE DRIVE SHAFT WITH GREASE TO PREVENT DAMAGE TO THE SHAFT SEAL.

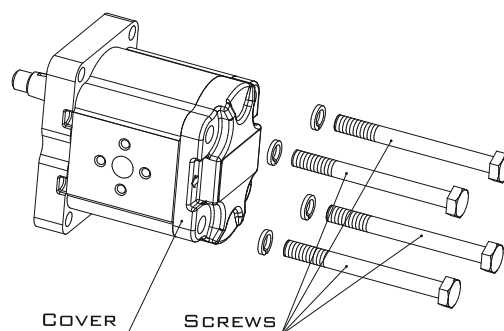

STEP 2

- REMOVE THE MOUNTING FLANGE.
- VERIFY THAT THE COMPENSATION SEAL IS CORRECTLY LOCATED IN THE BODY SEAT.

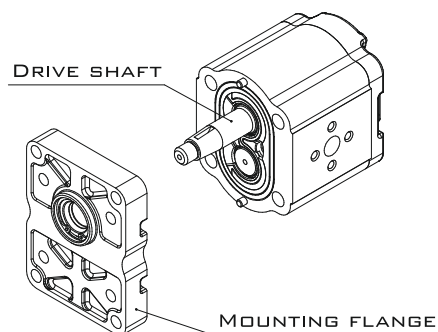

STEP 3

- MARK THE POSITION OF THE BEARING HOUSING (WITH MARKER) RELATIVE TO THE BODY.
- REMOVE THE BEARING HOUSING AND THE DRIVE SHAFT TAKING CARE TO AVOID DRIVEN SHAFT AXIAL SHIFTS.

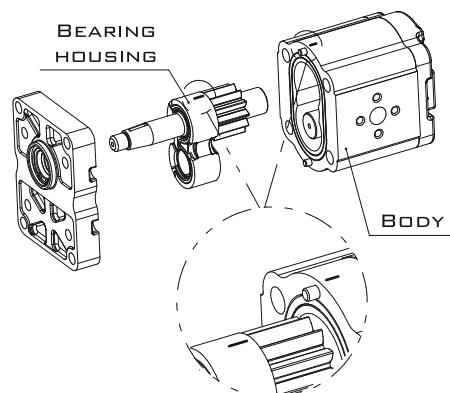

INSTRUCTIONS OF ROTATION CHANGING

PROCESS OF CHANGE DIRECTION SHOWN AT THE EXAMPLE FOR PUMP WITH CLOCKWISE ROTATION.

STEP 4

- DRAW OUT THE DRIVEN SHAFT FROM ITS HOUSING.
- RE-LOCATE THE DRIVEN SHAFT IN THE POSITION PREVIOUSLY OCCUPIED BY THE DRIVE SHAFT.

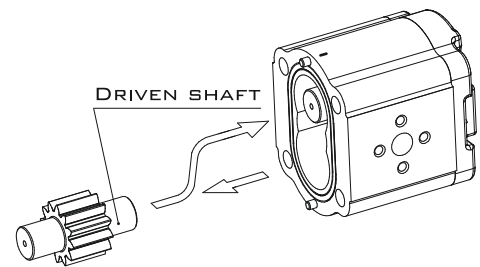

STEP 5

- RE-LOCATE THE DRIVE SHAFT IN THE POSITION PREVIOUSLY OCCUPIED BY THE DRIVEN SHAFT.

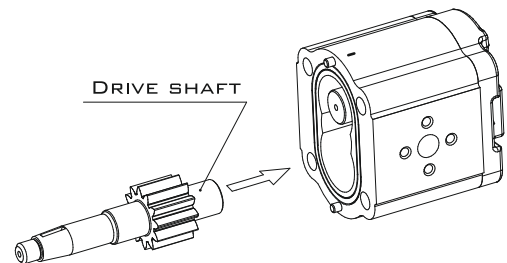

STEP 6

- REPLACE THE BEARING HOUSING TAKING CARE THAT:
- MARKS SHALL BE LOCATED AS IN THE PICTURE.
- COMPENSATION SEAL AND ANTI-EXTRUSION PLATE ARE CORRECTLY LOCATED.

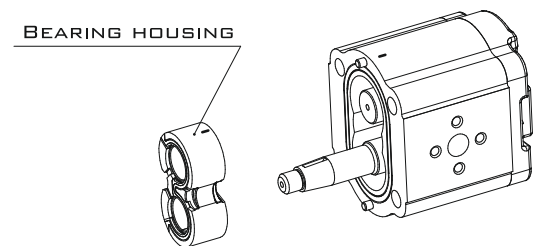

STEP 7

- CLEAN BODY AND MOUNTING FLANGE.
- REFIT THE MOUNTING FLANGE, TURNED 180° FROM ITS ORIGINAL POSITION.
- REPLACE THE CLAMP SCREWS AND TIGHTEN (TORQUE – SEE SECTION “TECHNICAL DATA”).
- CHECK THAT THE SHAFT ROTATES FREELY.

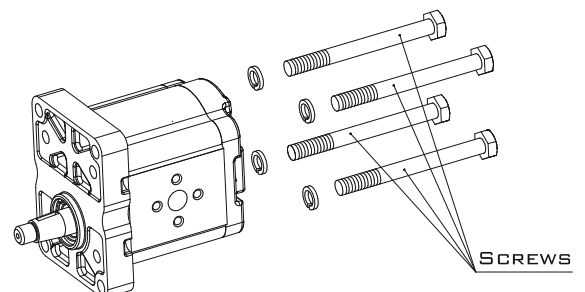



ORDER CODE

MGP 2 K

GROUP 2

SERIES K

- 4=4,5 CM³/REV
- 5=5,6 CM³/REV
- 6=6,3 CM³/REV
- 8=8,2 CM³/REV
- 10=10 CM³/REV
- 11=11,3 CM³/REV
- 12=12,5 CM³/REV
- 14=14 CM³/REV
- 15=15 CM³/REV
- 16=16 CM³/REV
- 17=17 CM³/REV
- 19=19 CM³/REV
- 20=20 CM³/REV
- 23=22,5 CM³/REV
- 25=24,8 CM³/REV
- 28=28 CM³/REV

R=CLOCKWISE ROTATION
L=COUNTERCLOCKWISE ROTATION

- DRIVE SHAFTS:
- B2=SAE A SPLINED (9 TEETH)
 - B3=SAE A SPLINED (10 TEETH)
 - B4=SAE A SPLINED (11 TEETH)
 - F2=GERMAN TAPERED 1:5
 - F6=GERMAN TAPERED 1:5
 - G2=EUROPEAN TAPERED 1:8
 - G6=EUROPEAN TAPERED 1:8
 - H2=SAE A STRAIGHT Ø15,87
 - H8=SAE A STRAIGHT Ø19,05
 - H9=SAE A STRAIGHT Ø19,05 LENGTH
 - K3=TANG DRIVE FOR ELECTRIC MOTORS
 - K4=TANG DRIVE
 - I2=DIN 5482 SPLINED (9 TEETH)

- MOUNTING FLANGES WITH BEARING SUPPORT:
- C3=SAE A
 - C6=EUROPEAN
 - C7=GERMAN Ø50
 - C8=GERMAN Ø50
 - C9=GERMAN Ø80

PORTS CF, EF, T, LS:
E=METRIC THREADED
F=SAE THREADED
G=GAS THREADED

PRESSURE OF RELIEF
VALVE:
20÷280 BAR

PRESSURE OF LS SIGNAL:
4=4 BAR
7=7 BAR
10=10 BAR

TYPE OF VALVE=
SEE PAGES 15-20

NO CODE=ALUMINIUM COVER
F=CAST IRON COVER

NO CODE=NBR SEALS
V=FKM SEALS

PORTS POSITION:
NO CODE=SIDE INLET - SIDE OUTLET
1=BACK INLET - BACK OUTLET

PORTS:
B=EUROPEAN FLANGE
C=GERMAN FLANGE
E=METRIC THREADED
F=SAE THREADED
G=GAS THREADED (BSPP)

MOUNTING FLANGES:
31=SAE A 2 BOLTS
32=SAE A 2 BOLTS (WITH O-RING)
61=EUROPEAN Ø7,1
62=EUROPEAN Ø9
81=GERMAN Ø80
91-92=GERMAN 2 BOLTS Ø50
93-94=GERMAN 2 BOLTS Ø52
95=GERMAN 4 BOLTS Ø52
21=MOUNTING FLANGE FOR
PERKINS MOTOR