

Operation

1. Opening the door/window to separate the magnet from the sensor will send the status of "Open" to the Z-Wave Interface Controller, and the LED will flash once.
2. Closing the door/window to align the magnet with the sensor will send the status of "Closed" to the Z-Wave Interface Controller, and the LED will flash once.
3. Normal operation, the LED will not light.
4. The ZD2102 sensor equipped with tamper switch. If the cover of sensor is removed, the door sensor will report a zone tamper to the Z-Wave Interface Controller, and the LED will go solid.

Federal Communications Commission Statement

This equipment has been tested and found to comply with the limits for a Class B digital device, pursuant to Part 15 of the FCC Rules. These limits are designed to provide reasonable protection against harmful interference in a residential installation. This equipment generates, uses and can radiate radio frequency energy and, if not installed and used in accordance with the instruction, may cause harmful interference to radio communications. However, there is no guarantee that interference will not occur in a particular installation. If this equipment does cause harmful interference to radio or television reception, which can be determined by turning the equipment off and on, the user is encouraged to try and correct the interference by one of the following measures:

- Reorient or relocate the receiving antenna.
- Increase the separation between the equipment and receiver.
- Connect the equipment into an outlet on a circuit different from that to which the receiver is connected.
- Consult the dealer or an experienced radio/TV technician for help.

This device complies with Part 15 of the FCC Rules. Operation is subject to the following two conditions: (1) this device may not cause harmful interference, and (2) this device must accept any interference received, including interference that may cause undesired operation.

FCC Caution: Any changes or modifications not expressly approved by the party responsible for compliance could void the user's authority to operate this equipment.

Limited Warranty

Vision Guarantees that every wireless door/window sensor is free from physical defects in material and workmanship under normal use for one year from the date of purchase. If the product proves defective during this one-year warranty period, Vision will replace it free of charge. Vision does not issue any refunds. This warranty is extended to the original end user purchase only and is not transferable. This warranty does not apply to: (1) damage to units caused by accident, dropping or abuse in handling, or any negligent use; (2) units which have been subject to unauthorized repair, opened, taken apart, or otherwise modified; (3) units not used in accordance with instruction; (4) damages exceeding the cost of the product; (5) transit damage, initial installation costs, removal cost, or reinstallation cost.

For information on additional devices, please visit us at www.visionsecurity.com.tw

ZD 2102 V0 20101013 16B1Z-21001

-3-

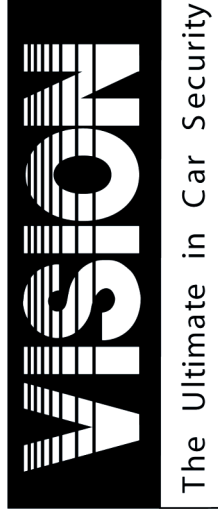

Installation & Operation Manual

ZD 2102 EU
ZD 2102 US
ZD 2102 AU
ZD 2102 JP

Wireless Door/ Window Sensor

Introduction

Thanks for choosing the Vision's wireless door/window sensor of the home security device. This sensor is a Z-Wave enabled device (interoperable, two-way RF mesh networking technology) and is fully compatible with any Z-Wave enabled network. This sensor monitors door/window and send Z-Wave signal when door or window is opened and closed. Every Z-Wave enabled device acts as a signal repeater and multiple devices result in more possible transmission routes which helps eliminate "RF dead-spots".

Product Description and Specification

*** For indoor use only***

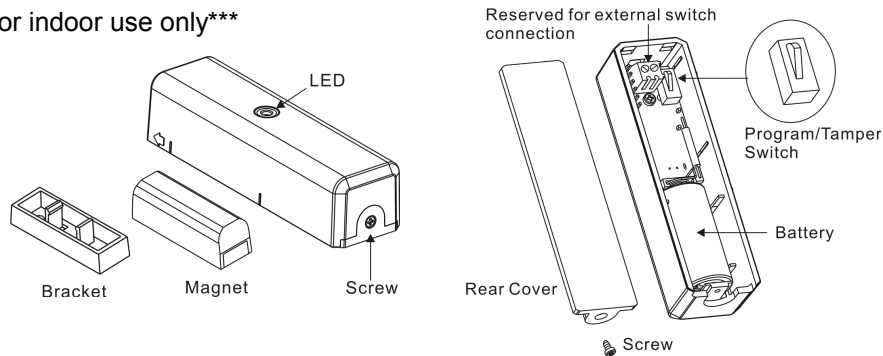

Specification:

Protocol: Z-Wave (ZM3102N)
 Frequency Range:
 868.42MHz (ZD2102EU)
 908.42MHz (ZD2102US)
 921.42MHz (ZD2102AU)
 951-956MHz (ZD2102JP)
 Operating Range: Up to 100 feet line of sight
 Operating Temp.: -15°C~ 60°C (5°F ~140°F)
 Battery: Panasonic CR123A * 1PC

Package Content:

1pc ZD 2012 sensor
 1pc Bracket for Contact Magnet
 1pc Magnet
 2pcs Adhesive tape for Magnet / sensor
 1pc CR123A Lithium Battery
 4pcs Screws for bracket/ sensor
 1pc Installation & Operation manual

Installation

Notice: If you are installing the entire Z-Wave system for the first time, please refer to the installation guide of Z-Wave Interface Controller you have ordered from other manufacturer before installing ZD2102 Door/Window Sensor.

1. Unscrew the screw fastening the rear cover.
2. Slide the rear cover down.
3. Using the screws or adhesive tape to affix the rear cover on the frame along the opening edge of door / window.

4. Using the screws or adhesive tape to affix the rear cover on the frame along the opening edge of door / window.
5. Insert a CR123A battery into the battery compartment, and LED will start to flash slowly, which means the sensor has not yet been "inclusion"
6. **For "Inclusion" operation:** Put the Z-Wave Interface Controller into "inclusion" mode, and following its instruction to add the ZD2102 to your controller. To get in the "inclusion" mode, the distance between sensor and controller is suggested to be in one meter. Press the program switch of ZD2102 for 1 second at least. The LED on the ZD2102 should go solid, if not, please try again.

For "Exclusion" operation: Put the Z-Wave Interface Controller into "exclusion" mode, and following its instruction to delete the ZD2102 to your controller. Press the program switch of ZD2102 for 1 second at least to be excluded.

For "Associations" operation: Put the Z-Wave Interface Controller into "association" mode, and following its instruction to associate the ZD2102 with other device. Please remove the cover of ZD2102 to do association & close back after done. Up to four Z-Wave devices can be associated with ZD2102. ZD2102 will send a simple "on" command to all devices that are associated with it.

7. Slide back the rear cover and screw fastening with the front cover, the LED should go off.
8. Fix the Magnet by using the adhesive tape or fixing screws, locate the Magnet close to the ZD2102 sensor the distance between these two devices should be in 1.9cm.
9. External Switch: If your window need two sensors for fully monitoring. You could use an external switch to connect with the ZD2102 for extending detection. The ZD2102 has 2 normally closed contact terminals. These can be used for additional external switch wired contacts.

