

# 2PS 25

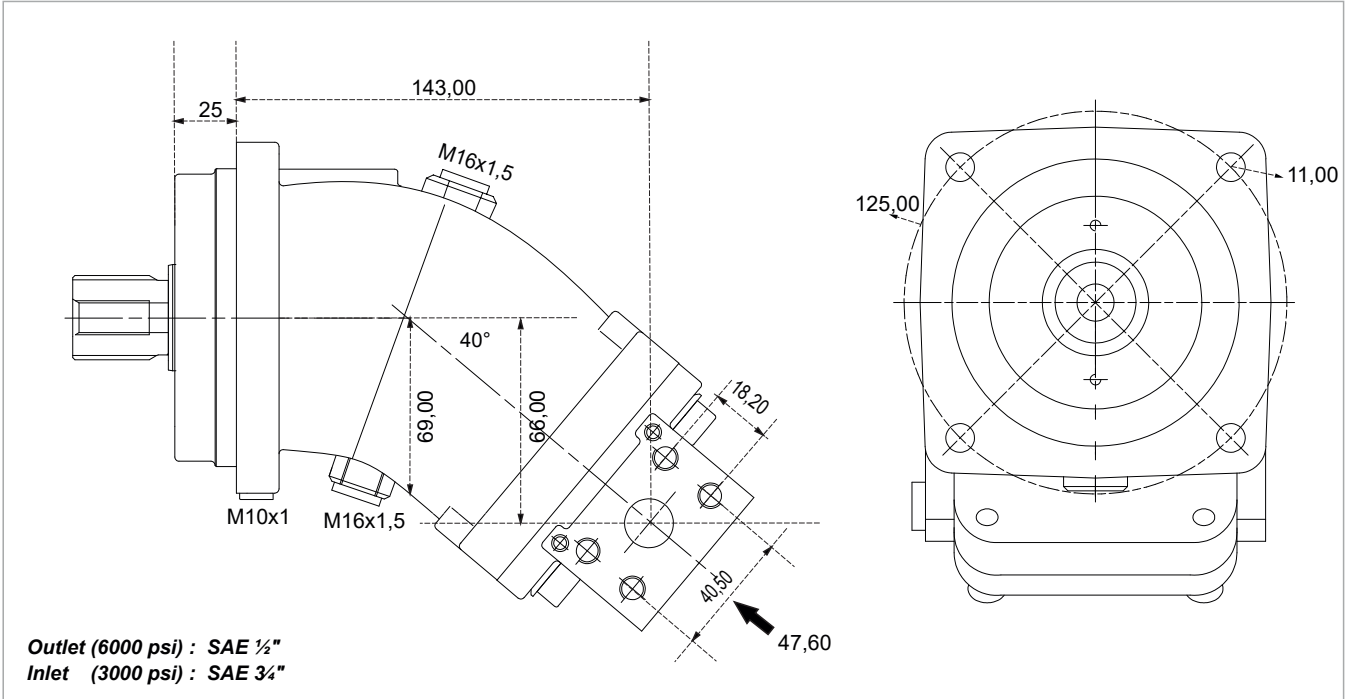

<b>x 1000 rpm</b>	25,00 cc
<b>x 1500 rpm</b>	37,50 cc
<b>Max. Continuous Pump Speed</b>	2500 rpm
<b>Max. Continuous Pressure</b>	400 bar
<b>Max. Peak Pressure</b>	450 bar
<b>Max. Torque at 350 bar</b>	141 Nm
<b>Max. Flow</b>	62,50 l/min.
<b>Min. Pump Temperature</b>	-25 °C
<b>Max. Pump Temperature</b>	110 °C
<b>Weight without accessories</b>	11,50 kg
<b>Weight with accessories</b>	11,80 kg
<b>Rotation</b>	CW-CCW

