

# 2PE 108 - SAE C - 4 BOLT

SAE D 13T-8/16  
SAE C 14T-12/24

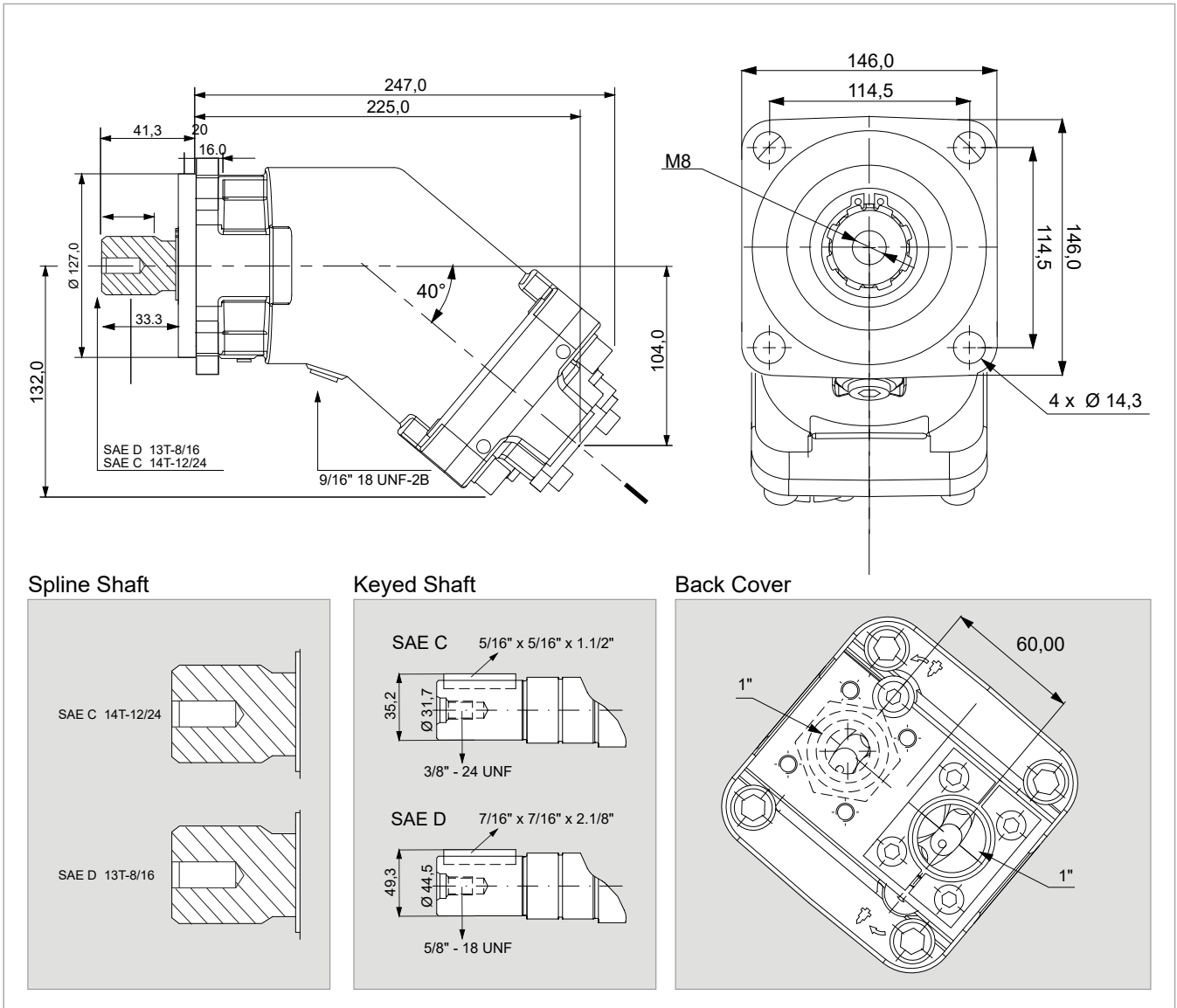

<b>x 1000 rpm</b>	108,40 cc
<b>x 1500 rpm</b>	162,60 cc
<b>Max. Continuous Pump Speed</b>	1700 rpm
<b>Max. Limited Pump Speed</b>	1900 rpm
<b>Max. Continuous Pressure</b>	350 bar
<b>Max. Intermit. Peak Pressure</b>	400 bar
<b>Max. Torque at 350 bar</b>	620 Nm
<b>Weight without inlet fitting</b>	16,50 kg
<b>Weight with inlet fitting</b>	16,90 kg
<b>Rotation</b>	CW-CCW

Flow, Speed, Pressure List of 2PE 108

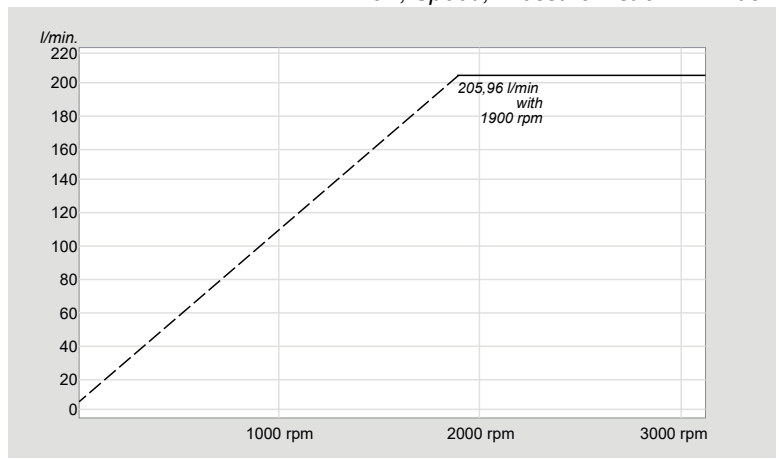

# 2PE 108 - SAE D - 4 BOLT

SAE D 13T-8/16  
SAE C 14T-12/24

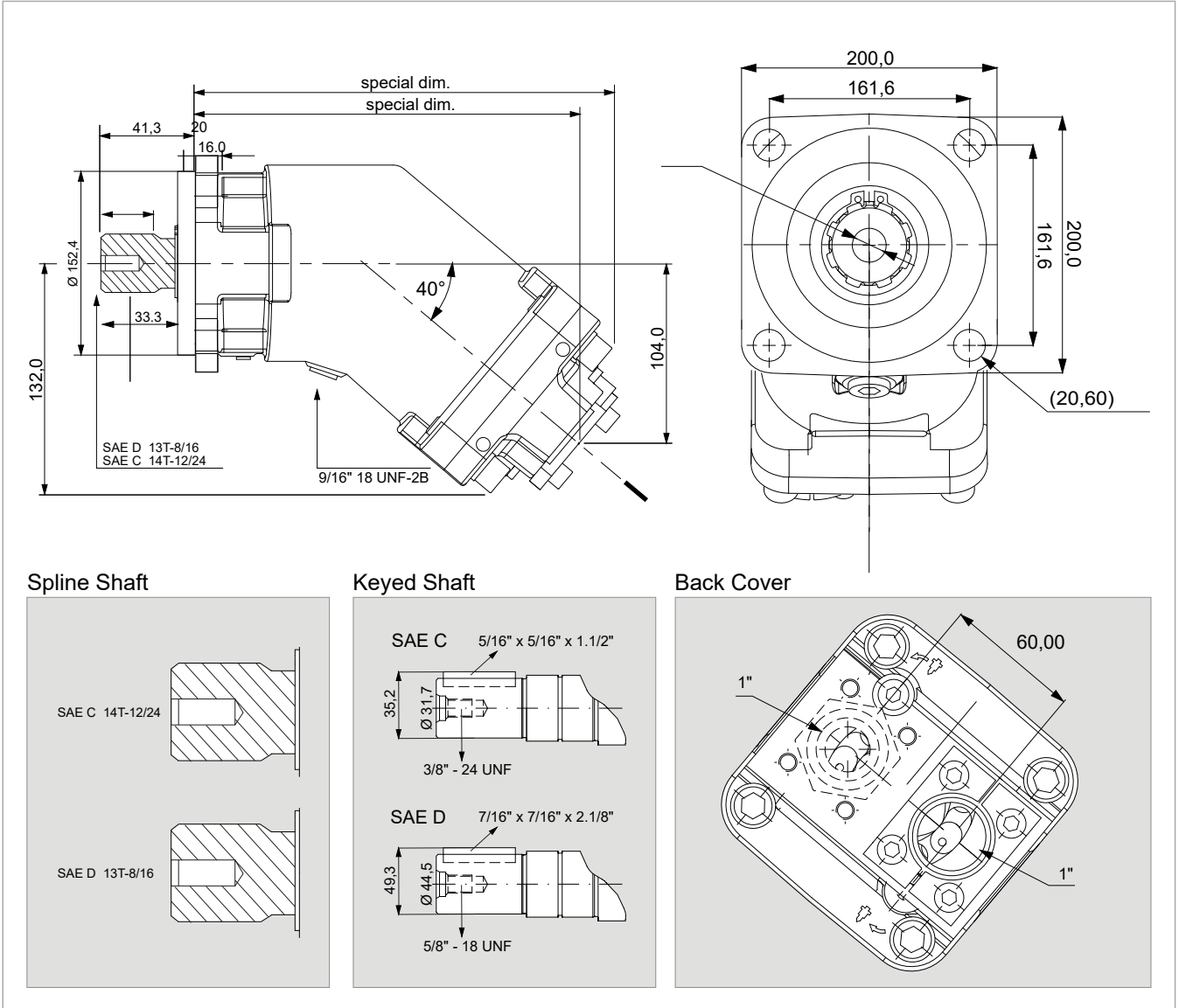

Spline Shaft

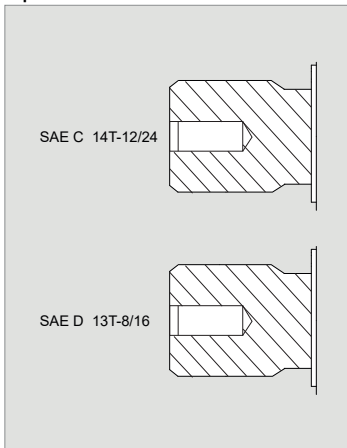

Keyed Shaft

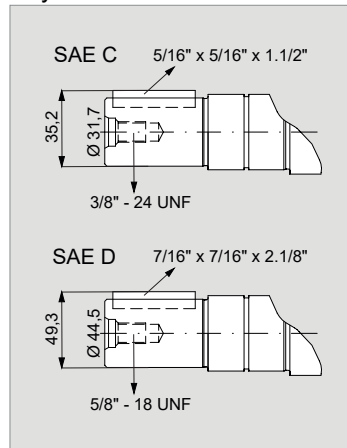

Back Cover

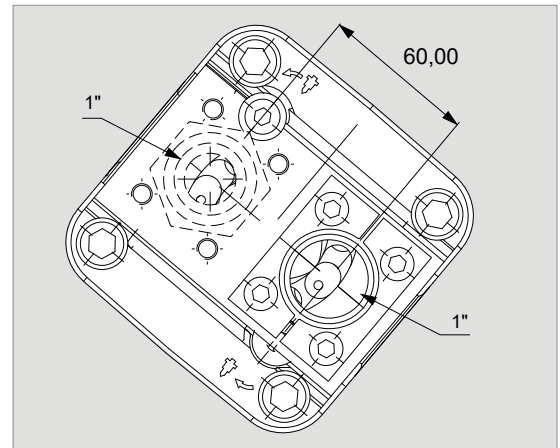

Flow, Speed, Pressure List of 2PE 108

<b>x 1000 rpm</b>	108,40 cc
<b>x 1500 rpm</b>	162,60 cc
<b>Max. Continuous Pump Speed</b>	1700 rpm
<b>Max. Limited Pump Speed</b>	1900 rpm
<b>Max. Continuous Pressure</b>	350 bar
<b>Max. Intermit. Peak Pressure</b>	400 bar
<b>Max. Torque at 350 bar</b>	620 Nm
<b>Weight without inlet fitting</b>	16,50 kg
<b>Weight with inlet fitting</b>	16,90 kg
<b>Rotation</b>	CW-CCW

