

2PE 50 - SAE C - 4 BOLT

SAE B 7/8" 13T-16/32DP
SAE BB 1" 15T-16/32DP

SAE C - 4 BOLT MOUNTING (SAE J744)

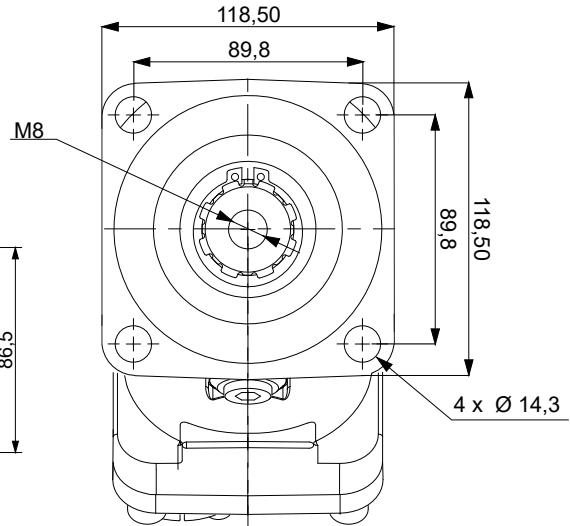
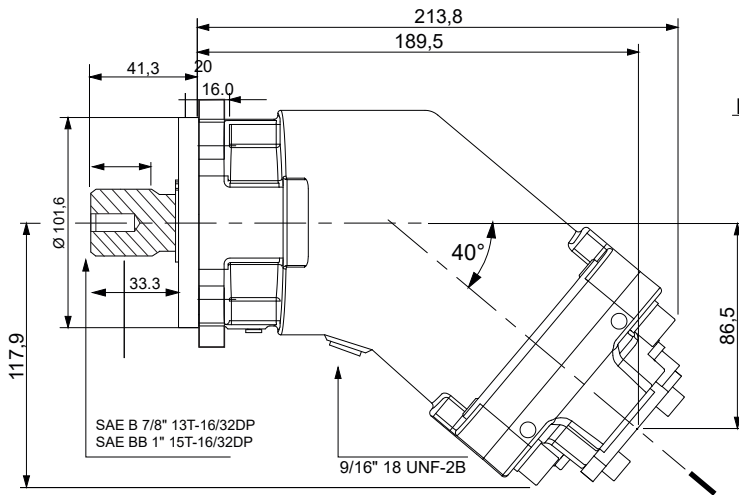

Spline Shaft

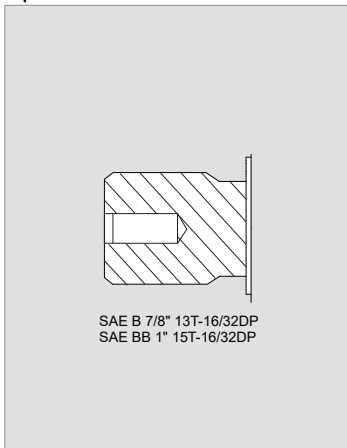

Keyed Shaft

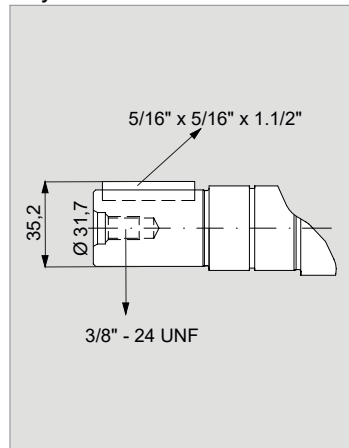

Back Cover

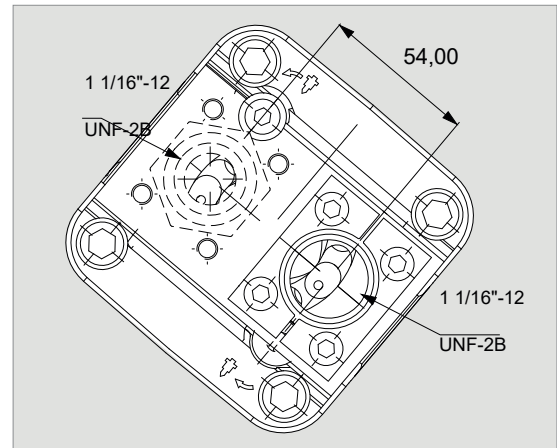

Flow, Speed, Pressure List of 2PE 50

x 1000 rpm	50,00 cc
x 1500 rpm	75,00 cc
Max. Continuous Pump Speed	1900 rpm
Max. Limited Pump Speed	2500 rpm
Max. Continuous Pressure	350 bar
Max. Intermit. Peak Pressure	400 bar
Max. Torque at 350 bar	292 Nm
Weight without inlet fitting	12,00 kg
Weight with inlet fitting	12,40 kg
Rotation	CW-CCW

