

Technical Information

iTEMP[®] TMT125

Temperature transmitter with
FOUNDATION Fieldbus™ protocol.

8 input channels for resistance thermometers,
thermocouples, resistance and voltage transmitters.



Application

- Temperature transmitter with 8 input channels and FOUNDATION Fieldbus™ protocol for converting various input signals into digital output signals
- Input:
 - Resistance thermometers (RTD)
 - Thermocouples (TC)
 - Resistance transmitters (Ω)
 - Voltage transmitters (mV)
- DIN rail mounting as per IEC 60715 and with aluminum housing for field operation

Your benefits

- Universal temperature transmitter for up to 8 input signals
- Inputs for RTD in 2-wire, 3-wire and 4-wire technology
- Every input can be configured individually
- Sensor monitoring: cable open circuit, short-circuit and wiring error
- Device hardware fault recognition for reliable operation and easy maintenance
- Galvanic isolation between fieldbus and sensor inputs and between the input channels
- Connection of thermocouples to all inputs possible
- Data transfer via FOUNDATION Fieldbus™ H1
- Transducer block 'concentrator' and Multiple Analog Input Block (MAI) allow for effective and fast configuration of the relevant parameters
- Approvals:
 - FM IS, NI
 - ATEX EEx ia, EEx na
 for intrinsically safe installation in zone 1 and as associated apparatus in zone 2
- Independent installation of connected temperature sensors in zone 0
- FISCO-compliant in accordance with IEC 60079-27 for easy measuring point layout in hazardous areas
- FOUNDATION Fieldbus™ ITK 4.61

Function and system design

Measuring principle

Electronic monitoring and conversion of various input signals in industrial temperature measurement.

Measuring system

Device architecture

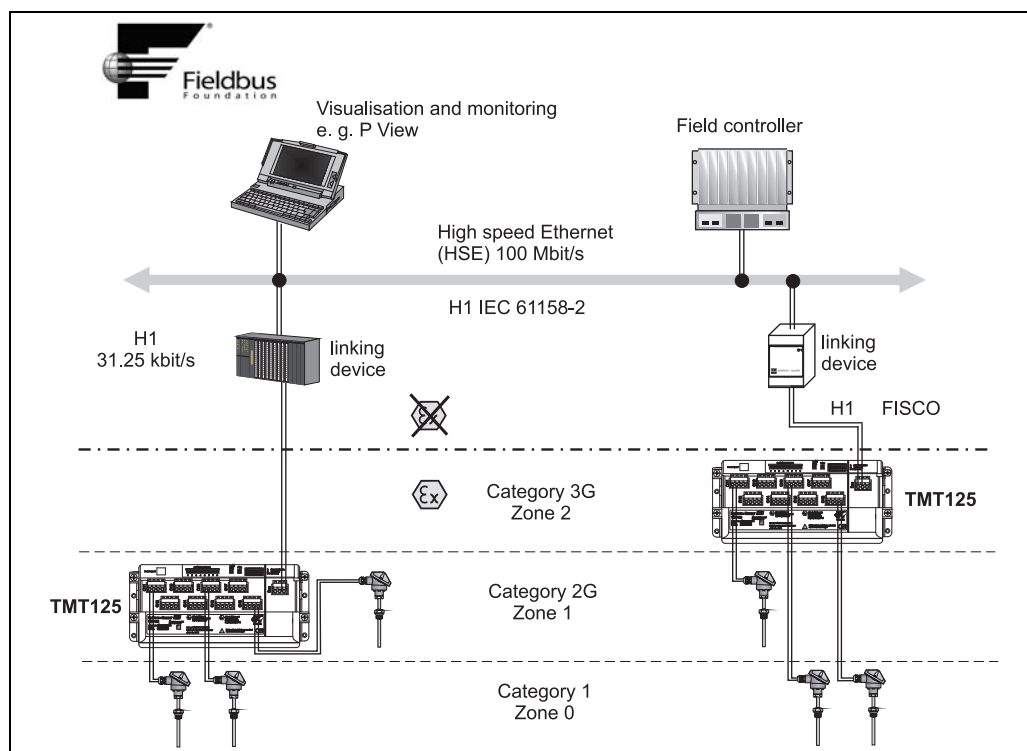

System integration via FOUNDATION Fieldbus™

30006754-en

The 8-channel temperature transmitter transfers both converted signals from resistance temperature measuring sensors and thermocouples as well as resistance and millivolt signals via FOUNDATION Fieldbus™. The device is powered via the FOUNDATION Fieldbus™ H1 bus and can be installed as intrinsically safe apparatus in zone 1 or as associated apparatus in zone 2 of hazardous areas. The device is available as a version for mounting on a DIN rail as per IEC 60715 and installed in a field housing for use in the field. The data is transferred via the following function blocks:

- 8 x Analog Input (AI) and
- 1 x Multiple Analog Input (MAI)

In addition, the Transducer block 'concentrator' allows for effective configuration of the parameters relevant for the temperature measurement. Every input can be individually configured and the individual inputs have a potential separation from each other of $U = 600 V_{ss}$.

Sensor diagnoses such as cable open circuit, short-circuit, wiring error and device hardware error are supported. LED displays provide information about the operating status and error status.

Input

Measured variable Temperature (temperature linear transmission behavior), resistance and voltage.

Measuring range The transmitter records different measuring ranges depending on the sensor connection and input signals.

Type of input Resistance thermometer (RTD)

Type	Standard	Measuring range limits	Maximum measured error (accuracy)	Temperature drift
Pt50	IEC 60751 (ITS90) ($\alpha = 0.00385$)	-200 to 850 °C (-328 to 1562 °F)	± 0.77 °C (± 1.39 °F)	± 0.0010 °C/K
Pt100		-200 to 850 °C (-328 to 1562 °F)	± 0.33 °C (± 0.59 °F)	± 0.0010 °C/K
Pt100	JIS C 1604-1989 ($\alpha = 0.003916$)	-200 to 630 °C (-328 to 1166 °F)	± 0.33 °C (± 0.59 °F)	± 0.0010 °C/K
Pt200	IEC 60751 (ITS90) ($\alpha = 0.00385$)	-200 to 850 °C (-328 to 1562 °F)	± 0.33 °C (± 0.59 °F)	± 0.0010 °C/K
Pt500		-200 to 850 °C (-328 to 1562 °F)	± 0.31 °C (± 0.56 °F)	± 0.0010 °C/K
Pt1000		-200 to 850 °C (-328 to 1562 °F)	± 0.31 °C (± 0.56 °F)	± 0.0010 °C/K
Ni100	DIN 43760-1987 ($\alpha = 0.006180$)	-60 to 250 °C (-76 to 482 °F)	± 0.18 °C (± 0.32 °F)	± 0.0010 °C/K
Ni120	Minco Standard	-80 to 320 °C (-112 to 608 °F)	± 0.18 °C (± 0.32 °F)	± 0.0010 °C/K
Ni200	DIN 43760-1987 ($\alpha = 0.006180$)	-60 to 250 °C (-76 to 482 °F)	± 0.18 °C (± 0.32 °F)	± 0.0010 °C/K
Cu10	SAMA RC21-4-1966 ($\alpha = 0.003923$)	-70 to 150 °C (-94 to 302 °F)	± 2.99 °C (± 5.38 °F)	± 0.0010 °C/K

- With 2-wire circuit, compensation of wire resistance possible (0 to 100 Ω)
- With 3-wire and 4-wire connection, sensor wire resistance to max. 50 Ω per wire

Thermocouples (TC)¹⁾

Type	Standard	Measuring range limits	Maximum measured error (accuracy)	Temperature drift	
				Range	Deviation
B	IEC 60584-1	300 to 600 °C (572 to 1112 °F) 600 to 1200 °C (1112 to 2192 °F) 1200 to 1800 °C (2192 to 3272 °F)	± 3.32 °C (± 5.98 °F) ± 1.77 °C (± 3.19 °F) ± 1.08 °C (± 1.94 °F)	300 to 600 °C (572 to 1112 °F) 600 to 1200 °C (1112 to 2192 °F) 1200 to 1800 °C (2192 to 3272 °F)	± 0.0060 °C/K ± 0.0131 °C/K ± 0.0242 °C/K
E		-200 to -50 °C (-328 to -58 °F) -50 to 1000 °C (-58 to 1832 °F)	± 0.42 °C (± 0.76 °F) ± 0.31 °C (± 0.56 °F)	-200 to -50 °C (-328 to -58 °F) -50 to 200 °C (-58 to 392 °F) 200 to 1000 °C (392 to 1832 °F)	± 0.0070 °C/K ± 0.0036 °C/K ± 0.0203 °C/K
J		-200 to 0 °C (-328 to 32 °F) 0 to 1000 °C (32 to 1832 °F)	± 0.48 °C (± 0.86 °F) ± 0.31 °C (± 0.56 °F)	-200 to 0 °C (-328 to 32 °F) 0 to 200 °C (32 to 392 °F) 200 to 1000 °C (392 to 1832 °F)	± 0.0072 °C/K ± 0.0039 °C/K ± 0.0243 °C/K
K		-200 to 0 °C (-328 to 32 °F) 0 to 1372 °C (32 to 2501 °F)	± 0.68 °C (± 1.22 °F) ± 0.43 °C (± 0.77 °F)	-200 to 0 °C (-328 to 32 °F) 0 to 500 °C (32 to 932 °F) 500 to 1372 °C (932 to 2501 °F)	± 0.0077 °C/K ± 0.0097 °C/K ± 0.0323 °C/K
N		-200 to -100 °C (-328 to -148 °F) -100 to 500 °C (-148 to 932 °F) 500 to 1300 °C (932 to 2372 °F)	± 1.03 °C (± 1.85 °F) ± 0.54 °C (± 0.97 °F) ± 0.39 °C (± 0.70 °F)	-200 to -100 °C (-328 to -148 °F) -100 to 500 °C (-148 to 932 °F) 500 to 1300 °C (932 to 2372 °F)	± 0.0080 °C/K ± 0.0088 °C/K ± 0.0264 °C/K
R		0 to 350 °C (32 to 662 °F) 350 to 1768 °C (662 °F to 3214 °F)	± 1.93 °C (± 3.47 °F) ± 1.16 °C (± 2.09 °F)	0 to 350 °C (32 to 662 °F) 350 to 800 °C (662 to 1472 °F) 800 to 1768 °C (1472 to 3214 °F)	± 0.0057 °C/K ± 0.0129 °C/K ± 0.0338 °C/K
S		0 to 550 °C (32 to 1022 °F) 550 to 1768 °C (1022 to 3214 °F)	± 1.92 °C (± 3.46 °F) ± 1.15 °C (± 2.07 °F)	0 to 550 °C (32 to 1022 °F) 550 to 800 °C (1022 to 1472 °F) 800 to 1768 °C (1472 to 3214 °F)	± 0.0094 °C/K ± 0.0135 °C/K ± 0.0355 °C/K
T		-200 to -50 °C (-328 to -58 °F) -50 to 400 °C (-58 to 752 °F)	± 0.66 °C (± 1.19 °F) ± 0.35 °C (± 0.63 °F)	-200 to -50 °C (-328 to -58 °F) -50 to 200 °C (-58 to 392 °F) 200 to 400 °C (392 to 752 °F)	± 0.0071 °C/K ± 0.0035 °C/K ± 0.0067 °C/K

Type	Standard	Measuring range limits	Maximum measured error (accuracy)	Temperature drift	
				Range	Deviation
W5Re W24Re	ASTM E988-96	0 to 800 °C (32 to 1472 °F) 800 to 2000 °C (1472 to 3632 °F)	± 0.80 °C (± 1.45 °F) ± 1.05 °C (± 1.89 °F)	0 to 800 °C (32 to 1472 °F) 800 to 2000 °C (1472 to 3632 °F)	± 0.0151 °C/K ± 0.0552 °C/K
<ul style="list-style-type: none"> ■ Cold junction internal ■ Accuracy of cold junction ± 0.5 °C (± 0.9 °F) 					

Resistance transmitter Ω

Measuring range limits	Maximum measured error (accuracy)	Temperature drift
0 to 650 Ω	± 115 m Ω	± 6 m Ω /K
0 to 1300 Ω	± 230 m Ω	± 6 m Ω /K
0 to 2600 Ω	± 460 m Ω	± 13 m Ω /K
0 to 5200 Ω	± 920 m Ω	± 26 m Ω /K

Voltage transmitter (mV)

Measuring range limits	Maximum measured error (accuracy)	Temperature drift
-100 to 150 mV	± 20 μ V	± 2 μ V/K

Output

Output signal	FOUNDATION Fieldbus™ H1, IEC 61158-2, galvanically isolated Physical Layer profile: <ul style="list-style-type: none"> ■ Profile type 511 (FISCO) ■ Profile type 111 (Entity) ITK version 4.61
----------------------	--

Linearization/transmission behavior	Temperature linear, resistance linear, voltage linear
--	---

Galvanic isolation	$\hat{U} = 375$ V AC (fieldbus/inputs)
---------------------------	--

Filter	50 or 60 Hz
---------------	-------------

Min. current consumption	≤ 23 mA
---------------------------------	---------

Switch-on delay	approx. 20 s
------------------------	--------------

Function blocks	<ul style="list-style-type: none"> ■ Resource block (RS): 1 x RS ■ Function blocks (execution time max. 40 ms, macro cycle ≤ 500 ms): 8 x Analog Input block (AI) 1 x Multiple Analog Input block (MAI) ■ Transducer blocks (TB): 8 x sensor TB 1 x concentrator TB
------------------------	--

FDE (Fault Disconnect Equipment)	6.7 mA
---	--------

1) Grounding of all thermocouples possible

Power supply

Electrical connection

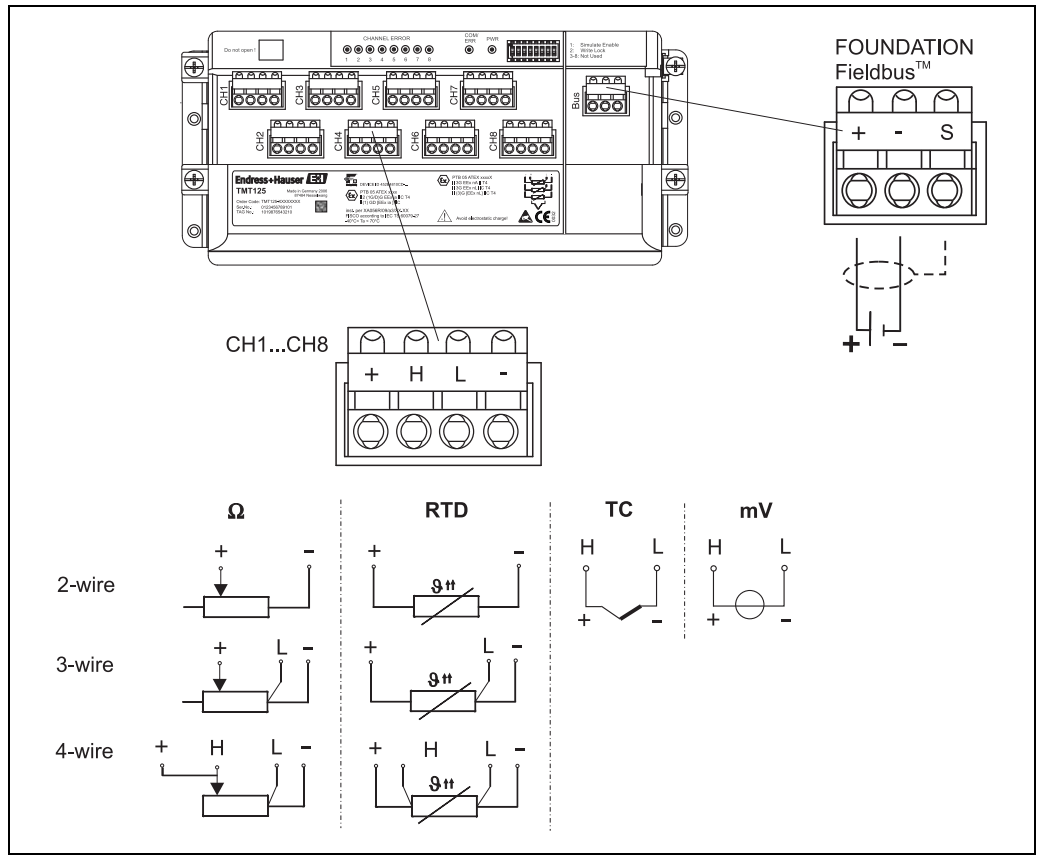

a0006330-en

Supply voltage

U = 9 to 32 V DC, reverse polarity protection

Cable entries (field housing)

Cable connections, material	Sensor connection		FOUNDATION Fieldbus™ connection	
	Cable gland	Cable diameter mm (in) / across flats	Cable gland	Cable diameter mm (in) / across flats
Terminals and cable guide, nicked brass	M16 x 1.5	5 to 10 (0.19 to 0.39") / 20	M20 x 1.5	7 to 12 (0.28 to 0.47") / 24

Performance characteristics

Response time	< 1 s per channel
Reference operating conditions	+25 °C ± 5 K (+77 °F ± 9 °F)
Maximum measured error	Accuracy for the various types of input, see → 3, under "Type of input".
Influence of ambient temperature (temperature drift)	Temperature drift for the various types of input, see → 3, under "Type of input".
Influence of cold junction	± 0.5 °C (± 0.9 °F)
Linearization	<ul style="list-style-type: none"> ■ RTD input 0.03 °C (0.054 °F) ■ TC input 0.1 °C (0.18 °F)
Internal update time	For all sensor types ≤ 1 s
Potential separation	600 V _{SS} (input/input)

Installation conditions

Installation instructions	Installation/mounting location Wall or cabinet mounting on DIN rail as per IEC 60715. A mounted device in aluminum field housing for field instrumentation is optionally available (for dimensions, see → 8).
----------------------------------	---

Environment conditions

Ambient temperature	Type of connection		Temperature range	
			Hazardous area	Non-hazardous area
	Field housing; cable guide, nicked brass	Without field housing	-40 to +70 °C (-40 to +158 °F)	-40 to +85 °C (-40 to +185 °F)
Storage temperature	-40 to +80 °C (-40 to +176 °F)			
Relative humidity	≤ 95 % not condensing, valid for the DIN rail version			
Climate class	Tested as per IEC 60068-2-30, meets the requirements regarding class C1-C3 in accordance with IEC 60721-4-3			
Degree of protection	Mounting on a DIN rail		IP 20	
	Mounting in aluminum field housing		IP 67	

Shock resistance

Impact resistance as per IEC 60068-2-27

Mounting on a DIN rail	15g, 11 ms
Mounting in aluminum field housing	15g, 11 ms

Vibration resistance

As per IEC 60068-2-6

Mounting on a DIN rail	5g, 10 to 150 Hz
Mounting in aluminum field housing	10g, 10 to 150 Hz

Electromagnetic compatibility (EMC)

This recommendation is a consistent and practical way of determining whether the devices used in laboratories and in process control systems are resistant to impact, thus increasing their functional safety.

ESD (electrostatic discharge)	IEC 61000-4-2	6 kV cont., 8 kV air	
Electromagnetic fields	IEC 61000-4-3	0.08 to 4 GHz	10 V/m
Burst (fast transients)	IEC 61000-4-4	1 kV	
Surge	IEC 61000-4-5	1 kV asym.	
Conducted RF	IEC 61000-4-6	0.01 to 80 MHz	10 V

Mechanical construction

Design, dimensions

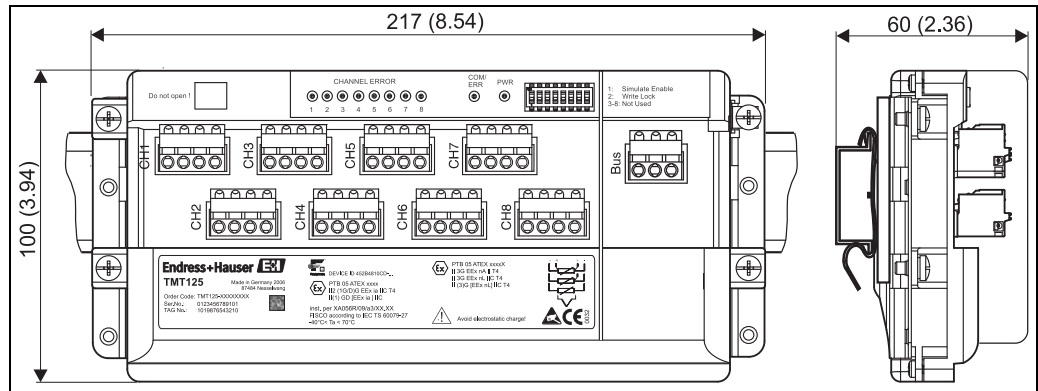

Housing for DIN rail as per IEC 60715; specifications in mm (in)

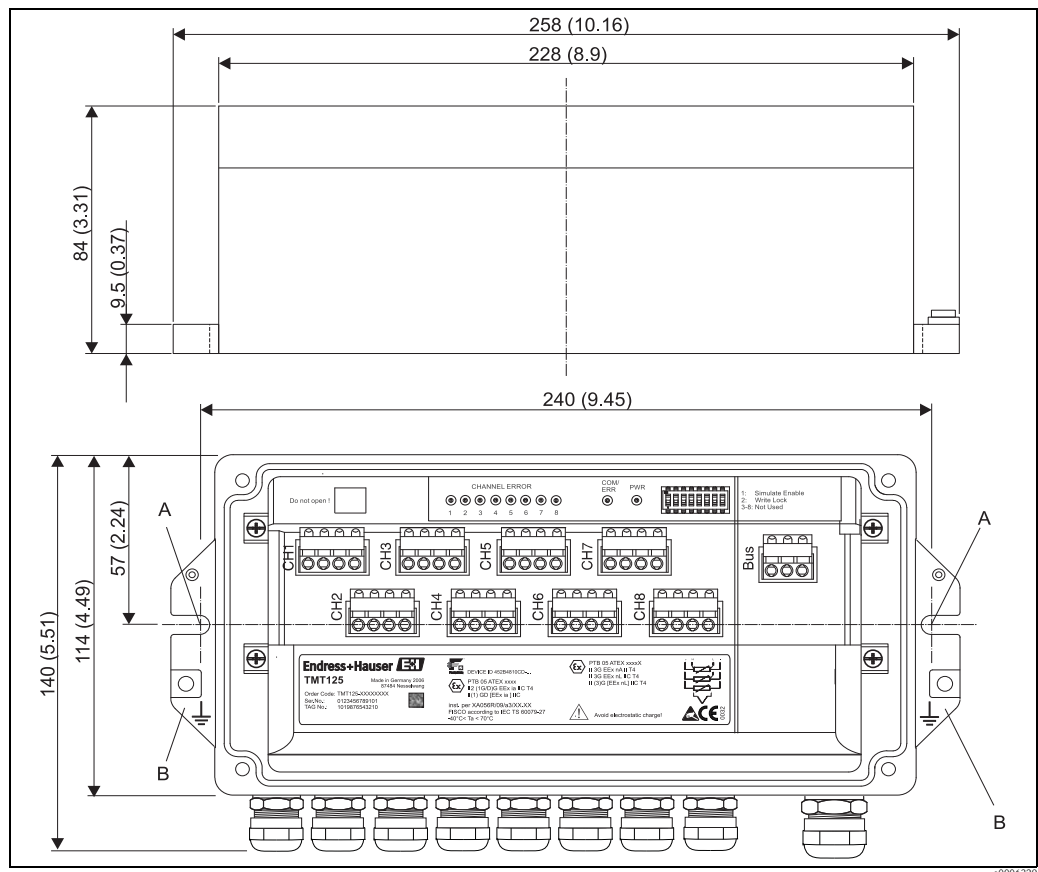

Dimensions of field housing; specifications in mm (in)

Item A: Securing with M6 bolt

Item B: Grounding, shielding point

Weight

- DIN rail version: 360 g (12.7 oz)
- Installed in field housing: 1.8 kg (3.97 lb)

Material

- DIN rail housing: polycarbonate (PC)
- Field housing: AlSi12 (Cu), EN573 (Si 1.2% - proportion), anodized
- Nameplate: polyester (PE)

Terminals

- Plug-in terminals, sensor and fieldbus cables up to max. 2.5 mm² (14 AWG)
- Specifications for cable glands and diameters → 5.

Human interface

Display elements

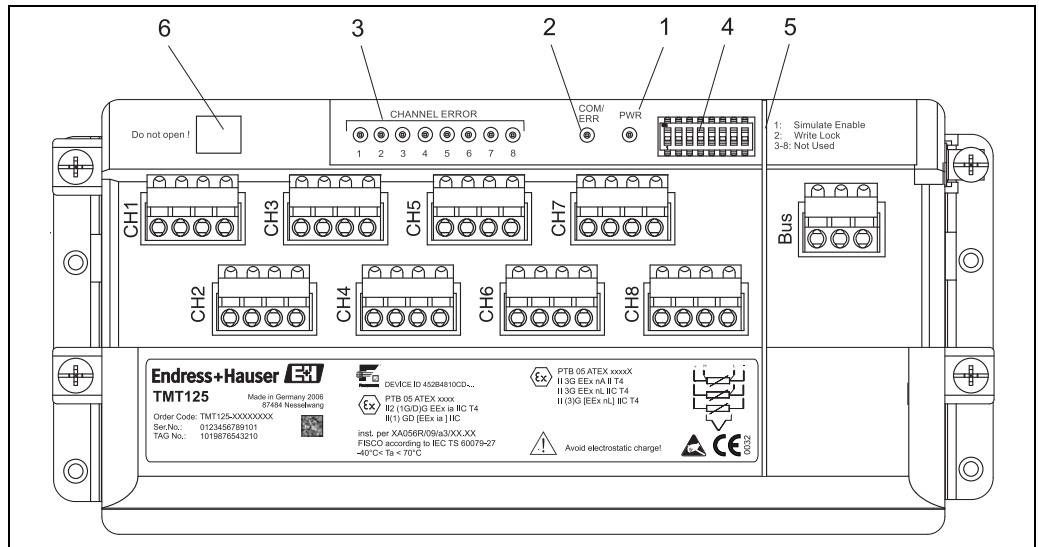

Operating and display elements of the temperature transmitter

Item 1: LED illuminated in green indicates 'In operation'

Item 2: LED illuminated in red or flashing red indicates 'Communication error: hardware or fieldbus error'

Item 3: LED flashing red indicates 'Channel error: cable open circuit or overshooting'

Item 4: DIP switch for hardware settings

Item 5: Segregation plate for mounting in hazardous area (device zone 2 - sensors zone 1 or zone 0)

Item 6: Service interface

Operating elements

- DIP switch for setting the parameters: hardware write protection and simulation (precondition for FOUNDATION Fieldbus™ simulation mode)
- Service interface, only relevant for service technicians!

Remote operation

The configuration of FOUNDATION Fieldbus™ functions and device-specific parameters is done via the fieldbus interface. You can obtain special configuration and operating programs from various manufacturers for these purposes.

Certificates and approvals

CE-Mark	The device meets the legal requirements of the EC directives. Endress+Hauser confirms that the device has been successfully tested by applying the CE mark.
Hazardous area approvals	For further details on the available Ex versions (ATEX, CSA, FM, etc.), please contact your nearest Endress+Hauser sales organisation. All relevant data for hazardous areas can be found in separate Ex documentation. If required, please request copies from us or your Endress+Hauser sales organisation.
Other standards and guidelines	<ul style="list-style-type: none">■ IEC 60529: Degree of protection provided by housing (IP-code)■ IEC 61158-2: Fieldbus for use in industrial control systems■ IEC 60068-2-27 and IEC 60068-2-6: Shock and vibration tests■ IEC 61326: Electromagnetic compatibility (EMC requirements)■ NAMUR Standards working group for measurement and control technology in the chemical industry (www.namur.de)
Certification FOUNDATION Fieldbus™	<p>The temperature transmitter has successfully passed all test procedures and is certified and registered by the Fieldbus Foundation. The device thus meets all the requirements of the specifications following:</p> <ul style="list-style-type: none">■ Certified according to FOUNDATION Fieldbus™ specification■ The device meets all the specifications of the FOUNDATION Fieldbus™ H1■ Interoperability Test Kit (ITK), revision status 4.61 (device certification no. available on request): the device can also be operated with certified devices of other manufacturers■ Physical layer conformance test of the FOUNDATION Fieldbus™

Ordering information

Product structure

This information provides an overview of the order options available. The information is not exhaustive, however, and may not be fully up to date. **More detailed** information is available from your local Endress+Hauser representative.

TMT125	iTEMP® TMT125, multi channel transmitter			
Approval				
A	Non-hazardous area			
B	ATEX	II 2(1G/D)G EEx ia IIC T4; II (1)GD EEx ia IIC		
C	FM IS	NI /I/1+2/ABCD/T4 FM AIS/I, II, III/1/ABCDEFG		
D	FMC IS	NL/I/1+2/ABCD/T4 FMC AIS/I, II, III/1/ABCDEFG		
E	IEC Ex	Ex ia IIC T4 [Ex ia] IIC		
F	IEC Ex	Ex nA II T4		
1	NEPSI	[Ex ia] IIC		
2	NEPSI	Ex nA II T4		
Communication				
1	FOUNDATION	Fieldbus		
Housing				
1	DIN rail, IEC 60715			
2	Field housing, alu, IP 67, 8x M16 + 1x M20 gland			
3	Field housing, alu, IP 67, 8x M16 gland + 1x plug 7/8" FF			
Connection				
1	Screw terminal			
Configuration				
A	Factory setup			
Version				
A	Standard			
TMT125-	1	1	A	A
← Order code				

Accessories

Order code	Type
71005804	Fieldbus connector (FOUNDATION Fieldbus™), for M20 → 7/8"
TMT125A-	AA Field housing 8xM16 + 1x M20 gland AB Field housing 8xM16 + 1x plug 7/8" FOUNDATION Fieldbus™

The following accessories are contained in the scope of delivery:

- Multi-language Brief Operating Instructions as hard copy
- Operating Instructions on CD-ROM

Documentation

- Operating Instructions iTEMP® TMT125 (BA240R/09/en) on CD-ROM and associated Brief Operating Instructions iTEMP® TMT125 (KA241R/09) as hard copy
- Ex supplementary documentation:
ATEX II 2(1G/D)G; II (1)GD; II 3G: XA056R/09/a3

Instruments International

Endress+Hauser
Instruments International AG
Kaegenstrasse 2
4153 Reinach
Switzerland

Tel.+41 61 715 81 00
Fax+41 61 715 25 00
www.endress.com
info@ii.endress.com

Endress + Hauser 
People for Process Automation