

***Hako***

*Clean ahead*

# Instruction Manual

Sweepmaster B980 R/RH /6502.40/6502.60)

## Introduction

Dear customer,

It is our desire that good characteristics of the Sweepmaster B980 R/RH should justify the confidence you demonstrated by making this purchase. We did our best to supply you with an efficient and dependable machine. Before first operation of you Sweepmaster B980 R/RH, read these instructions carefully. The manual provides valuable information about service and maintenance.

The symbol



as used in this manual identifies items relevant to safety. Please make sure to forward all safety instructions to other operators.

Observe the safety information listed in chapter 1.



Before first operation of the machine, read these instructions and safety information carefully and comply with them.

Please be advised explicitly that we cannot accept any legal issues out of the contents of this manual. It repair work has to be performed make sure that only genuine spare parts may guarantee a dependable machine and ill make sure that your rights under current warranty are not affected.

We reserve the right for technical improvement.

Valid as of : July 2014

**Hako GmbH**  
**D-23843 Bad Oldesloe**  
**Hamburger Str. 209-239**  
**Telefon +49 4531 806-0**

### Proper use

The Sweepmaster B980 R/RH sweeper has been exclusively designed for collecting dry and moist matter from floor surfaces in e.g. factories, storage buildings, parking ground and pedestrian areas. Using the machine beyond this scope of application will be deemed improper use; The manufacturer cannot be held liable for consequential damages.

The term of proper use also includes operation, maintenance and repair work to be performed in compliance with the manufacturer's specifications. The Sweepmaster B980 R/RH may be used by personnel only that are familiar with the machine and aware of possible hazards involved.

Accident Prevention Regulation, Road Traffic Regulations, and aspects of safety and working medicine will have to be complied with.

If modifications to the machine are made in absence of the manufacturer's prior consent, the latter cannot be

held liable for damage resulting from such unauthorized modification.



**The machine has not been designed for collecting dusts which are detrimental to health or explosive.**

### Notes on warranty

The terms of the sales contract apply. Damages are not subject to warranty if they are due to non-compliance with the maintenance and service provisions. The maintenance work has to be performed by an authorised Hako service centre and confirmed in the "Maintenance certificate" which is the warranty document.

The following is excluded from warranty:  
fuses, natural wear and tear after overload, and damages caused by inexperienced handling and unauthorised modification of the machine. Moreover,

any claim for warranty cannot be accepted if damages at the machine are caused by fitting parts or accessories without Hako's prior and explicit consent or by non-compliance with the maintenance instructions.

### Acceptance of the machine

Upon arrival, check machine for possible damages in transit. For refund of such damage, have the Deutsche Bahn AG or your freight forwarder confirm such damage. Mail notification and waybill to:

**Hako GmbH  
Hamburger Str. 209-239  
D-23843 Bad Oldesloe**

# Contents

<b>1</b>	<b>Safety Information</b>	<b>6</b>	<b>3</b>	<b>Battery Systems</b>	<b>19</b>	<b>7</b>	<b>Maintenance/Service</b>	<b>42</b>
1.1	General Safety Information	6	3.1	Low Discharge Signal Sender	20	7.1	Maintenance Instructions	42
1.2	Safety and Warning Symbols	7	3.1.1	Battery Charging Status Indicator	20	7.2	Mount/Dismount Cylinder Broom	43
1.2.1	Generally Applicable Symbols	7	3.1.2	Hourmeter	20	7.3	Adjust Sweeping Track	43
1.3	Labels at the Machine	8	3.1.3	Setting Other Battery Types	20	7.4	Sealing Strips for Broom Compartment	45
1.3.1	Sweepm. B980 R/RH Signs	9	3.2	Plug Connection Coding	21	7.5	Folding Apron Adjustment	45
1.4	Operation/Safety Information	11	<b>4</b>	<b>First Operation</b>	<b>23</b>	7.6	Replace Side Brush	46
1.5	Cleaning Information	12	4.1	First Operation of Batteries	23	7.7	Dismount Plate Filter	47
1.6	Maintenance Instructions	13	4.2	Insert Batteries	24	7.8	Basic Cleaning of Plate Filter	49
1.7	Accident Prevention Regulations	15	<b>5</b>	<b>Operation</b>	<b>26</b>	7.9	V-Belt Drive	
<b>2</b>	<b>Description</b>	<b>16</b>	5.1	Sweepm. B980 R/RH Controls	26		Sweepmaster B980 R/RH	50
2.1	Functional Description	16	5.2	Sweepmaster B980 R/RH Control Panel	28	7.9.1	Replace Cylinder Broom V-Belt	51
2.1.1	Sweepmaster B980 R	16	5.3	Empty Dirt Hoppers of Sweepmaster B980 R	33	7.9.2	Replace Side Brush V-Belt	51
2.1.2	Sweepmaster B980 RH	16	5.4	Empty Dirt Hopper of Sweepmaster B980 RH	33	7.9.3	Replace Suction Fan V-Belt	51
2.2	Cylinder Broom	17	5.5	Working With the Machine	36	7.10	Adjust Steering Chain Tension	52
2.3	Side Brush	17	5.5.1	Switch Electro-Motor ON and OFF	36	7.11	Check Hydraulic Fluid and Refill	52
2.4	Filter System / Dust Evacuation	17	5.5.2	Sweep	37	7.11.1	Check Hydraulic Fluid	52
2.5	Shaking System	17	5.5.3	Stop and Park	37	7.11.2	Refill Hydraulic Fluid	52
2.6	Steering	17	5.5.4	Displace	37	7.12	Electric System	53
2.7	Wheels	17	5.5.5	Transport	37	7.12.1	Fuses/Relays	53
2.7.1	Sweepmaster B980 R	17	<b>6</b>	<b>Technical Data</b>	<b>38</b>	7.12.2	Lifted-Up Disposal Fuses/Relays	54
2.7.2	Sweepmaster B980 RH	17				7.13	Sweepmaster B980 R/RH Maintenance Schedule	55
2.8	Brake	18						
2.9	Travel Drive Assembly	18						
2.10	Hydraulic System	18						

## Contents

<b>8</b>	<b>Special Equipment</b>	<b>57</b>
	<b>EC Decalartion of Conformity according to Directive 98/37/EG</b>	<b>59</b>
	<b>Maintenance Document</b>	<b>60</b>

# 1 Safety Information

## 1.1 General Safety Information

Apart from the instructions contained in this manual, the general safety instructions and accident prevention regulations, as imposed by law will have to be complied with. Do not put the Manual aside without reading it even if you used similar sweepers before. Take the time to read them now and save time later. It will be of essence to make yourself familiar with all accessories and controls, as well as their functions, before you start working. Take time to read now and save time later.

Machines with known defects must not be used.

Prior to operation make yourself familiar with all systems and controls and "where they arrive". Avoid the mess of having to read this book while trying to run the machine.

Using the machine in areas with explosion hazard, on public roads and places is prohibited.

The operator has to use the machine within its design limits. Shut the motors down before transporting the machine.



### Keep clear of hazard zone!

Before commencing work, the operator has to make sure that the Sweep-master B980 R/RH and its accessories are in proper and safe condition. Warning and instruction labels attached to the machine contain important information about safe operation. Illegible or lost labels have to be replaced.



### Make sure that all covers are fitted before starting to sweep.



**When sweeping in closed rooms, provide for sufficient ventilation.**





**Pinching and shearing hazard. Provide for required safe distance before lifting or lowering the dirt hopper.**

## Sicherheitsinformationen

### 1.2 Safety and Warning Symbols

#### 1.2.1 Generally Applicable Symbols

All paragraphs in this manual referring to your personal safety, the safety of your machine and the environment protection are attributed one of the following warning symbols:

Symbol	Hazardous for....	Description
<b>DANGER</b> 	persons and goods	<b>dangerous situation</b> caused by imprecise or non-observance of instructions or prescribed work routine
<b>CAUTION</b> 	the machine	important information on handling the machine in order to maintain operability
<b>Ecological hazard</b> 	the environment	due to use of substances representing an inherent danger to health of environment

## Safety Information

### 1.3 Labels at the Machine

The following safety and information signs are legibly attached to the machine. Missing or illegible stickers have to be replaced.

Folding apron (1)

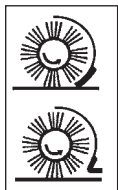

Parking brake (2)



Hako nameplate, front and rear (3)

# Hako

Read and observe operator's Manual (4)



Key switch (5)

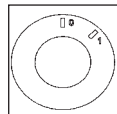

Brake (6)

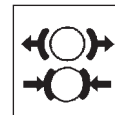

Noise performance (7)

**82 dB (A) B980 R**

**82 dB (A) B980 RH**

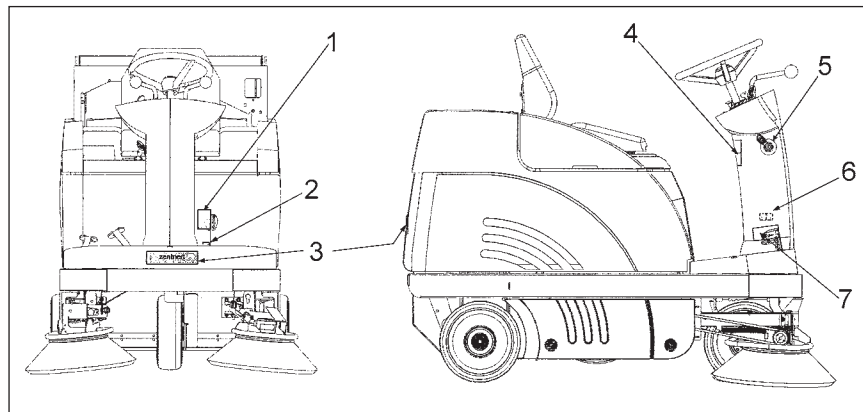
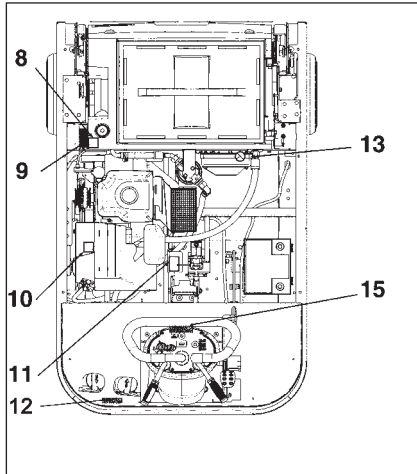

Fig.1



## Safety Information

### 1.3.1 Sweepmaster B980 R/RH Signs

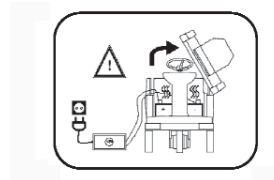

**Fig.2**  
**Safety and information signs**

#### 24V label (8)



Battery charging (9)  
The label is located under the seat hood.



#### Rotating parts (10)



#### Cylinder broom wearing take-up (11)

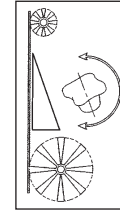

#### Nameplate (12)

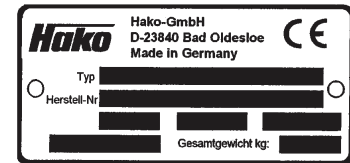

## Safety Information

Sweepmaster B980 R/RH Signs  
Continued

High-pressure cleaner (13)



**Do not clean by means of high pressure cleaner or vapour jet.**

Sweepmaster type name (14)

**Sweepmaster B980 R**

**Sweepmaster B980 RH**

Brake (15)



Pinching hazard (16)



Hydraulic fluid (17)



## Safety Information

### 1.4 Operation/Safety Information

Vacuum sweepers may be run by qualified personnel only; such personnel will have to have evidenced their qualification for running the machine to the owner or his authorised representative; operators explicitly will have to be instructed by the owner or his authorized representative to use the machine.



**The machine may be used for cleaning such surfaces approved by the owner or this authorised representative for operation of vacuum sweepers.**



**Before starting the engine, switch off all drives**

Transporting persons on the machine is prohibited. Ride-on machine types are to be started with the driver being seated.

Never leave the machine unattended before the motors are off and the machine is protected against unintended movements.

To prevent the machine from unauthorised use, pull the control key to block all drives.

Shut down the motors before transport of the machine. During driving the operator has to take account of local conditions and when working he has to watch out for other persons, especially children.



**Do not open the hood with the machine running.**



**This machine must not be used as dust-evacuating machine with dust filter insert (separator) to collect dusts which are hazardous to health.**



**Compared to four-wheeled vehicles, driving stability of three-wheeled vehicles is reduced. We thus recommend:**

- do not negotiate curves at high speed.
- do not turn at slopes but on level ground only
- ride up- or downhill straight.

## Safety Information



**Warning and instruction labels attached to the machine contain important information about safe operation**



**Provide for sufficient ventilation when sweeping indoors.**



**Proceed to filter shaking only after having closed the dirt hopper.**



**Do not open the hood with the machine running.**



**Proceed to filter shaking only if the dirt hopper is in closed position.**

### 1.5 Cleaning Information

The specific safety instructions for handling drive batteries (see leaflet 88-60-2556) apply. Before proceeding to cleaning of the machine, pull the key.

The machine is splash-proof (IPX3).



**Do not clean the Sweepmaster B980 R and RH by means of high pressure cleaner or vapour jet.**



**Proceed to cleaning of the dirt hopper in regular intervals to preclude formation of bacterial deposits.**

## Safety Information

### 1.6 Maintenance Instructions

A good approach to prevention of accidents is proper maintenance of the machine. Before proceeding to repair or maintenance work pull the key. Use appropriate tools for maintenance, service, setting etc. As far as aspects of safety are concerned, spare parts will have to be at least of the same quality as the genuine spare parts.



**Switch off the motors before maintaining the machine or replacing parts of it. Turn off the machine, pull the key and, additionally, disconnect the battery plug.**



**Check hydraulic lines and hoses for damages and leakage in regular intervals; replace defective hoses and lines immediately!**



**Before changing wheels protect the machine against rolling by placing wedges. Proceed to wheel changing when the machine is on level and solid ground.**



**Do not repair the pneumatic tires mounted to the machine yourself. Dismount the wheel and take it to repair to qualified workshop.**



**Use of other than the cylinder brooms and side brushes approved by the manufacturer is not admitted (see technical data) since use of other cylinder brooms and side brushes may affect your safety.**

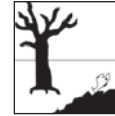

**When handling lubricating agents, the applicable regulations for protection of the environment and prevention of fire have to be complied with. Provide for disposal of used oil and grease in accordance with the provisions imposed by law.**

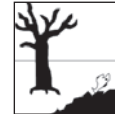

**Collect cleaning agents, oil, fuel oil, grease etc. and provide for adequate disposal. Wipe away spilled substances.**

Specific safety instructions for handling batteries apply (**refer to leaflet 88-60-2556 for further safety provisions**)

## Safety Information

Specific safety instructions for handling batteries apply

(refer to leaflet 88-60-2556 "Information on Drive Batteries" for further safety provisions).



Before commencing any work on the electric system disconnect battery plug of the Sweepmaster B980 R and RH.



Do not keep batteries discharged for a longer period; always recharge them as soon as possible.



Top with distilled water only. Never refill battery acid in battery cells of perfect condition.



Open the hood before charging batteries; explosive gases may occur during the charging procedure.



Keep batteries dry and clean and clear of soiling such as e.g. metallic dust to avoid leakage current.



Do not place metal objects or tools onto batteries. Short-circuit and deflagration hazard.



Spilled (straight) battery acid must not get into the sewage system before having been neutralised. Comply with the regulations imposed by law and observe local provisions.



Battery acid is highly caustic (keep clear of children). When checking the battery acid level, wear safety glasses. If acid splashes get into the eyes rinse with clear water for 15 minutes and contact a doctor immediately. Wear appropriate protective clothes (e.g. protective gloves or

finger-stalls) when handling battery acid.



Do not use open flames (explosion hazard).



Do not eat, smoke or drink in rooms where batteries are charged to avoid damaging your health. After work with batteries wash your hands thoroughly. Provide for sufficient ventilation.

### 1.7 Accident Prevention Regulations

BGV D 29

#### **Vehicles**

According to BGV D 29, the Sweepmaster B980 R/RH vacuum sweeper has to be inspected for safe condition by an authorized expert as required, but not less than once a year. Results of such an inspection have to be kept on file at least until the next inspection is performed.

BGV D 27

Observe as well:

#### **Industrial trucks**

- the applicable provisions for Safety and Health at Work and the Fire Regulations
- internal safety provisions

## Description

## 2 Description

### 2.1 Functional Description

#### 2.1.1 Sweepmaster B980 R

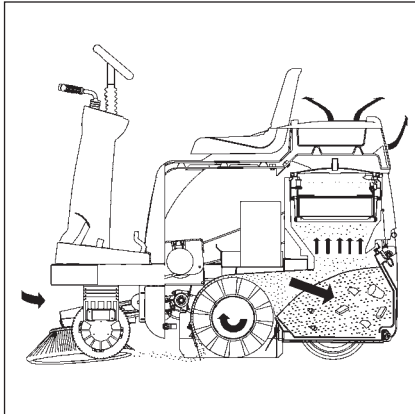

Fig.3

Principle of  
Sweepmaster B980 R

The side brushes are used to collect dirt at borders and to enlarge the working width as well as to increase the area performance on large surfaces. The cylinder broom transports the debris into the dirt hopper. The suction fan vacuums the fine dirt which is separated by a filter system. The air returned into the environment is clean.

#### 2.1.2 Sweepmaster B980 RH

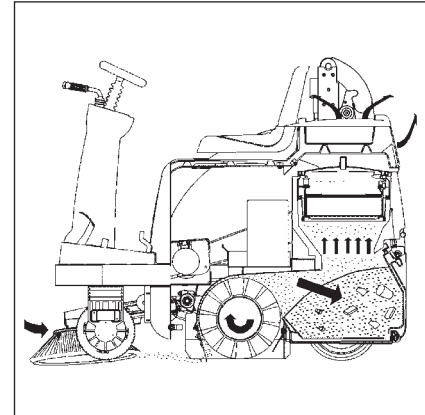

Fig.4

Principle of  
Sweepmaster B980 RH



## Description

### 2.2 Cylinder Broom

The cylinder broom is equipped with 12 rows of bristles arranged in V-shape.

The cylinder broom width amounts to 700mm and its diameter to 345mm.

### 2.3 Side Brush

The standard version, the side brush is located at the front right of the machine. The operator lifts and lowers it by hand lever.

The side brush is to have a light inclination.

The swinging area of the side brush arm is limited by stop screws.

The side brush is driven by V-belt.

For special application, fitting of a second side brush at the left is possible.

### 2.4 Filter System / Dust Evacuation

The filter system is located in the filter case above the dirt hopper. The suction fan transports the fine dust raised by the cylinder broom to the plate filter where it is separated. The fine dusts sets at the outsides of the filter blades.



**In case of heavy dust development, check and clean the plate filter at regular intervals.**

### 2.5 Shaking System

Due to normal working vibration the set dust partly falls off into the dirt hopper. To ensure working in a dust-free ambiance, however, actuate the shaking system regularly.

### 2.6 Steering

Steerage is effectuated mechanically from steering wheel to front wheel via chain. This chain is to be re-adjusted as required.

### 2.7 Wheels

2.7.1 ISweepmaster B980 R  
Front wheel: solid rubber tires

Rear wheels: solid rubber tires

2.7.2 Sweepmaster B980 RH  
Front wheel: solid rubber tires

Rear wheels: solid rubber tires

## Description

### 2.8 Brake

The Sweepmaster B980 R/RH is equipped with a service brake. This brake has been constructed as shoe brake and equally serves as parking brake. It is located in the rear wheels and is actuated via cables. A special adjustment screw is situated at the right-hand rear wheel.



**Works at the braking system have to be executed by qualified persons in a qualified workshop only.**

### 2.9 Travel Drive Assembly

The Sweepmaster B980 R and RH is equipped with an electric drive assembly with continuous regulation.

### 2.10 Hydraulic System

The hydraulic system includes a compact unit (hydraulic pump with hydraulic tank) as well as hydraulic hoses and a hydraulic cylinder.

Hydraulic fluid: Mobiloil DTE 15 M

The hydraulic system has been filled with fluid in the factory.

Filling of hydraulic fluid tank: 0.76 litre

### 3 Battery Systems

Sweepmaster B980 R/RH	Qty.	Order.-No.
Battery system A:		
6V/240Ah GiV block battery, maintenance-free	4	7401
Cable set for battery connection		6503
24V/35A charger unit, variable IUlola and IUloU characteristic, 230V AC		4003
Battery system B:		
24V/210Ah tray battery, EPzB, with Aquamatik		4201
24V/35A charger unit, variable IUlola and IUloU characteristic, 230V AC		4003



Before commencing any work on the electric system disconnect the battery plug. Do not use open flames when handling batteries and especially when checking the battery acid level. Provide for sufficient ventilation in rooms where batteries are charged. Spilled (straight) battery acid must not get into the sewage system before having been neutralised.



Comply with the regulations imposed by law and observe local provisions.



Open the hood before charging batteries; explosive gases may occur during the charging procedure.

## Battery Systems

### 3.1 Low Discharge Signal Sender

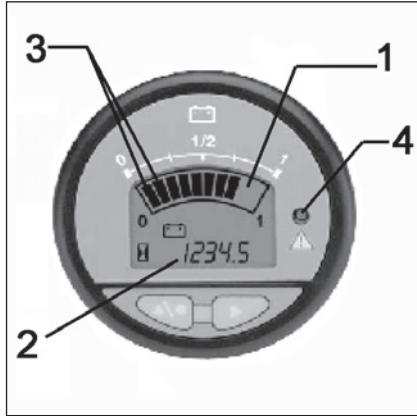

Fig.5

Battery charging status indicator/hourmeter



The factory setting is as follows:  
**maintenance-free block battery, 4x6V block batteries, type: GiV**

### 3.1.1 Battery Charging Status Indicator

Upon turning ON by key switch, battery charging status is shown by display of green bars (Fig. 5/1). As the battery discharges during operation, the lighting green bars extinguish one after another showing thus always the current charge status of battery charge.

Flashing of the last two green bars indicates that operation will be stopped soon. In order to preclude low discharge of batteries, the sweeping units are switched off and riding speed reduced to 50% if battery is discharged. The red LED (Fig. 5/4) then flashes.

### 3.1.2 Hourmeter

The operating hours of the machine appear in the display (Fig. 5/2); the hourmeter will count only during working or transport ride; only full hours are displayed).

### 3.1.3 Setting Other Battery Types



**Have the low discharge signal sender set to other battery types by qualified personnel only and in approved qualified workshops only.**

## Battery Systems

### 3.2 Plug Connection Coding

The battery plugs of the machine, the battery and the stationary charger unit have to be coded according to the battery type and the nominal voltage with coloured pins.

The charger unit's plugs are/will be coded in the factory according to the characteristic curve and changing the characteristic curve (according to the battery type) always requires modification of the plug coding.

Plug case of charger unit:

- grey for wet batteries
- green for maintenance-free

Gel batteries

Machine plug case:

- yellow for both battery types

Battery socket case:

- grey for wet batteries
- green for maintenance-free

Gel batteries

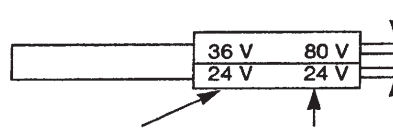

Nominal voltage value for plug printed on each side of the hexagon (letters upside down)

Inscription for nominal voltage for sockets accordingly

Remove the coding pin by pressing the ends together by means of pliers.

Press together for assembly

Insert pin such that the nominal voltage inscription is visible through the case window. Socket and plug always with the same nominal voltage!

The following three requirements have to be met:

- 1) Voltage coding is the same for all plugs and sockets
- 2) Coding pin colour in the machine = yellow
- 3) Coding pin colour



**Before first operation of the machine, the batteries have to be adequately charged by an initial charging procedure. Please observe the instructions of the charger unit's operating manual. Hako rejects any claim for warranty on battery damages caused by unfulfilled initial charging.**

## Battery Systems

### Coding system in plug connectors for wet and dry batteries (example for 24 V)

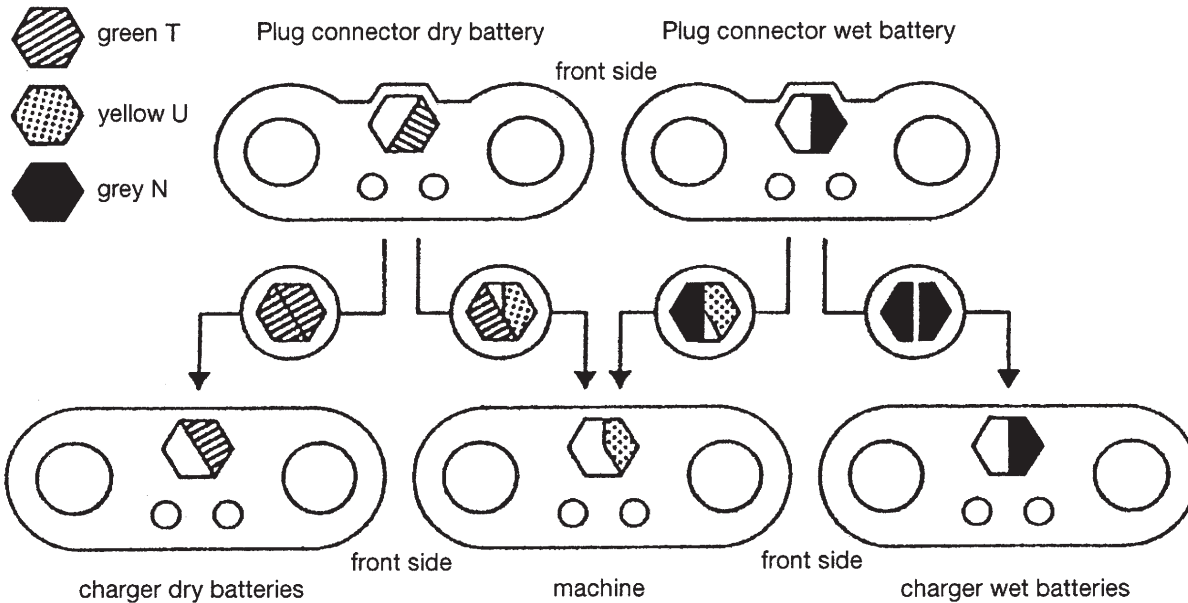

### 4 First Operation

Before delivery, the Sweepmaster B980 R/RH has been extensively tested and submitted to a functional check. Only qualified personnel of your local Hako contact dealer are allowed to proceed to first operation. After shipping of the machine, we advise your Hako contact dealer. He will contact you to make a date for briefing lessons.

#### 4.1 First Operation of Batteries

To achieve the optimum performance and a maximum service life, the batteries must be given the initial charge after filling.

Handling and function of the battery charger is described in detail in the instruction manual supplied with each charger unit.



**Since batteries and charger units are matched, we recommend using batteries and chargers as prescribed by Hako. We can grant full warranty only if those units are being used.**

For further information on first operation, maintenance and service of batteries refer to the leaflet **88-60-2556 "Information on drive batteries"**.



**Do not use the Sweepmaster B980 R/RH at ambient temperatures of more than 40°C. Do not start the machine at temperatures of 0°C or less.**

## First Operation

### 4.2 Insert Batteries

- Turn engine off and pull key
- Secure machine by engaging the parking brake.
- Fold back seat hood.
- Insert batteries into the battery tray from the top.

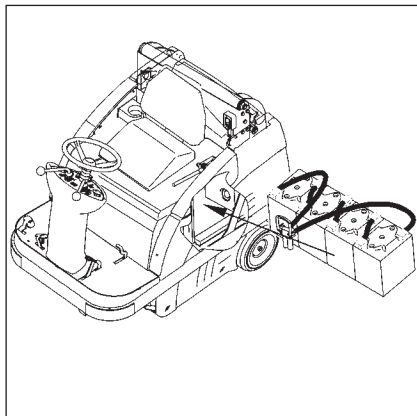

Insert batteries

Fig.6

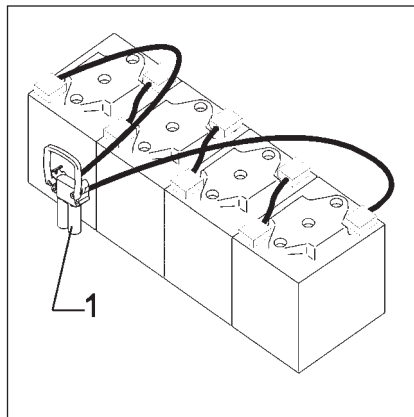

Fig.7

#### 6V/240Ah, GiV maintenance-free

- Connect batteries and enclosed cable set according to Fig. 7 (check for tight seating) and grease poles.
- Check set battery type at the low discharge signal sender or set if required.
- Connect charging plug of the battery connection cable and cable of the charger unit and proceed to initial charging.

- After charging of the batteries, connect charger plug and device plug for electrical connection.

Now the Sweepmaster B980 R/RH is operable.



**If the battery type setting at the LDS should be incorrect, have the setting modified by qualified personnel in an approved workshop.**



## First Operation

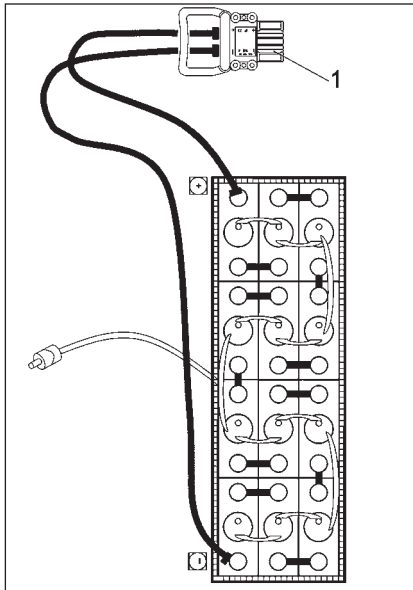

Fig.8

24V/210Ah tray battery, EPzB  
with Aquamatik

- Turn machine off and pull key.
- Secure machine by actuating parking brake.
- Fold up seat hood
- Insert battery
- Connect charging plug of the battery connection cable and cable of the charger unit and proceed to initial charging.
- After charging of the batteries, connect charger plug and device plug for electrical connection.



**If the battery type setting at the LDS should be incorrect, have the setting modified by qualified personnel in an approved workshop.**



**Use admitted lifting and transport devices such as e.g. lifting tackles according to VDI 3616. Make sure that lifting hooks do not damage cells, connectors or connecting cables.**

## 5 Operation

### 5.1 Sweepmaster B980 R/RH Controls

- 1 Actuator for folding apron
- 2 Service brake lock
- 3 Service brake/parking brake pedal
- 4 Drive pedal, reverse
- 5 Drive pedal, forward
- 6 Control panel
- 7 Seat adjustment

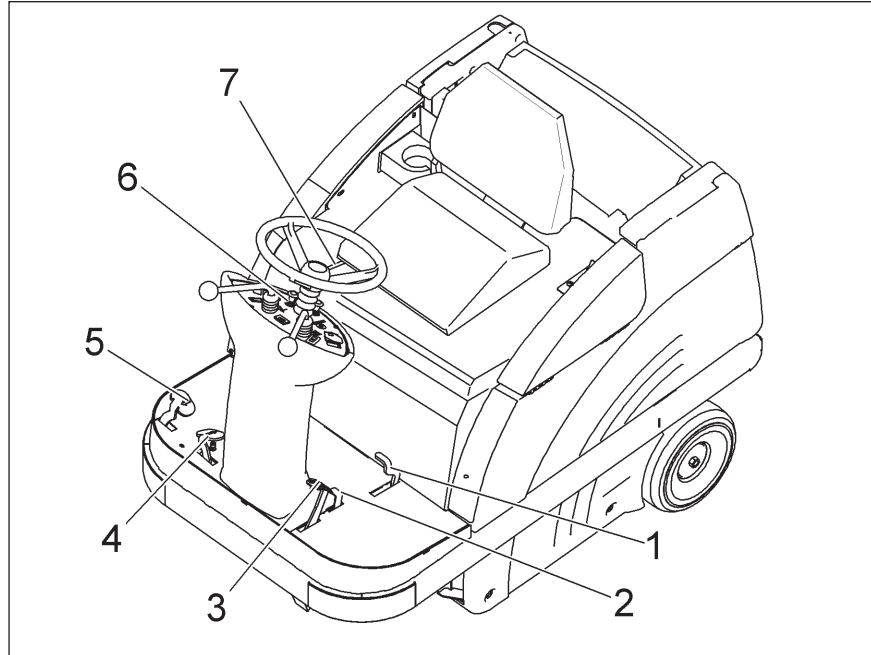

Fig.9

## Operation

### 1 Actuator for folding apron

to open and close the folding apron for collecting coarse dirt.

### 2 Service brake/parking brake lock

to lock the service brake/parking brake. If locked, the service brake works as parking brake. Release the lock by depressing the service brake pedal (3).

### 3 Service brake/parking brake pedal

to actuate the service brake at the rear wheels. Before leaving the machine unattended, engage the service brake and lock.

### 4 Drive pedal, reverse

to change direction to reverse ride and with continuous regulation of riding speed at the same time. If the driver lets the pedal go it returns to initial position and the machine slows down to standstill.

### 5 Drive pedal, forward

to change direction to forward ride and with continuous regulation of riding speed at the same time. If the driver lets the pedal go it returns to initial position and the machine slows down to standstill.

### 6 Control panel

Refer to chapter "Control panel"

### 7 Seat adjustment

to adjust the seat position to drivers of different height. Adjust the seat so as to allow the driver being comfortably seated and attaining all elements required for operation.

- Adjust seat lengthwise: push lever slightly to the right and displace seat forwards or backwards to the required position. Then let the lever catch again.

## Operation

### 5.2 Sweepmaster B980 R/RH Control Panel

- 1 Cylinder broom lever
- 2 Release (lifted-up disposal)
- 3 Horn
- 4 Cover with plug connection for battery/LDS programming
- 5 Suction fan/shaking system knob
- 6 Flashlight (optional/6505)
- 7 Lighting (optional/6506)
- 8 Lift and lower (lifted-up disposal)
- 9 Side brush lever
- 10 Pilot lamp, parking brake
- 11 Battery charge status indicator/hourmeter
- 12 Pilot lamp, fan
- 13 Pilot lamp, shaking system
- 14 Key switch

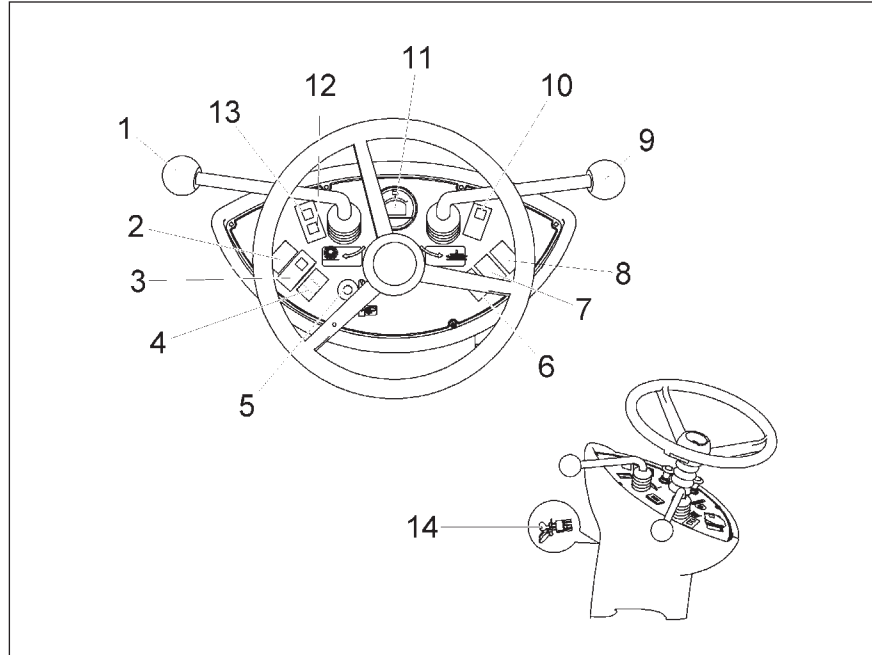

Fig.10

## Operation



### 1 Cylinder broom lever

to lift and lower as well as to switch on and off the cylinder broom and the side brush.

- Lower cylinder broom as well as switch on cylinder broom and side brush = push lever
- Lift cylinder broom as well as switch off cylinder broom and side brush = pull lever



### 2 Release (lifted-up disposal)

to release the lifted-up disposal.



**Has to be actuated before activation of lifting/lowering lifted-up disposal function. Hold the key during lifting/lowering.**



**Before changing lifting to lowering or vice versa, the "Release Lifted-Up Disposal" key has to be released once and pressed again**



### 3 Horn

An acoustic signals sound upon actuation of this button.

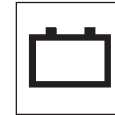

### 4 Cover with plug connection for battery/LDS programming

Remove this cover to modify setting of battery type. The plugged connections of the programming cable are located there.



**Have the programming executed by a Hako contract dealer with qualified personnel at hand.**

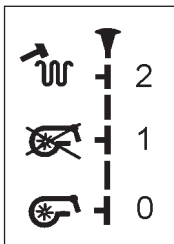

## 5 Suction fan/shaking system knob

Knob position (from bottom to top position):

Pos. 0 Activated vacuuming function (close flap before sweeping dry surfaces or collecting dry dirt).

Pos. 1 Deactivated vacuuming function (open flap before sweeping wet surfaces and collecting wet dirt).

Pos. 2 Shaking system ON (pull knob to stop and then release)

If the yellow pilot lamp (Fig. 9/13) lights, actuate the shaking system (position 2). In this position, the shaking system is operable and proceeds to jolting in 7 repeated intervals.



**After jolting, the knob is to be kept in position 1 for about 10 seconds. Switch off the main broom before and do not turn on during jolting.**



## 6 Flashlight (optional/6505) to switch the flashlight ON/OFF.



## 7 Lighting (optional/6506)

to switch the driving headlight ON/OFF.

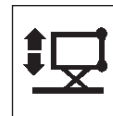

## 8 Lift and lower (lifted-up disposal)

to lift and lower the dirt hopper. Lift the dirt hopper by pressing the key until the desired height for lifting-out is attained. When lowering the dirt hopper make sure to hold the key pressed until the hopper has contact with the frame.

## Operation



**Actuate release key for lifted-up disposal and hold before lifting or lowering.**



### 9 Side brush lever

- to lift and lower the side brush.
- Lower side brush = push lever
  - Lift side brush = pull lever



### 10 Pilot lamp, parking brake (red)

lights upon actuation of the parking brake  
Extinguishes upon release of the parking brake.

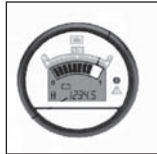

### 11 Battery charge status indicator

Refer to paragraph 3.1.1

### Hourmeter

Refer to paragraph 3.1.2

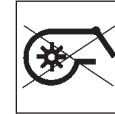

### 12 Pilot lamp, suction fan (orange)

lights if the suction fan is not activated.



### 13 Pilot lamp, shaking system (yellow)

Proceed to jolting of the filter system upon lighting of this pilot lamp by actuating the knob (Fig. 10/5).

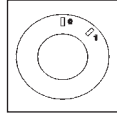

### 14 Key switch

to switch the machine on and off and to secure it against unauthorised use.



**The pilot lamp flashes during the shaking procedure and extinguishes after low pressure has been attained in the filter system. Jolting is effectuated in 7 intervals.**



## Operation

### 5.3 Empty Dirt Hoppers of Sweepmaster B980 R

- Fold bow (Fig. 11/3) up = the dirt hoppers (Fig. 11/2) are lowered.
- Use the recessed grip (Fig. 11/1) of one of the hoppers to lift it lightly and extract it.
- Take the hopper at its bow-type handle to disposal and empty.
- Empty second dirt hopper as described above.
- Re-insert dirt hopper (Fig. 11/2) and fold down the bow (Fig. 11/3).

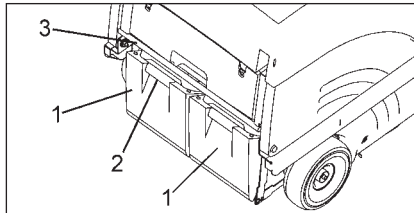

Fig.11

#### Emptying dirt hopper 980 E

- 1 Recessed grip in dirt hopper
- 2 Dirt hopper
- 3 Bow to lift/lower dirt hoppers



Clean dirt hoppers at regular intervals.

### 5.4 Empty Dirt Hopper of Sweepmaster B980 RH



Before emptying the turning property container the side broom and the turning roller are to be raised and switched off.



Broom and fan will be automatically switched ON upon lowering of the hopper if cylinder broom has been ON before lifting.



The driving speed forward and backwards with dug turning property container is reduced to 50 %, the turning roller is switched off.

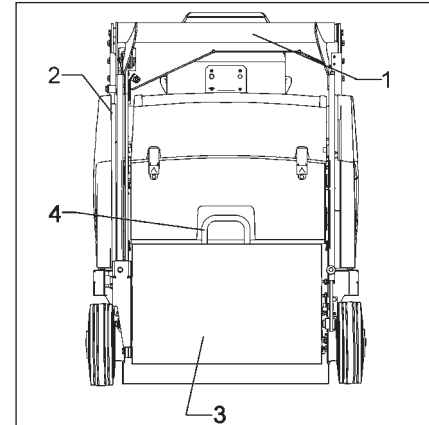

Fig.12

#### Emptying dirt hopper B980 RH

- 1 Lift-out arm
- 2 Lift-out cylinder
- 3 Dirt hopper
- 4 Handle

## Operation



Lift side brush and cylinder broom before removal of the dirt hopper.



Riding with the lifted hopper reduces stability of the machine significantly. For this reason, do not lift the hopper but just before emptying. Before lifting the hopper, the operator has to make sure that no persons or objects are behind or next to the machine. Stop the machine on level ground before lifting the hopper.



Keep clear of the hazard zone!



Pinching and shearing hazard. Provide for required safe distance before lifting or lowering the dirt hopper.

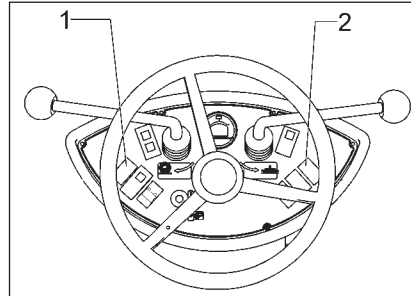

Fig.13

Sweepmaster B980 RH control panel

- 1 Release switch for lifted-up disposal function
- 2 Dirt hopper, lift and lower

Proceed to emptying of the dirt hopper as follows:

- Lift side brush and cylinder broom
- Proceed to shaking of the filter system
- Actuate switch (Fig. 13/1) and hold (dirt hopper is released)
- Actuate switch (Fig. 13/2) by pushing = lift dirt hopper
- Dirt hopper (Fig. 12/3) is lifted-out
- Back the Sweepmaster B980 RH until the dirt hopper is positioned above the container for disposal.
- Pull the safety knob (Fig. 14/1) of the release lever (Fig. 14/2).
- Release swinging of the dirt hopper by release lever (fig. 14/2).
- The Sweepmaster B980 RH away from the disposal container forward drive.
- Lower dirt hopper by actuating switch (Fig. 13/1) and switch (Fig. 13/2) = lower dirt hopper

## Operation



Observe the information given in paragraph 5.2 on releasing of lifted-up disposal.



Sweeping is possible only after the dirt hopper has attained its working position.

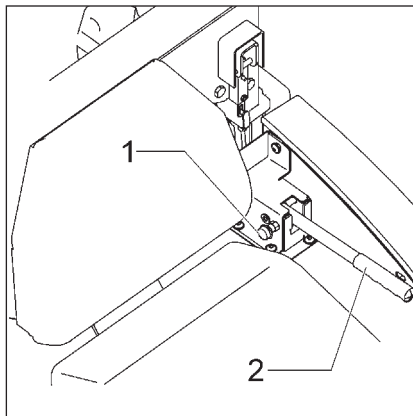

Release lever, swing dirt hopper

- 1 Safety knob
- 2 Release lever, swing dirt hopper



Should the dirt hopper not be completely emptied after swinging, proceed to manual shaking with the handle (Fig. 12/4).



Clean the dirt hopper in regular intervals.



Max. filling of the dirt hopper is 70 litres. Do not exceed a filling of 110kg.

## 5.5 Working With the Sweepmaster

The driver is requested to carefully read this operator's manual. All controls are marked with easy-to-understand symbols that ease familiarization. First driving attempts should be limited to clear areas until you are familiar with all controls and their functions.



**Please comply with the following safety provisions: When working with the Sweepmaster B980 R/RH all safety measures generally applicable for handling vehicles and fuels have to be observed. No passenger transport admitted with the Sweepmaster B980 R/RH. Warning and instruction labels attached to the machine contain important information about safe operation and guarantee your personal safety. Before commencing work,**



**the operator has to make sure that the machine and its accessories are in proper and safe condition and comply with the provision for safety at work. Do not operate the Sweepmaster B980 R/RH without protective devices.**

### 5.5.1 Switch Electro-Motor ON and OFF

**For safety reasons, the Sweepmaster B980 R/RH is equipped with a seat contact switch. Starting the engine or running engine is possible only when the driver is seated. If the seat contact switch is activated with the electro-motor running, reset by turning the key switch OFF and ON again.**

- Switch all levers and switches to neutral position.
- Actuate parking brake
- Turn key switch to "I"



**Check the drive pedal for being in neutral position before switching ON.**



**If the Sweepmaster B980 R/RH is not used within the admissible conditions and environments of use, the protective functions may respond and switch off driving function without prior warning.**

**Slow the machine down to standstill by the service brake in that case.**



**Acknowledge protective function by key switch.**



**Overheating of the travel drive assembly or control module always entails a cooling phase.**



**The seat contact switch deactivated all functions, driving function included. Slow the machine down to standstill by the service brake in that case.**

## Operation

### 5.5.2 Sweep

- Lower cylinder broom.
- Release parking brake.
- Slowly depress drive pedal until desired speed has been attained.
- Regularly actuate shaking device to clean plate filter.
- Check filling level of the dirt hopper and empty if required.

### 5.5.3 Stop and Park

- Release drive pedal which returns automatically into its neutral position and the machine slows down to standstill and actuate service brake.
- Actuate parking brake
- Lift side brush and cylinder broom
- Turn key switch to "0"



**When leaving the machine unattended, pull key.**

### 5.5.4 Displace

Make sure that the key switch is in neutral position and the side brush and cylinder broom are lifted up before displacement of the machine.

### 5.5.5 Transport

Before transporting the machine on other vehicles, engage the parking brake and secure the machine by straps and by placing wedges at the wheels.



## Technical Data

B980 R/RH

Sweepmaster		B980 R(6502.40)	B980 RH(6502.60)
<b>Filter system</b> Filtering surface Plate filter	m <sup>2</sup> qty.	2,8 1	2,8 1
<b>Cylinder broom</b> Length/diameter Wearing limit Speed Sweeping track Quantity of bristle rows Serial bristling	mm mm rpm mm	345 / 700 290 530 +/- 20 50 + 5 12 v-förmig PES	345 / 700 290 500 +/- 20 50 + 5 12 v-förmig PES
<b>Bodenabstand der Dichtleisten am Besenraum</b> Ground clearance of sealing strips at broom compartment Sealing strips, left, right, rear Sealing strip, front	mm	1 / 1 / 4 rests upon the soil	1 / 1 / 4
<b>Side brushes</b> Diameter Speed Serial bristling	mm rpm	460 90 PES	460 90 PES
<b>Dirt hopper</b> Hopper capacity	litre	2x30	70

## Technical Data

Sweepmaster		B980 R(6502.40)	B980 R(6502.60)
<b>Tyres</b> Front drive wheel, bandage Rear, solid rubber tyres		Ø 300 / 90 4.00-4	Ø 300 / 90 4.00-4
<b>Electric drive</b> Service voltage Travel drive assembly (P1/P2) Suction fan motor/sweeping (P1/P2) Total power consumption (P1)		DC / V KW KW KW	24 0,8 / 1,0 1,0 / 1,25 2,4
<b>Hydraulic system</b> Compact unit (maintenance-free) Voltage  Hydraulic fluid, e.g.  Hydraulic tank, capacity		V   litre	24  DTE 15 M or equivalent  0,76



## Technical Data

		980 E (6502.40)	980 EH (6502.60)
<p><b>Noise emission</b> The sound pressure level measured according to DIN EN ISO 11201 and under standard operating conditions at the operator's ear with - operating status fan, cylinder broom and side brush ON amounts to</p> <p>The sound pressure level measured according to DIN EN ISO 3744 under standard operating conditions and maximum volume flow amounts to</p>	dB (A)	70	70
	dB (A)	82	82
<p><b>Vibrations</b> The frequency weighted acceleration measured according to EN 1033 which have an effect upon the upper limbs (hand-arm-system) amounts under normal working conditions</p> <p>The frequency weighted acceleration measured according to EN 1032 which have an effect upon the lower limbs (feet and seat) amounts under normal working conditions</p>	m/s <sup>2</sup>	< 2,5	< 2,5
	m/s <sup>2</sup>	< 0,5	< 0,5

## 7 Maintenance/Service

### 7.1 Maintenance Instructions

Compliance with our recommendations concerning maintenance work will give you the certitude of having an effective and dependable machine at your disposal.

It is better to take precautions than repairing damages - and it saves money!



**According to paragraph 57, BGV D29, the Sweepmaster B980 R/RH vacuum sweeper has to be inspected for safe condition by an authorized expert as required, but not less than once a year. Results of such an inspection have to be kept on file at least until the next inspection is performed.**

Please contact your local Hako distributor if you cannot do the maintenance works as prescribed in the maintenance schedule in-house. He will have these works done for you and has qualified personnel and genuine spare parts at disposal.



**When cleaning or servicing the machine, or replacing parts, have the motors stopped, the battery plug disconnected and the service brake (parking brake) engaged.**

In case of questions or orders for spare parts, please always quote your machine's serial indicated on the nameplate

Refer to chapter 1.3.1 Fig. 12 for position of nameplate.

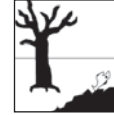

**Collect spilled oil and fuel and provide for adequate disposal of these substances.**

Use appropriate tools for servicing, maintenance and adjusting work only. Spare parts at least will have to be of the same quality as genuine parts are.



**Do not remove or install tires or repair a rim. Take the wheel and rim to a workshop where qualified personnel and the required specific tools are available.**



**Before commencing any work on the electric system disconnect the battery plug.**

## 7.2 Mount/Dismount Cylinder Broom

The cylinder broom is accessible from the left side of the machine and is to be dismantled as follows:

- Lower cylinder broom
- Pull ignition key and protect by engaging parking brake
- Open lateral flap
- Remove cover

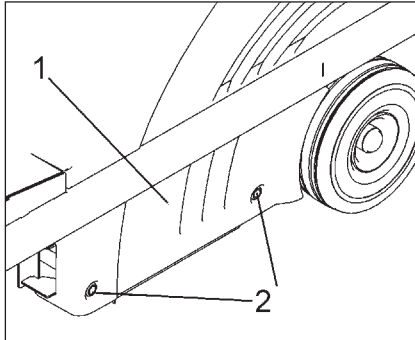

Fig.15

Remove cover

- Open locks (Fig. 15/2) by enclosed square spanner (counter-clockwise)
- Remove cover (Fig. 15/1)

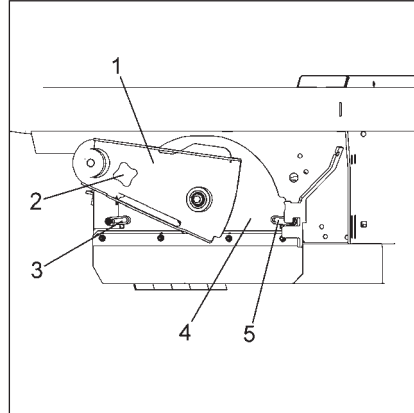

Fig.16

Dismount cylinder broom

- Loosen star-shaped knob (Fig. 16/2) and remove
- Remove cylinder broom seating (Fig. 16/1)
- Turn handle (Fig. 16/3 and 5) upwards and unlock

- Remove plate with sealing strip (Fig. 16/4)
- Remove cylinder broom by pulling.

Before commencing any work on the electric system disconnect the battery plug.

## 7.3 Adjust Sweeping Track

An adjustment device allows adaptation to the different sweeping conditions. The cylinder broom has to be adjusted for normal use and with regard to a low degree of wearing as described in the following. Check the broom adjustment on level ground as follows.



**Before checking:**  
Mark level surface for checking broom adjustment by chalk.

- Lower cylinder broom and let it run dry.
- Lift cylinder broom and forward the Sweepmaster B980 R/RH a bit. With the correct broom adjustment the parallel sweeping marks have to appear on the floor (sweeping track).

The sweeping track width is to be

- 50mm with the Sweepmaster B980 R
- 50mm with the Sweepmaster B980 RH

The sweeping track width can be adjusted by the star-shaped knob (Fig. 17/1) as follows:

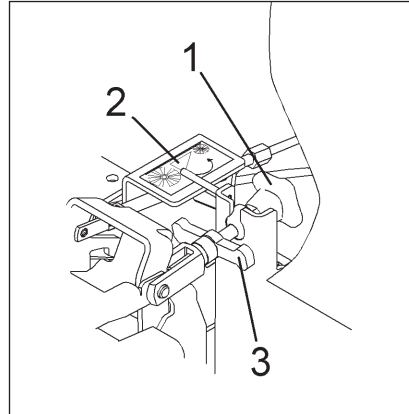

Fig.17

### Broom adjustment

- Open seat hood
- Loosen handle (Fig. 17/3)
- Turn star-shaped knob (Fig. 17/1) to the left = wider sweeping track to the right = smaller sweeping track
- Fix handle (Fig. 17/3)
- Sticker broom adjustment (Abb.17/2)



With one turn of the knob, the track widens or broadens by approx. 10mm.



When exceeding the sweeping track width, the engine protection may be activated.

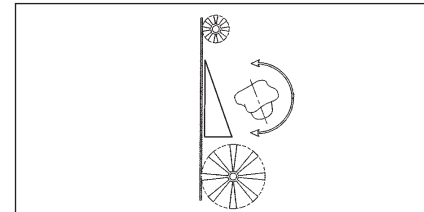

Fig.18

### Sticker broom adjustment

### 7.4 Sealing Strips for Broom Compartment

In order to assure good function of the sweeper, a perfect condition of the sealing strips is required, especially in order to attain the prescribed vacuum in the broom compartment, a clean sweeping result and the less possible wear of the sealing strips (check the sealing strips of the broom compartment for wearing and damages in regular intervals).

Replace defective sealing strips.

The ground clearance of the lateral and rear sealing strips is adjustable (oblong holes in the sealing strips).

Ground clearance =

sides: approx. 1mm

rear: approx. 4mm.

Proceed to adjustment with the battery set being mounted.

Height of the front sealing strip (folding apron) cannot be adjusted. Being dragged, it has contact with the floor.

### 7.5 Folding Apron Adjustment

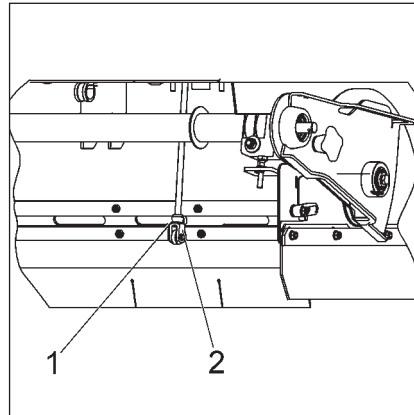

Adjust folding apron

- Turn engine off and pull key
- Disconnect battery plug
- Remove cover (as described in the paragraph "Mount/Dismount Cylinder Broom").
- Remove bolt (Fig. 19/2).
- Modify adjustment by turning the fork head (Fig. 19/1).



**Modify adjustment such that the cylinder broom does not retract the sealing strip of the folding apron during operation.**

Fig.19

### 7.6 Replace Side Brush

The side brush is located at the front right of the machine (standard version). Use the lever (Fig. 10/9) to lift and lower the side brush. The side brush is to be lightly inclined in forward and in outward direction. The swinging area of the side brush arm is limited by stop screws. The side brush is driven by a V-belt. Fitting of a second side brush for specific appliances is possible.

Proceed as follows for dismounting of the side brush:

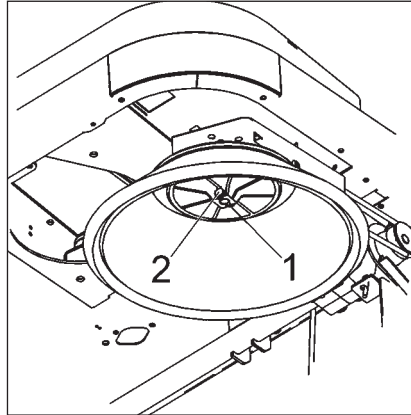

**Replace side brush**

**Fig.20**

Proceed in inverse order for mounting of the side brush.

- Turn engine off and pull key.
- Secure machine by engaging parking brake
- Disconnect battery plug
- Side brush lifted
- Loosen hexagonal nut (Fig. 20/1) und remove together with washer
- Remove bolt (Fig. 20/2)
- Remove side brush

### 7.7 Dismount Plate Filter

Proceed as follows for dismounting of the plate filter:

- Open seat hood.
- Open quick-release locks (Fig. 21/1).
- Remove cover, filter case (Fig. 21/3)
- Remove covering hood, plate filter
- Loosen fillister head screws (Fig. 21/2) and remove.
- Fold back frame with electro-motor (Fig. 22/3).
- Hook frame at indicated position (Fig. 22/4)
- Remove plate filter (Fig. 22/5).

For mounting of plate filter proceed in inverse order.

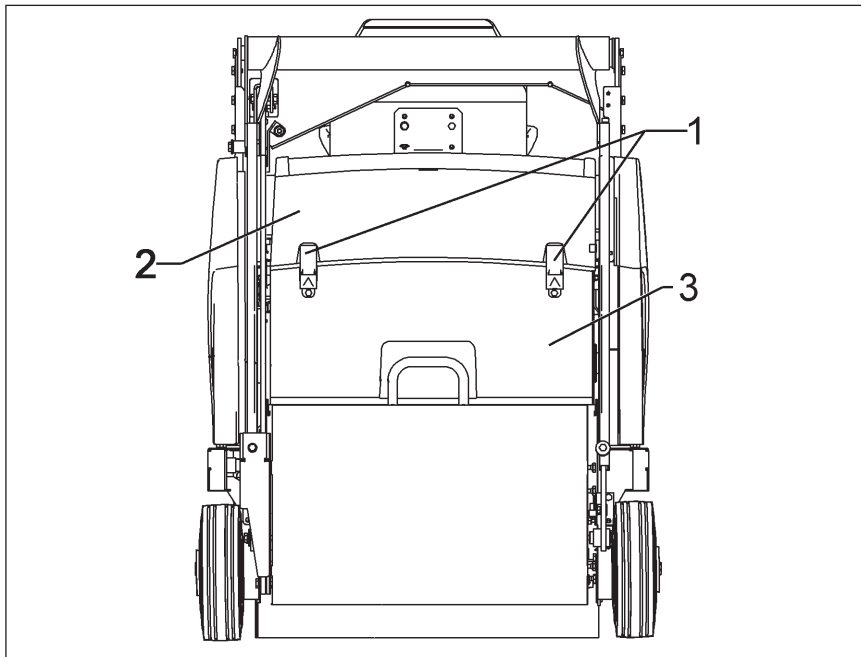

Replace plate filter

- 1 Quick-release locks
- 2 Filter case cover
- 3 4 Filter case

Fig.21

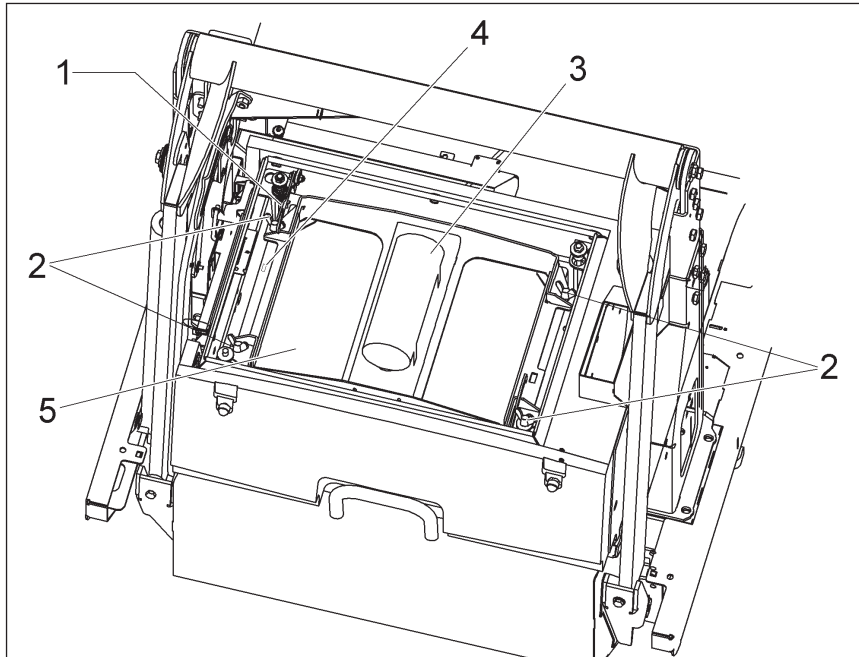

Fig.22

Plate filter

- 1 Detent hook
- 2 Wing screws
- 3 Frame with electro-motor
- 4 Opening for detent lever
- 5 Plate filter



### 7.8 Basic Cleaning of Plate Filter

Hold the plate filter (Fig. 23/1) in vertical position and let it fall down from a height of 1 m to the even floor as represented in Fig. 23.

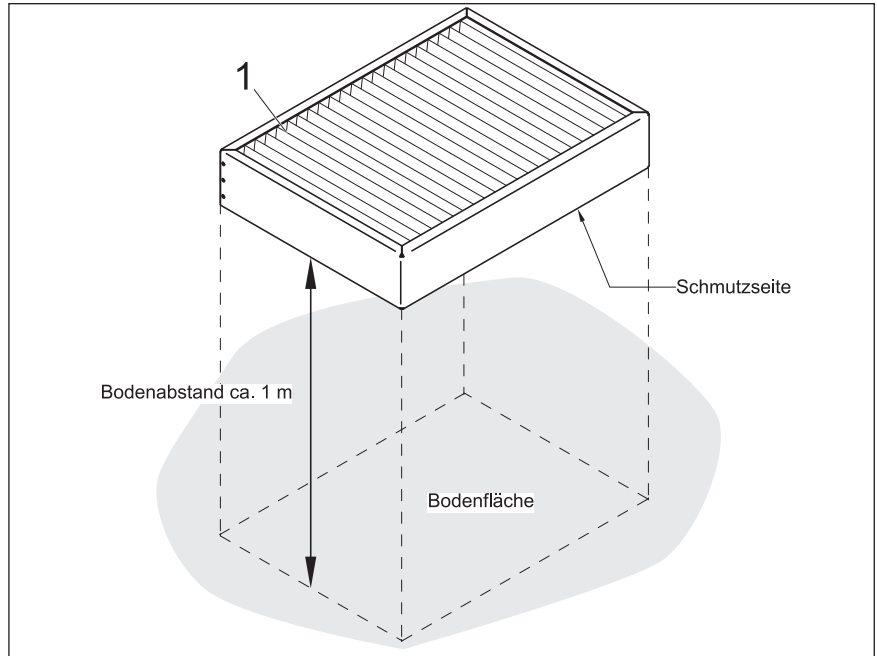

Basic cleaning of plate filter

1 Plate filter

Fig.23

**7.9 V-Belt Drive  
Sweepmaster B980 R/RH**

- 1 Tensioning roller
- 2 Suction fan V-belt (20Hz)
- 3 V-belt pulley
- 4 V-belt for cylinder broom and side brush (130 Hz)
- 5 Side brush V-belt
- 6 Belt pulley
- 7 Cylinder broom V-belt
- 8 Tensioning roller lever
- 9 Belt pulley
- 10 Tension spring
- 11 Hexagonal nut
- 12 Hexagon socket screw
- 13 Screws

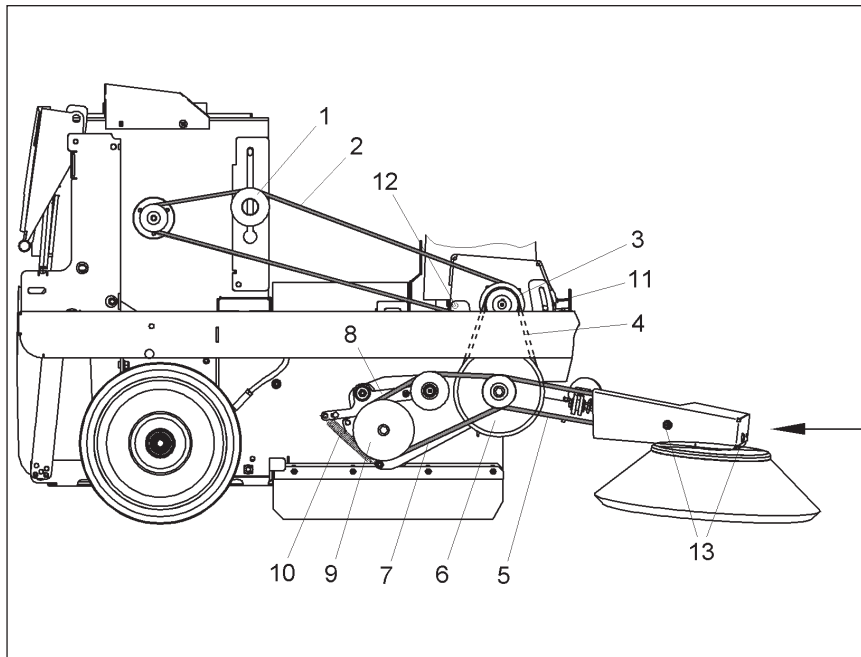

V-belt drive Sweepmaster B980 R/RH

Fig.24

## Maintenance/Service

### 7.9.1 Replace Cylinder Broom V-Belt

- Turn engine off and pull key.
- Secure machine by engaging parking brake
- Disconnect battery plug
- Detent tensioning spring (Fig. 24/10) by left hand while taking the V-belt off the tensioning roller with right hand
- Remove V-belt (Fig. 24/7)

Proceed in inverse order for mounting of the side brush.

### 7.9.2 Replace Side Brush V-Belt

- Turn engine off and pull key.
- Secure machine by engaging parking brake
- Disconnect battery plug
- Remove bottom right cover (turn locks counter-clockwise by square spanner).
- Remove cylinder broom V-belt (as described in paragraph "Replace Cylinder Broom V-Belt")
- Loosen screws (Fig. 24/13) at the cover plate and remove

- Remove cover plate
- Push side brush in direction of the machine to detent V-belt (Fig. 24/5)
- Remove V-belt (Fig. 24/5)

Proceed in inverse order for mounting of the V-belt.

### 7.9.3 Replace Suction Fan V-Belt

- Turn engine off and pull key.
- Secure machine by engaging parking brake
- Open seat hood
- Disconnect battery plug
- Open quick-release locks (Fig. 21/1)
- Remove filter case cover (Fig. 21/3)
- Loosen screws at the inside of the right lateral fairing and remove
- Tilt lateral fairing lightly to the outside, the remove by pulling upwards
- Loosen tensioning roller (Fig. 24/1)
- Loosen hexagonal nuts (Fig. 24/11) and hexagon socket screw (Fig. 24/12) and detent V-belt (Fig. 24/4)
- Remove V-belt (Fig. 24/4) from V-belt pulley (Fig. 24/3)
- Remove V-belt (Fig. 24/2)

Proceed in inverse order for mounting of the V-belt.

Do not exceed tension of V-belt.



**Observe the following when mounting the V-belt: First adjust tension of V-belt (Fig. 24/4), the adjust tension of V-Belt (Fig. 24/2).**

### 7.10 Adjust Steering Chain Tension

Check the condition and function of steering chain every 200 hours of operation.

Proceed to adjustment of tension via a spring located in the pedal area and accessible after removal of the cover plate.

We recommend having this adjustment work done by qualified personnel only.



**Adjust tension of the steering chain such that rotational movement is possible without jerks.**

### 7.11 Check Hydraulic Fluid and Refill

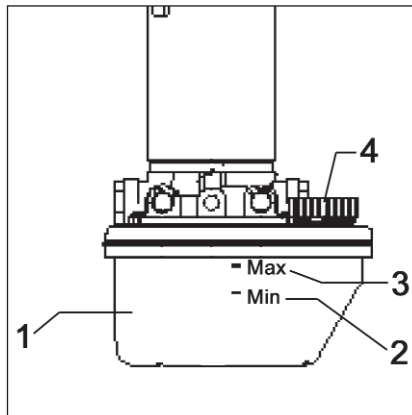

Fig.25

#### 7.11.1 Check Hydraulic Fluid

- Turn engine off and pull key
- Secure machine by engaging parking brake
- Open seat hood
- Check hydraulic fluid level at tank (Fig. 25/1), the level must not fall below the minimum mark (Fig. 25/2) and maximum mark (Fig. 25/3).

#### 7.11.2 Refill Hydraulic Fluid

- Remove cover (Fig. 24/4) and refill hydraulic fluid
- Close hydraulic fluid tank with cover

Use DTE 15M hydraulic fluid or a fluid of similar quality.

## 7.12 Electric System

### 7.12.1 Fuses/Relays

1 F2	Pre-fuse	(20A)
2 F3	Travel drive assembly control	(10A)
3 F4	Control panel indicators	(5A)
4 F5	Horn	(5A)
5 F6	Control, main motor and LDS	(5A)
6 F7	LDS measurement	(5A)
7 F8	Lighting	(7.5A)
8 F9	Lifted-up disposal control (6502.60)	(7.5A)
9 F10	Vacuum cleaner option	(30A)
10 F11	Shaking motor	(30A)
11 F14	Flashlight option	(5A)
12 K4	Time relay, filter monitoring	
13 K5	Impulse relay, shaking	
14 F12	Main motor	(63A)
15 F1	Travel drive assembly	(63A)
16 K1	Relay, multimode	
17 K12	Relay	
18 K3	Relay	
19 K2	Relay, motor suction fan/ sweeper	

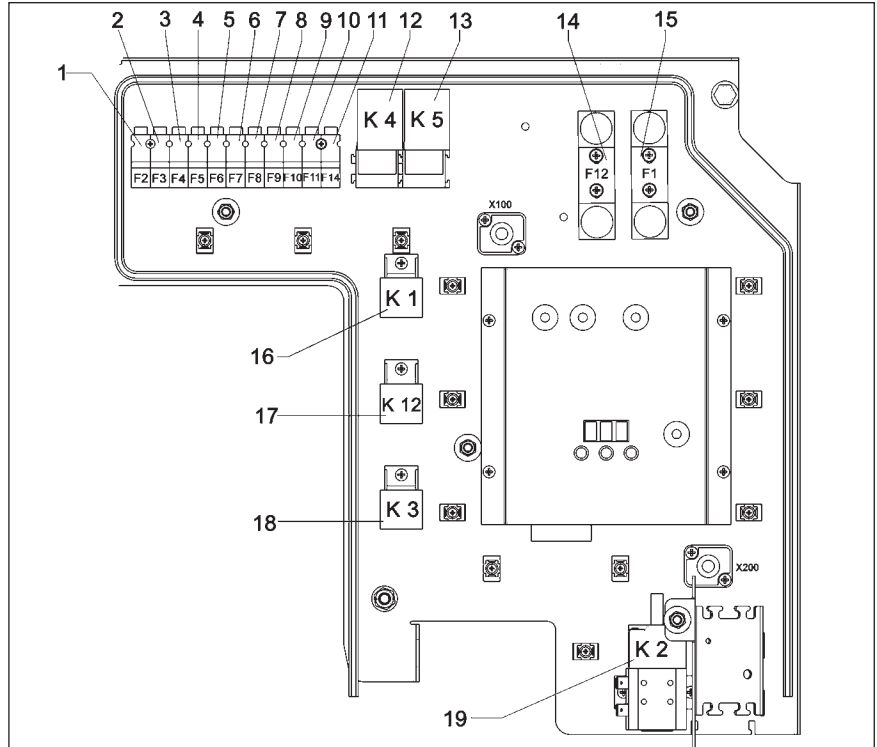

Fuses/relays

Fig.26

## Maintenance/Service

### 7.12.2 Lifted-Up Disposal Fuses/Relays

20	K6	Lifted-up disposal
21	K7	Lifted-up disposal
22	K8	Lifted-up disposal
23	K9	Lifted-up disposal
24	K10	Relay, lift dirt hopper
25	K11	Relay, lower dirt hopper
26	F 13	Hydraulic unit (30A)

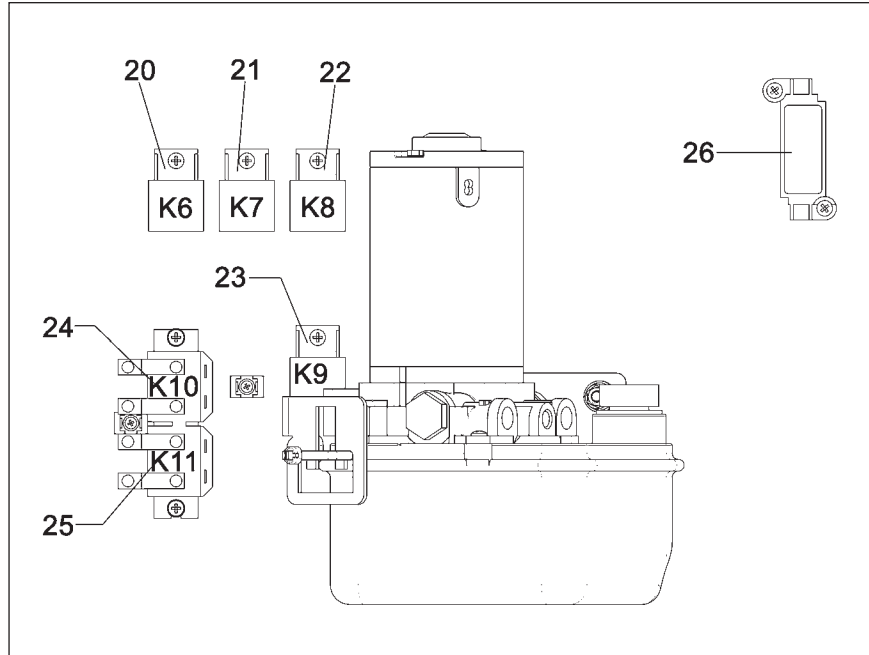

Lifted-up disposal fuses/relays

Fig.27

Maintenance/Service				
7.13 Sweepmaster B980 R/RH Maintenance Schedule (6502.40/60)	Daily	after first	hours of operation	
			every 100	every 200
Check batter acid level and top with distilled water if required (with fully charged battery only)	X			
Check acid density of battery			X	
Clean battery poles and grease			X	
Check cables for damages and screwed connections for tight fit				X
Check function of seat contact switch				X
Visual check of front tires			X	
Check cylinder broom for wearing or foreign particles (e.g. wire, straps) and replace broom if required	X			
Check sweeping track and adjust if required			X	
Check sealing strips at the broom compartment, adjust if required or replace defective sealing strips			X	
Check sealing strips at dirt hopper, replace defective sealing strips				X
Check side brush adjustment and brush bristles for wearing, adjust if required or replace side brush			X	
Check V-belt for wearing and correct tension and re-adjust if required		5	X	

Maintenance/Service				
7.13 Sweepmaster B980 R/RH Maintenance Schedule (6502.40/60)	Daily	hours of operation		
		after first	every 100	every 200
Visual check of V-belts	X			
Check service/parking brake and re-adjust if required			X	
Check filter system for tightness (visual check)			X	
Dismount plate filter and clean if required			X	
Clean travel drive assembly, brush drive, shaking motor			X	
Check tread of wheels				X
Check function of electro-motor, carbon brushes for smooth operation and wearing; clean motor from carbon dust and replace carbon brushes if required		500		X
Check carbon brushes of travel drive assembly (to be executed by qualified personnel only)		500		X
Check hydraulic hoses and replace if required				
Check hydraulic fluid level for lifted-up disposal and refill if required			X	
Check tensioning moment of fixing screws for lifted-up disposal facility and re-tighten if required (49 Nm)		5	X	
Check tension of steering chain and re-adjust tension if required				X



## Special Equipment

### 8 Special Equipment

Designation	Description		Order no.
Solid rubber tyres	Set of puncture-safe SE-Superelastic tyres 4.00-4, leaving no traces (2wheels on rim)		6521
L-h side brush system			6507
Protective roof			6504
Flashlight	For mounting on protective roof or direct cultivation		6505
Vacuum cleaner	24V version		6509
Comfort seat	Seat features adjustable cushioning provided		7093
Lighting system	Including two front and two rear lights, rear and lateral reflectors (according to German StVZO §66a)		6506

# Sweepmaster B980 R/RH

## Changes Due to Machine Directive 2006/42/EC

The Hako logo consists of the word "Hako" in a bold, italicized, orange sans-serif font. A thick orange horizontal line is positioned above the letters, extending from the left edge of the 'H' to the right edge of the 'o'.

**Clean ahead**

### **Preface**

Modified text in paragraph Preface:  
Before using the equipment for the first time, read this original manual thoroughly, act according to the information contained and keep it in a safe place for future reference or subsequent owners.

### **Intended use**

Modified text in paragraph Intended Use:

Based on the conception, design and construction of the model introduced onto the market by us, the machine complies with the applicable basic safety and health requirements stipulated in the EC Directive (refer to Declaration of Conformity). This declaration is no longer considered valid in the event of modifications to the machine not authorized by us. The manufacturer is not deemed liable for any damage resulting from unauthorized modifications to the machine.

### **General safety information**

The machine may be used only for operation on plane areas with a maximum inclination of up to 12 %.

### **Disposal**

New text in Chapter Introduction:  
Render the machine inoperable. It must not represent a potential source of danger for children.

Dispose of the device according to the applicable local regulations. For further information on handling and recycling, please contact your authorized Hako dealer where you purchased the device.

Used batteries with the recycling symbol contain reusable commodities. The heavy metals contained simultaneously represent a serious risk to health and to the environment. Never open batteries or damage them. Never touch, inhale or swallow any material inside batteries. Health hazard! Never allow batteries to pollute the environment. Risk of contaminating the ground and water! In accordance with the symbol with the crossed out bin, these batteries must not be disposed of in domestic waste. The return and recycling of old batteries must be agreed on with your authorized Hako dealer in accordance with the Battery Law § 6 and § 8 (BattG)

### **Noise emission value**

The sound pressure level (LpA) (at the ear of the operator) measured according to DIN IEC 60335-2-72 under normal working conditions: 77 dB (A)

Measurement inaccuracy (KpA):  
2 dB (A)

Sound power level (LwAd) measured according to DIN EN 60335-2-72 under maximum working conditions:  
91 dB (A)

Sound power level (LwAd) measured according to 2000/14/EG under maximum working conditions:  
91 dB (A)

### **Vibration**

The weighted effective value of acceleration, measured in accordance with ISO 5349-1, to which the upper parts of the body (hand-arm) are exposed under normal working conditions:  
< 2,5 m/s<sup>2</sup>

The weighted effective value of acceleration, measured in accordance with ISO 2631-1, to which the upper parts of the body (feet-seat) are exposed under normal working conditions:  
< 0,5 m/s<sup>2</sup>

## EC Declaration of Conformity (corresponds to EC Directive 2006/42/EC)

**Hako GmbH**  
**Hamburger Straße 209-239**  
**D-23843 Bad Oldesloe**

declares that the products

**Sweepmaster B980 E, Typ: 6502.40**  
**Sweepmaster B980 RH, Typ: 6502.60**

to which this declaration relates, conform to the relevant provisions of the safety and health requirements stipulated in EC Directive 2006/42/EC and is in accordance with 2014/33/EC and 2014/53/EC.

Reference was made to the following standards and/or norms and/or technical specifications to ensure proper implementation of the safety and health requirements in the EC Directive:

**EN 60335-2-72**  
**EN 55012**  
**EN 61000-6-2**

Bad Oldesloe, 23.01.2018



Ricardo Ruiz Porath  
Product line Manager  
Cleaning Technology

Name of the authorized person who compiles technical documents for Hako:

Ludger Lüttel

## Maintenance Document

<p><b>100 operating hours Maintenance</b> Workshop stamp</p> <p>carried out on _____ at _____ operating hours</p>	<p><b>200 operating hours Maintenance</b> Workshop stamp</p> <p>carried out on _____ at _____ operating hours</p>	<p><b>300 operating hours Maintenance</b> Workshop stamp</p> <p>carried out on _____ at _____ operating hours</p>	<p><b>400 operating hours Maintenance</b> Workshop stamp</p> <p>carried out on _____ at _____ operating hours</p>
<p><b>500 operating hours Maintenance</b> Workshop stamp</p> <p>carried out on _____ at _____ operating hours</p>	<p><b>600 operating hours Maintenance</b> Workshop stamp</p> <p>carried out on _____ at _____ operating hours</p>	<p><b>700 operating hours Maintenance</b> Workshop stamp</p> <p>carried out on _____ at _____ operating hours</p>	<p><b>800 operating hours Maintenance</b> Workshop stamp</p> <p>carried out on _____ at _____ operating hours</p>
<p><b>900 operating hours Maintenance</b> Workshop stamp</p> <p>carried out on _____ at _____ operating hours</p>	<p><b>1000 operating hours Maintenance</b> Workshop stamp</p> <p>carried out on _____ at _____ operating hours</p>	<p><b>1100 operating hours Maintenance</b> Workshop stamp</p> <p>carried out on _____ at _____ operating hours</p>	<p><b>1200 operating hours Maintenance</b> Workshop stamp</p> <p>carried out on _____ at _____ operating hours</p>

Notes



# Advanced Technology for a Cleaner, Better Environment



Hako GmbH · Head Office · Hamburger Str. 209-239 · 23843 Bad Oldesloe · Germany  
Phone +49 4531 806-0 · Fax +49 4531 806-338