

B603 Series Intelligent Constant Pressure Water Supply Controller User Manual



CONTENT

I .PREFACE.....	I
II.SAFETY PRECAUTIONS.....	II
1. INSPECTION.....	1
1.1 Technology Features.....	1
1.2 Description of Name Plate.....	1
1.3 Selection Guide.....	2
1.4 Check the following point.....	3
2. EXTERNAL DIMENSION.....	3
3. ENVIRONMENTAL REQUIREMENT.....	4
4. WIRING.....	5
4.1 Control terminals overall connect.....	5
4.2 Wiring Main Circuits.....	6
5. OPERATION.....	7
5.1 Keypad Description.....	7
5.2 Operation Procedure.....	7
6. INSTRUCTIONS OF PARAMETERS GROUP.....	8
7. APPLICATION GUIDANCE.....	15
7.1 Single Pump Water Supply and Parameter Setting.....	15
7.1.1 System Wiring.....	15
7.1.2 Debugging.....	16
7.1.3 Parameter Setting of Single Pump Constant Pressure control Water Supply.....	16
7.2 Multi-pump Control.....	17
7.2.1 Typical System Wiring.....	17
7.2.2 Related parameter setting.....	18
7.3 Day-Part Water Supply Application Setting.....	19
7.3.1 System Wiring.....	19
7.3.2 Typical Application.....	19
7.3.3 Parameter Settings.....	20
7.4 Terminal Run/Stop Control Wiring and Setting.....	20
7.4.1 System Wiring.....	20
7.4.2 Operation.....	21
7.4.3 Settings.....	21
7.5 Manual/Auto Control Wiring and Setting.....	21
7.5.1 System Wiring.....	21
7.5.2 Operations.....	22
7.5.3 Settings.....	22
7.6 Electric Contact Gauge Water Supply.....	22
7.6.1 System Wiring.....	22
7.6.2 Electric Contact Pressure Gauge Adjust.....	22
7.6.3 Function Settings.....	22
7.7 Pumping Application.....	23
7.7.1 System Wiring.....	23
7.7.2 Example.....	23
7.7.3 Relating Parameter Setting.....	23
7.8 Application Summary.....	24
8. FAULT AND TROUBLE SHOOTING.....	25
9. MAINTENANCE.....	29
10. EPILOGUE.....	30

I .PREFACE

Thanks for choosing our product, we will supply you with considerate service as well as ever.

With high quality, multi-functional, low noise and strong commonality etc. characteristics, B603 multi-function energy-saving controller is suitable to full-automatic operation;

- Professional design based on users' needs, simplicity of operation and suitable for all kinds of applications,;
- According to the water condition to supply constant pressure water without manual operation after parameters were set correctly.
- Stop running automatically when no water consumption; Alarm automatically when faults occurred;
- Alternate running automatically in the multiple pump system, prolong the using life of pumps;
- Adapt to many kinds of input pressure signals;

II.SAFETY PRECAUTIONS

B603 is a new power electronic product, please read the operation manual carefully before using to keep your safety and make sure proper operation.

In this manual, the safety precautions were sorted to “WARNING” and “CAUTION”.



WARNING: Wrong using may result in death or serious personal injury.



CAUTION: Wrong using may result in the damage of controller or system.

WARNING

- Please don't dismantle, change the product, or may cause electric shock, fire hazard and personal injury;
- Please don't open the cover during the running of controller;
- Please don't put wire, bar of metal, filaments etc. into the controller so as not to cause a short circuit or get an electric shock;
- Please don't splash water or other liquid over the controller.



CAUTION

- Please don't make withstand voltage testing for the controller;
- Never connect AC power to output UVW terminals;
- If the internal components of the controller were influenced or damaged by static, please do not to touch;
- The motor, controller and power specifications should be matching, otherwise it could cause abnormal operation even burn out the device;
- If the controller appears serious vibration, noise, heat or peculiar smell in the first operation, please cut off the power immediately and contact suppliers or service center later;
- Please don't install the controller in the environment with direct sunlight, rain, frost or snow in case of deformation or damage.

Warm reminder:

For convenience, the controller has set default with a nonzero AI1 Feedback Lost Detecting Value, if here hasn't pressure signal feedback into the terminal AI1, the controller will be starting up failure and displaying “E022”, just take follows:

- ◇ If the controller worked as a master, please connect a transducer to the controller and then press the **STOP/RST** key;
- ◇ If it worked as an auxiliary, it should be setting as AI1 Feedback Lost Detecting Value(b02.08) 0 and then pressing the **STOP/RST** key to reset error warning.

1. INSPECTION

1.1 Technology Features

●Input & Output

- ◆ Input Voltage Range: 220/380V±15%
- ◆ Input Frequency Range: 47~63Hz
- ◆ Output Voltage Range: 0~rated input voltage
- ◆ Output Frequency Range: 0~50/60Hz

●I/O Features

- ◆ Digital Switch Input: 3 input
- ◆ Analog Signal Input: AI1:0~10V or 0~20mA input; AI2: 0~10V or 0~20mA input
- ◆ Relay Output: A pair of switch Output

●Function Characteristics

- ◆ Multi-Pump Control: Can realize 1 master and Max.5 auxiliaries combine work
- ◆ Sleep Function: Sleep down when have no water consumption, to earn a better energy saving
- ◆ Freeze-Proofing Function: Suitable to low temperature area, prevent pump from freezing
- ◆ Anti-clogging Function: take precaution against pipe clogging and clean the pipe dirt
- ◆ Power On Restart: Running automatically when power on
- ◆ Master Fault Shift Automatically: keep on working when the master break down
- ◆ Alternate Running: balance every pump's running time, prolong service life of the whole unit machine
- ◆ Day-Part Function: 3 independent day-part control, up to 7 day-part achieved when define separated
- ◆ Two Running Mode: synchronous control mode, master-slave control mode
- ◆ Terminal Control Mode: Terminal Run/Stop、Manual/Auto Control、Electronic Contact Gauge Control
- ◆ Various of water supply Fault Alarm Function: High-Pressure, Low-Pressure, Low-Level, Transducer Error etc.
- ◆ As many as 22 kinds of fault protection function: Over-Current, Over-Voltage, Low-Voltage, Phase-Failure, Over-Load etc.

1.2 Description of Name Plate

B603-4010

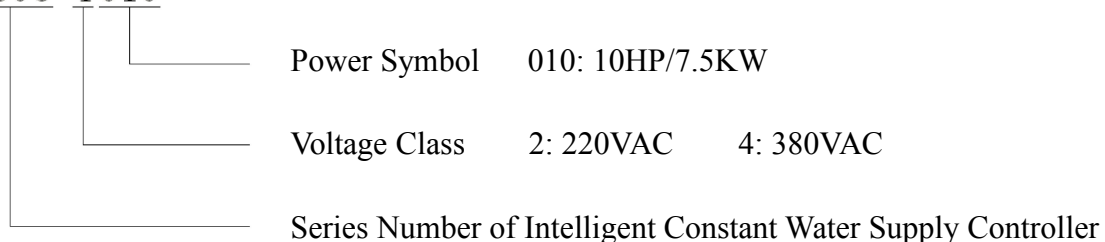

1.3 Selection Guide

Table1-3-1 B603 List

Model No.	Rated Input Voltage (V)	Rated Input Current (A)	Rated Output Current (A)	Motor Power (KW)	
B603-2001	1AC: 220V -15%~+15%	8.2	4.5	0.75	
B603-2002		14.2	7.0	1.5	
B603-2003		23.0	10	2.2	
B603-2001	3AC: 220V -15%~+15%	5.0	4.5	0.75	
B603-2002		7.7	7.0	1.5	
B603-2003		11.0	10.0	2.2	
B603-2005		17.0	16.0	3.7	
B603-2007		21.0	20.0	5.5	
B603-2010		31.0	30.0	7.5	
B603-2015		43.0	42.0	11	
B603-2020		56.0	55.0	15	
B603-2025		71.0	70.0	18.5	
B603-2030		81.0	80.0	22	
B603-2040		112.0	110.0	30	
B603-2050		132.0	130.0	37	
B603-2060		163.0	160.0	45	
B603-2075		200.0	200.0	55	
B603-4001		3AC: 380V -15%~+15%	3.4	2.5	0.75
B603-4002			5.0	3.7	1.5
B603-4003	5.8		5.0	2.2	
B603-4005	10.0		9.0	4	
B603-4007	15.0		13.0	5.5	
B603-4010	20.0		17.0	7.5	
B603-4015	26.0		25.0	11	
B603-4020	35.0		32.0	15	
B603-4025	38.0		37.0	18.5	
B603-4030	46.0		45.0	22	
B603-4040	62.0		60.0	30	
B603-4050	76.0		75.0	37	
B603-4060	90.0		90.0	45	
B603-4075	105.0		110	55	
B603-4100	140		150	75	
B603-4120	160		176	90	
B603-4150	210		210	110	
B603-4180	240		250	132	
B603-4215	290		300	160	
B603-4250	330		340	185	
B603-4270	370	380	200		
B603-4300	410	415	220		
B603-4340	460	470	250		
B603-4380	500	520	280		

Model No.	Rated Input Voltage (V)	Rated Input Current (A)	Rated Output Current (A)	Motor Power (KW)
B603-4430		580	600	315
B603-4470		620	640	350

1.4 Check the following point

- a) Inspect the nameplate and ensure it meets the order type and specification;
 - b) Inspect the entire exterior of the controller to ensure there are no scratches or other damage caused by the transportation;
 - c) Ensure the guarantee odd number matches the controller.
- If you have found any problem mentioned above, please contact the supplier.

2. EXTERNAL DIMENSION

2.1 The Dimension of B603

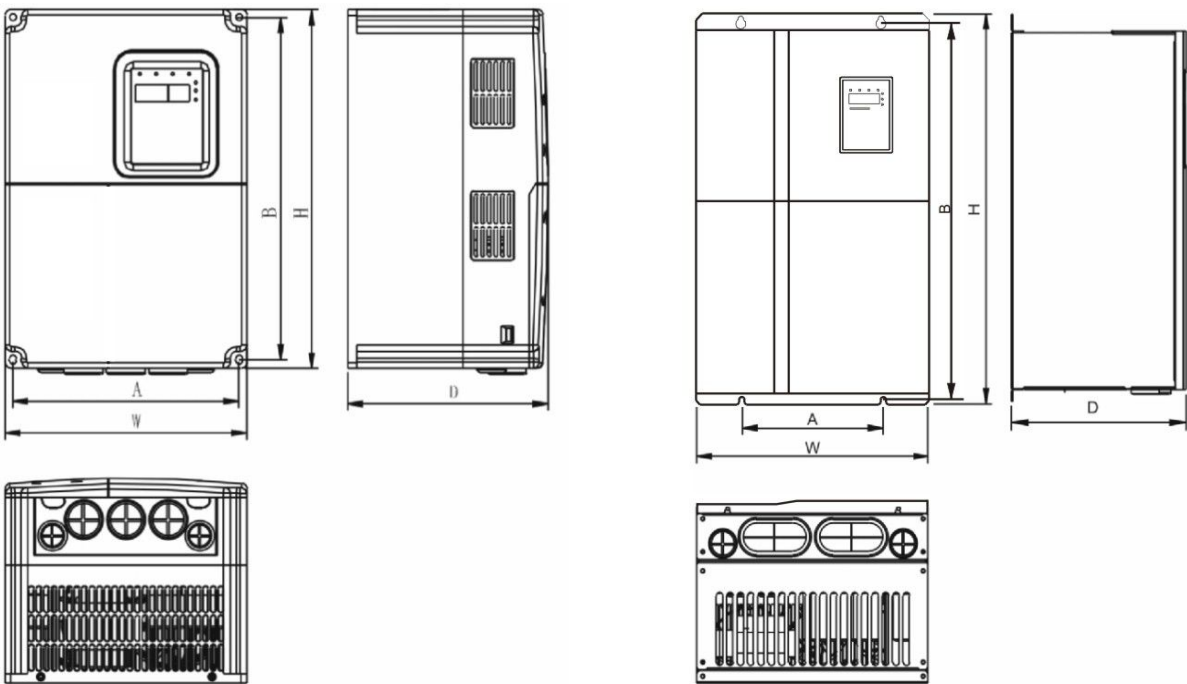

Figure2-1-1 Dimension (0.75~18.5KW)

Figure 2-1-2 Dimension (22~132KW)

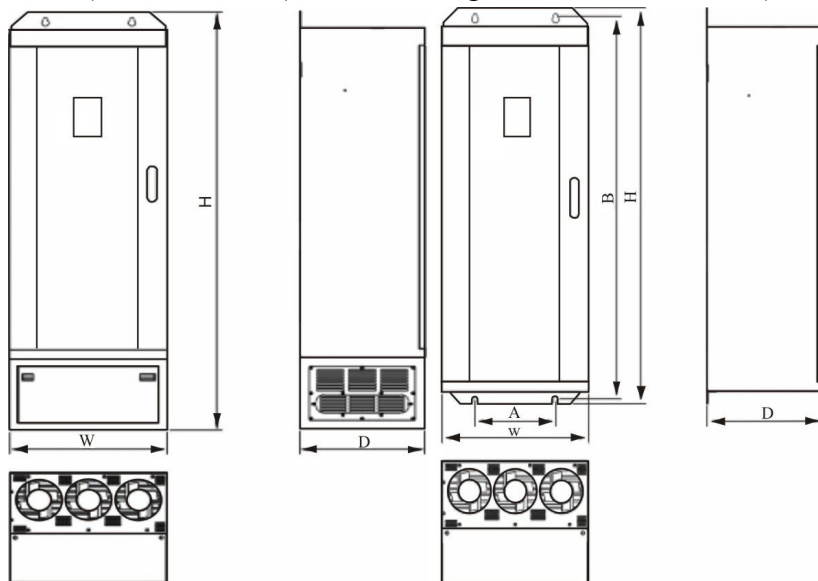

Figure 2-1-3 Dimension (160~350KW)

Model (KW)	A(mm)	B (mm)	H (mm)	W (mm)	D (mm)	Installation Hole
	Installation Dimension		External Dimension			
0.75~2.2	110.4	170.5	180	120	140	5
4~7.5	147.5	236	250	160	183	5
11~18.5	206	305.5	322	220	183	6.0
22~37	175	455	472	295	222	6.5
45~75	230	564.5	580	380	270	7.0
90~132	320	738.5	755	465	330	9.0
160~200 (Without base)	270	1233	1275	490	395	13.0
160~200 (With base)			1490	490	395	
220~350 (Without base)	500	1324	1358	750	402	12.5
220~350 (With base)			1670	750	402	

2.2 The Dimension of B603B

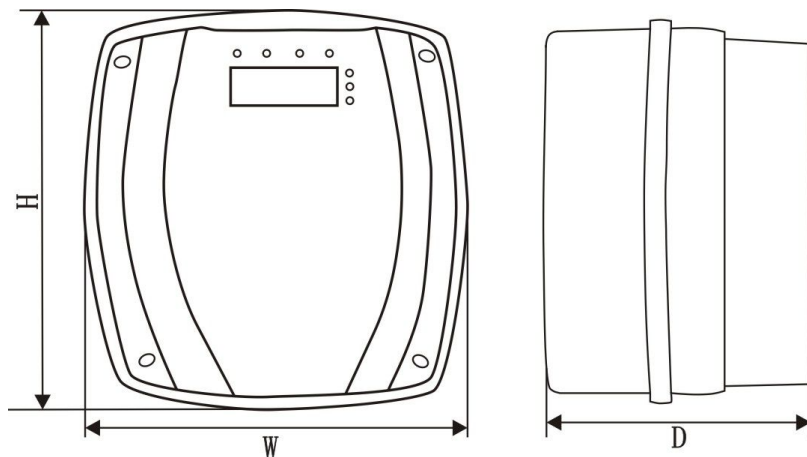

Figure 2-2-1 Dimension of B model

Model (KW)	A(mm)	B (mm)	H (mm)	W (mm)	D (mm)	Installation Hole
	Installation Dimension		External Dimension			
0.75~2.2(B model)	-	-	192	200	151	-

3. ENVIRONMENTAL REQUIREMENT

- 3.1 Environment temperature range: -10 °C ~+40 °C . Controller will be derated if ambient temperature exceeds 40°C.
- 3.2 Prevent rain drops, moist environment, oil fog, salt erosion, corrosive gas, etc.
- 3.3 Prevent direct sunlight, keep away from radiation source.
- 3.4 Prevent violent vibration or sudden impact.
- 3.5 Lower than 1000m installation altitude, it will be derated when the altitude is higher than 1000m.

CAUTION
<ul style="list-style-type: none"> When moving the controller please lift by its base and don't lift by the panel. Otherwise may cause the main unit fall off which may result in personal injury. Install the controller on the fireproofing material (such as metal) to prevent fire. When power off, should not install the controller until the power indicator light was extinguished, which can ensure the device has been discharged completely.

4. WIRING

4.1 Control terminals overall connect

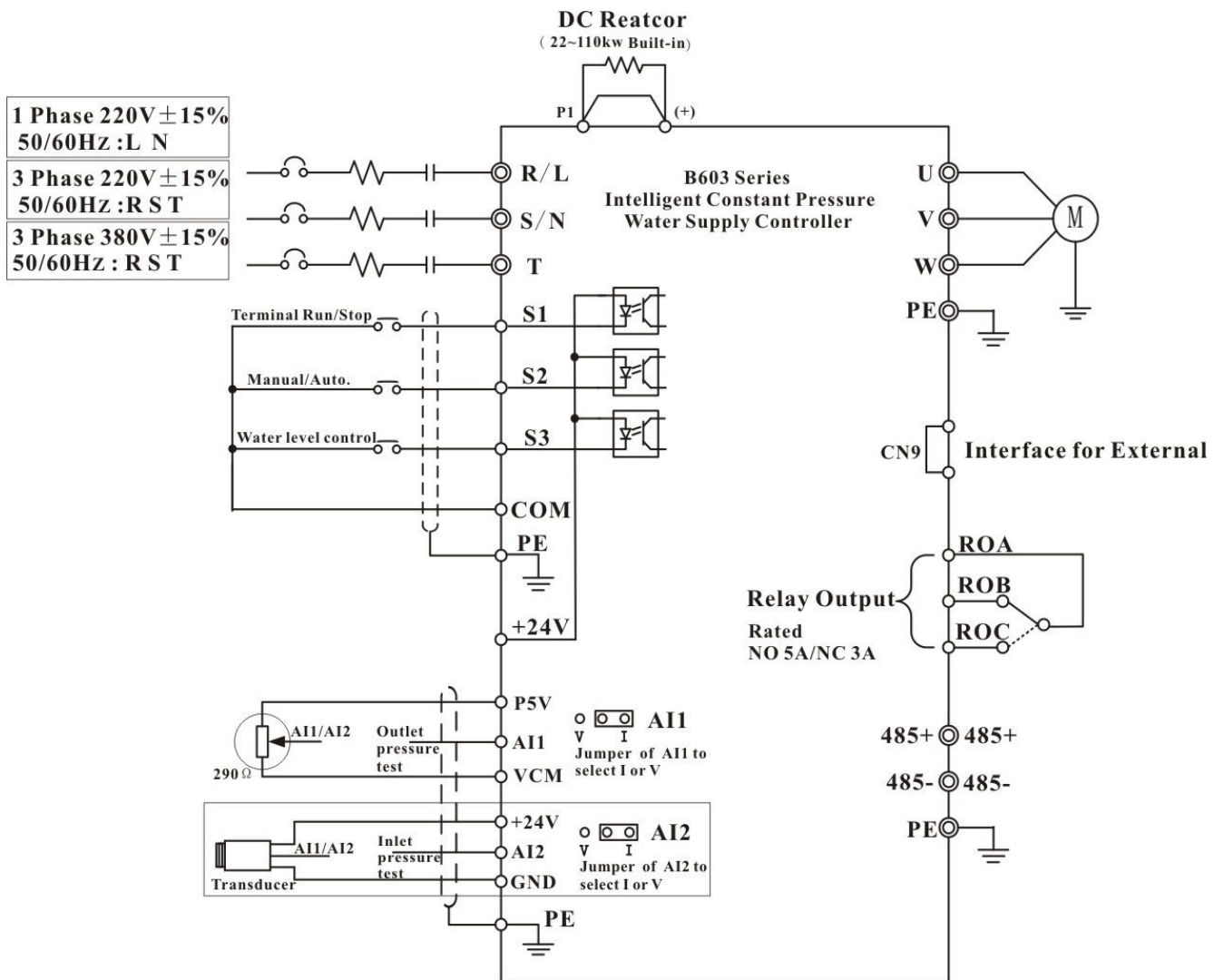

Figure 4-1- 1 wiring diagram

In order to keep safety and prevent electric shock and fire, PE must be grounded with ground resistance. Ground wire should be big and short, and it is better to use copper wire (>3.5 mm²). Furthermore, reliable grounding is the simplest, most effective and minimum cost solution for EMC problems, so it enjoys priority in all EMC methods.

4.2 Wiring Main Circuits

4.2.1 Wiring of main circuits

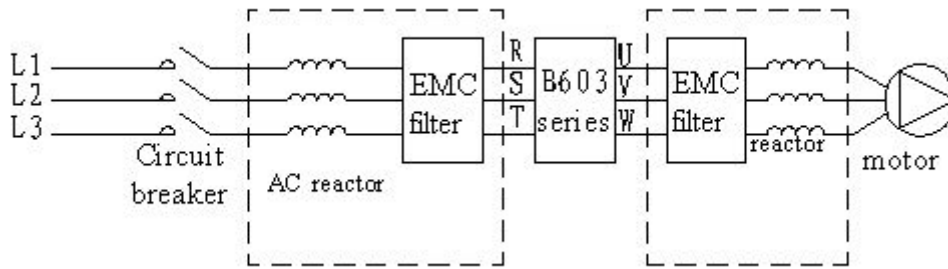

Figure4-2-1 High-Performance Main Circuit Wiring

4.2.2 Circuit breaker

It is necessary to connect a suitable circuit breaker between 3 phase AC power supply and B603 series intelligent constant water supply controller. The capacity of breaker is 1.5~2 times to the rated current of controller.

4.2.3 AC reactor (optional)

In order to prevent the rectifier damage resulted from the large current, AC reactor should be installed at the input side. It can also prevent rectifier from sudden variation of power voltage or harmonic generated by phase-control load.

4.2.4 Input EMC filter (optional)

EMC filter can minimize the interference of the surrounding device which may be disturbed by the cables when the controller is working.

4.2.5 Output EMC filter (optional)

EMC filter should be installed to minimize the leak current caused by the cable and minimize the radio noise caused by the cables between the controller and motor.

4.2.6 Output reactor

When the distance between the B603 controller and motor is more than 50m, the controller may be tripped by over-current protection frequently because of the large leak current resulted from the parasitic capacitance with ground. So as to avoid the damage of motor insulation, the output reactor should be installed.

4.2.7 Ground wiring (PE)

In order to keep safety and prevent electric shock and fire, PE must be grounded with ground resistance. Ground wire should be big and short, and it is better to use copper wire ($>3.5 \text{ mm}^2$).

Reliable grounding is the simplest, most effective and minimum cost solution for EMC problems, so it enjoys priority in all EMC methods.

5. OPERATION

5.1 Keypad Description

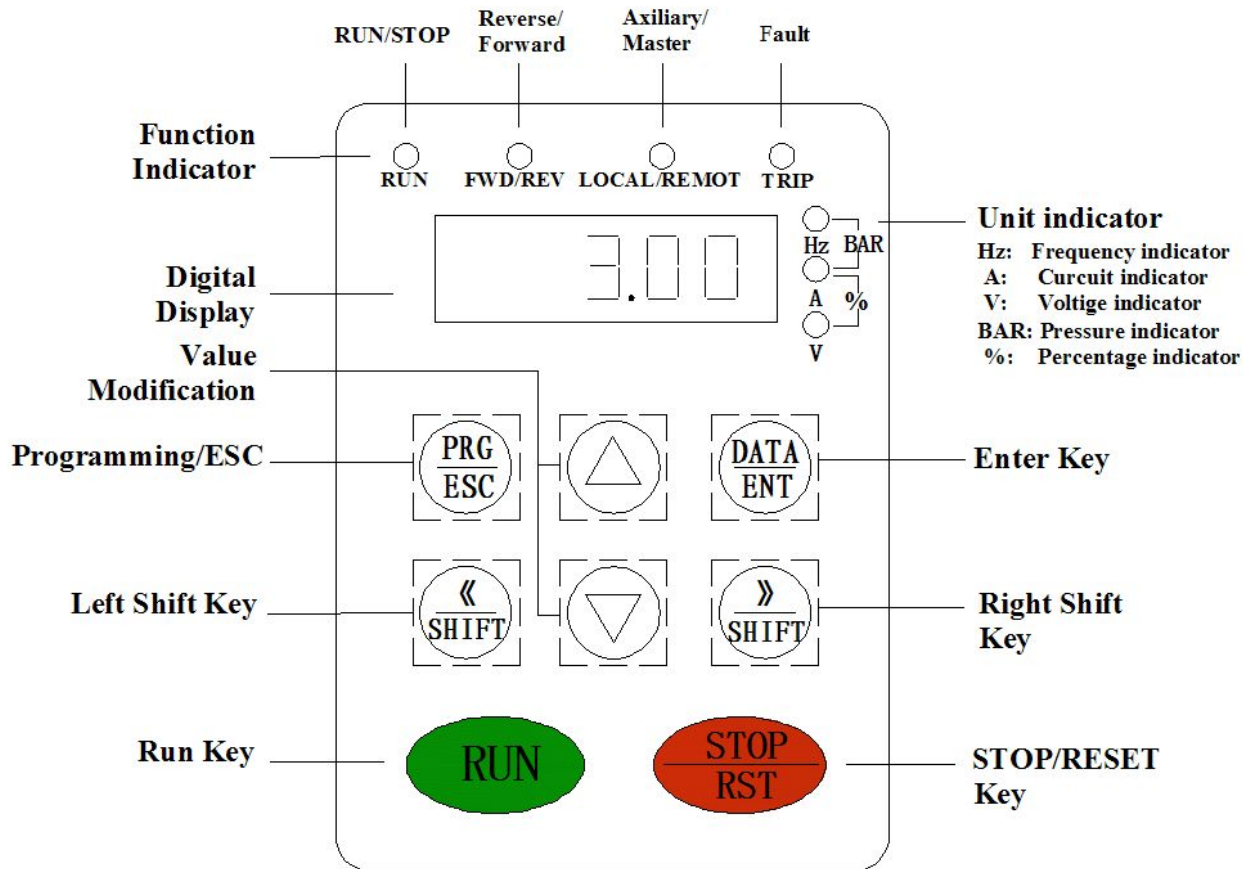

Figure5.1 Keypad schematic diagram

5.2 Operation Procedure

5.2.1 Power-on initialization

Firstly the system initializes during the controller power-on, and LED displays “b-603”. After the initialization is completed, the controller is on stand-by status.

5.2.2 Parameter setting

Three levels of menu are: 1. Function code group (first-level); 2. Function code (second-level); 3. Function code setting value (third-level)

- ▲ At the primary interface, press **<</SHIFT** or **>>/SHIFT** will switchover display running/stop status monitoring parameters;
- ▲ At the primary interface, press **PRG/ESC** will enter the first-level menu then press **PRG/ESC** will return to the primary interface;
- ▲ At the first-level menu, press **DATA/ENT** will enter the second-level menu. In second-level menu can also press **PRG/ESC** and **DATA/ENT** return to first-level menu or enter third-level menu;
- ▲ At third-level menu, press both **PRG/ESC** and **DATA/ENT** can return to the second-level menu, difference is: pressing **DATA/ENT** will save the parameters into the controller and return to the second-level menu with shifting to the next function code automatically; while pressing **PRG/ESC** will directly return to the second-level menu without saving the parameters, and keep staying at the current function code.

Example 1: Change factory pressure setting 3.0 bar to 2.5 bar

Method 1: Enter parameter setting

Operation flow chart:

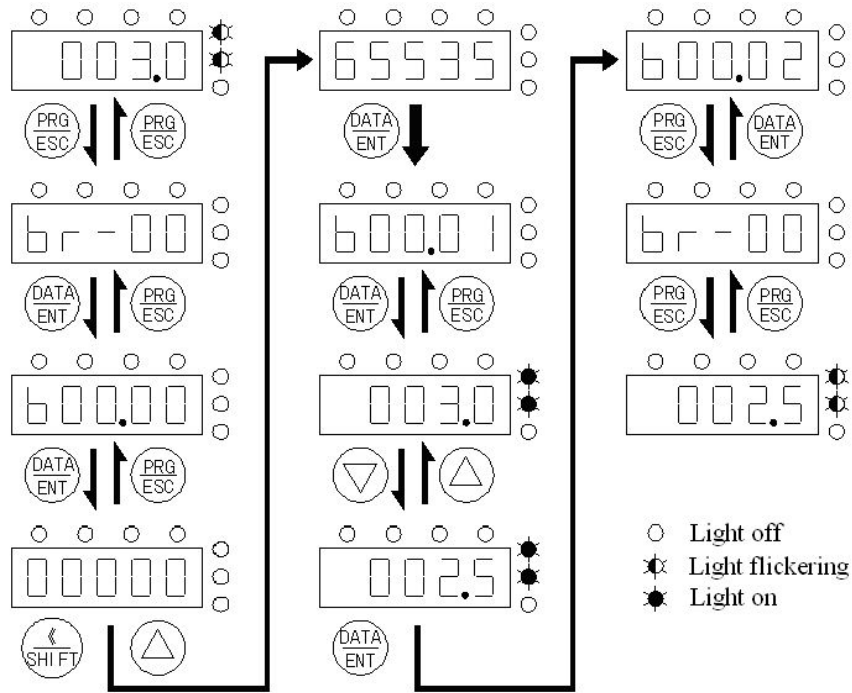

Figure 5-2-1 Operation Flow Chart

Method 2: Direct setting at the primary interface

Press Δ or ∇ at primary interface, the system will switchover to display setting pressure, press Δ or ∇ again, the setting pressure increase/decrease, mean while the system trace the setting pressure. After complete the pressure setting , please press **DATA/ENT** to save the value.

Example 2: During the running of controller, press **<</SHIFT** or **>>/SHIFT** to scroll through the parameters in left or right order until there are two upper lights on, can check the feedback pressure value.

6. INSTRUCTIONS OF PARAMETERS GROUP

Function Code	Name	Setting Range	Factory Setting	Description
Br00 Group Application Function				
b00.00	Debugging password	0~65535	65535	Decide by b06.09, default is 65535.
b00.01	Pressure setting value	0.0~100.0bar	3.0bar	Set according to the actual requirements of user
b00.02	Motor Rotating direction	0~1	0	0: forward 1: reverse
b00.03	Freeze-proofing	0~1	0	Used in cold areas 0: invalid 1: valid
b00.04	Anti-clogging	0~1	0	Prevention measures 0: invalid 1: valid
b00.05	Anti-clogging Rotating cycle	1.0~300.0s	20.0s	Set the forward/reverse rotating direction cycle and corresponding output frequency
b00.06	Anti-clogging Output frequency	0.00~600.00 Hz	15.00Hz	(should not be higher than the rated frequency of the pump) of anti-clogging.







Function Code	Name	Setting Range	Factory Setting	Description
Br01 Group Application Function				
b01.00	High Water Pressure/Level Alarm Value	0.0~100.0bar	8.0bar	When pressure is higher than this preset value, the controller halts, alarms and displays HP.
b01.01	Low Water Pressure/Level Alarm Value	0.0~100.0 bar	0.5bar	When pressure is lower than the preset value for a Low Pressure Running Time, the controller halts, alarms and displays LP.
b01.02	Low Pressure/Level Running Time	0~300s	20s	
b01.03	Minimum Freeze-proofing Frequency	1.00~30.00Hz	5.00Hz	Be valid when b00.03 was set to 1, whenever sleeps, running with the setting frequency in case of Freezing.
b01.04	Anti-clogging FWD./REV. Dead Time	0.0~3600.0s	1.0s	When anti-clogging is valid, b01.04 set the FWD./REV. transition time
b01.05	Maximum Transducer Setting Range	0.0~100.0bar	10.0bar	E.g. If the rated max. range of transducer is 10Bar, b01.05 should be set to 10.0
b01.06	AI1 Lower Limit	0.00~10.00V	1.00V	<p>•Lower limit use to Transducer Zero Setting</p> <p>•Higher limit use to accordant display and transducer pressure.</p> <p>•When display smaller than gauge, increase higher limit; When display greater than gauge, decrease higher limit.</p> <p>•When analog input is interfered, prolong Filtering time so as to increase the ability of anti-interference, but decrease the sensitivity.</p> <p>•Corresponding relationship of Transducer Parameter Setting:</p> 
b01.07	Corresponding Setting of AI1 Lower Limit	-100.0~100.0%	0.0%	
b01.08	AI1 Higher Limit	0.00~10.00V	5.00V	
b01.09	Corresponding Setting of AI1 Higher Limit	-100.0~100.0%	100.0%	
b01.10	AI1 Filtering time	0.00~10.00s	0.10s	
b01.11	AI2 Lower Limit	0.00~10.00V	1.00V	
b01.12	Corresponding Setting of AI2 Lower Limit	-100.0~100.0%	0.0%	
b01.13	AI2 Higher Limit	0.00~10.00V	5.00V	
b01.14	Corresponding Setting of AI2 Higher Limit	-100.0~100.0%	100.0%	
b01.15	AI2 Filtering time	0.00~10.00s	0.10s	

Figure6-1-1 Transducer Parameters

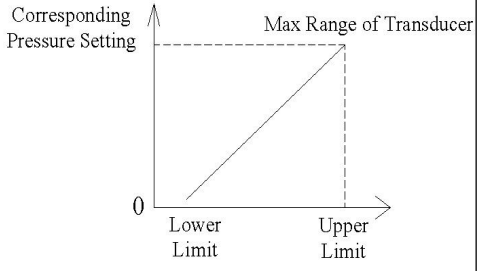
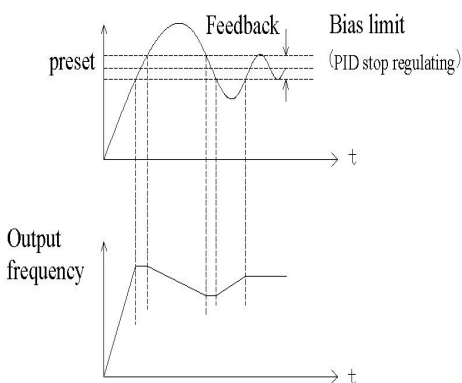
Function Code	Name	Setting Range	Factory Setting	Description
b01.16	Restart After Power-on	0~1	0	0:invalid 1:valid
b01.17	Control mode	0~1	1	0:synchronous 1:master-slave
Br02 Group Application Function				
b02.00	PID Source Selection	0~1	0	0:Keypad 1:Reserved
b02.01	PID Feedback Source Selection	0~1	0	0:A11 1:Reserved
b02.02	PID Output Characteristics	0~1	0	0:Water Supply 1:Pumping
b02.03	Proportional Gain (KP)	0.00~100.00	2.50	Determining the strength of PID regulation, KP is bigger, regulation is stronger, but fluctuate easier too.
b02.04	Integral Time (KI)	0.00~10.00	1.00	Bias between the Feedback and the Given, determining the speed of regulation, KI is bigger, regulation is stronger.
b02.05	Differential Time (KD)	0.00~10.00	0.00	Variable Ratio between the Feedback and the Given, KD is bigger, regulation is stronger.Be cautious use, for differential regulation amplifies interference of system.
b02.06	Sampling Cycle (T)	0.01~100.00s	0.10s	Calculating time of regulator, when increased, response sluggishly.
b02.07	PID Control Bias Limit	0.0~100.0%	0.0%	<p>Max. Bias of PID output value corresponding to closed loop given value:</p>  <p>Figure6-2-1 PID control curve Corresponding System Diagram of Max. Limit and Output Frequency. Properly set the value can regulate the accuracy and stability of PID system.</p>

Function Code	Name	Setting Range	Factory Setting	Description
b02.08	AI1 Feedback Lost Detecting Value	0.0~100.0%	1.0%	Transducer Fault Detecting Setting Value, corresponding to full range(100%), when the detecting time exceeds Feedback Lost time, it is deemed as malfunction by Transducer, the system will report E022 as Transducer Fault Code
b02.09	AI2 Feedback Lost Detecting Value	0.0~100.0%	0.0%	
b02.10	Feedback Lost Detecting time	0.0~3600.0s	1.0s	
Br03 Group Application Function				
b03.00	Communication Address	0~31	02	00: Master controller 01~05:Auxiliary controller 06~31:Reserved
b03.01	Baud Rate Selection	0~5	3	Data of master and auxiliary comes into the rate. 0:1200BPS 1:2400BPS 2:4800BPS 3:9600BPS 4:19200BPS 5:38400BPS
b03.02	Data Format	0~5	0	Data Format(Parity Check)
b03.03	Communication Delay Time	0~200ms	15ms	Interval of Data responding.
b03.04	Communication Timeout Delay 0.0: invalid	0.0~100.0s	0.0s	If the interval time exceeds the setting value, the system will report E018 as fault.
b03.05	Communication Error Action	0~1	0	0: Halt and alarm 1:Don't alarm and continue
b03.06	Communication Response Action	0~1	0	0: Responding to Write Operation 1: Un-responding to Writer Operation
b03.07	Data Transmission Time Interval	0.05~2.00s	0.10s	Ensure the effects of Data Transmission, long-time setting will slow down Data Transmission and short-time setting will easily make mistakes.
b03.08	Auxiliary Quantity	0~5	0	0:none
b03.09	Fault Shift	0~2	2	Fault Master Shift ●Invalid: Factory Setting ●Valid: Master set as 0; Axiliary1 set as 1. Remarks: Fault Shift demands the Axiliary1 to connect a backup transducer.

Function Code	Name	Setting Range	Factory Setting	Description
Br04 Group Application Function				
b04.00	Sleeping Function	0~1	1	No consuming auto stop. 0:Invalid 1:Valid
b04.01	Sleeping Waiting time	0.0~300.0s	5.0s	Delay time, seconds unit
b04.02	Sleeping Test	0.0~10.0%	4.0%	Water consuming test frequency rate.
b04.03	Wake-up Pressure Bias	0.0~20.0bar	0.5bar	During sleeping the wake-up pressure bias, e.g. the setting value(L)=3.0Bar, Bias(b04.03)=0.5bar, Practical pressure (P)<L-0.5=2.5bar, the pump will restart again.
b04.04	Sleeping Bias	0.0~1.0bar	0.0bar	The pressure fluctuation which allows sleeping
Br05 Group Application Function				
b05.00	Water Level Control	0~2	2	Water level switch style, 0: invalid 1: NC 2: NO
b05.01	Low Lever restart Delay Time	0~300min	1min	Delay time of restart after water level switch recover.
b05.02	Terminal S1S2 Control	0~3	2	0: invalid 1: Electric contact control  on: Frequency rise  on: Frequency drop 2: Manual/auto control  off: auto control  on: manual control 3: Terminal run/stop  on: Run  off: Stop  off: auto control  on: manual control
b05.03	Acceleration Time	0.1~3600.0s	Model Set	The setting time from max. Frequency to zero.
b05.04	Deceleration Time	0.1~3600.0s	Model Set	The setting time from zero to max. Frequency
b05.05	Maximum Output Frequency	10.00~600.00 Hz	50.00Hz	Determine the Acc./Dec. rate
b05.06	Up limit of Output Frequency	b05.07~b05.05 (Maximum Frequency)	50.00Hz	Maximum running frequency
b05.07	Lower Limit of Output Frequency	0.00Hz~b05.07	20.00Hz	The minimum running frequency of pump.

Function Code	Name	Setting Range	Factory Setting	Description
b05.08	Carrier Frequency	1.0~15.0kHz	Model Set	Use to ameliorate the noise of motor and controller's interference to the surroundings. A high carrier makes a low motor noise, but leads to a big temperature rise and interference. Should not be altered if unnecessary.
b05.09	Low Pressure(LP) Restart Delay Time	00~60min	10min	In case of Low Pressure, BR5.09≠0, the controller restarts to work according to the setting time automatically, without artificial restart. BR5.09=0, restart invalid.
b05.10	Alternating Time	0.00~300.00h	8.00h	In order to balance and prolong the pump service life to set the parameter, Unit: hour. When the parameter is set to 0.0, it means in-execution. Operational time of master and auxiliary pump switches over according to the setting Alternating Time.
Br06 Group Application Function				
b06.00	Running Status Display Selection	0~0x1FF	0x01F	bit0: Operational Frequency bit1: Pressure tested value bit2: Pressure setting value bit3: Output Current bit4:Bus Voltage bit5:Output Voltage bit6:Present Time bit7: Inlet Pump Pressure bit8: Input Terminal Status
b06.01	Stop Status Display Selection	0~0x1FF	0x00F	bit0: Pressure setting value bit1: Pressure tested value bit2: Giver Frequency bit3: Bus Voltage bit4: Input Terminal Status bit5:Output Terminal Status bit6:All Input Voltage bit7: Inlet Pump Pressure bit8: Present Time
b06.02	Keypad Display Selection	0~3	3	0:External Keypad Prior Enable 1:Both Display Enable, Only External Keypad Control; 2:Both Display Enable, Only

Function Code	Name	Setting Range	Factory Setting	Description
				Onboard Keypad Control; 3:Both Display Enable and Keypad Control.
b06.03	Relay Output Selection	0~4	0	0:Error or External Fault 1:Forward Running 2:Frequency Reaching 3:Stop Status 4:Lower Limit of Output Frequency Reaching
b06.04	Third Latest Fault Type		Read Only	E000~E022 Refers to chapter 9.
b06.05	Second Latest Fault Type			
b06.06	Latest Fault Type			
b06.07	Parameters Storage Condition	0~2	0	0:Power-off Storage 1:Power-off default storage 2:Invalid
b06.08	Accumulated Running Time	0~65535h	Read Only	Display Accumulated Running Time
b06.09	Set the Password of br00.00	0~65535	65535	Password set prevent user from modifying the parameters randomly, avoiding running abnormally and damages.
Br07 Group Application Function				
b07.00	Day-part Function Selection	0~3	0	0:invalid 1:day-part A 2:day-part A and B 3:day-part A, B, C
b07.01	Day-part A Starting Time	00.00~24.00	0	<ul style="list-style-type: none"> ●Setting Starting Time and Finishing Time to 0 is invalid. ●Pressure Setting determines the steady state value of outlet pressure.
b07.02	Day-part A Pressure Setting	0.0~20.0bar	3.0bar	
b07.03	Day-part A Finishing Time	00.00~24.00	0	
b07.04	AI2 Lower Limit of Day-part A	0.0~20bar	2.0bar	
b07.05	Day-part B Starting Time	00.00~24.00	0	<ul style="list-style-type: none"> ●Once actual pressure from inlet pipe network lower than inlet pressure lower limit, the pump stops. ●When regardless of the inlet water pressure, just set the lower limit as 0.
b07.06	Day-part B Pressure Setting	0.0~20bar	3.0bar	
b07.07	Day-part B Finishing Time	00.00~24.00	0	
b07.08	AI2 Lower Limit of Day-part B	0.0~20.0bar	3.0bar	

Function Code	Name	Setting Range	Factory Setting	Description
b07.09	Day-part C Starting Time	00.00~24.00	0	
b07.10	Day-part C Pressure Setting	0.0~20.0bar	3.0bar	
b07.11	Day-part C Finishing Time	00.00~24.00	0	
b07.12	AI2 Lower Limit of Day-part C	0.0~20.0bar	2.0bar	
b07.13	Lower Limit of Inlet Pressure	0.0~100.0bar	0.0bar	Valid all day, especially for the use of taking account of inlet water pressure. When not needed,, set as 0.
b07.14	Restore Defaults	0~2	0	0:No action 1:Set to default 2:Clear error records
b07.15	Password of Group br08	0~65535	65535	
Br08 Group Application Function				
b08.00	G/P Option	0~1	1	0:G model 1:P model
b08.01	Motor Rated Power	0.4~350kw	Model Set	Depend on Model, Setting parameters according to nameplate of Motor
b08.02	Motor Rated Frequency	0.00~600.00Hz	50.00Hz	
b08.03	Motor Rated Speed	0~36000RPM	Model Set	
b08.04	Motor Rated Voltage	0~460V		
b08.05	Motor Rated Current	0.0~2000.0A		
b08.06	Set the Password of br07	0~65535	65535	Modify password of BR7.13
b08.07	Password of Factory Parameters	0~65535	xxxxxx	Don't try to enter or will cause abnormal operation and damages.

In order to ensure the pumps running safety, please enter rated value correctly from Motor Nameplate.

7. APPLICATION GUIDANCE

B603 product has various function, the following introduce some typical application cases of B603 and relevant parameter setting methods. In practical applications, you can reference to set.

7.1 Single Pump Water Supply and Parameter Setting

7.1.1 System Wiring

In Diagram : ① B603 Intelligent Controller; ② Pumps Group; ③ Pressure Tank; ④ None-return Valve; ⑤ Pressure Transducer; ⑥ Level Switch (to pool); ⑦ Fault Indicator;

⑧ Power Supply Indicator; ⑨ Fuse; ⑩ Breaker.

Only wants the faults and running indication will requires ⑦⑧⑨.

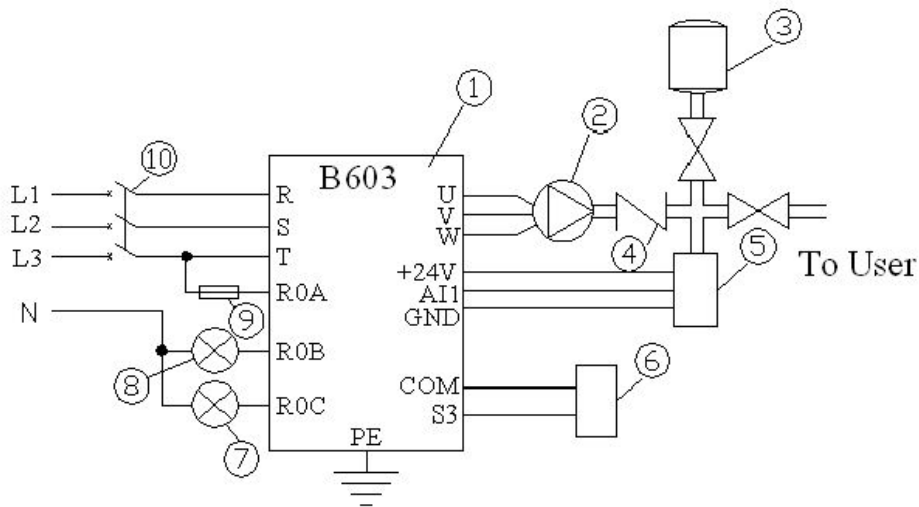

Figure7-1-1 Single Pump Wiring Addition Failure Indication

- 1) In the figure, we adopted the transducer is two line current type transducer of the company. Others connect refers to Figure4-1-1;
- 2) The pool water should be used water level control switch. If the water pump is the pipeline booster pressure pump, it does not need the water level control switch.

7.1.2 Debugging

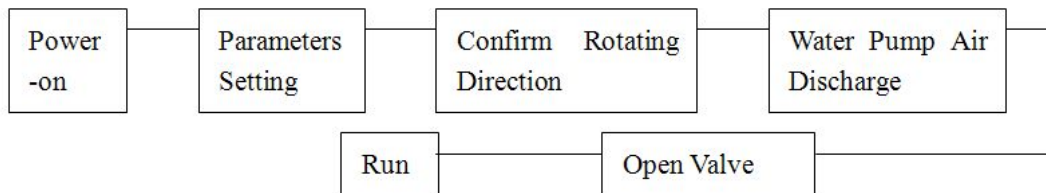

Figure7-1-2 Debugging Flow Diagram

7.1.3 Parameter Setting of Single Pump Constant Pressure control Water Supply

Code	Factory Setting	Recom -mend	Description
b00.00	65535	65535	Password of entering parameter groups. Factory set is 65535, it can be modified by b06.09
b08.01~b08.05			Ensure normal operation, must input parameter according to Nameplate of Motor
b00.02	0	x	Motor rotating direction, set according to the actual motor wiring of spot. Make sure the motor is running in forward direction
B01.05	10.0	xx.x	Transducer Range, input the max. range of connected transducer
b01.08			When display smaller than gauge, decrease b01.08; When display greater than gauge, increase b01.08

Below need to set based on working conditioning and user's requirement.

Code	Factory Setting	Recom -mend	Description
b00.01	3.0	x.x	The pressure of water supply
b01.00	8.0	xx.x	High Water Pressure Alarm Value, Prevent system from damage caused by high water pressure.
b01.01	0.5	x.x	Low Water Pressure Alarm Value, prevent pump from damage caused by anhydrous idling.
b01.16	0	x	Restart after Power-on, Considering unattended management, set parameter to 1
b05.00	0	x	Water Level Switch type, according to the using switch type 1: NC valid 2: NO valid
b05.02	2	3	*Notice: Only set this parameter on apply the terminal control , simply set the master
b00.03	0	1	* Anti-freezing function, valid it when the pump work under a freezing temperature
b02.03 b02.04			PID Parameter Debugging. Increase voltage stabilization accuracy or proper regulation when Bias oversize and overwhelmed.
br07 group			Day-part water supply, set when needs the function. Reserved as Additive Pipe Water Supply Mode, offering Day-part Variable Pressure Water Supply and prevent insufficient net work pressure from affecting Public Water Supply. Its' setting refer to section 7.3.

7.2 Multi-pump Control

7.2.1 Typical System Wiring

In diagram: UF-B603 Controller; QA-Automatic Air Switch; QF-Break; FU—Fuse; HB—Power Light; HC—Fault Light; MP—Motor and Pump; BQ—Water Level Switch; BP1—Outlet Transducer; BP2—Backup Transducer.

Only wants the faults and running indication will requires the HB,HC,FU.

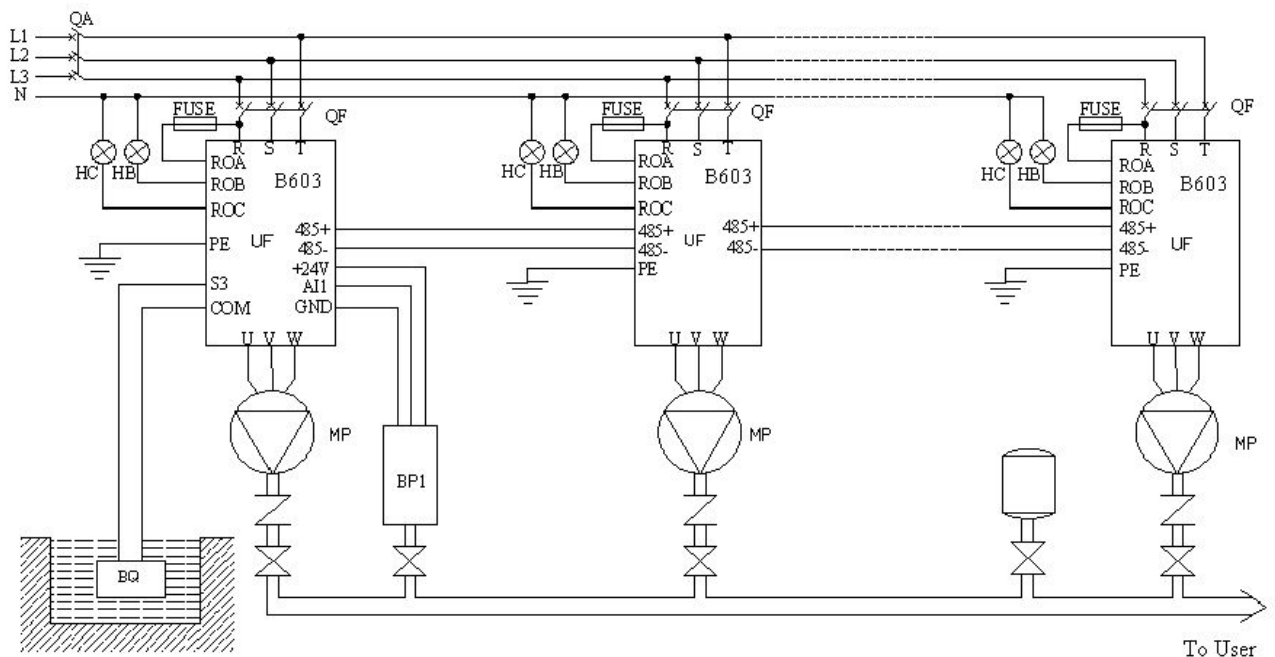

Figure7-2- 1 Multi-pump Control Wiring

7.2.2 Related parameter setting

Table 7-2-1 Multi-pump control master setting

Code	Factory setting	recom-mend	Description
b00.00	65535	65535	Password of entering parameter groups. Factory set is 65535, it can be modified by b06.09
b08.01~ b08.05			Motor parameter, must input parameter according to Nameplate of Motor
b00.02	0	x	Motor rotating direction, set according to the actual motor wiring of spot. Make sure the motor is running in forward direction
b03.00	02	00	Communication address, the master should be 00
b03.08	00	N	Auxiliary number, assume 1 master N auxiliaries, set as N.
b01.05	10.0	xx.x	Transducer Range, input the max. range of connected transducer
b01.08	5.00	x.xx	When display smaller than gauge, decrease b01.08; When display bigger than gauge, increase b01.08
Below need to set based on working conditioning and user's requirement.			
b00.01	3.0	x.x	The Pressure of water supply
b01.00	8.0	xx.x	High Water Pressure Alarm Value, Prevent system from damage caused by high water pressure.
b01.01	0.5	x.x	Low Water Pressure Alarm Value, prevent pump from damage caused by anhydrous idling.
b01.16	0	x	Restart after Power-on, Considering unattended management, set parameter to 1
b01.17	1	x	Running mode select, 0 is synchronous control mode, 1 is master-slave control mode
b05.00	2	x	Water Level Switch type, according to the using switch type 1: NC valid 2: NO valid
b05.10	8.00	xx.x	Alternating time, balance the service time of all pumps.
br07 group			Day-part water supply, set when needs the function. Reserved as Additive Pipe Water Supply Mode, offering Day-part Variable Pressure Water Supply and prevent insufficient net work pressure from affecting Public Water Supply. Its' setting refer to section 7.3.
b00.03	0	1	Anti-freezing function , valid it when the pump work under a freezing temperature
b03.09	2	0	Set this parameter when enable fault shift function.

Table 7-2-2 Multi-pump control auxiliaries' setting

Code	Factory setting	Recom-mend	Description
b00.00	65535	65535	Password of entering parameter groups. Factory set is 65535, it can be modified by b06.09

Code	Factory setting	Recom mend	Description
b02.08	1.0	0.0	Auxiliary is need not to connect a transducer, this parameter should be set as 0.If you use the Fault Shift, this parameter of the backup master no need to modify.
b08.01~ b08.05			Motor parameter, must input parameter according to Nameplate of Motor
b00.02	0	x	Motor rotating direction, set according to the actual motor wiring of spot. Make sure the motor is running in forward direction
b03.00	02	01~N	Communication address, the auxiliaries should be set as 01 to N in order.
b03.08	00	N	Auxiliary number, assume 1 master N auxiliaries, set as N.
b03.09	2	1	Only Set the Auxiliary which address parameter b03.00 is equal to "01"when enable the Fault Shift , others no need to modify

7.3 Day-Part Water Supply Application Setting

7.3.1 System Wiring

In diagram: ①B603controller ②Pumps ③Air Pressure Tank
 ④Water Inlet Transducer ⑤Water Outlet Transducer
 ⑥Level Control Switch (Use in no negative pressure water supply)

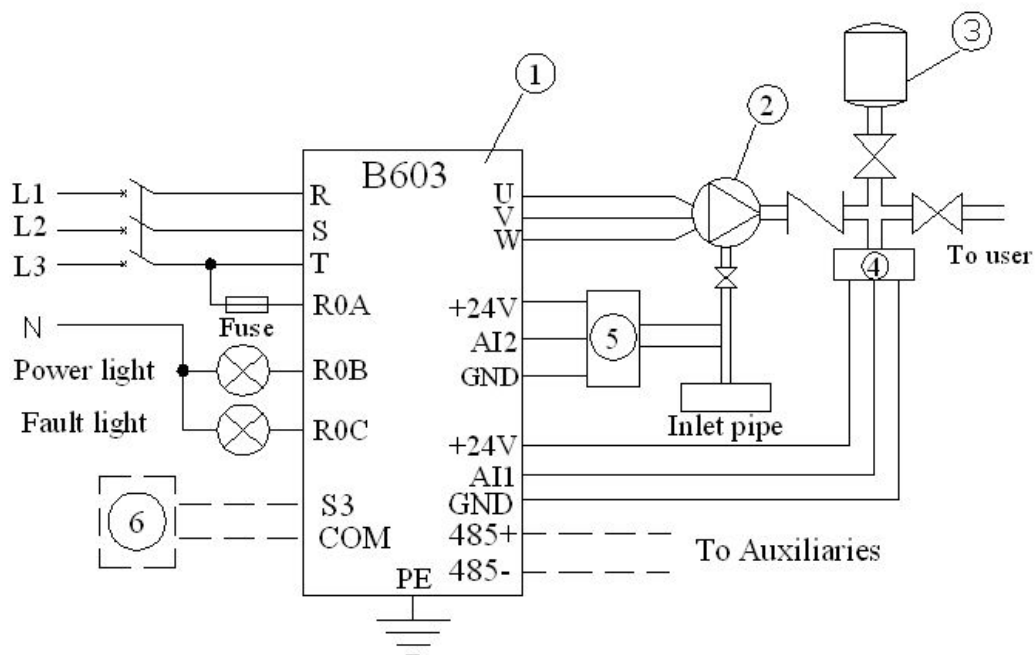

Figure7-3- 1 Day-part water supply wiring

7.3.2 Typical Application

Use in pipe pressure lamination, no negative pressure water supply, pipe network add-pressure to up level tank water supply, etc.

For example:

first part running 2.5bar from 00:00 to 06:00, stop running as water inlet pressure below 2.0bar;

Second part running 3.2bar from 06:00 to 13:30, stop running when inlet pressure below 2.3bar;

Third part running 3.5bar from 17:00 to 23:00, stop running when inlet pressure below 2.2bar;

The undefined day part running 3.0bar, stop running when inlet pressure below 1.8bar.

7.3.3 Parameter Settings

Follow section 7.1 or section 7.2 to set other parameters first, and then refer to this application to set day-part control parameters.

Table7-3-1 Day-part water supply parameter setting

Code	Factory Setting	Recom mend	Description
b01.11 b01.13			Inlet transducer calibration(b01.11,b01.13), if needn't detect inlet pressure, no need to install inlet transducer and calibration, but the inlet pressure lower limit of every day-part set as 0 is needed.
b07.00	0	3	Day-part number setting, 0 means day-part control invalid, we now choose 3 day-part.
b07.01	00.00	00.00	Set 00:00~06:00 running with 2.5bar, stop when inlet pressure below 2.0bar. (It recovers running when inlet pressure return to 2.0bar again)
b07.02	3.0	2.5	
b07.03	00.00	06.00	
b07.04	2.0	2.0	
b07.05	00.00	06.00	Set 06:00~13:30 running with 3.2bar, stop when inlet pressure below 2.3bar.
b07.06	3.0	3.2	
b07.07	00.00	13.50	
b07.08	2.0	2.3	
b07.09	00.00	17.00	Set 17:00~23:00 running with 3.5bar, stop when inlet pressure below 2.2bar.
b07.10	3.0	3.5	
b07.11	00.00	23.00	
b07.12	2.0	2.2	
b07.13	0.0	1.8	Set running with 3.0bar at the undefined time, stop when inlet pressure below 1.8bar.
b00.01	3.0	3.0	

7.4 Terminal Run/Stop Control Wiring and Setting

7.4.1 System Wiring

Base on above applications, connect a switch to **S1-COM** refers to section 4.4.2.

In diagram: ① B603 intelligent controller; ② Pumps; ③ Air Pressure Tank; ④ Outlet Transducer; ⑤ Inlet Transducer; ⑥ Water Level Switch; ⑦ External Run/Stop Switch.

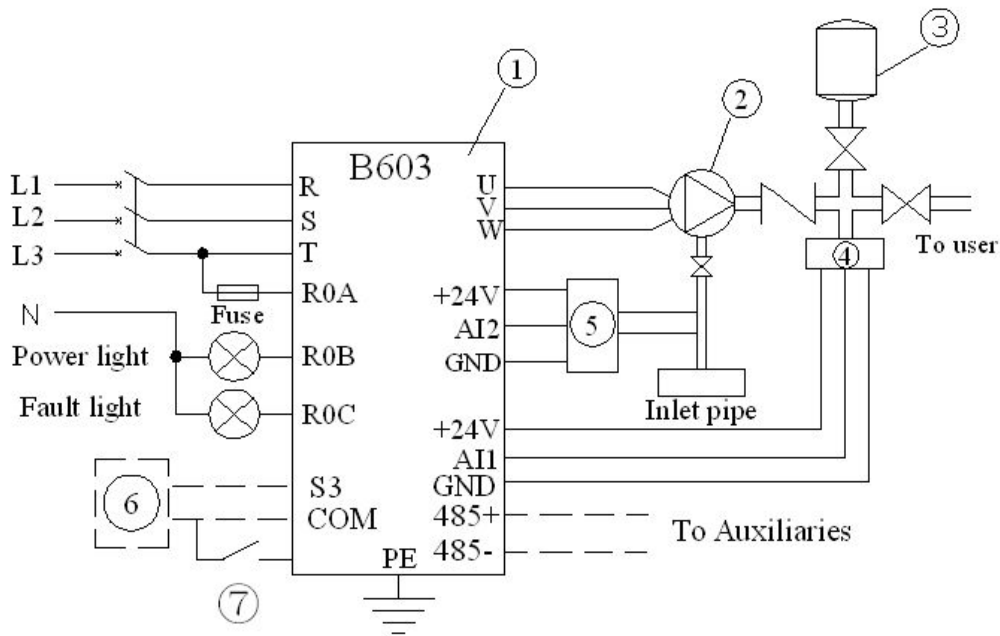

Figure 7-4-1 Terminal Run/Stop Wiring

7.4.2 Operation

Widely use in the occasion of remote run/stop, it's recommended to use a shield twisted pair to wire the external switch. When the external switch of **S1-COM** turn on, pumps running, when it turn off, pumps stop.

7.4.3 Settings

According to the application and section 7.1 or section 7.2 to set other parameters first, and then set master b05.02=3. Auxiliaries should press run to put it on standby after set it's parameters.

7.5 Manual/Auto Control Wiring and Setting

7.5.1 System Wiring

Base on above applications, connect a switch to **S2-COM** refers to Figure4-1-1. Normally apply this function on auxiliaries.

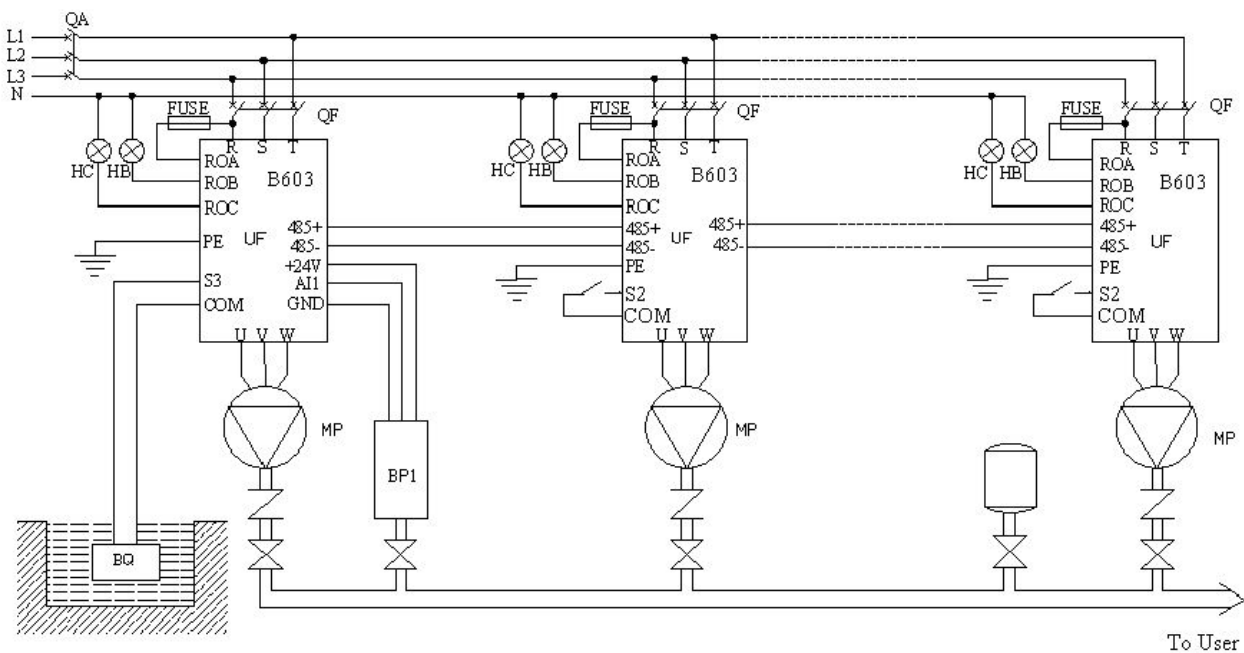

Figure 7-5-1 Manual/Auto control wiring

7.5.2 Operations

Widely use in building site manual control water supply, new pipe system quick fill etc. needs full-frequency running place. When finish the parameter set, switch on **S2-COM**, the switch pump running with full-frequency.

7.5.3 Settings

According to the application and section 7.1 or section 7.2 to set other parameters first, and then set auxiliaries b05.02=2.

7.6 Electric Contact Gauge Water Supply

7.6.1 System Wiring

In diagram: ① B603 intelligent controller; ② Pumps; ③ Air Pressure Tank; ④ Pressure Switch; ⑤ Water Level Switch

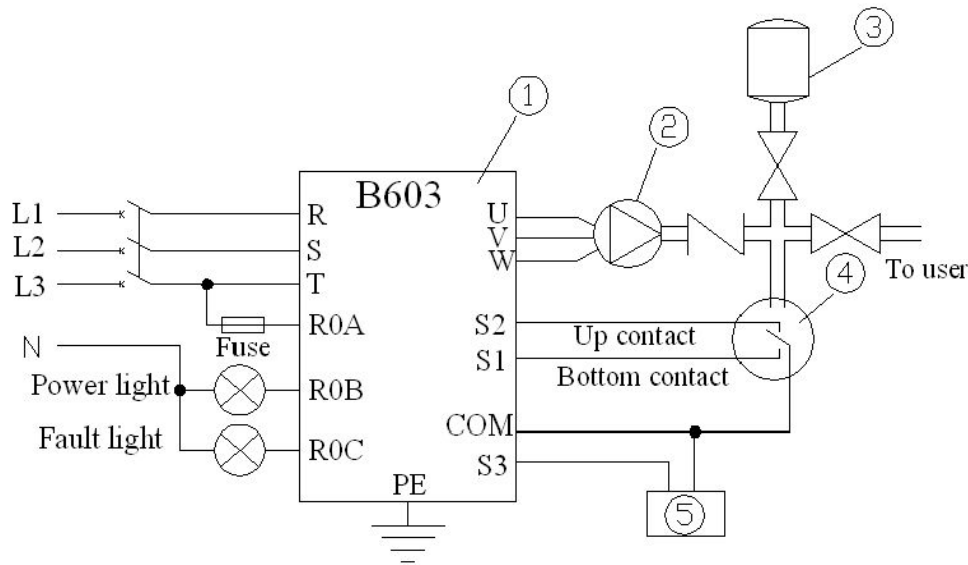

Figure7-6- 1 Electric Contact Pressure Gauge Control Wiring diagram

7.6.2 Electric Contact Pressure Gauge Adjust

This example use the Electric Contact Pressure Gauge instead of the transducer (Wiring refer to figure 4-1-1), adjust the gauge's up electric contact and bottom electric contact to the range of need is should be done before running. For example, want a 0.3MPa water supply, then up contact adjust above scale 0.3MPa (such as at 0.32MPa), bottom electric contact below 0.3MPa (such as at 0.28MPa).

7.6.3 Function Settings

Table 7-6- 1 Electric Contact Pressure Gauge Control Setting

Code	Factory Setting	Recom mend	Description
b00.00	65535	65535	Password of entering parameter groups. Factory set is 65535, it can be modified by b06.09
b02.08	1.0%	0.0%	All Feedback Lost Detecting Value, this application need not pressure detect, set the parameter 0
b08.01~ b08.05			Ensure normal operation, must input parameter according to Nameplate of Motor
b00.02	0	x	Motor rotating direction, set according to the actual motor wiring of spot. Make sure the motor is running in forward direction

Code	Factory Setting	Recom mend	Description
b01.02	20	xx	Low Pressure Running Time, Should be increase at the occasion of water pressure rise slowly. The LP Running Time stand for the maximum switch on duration time of the bottom electric contact. When it run for three time of b01.02, the bottom contact (namely S1 - COM) still switch on, the controller break down and display LP.
b05.02	2	1	Terminal S1S2 control, set as electric contact pressure gauge control
Below need to set based on working conditioning and user's requirement.			
b01.16	0	x	Restart after Power-on, Considering unattended management, set parameter to 1
b05.00	2	x	Water Level(Terminal S3) Switch type, according to the using switch type 1: NC valid 2: NO valid
b05.01	001	xxx	S3 Action Delay Time, In case slow incoming water leads to frequent initiate-stop.
b05.03 b05.04			Acc. and Dec. Time. It is recommended to set equal or above 20S, a short acc./dec. time lead to a fluctuate control.

7.7 Pumping Application

7.7.1 System Wiring

In diagram: ①B603 controller ②Pumps ③Water level transmitter

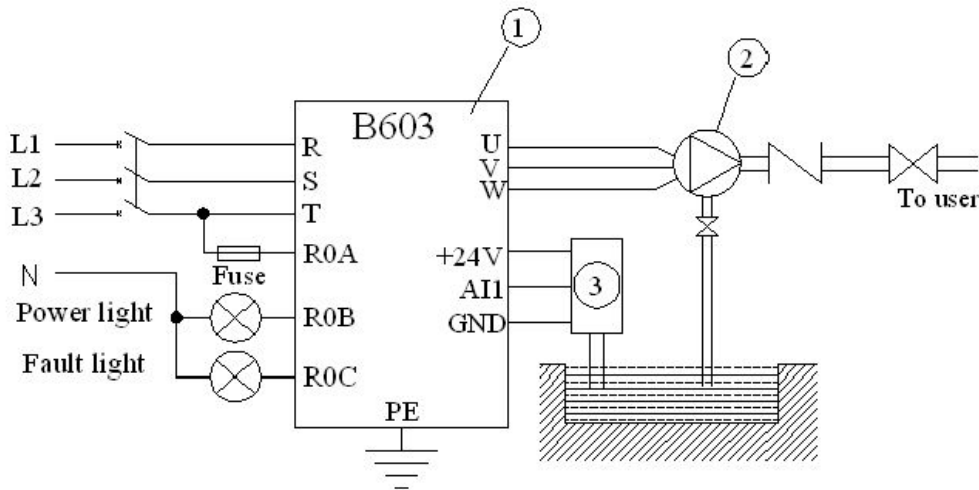

Figure7-7-1 Pumping control wiring

7.7.2 Example

Extensive used in environmentally friendly sewage treatment, water lever control, drainage and irrigation, etc. Water level above 40%, Pumping in full-frequency,; Below 40%,slow pumping; Below 10%, stop pumping.

7.7.3 Relating Parameter Setting

Table 7-7- 1 Pumping control application setting

Code	Factory Setting	Recommended	Description
b00.00	65535	65535	Password of entering parameter groups. Factory set is 65535, it can be modified by b06.09
b08.01~ b08.05			Ensure normal operation, must input parameter according to Nameplate of Motor
b00.02	0	x	Motor rotating direction, set according to the actual motor wiring of spot. Make sure the motor is running in forward direction
b02.02	0	1	PID Output Characteristics, set as pumping characteristics
b01.05	10.0	100.0	Set as the range of water level transmitter
b01.00	8.0	100.0	High Water Pressure/Level Alarm Value, set as the alarm water level.
b01.01	0.5	10.0	Low Water Pressure/Level Alarm Value, water level below this value stop pumping
b00.01	3.0	40.0	The Full-frequency pumping water level, above this value full-frequency pumping, below b00.01 and above b01.01 pumping with the setting frequency of b05.07.
Below need to set based on working conditioning and user's requirement.			
b01.06 b01.08			Water level transmitter calibration, b01.06 use to adjust transducer zero bias. b01.08 use to accordant the display pressure and the transducer pressure. When display smaller than gauge, decrease b01.08; When display bigger than gauge, increase b01.08
b01.02	20	xx	Low Pressure Running Time, set according to actual condition, determine LP detect running time, keep the factory set is ok.
b05.09	10	30	Low Water Level Restart Delay Time, restart with the value setting after a LP delay. Manual restart after low water level need not to change this parameter.

7.8 Application Summary

B603 intelligent water supply controller owns powerful function, to be intelligent water supply, beside previous typical applications, it covers most applications. Such as air conditioning cold water pump, cooling pump constant temperature automatic control, hot water circulation system(include solar energy, heat pump water supply etc.), water treatment system, garden landscape, industry and agriculture production water supply system. User is urged according to spot condition and various functions of B603 to fulfill a good performance water supply.

B603 intelligent constant water supply controller haven't special demands to peripherals, it almost can be use the normal component. Such as water detection use transducer, transmitter (include water level transmitter, temperature transmitter, etc.) or inductive remote transmission pressure gauge, its output is 4~20mA, 0~5V_{DC} and 0~10 V_{DC} Standard signal. For a easy control, use an electric contact pressure gauge or pressure switch can be achieved; Water level switch can use the float switch or pressure switch and so on general application device. All of this allows user according to the work condition select appropriate peripheral device.

8. FAULT AND TROUBLE SHOOTING

8.1 System Running Fault and Trouble Shooting

Abnormal Function	Reason	Solution
Can't Sleep	1、Outlet Pipe Leakage; 2、Check Valve Leakage; 3、Pressure Tank Damage; 4、High Environment EMI; 5、Wrong Parameter	<ul style="list-style-type: none"> • Check Outlet Pipe, or to set b04.04; • Inspect Check Valve; • Change Pressure Tank; • Transducer adopt shielded wires, Shielded layer connect to PE; • Ensure b04.00=1
Display Pressure Error	1、Detector Error; 2、Wrong Parameters; 3、Transducer Wires is too long;	<ul style="list-style-type: none"> • Adopt Standard Detector; • Calibration parameter b01.05, b01.08; • Avoid Use too Long Transducer Wires;
Full-Frequency running	1、Lose Pressure Feedback; 2、Wrong Parameter; 3、Pump Under power;	<ul style="list-style-type: none"> • Check Transducer and Wires; • b05.02 should not be set as 1; • S2-Com should be open; • Set b07.14=1, take a factory reset
Pressure vibration, stabilize slow	1、PID Value unmatched; 2、Acc./Dec. Time too fast; 3、Big delay on pressure feedback.	<ul style="list-style-type: none"> • Tune PI value b02.03、b02.04 • Tune Acc./Dec. time b05.03、b05.04 • Avoid Use too Long Transducer Wires
Motor Noise	1、Motor Abnormal; 2、Motor installation is not stable; 3、Low Carry-Frequency	<ul style="list-style-type: none"> • Check Motor; • Proper turn up Carrier Frequency b05.08

8.2 Water supply Running Fault and Trouble Shooting

Fault Code	Fault Type	Reason	Solution
LP	Low water pressure	Sufficient water inflow; Motor rotates in the reverse direction	<ul style="list-style-type: none"> • Check the installation of pressure transmitter • Check the motor's direction of rotation is correct or not • Check the parameter b01.01(setting value too big) • Check the system
HP	High water pressure	The parameter b01.00 setting value is too small	<ul style="list-style-type: none"> • Check the installation of pressure transmitter • Check the parameter b01.00 (setting value too small) • Check the system
LL	Low water level	Water level of pool is too low	<ul style="list-style-type: none"> • Check the water system • Check the situation of the control terminal S1
E022	Sensor fault	Pressure transmitter disconnected; Pressure transmitter short circuit; PID feedback disappears	<ul style="list-style-type: none"> • Check the cable between pressure transmitter and controller; • Check the pressure transmitter • Check PID feedback source

8.3 Controller Running Fault and Trouble Shooting

Fault Code	Fault Type	Reason	Solution
E001	IGBT ph-U fault (OUT1)	Acc/Dec time is too short; IGBT module fault; Malfunction caused by interference; Grounding is not properly	<ol style="list-style-type: none"> 1. Increase Acc/Dec time; 2. Check external equipments and eliminate interference; 3. Ask supplier for support
E002	IGBT ph-V fault (OUT2)		
E003	IGBT ph-W fault (OUT3)		
E004	Over-current when acceleration (OC1)	Acc time is too short; Load is too heavy; Low input voltage; The capacity of controller is small	<ol style="list-style-type: none"> 1. Increase Acc time; 2. Check the power supply; 3. Select bigger capacity controller
E005	Over-current when deceleration (OC2)	Dec time is too short; Load is too heavy; The capacity of controller is small	<ol style="list-style-type: none"> 1. Increase Dec time; 2. Increase braking unit; 3. Select bigger capacity controller
E006	Over-current when constant speed running (OC3)	Sudden change of load; Low input voltage; The capacity of controller is small	<ol style="list-style-type: none"> 1. Check the load; 2. Check the power supply; 3. Select bigger capacity controller

Fault Code	Fault Type	Reason	Solution
E007	Over-voltage when acceleration (OV1)	High input voltage; Regenerative energy from the motor is too large	1. Check the power supply; 2. Avoid to restart the motor until it stop running completely
E008	Over-voltage when deceleration (OV2)	High input voltage; Deceleration time is too short; Load is too heavy	1. Increase Dec time; 2. Check the power supply; 3. Increase braking unit
E009	Over-voltage when constant speed running (OV3)	High input voltage; Load is too heavy	1. Install input reactor; 2. Increase braking unit
E010	DC bus under-voltage (UV)	Low input voltage	Check the grid's input power supply
E011	Motor overload (OL1)	Low input voltage; Improper overload protection threshold of motor; Sudden change of load; The capacity of motor is too small	1. Check the power supply; 2. Set the rated current of motor properly; 3. Check the load, adjust the value of torque boost; 4. Select proper capacity motor
E012	Controller overload (OL2)	Acc time is too short; Restart the motor when it is decelerating; Low input voltage; Load is too heavy	1. Increase Acc time; 2. Avoid to restart the motor until it stop running completely; 3. Check the power supply; 4. Select bigger capacity controller
E013	Input phase failure (SPI)	Open-phase occurred in power supply	Check the wiring, installation and the power supply
E014	Output phase failure (SPO)	Open-phase occurred at output side of main circuit	Check the wiring, installation and motor

Fault Code	Fault Type	Reason	Solution
E015	Rectify overheat (OH1)	Sudden over-current; Input/output side has short circuit; Cooling fans of controller stopped or damaged; Obstruction of ventilation channel; Ambient temperature is too high; Carrier frequency is too high; Near heat source; Wires or connectors of control board are loose;	<ol style="list-style-type: none"> 1. Refer to measures of over-current 2. Check the wiring 3. Replace cooling fans; 4. Clear the ventilation channel; 5. Install cooling unit; 6. Decrease carrier frequency; 7. Remove the heat source; 8. Check the wires and connectors; 9. Ask supplier for support;
E016	IGBT overheat (OH2)	Auxiliary power supply unit is damaged or low driving voltage for IGBT; Power module bridge is damaged; Control board is abnormal	
E018	Communication fault	Improper baud rate setting; Communication is interrupted for a long time; Receive wrong data	<ol style="list-style-type: none"> 1. Check communication devices and signals 2. Set proper baud rate 3. Press STOP/RST to reset, then ask for service
E019	Current detection fault (ITE)	Wires or connectors of control board are loose; Auxiliary power supply unit is damaged; Current detector is damaged or amplifying circuit is abnormal	<ol style="list-style-type: none"> 1. Check the wiring and connectors 2. Ask supplier for support
E021	EEPROM fault(EEP)	R/W fault of control parameters	<ol style="list-style-type: none"> 1. Press STOP/RST to reset 2. Ask for support

9. MAINTENANCE

! WARNING	
<ul style="list-style-type: none"> • Maintenance must be performed according to designated maintenance methods; • Maintenance must be performed by authorized personnel only; • After turning off the main circuit power supply, please wait for 10 minutes before maintenance; • DO NOT directly touch components or devices of PCB board. Otherwise the controller can be damaged by static electricity; • After maintenance, all screws must be tightened. 	

9.1 Daily Maintenance

In order to prevent the fault and prolong the service life of the controller, user shall daily inspect the controller. The following table indicates the inspection content:

Items to be checked	Means/Methods
Temperature/Humidity	Ambient temperature range shall be 0~40°C, humidity range shall be 20~90%
Oil fog/Dust/Vapor	Ensure there isn't oil fog, dusty and vapor accumulation
Controller	Ensure there isn't abnormal vibration, abnormal heat, abnormal noise and abnormal smell
Fans	Ensure fans are working at good condition, speed and air flow are normal
Power supply	Ensure both the voltage and frequency of power supply are in allowing range
Motor	Ensure there isn't abnormal vibration, abnormal noise, abnormal heat and open-phase problems

9.2 Periodic Maintenance

In order to prevent the fault of controller to make it operate smoothly in high-performance for a long time, user must inspect the controller periodically (within half year). The following table indicates the inspection content:

Items to be checked	Inspection content	Means/Methods
Screws	Check whether the screws of control terminals are loose	Tighten them with screwdriver
PCB boards	Dusty, dirt	Clean them with vacuum cleaner
Fans	Abnormal noise, vibration; check whether the fans are used up to 20,000 hours	<ol style="list-style-type: none"> 1. Clean the air ducts with vacuum cleaner; 2. Replace the fans
Electrolytic capacitors	Abnormal color and abnormal smell	Replace the electrolytic capacitors
Cooling plate	Dusty, dirt	Clean them with vacuum cleaner
Power components	Dusty, dirt	

Items to be checked	Inspection content	Means/Methods
Pump unit	Dusty, sundries; whether the pumps are stuck or running into problems.	<ol style="list-style-type: none"> 1. Clean them with vacuum cleaner; 2. Replace the pump unit

9.3 Replacement of Wearing parts

Fans and electrolytic capacitors are wearing parts; please make periodic replacement to ensure long term, safety and failure-free operation. The replacement periods are as follows:

- Fan: must be replaced when using up to 20,000 hours;
- Electrolytic capacitor: must be replaced when using up to 30,000~40,000 hours.

10. EPILOGUE

The manual provide user spot installing and debugging, for convenient of maintenance and technical personnel spot debugging consult, please keep it carefully after use.

 Prohibit Installation and debugging Parameter being modified by irrelevant personnel, Parameters randomly modified will induce abnormal operation and damaging intelligent controller as well as water supply system, even cause personal injury and safe accidents.

 Please ensure the correct rotating direction which was indicated at the backend of the motor before using. It will cause the situation such as insufficient power, insufficient supply pressure, vibration, noise and so no when the motor is running in the opposite rotating direction.

Agent: