

## Green-Mode PWM Controller with High-Voltage Start-Up Circuit

Rev. 00

### General Description

The LD7575B is a current-mode PWM controller with excellent power-saving operation. It features a high-voltage current source to directly supply the startup current from bulk capacitor and further to provide a lossless startup circuit. The integrated functions such as the leading-edge blanking of the current sensing, internal slope compensation, and the small package provide the users a high efficiency, minimum external component counts, and low cost solution for AC/DC power applications.

Furthermore, the embedded over voltage protection, over load protection and the special green-mode control provide the solution for users to design a high performance power circuit easily. The LD7575B is offered in both SOP-8 and DIP-8 package.

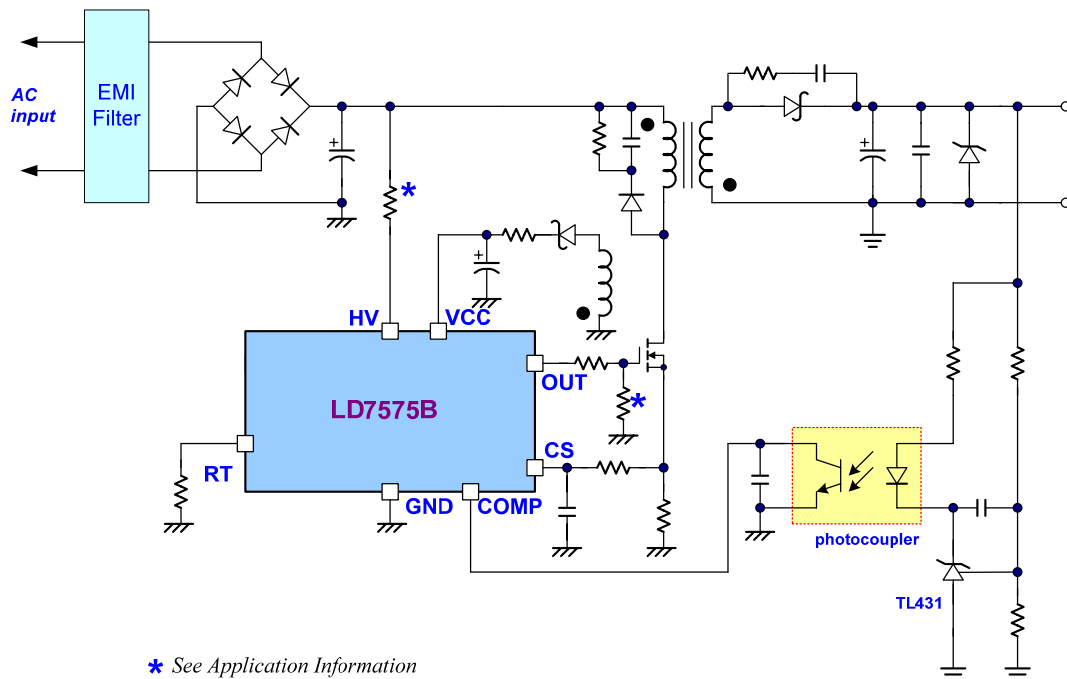
### Features

- High-Voltage (500V) Startup Circuit
- Current Mode Control
- Non-Audible-Noise Green Mode Control
- UVLO (Under Voltage Lockout)
- LEB (Leading-Edge Blanking) on CS Pin
- Programmable Switching Frequency
- Internal Slope Compensation
- OVP (Over Voltage Protection) on Vcc
- OLP (Over Load Protection)
- 500mA Driving Capability

### Applications

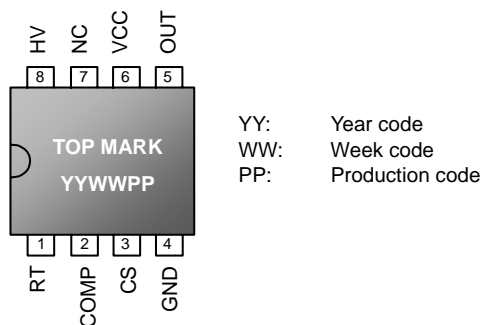
- Switching AC/DC Adapter and Battery Charger
- Open Frame Switching Power Supply
- LCD Monitor/TV Power

### Typical Application



## Pin Configuration

SOP-8 & DIP-8 (TOP VIEW)



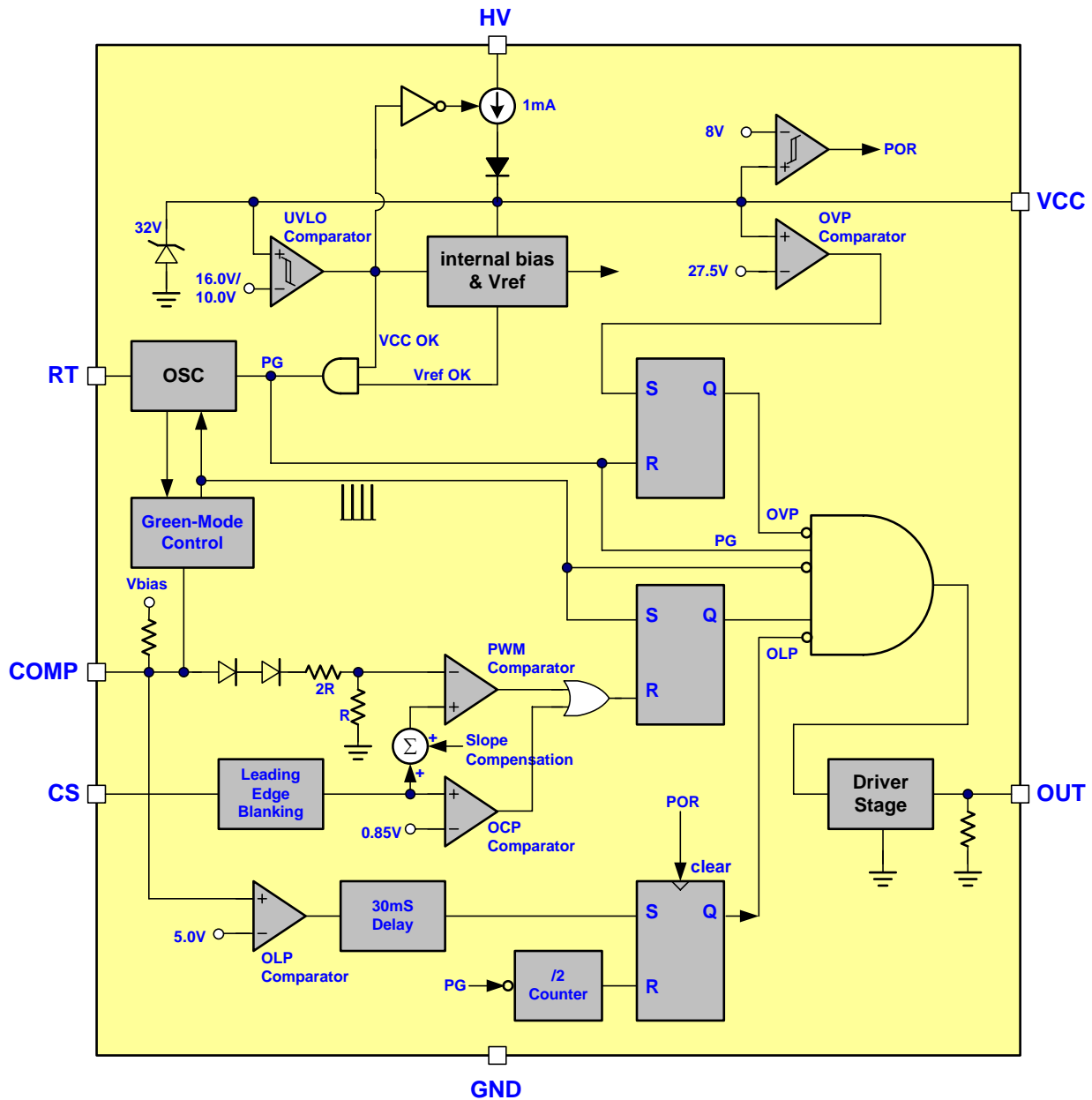
## Ordering Information

Part number	Package	Top Mark	Shipping
LD7575B GS	SOP-8 (Green PK)	LD7575BGS	2500 /tape & reel
LD7575B GN	DIP-8 (Green PK)	LD7575BGN	3600 /tube /Carton
LD7575B PS	SOP-8 (Pb Free)	LD7575BPS	2500 /tape & reel
LD7575B PN	DIP-8 (Pb Free)	LD7575BPN	3600 /tube /Carton

The LD7575B is ROHS Compliant.

## Pin Descriptions

PIN	NAME	FUNCTION
1	RT	This pin is to program the switching frequency. By connecting a resistor to ground to set the switching frequency.
2	COMP	Voltage feedback pin (same as the COMP pin in UC384X), By connecting a photo-coupler to close the control loop and achieve the regulation.
3	CS	Current sense pin, connect to sense the MOSFET current
4	GND	Ground
5	OUT	Gate drive output to drive the external MOSFET
6	VCC	Supply voltage pin
7	NC	Unconnected Pin
8	HV	Connect this pin to positive terminal of bulk capacitor to provide the startup current for the controller. When Vcc voltage trips the UVLO(on), this HV loop will be off to save the power loss on the startup circuit.

**Block Diagram**


**Absolute Maximum Ratings**

Supply Voltage VCC.....	30V
High-Voltage Pin, HV.....	-0.3V~500V
COMP, RT, CS.....	-0.3 ~7V
Junction Temperature.....	150°C
Operating Ambient Temperature.....	-20°C to 85°C
Storage Temperature Range.....	-65°C to 150°C
Package Thermal Resistance (SOP-8).....	160°C/W
Package Thermal Resistance (DIP-8).....	100°C/W
Power Dissipation (SOP-8, at Ambient Temperature = 85°C).....	400mW
Power Dissipation (DIP-8, at Ambient Temperature = 85°C).....	650mW
Lead temperature (Soldering, 10sec).....	260°C
ESD Voltage Protection, Human Body Model (except HV Pin).....	3KV
ESD Voltage Protection, Machine Model (except HV Pin).....	300V
Gate Output Current.....	500mA

**Caution:**

Stresses beyond the ratings specified in “Absolute Maximum Ratings” may cause permanent damage to the device. This is a stress only rating and operation of the device at these or any other conditions above those indicated in the operational sections of this specification is not implied.

**Recommended Operating Conditions**

Item	Min.	Max.	Unit
Supply Voltage Vcc	11	25	V
Vcc Capacitor	10	33	μF
Switching Frequency	50	130	KHz

**Electrical Characteristics**

(T<sub>A</sub> = +25°C unless otherwise stated, V<sub>CC</sub>=15.0V)

PARAMETER	CONDITIONS	MIN	TYP	MAX	UNITS
<b>High-Voltage Supply (HV Pin)</b>					
High-Voltage Current Source	V <sub>CC</sub> < UVLO(on), HV=500V	0.5	1.0	1.5	mA
Off-State Leakage Current	V <sub>CC</sub> > UVLO(off), HV=500V			35	μA
<b>Supply Voltage (Vcc Pin)</b>					
Startup Current			0.5		mA
Operating Current (with 1nF load on OUT pin)	V <sub>COMP</sub> =0V		2.4	3.4	mA
	V <sub>COMP</sub> =3V		2.9	4.4	mA
	Protection tripped (OVP)		0.5		mA
	Protection tripped (OLP)		0.43		mA
UVLO (off)		9.0	10.0	11.0	V
UVLO (on)		15.0	16.0	17.0	V
OVP Level		25.0	27.5	30.0	V
<b>Voltage Feedback (Comp Pin)</b>					
Short Circuit Current	V <sub>COMP</sub> =0V		1.5	2.2	mA
Open Loop Voltage	COMP pin open		6.3		V
Green Mode Threshold V <sub>COMP</sub>			2.35		V
<b>Current Sensing (CS Pin)</b>					
Maximum Input Voltage		0.80	0.85	0.90	V
Leading Edge Blanking Time			220		nS
Input impedance		1			MΩ
Delay to Output			100		nS
<b>Oscillator (RT pin)</b>					
Frequency	RT=100KΩ	60.0	65.0	70.0	KHz
Green Mode Frequency	F <sub>s</sub> =65.0KHz		21		KHz
Temp. Stability	(-40°C ~ 105°C)			5	%
Voltage Stability	(V <sub>CC</sub> =11V-25V)			1	%
<b>Gate Drive Output (OUT Pin)</b>					
Output Low Level	V <sub>CC</sub> =15V, I <sub>o</sub> =20mA			1	V
Output High Level	V <sub>CC</sub> =15V, I <sub>o</sub> =20mA	9			V
Rising Time	Load Capacitance=1000pF		50	160	nS
Falling Time	Load Capacitance=1000pF		30	60	nS
<b>OLP (Over Load Protection)</b>					
OLP Trip Level			5.0		V
OLP Delay Time (note)	F <sub>s</sub> =65KHz		33		mS

Note: The OLP delay time is proportional to the period of switching cycle. So that, the lower RT value will set the higher switching frequency and the shorter OLP delay time.

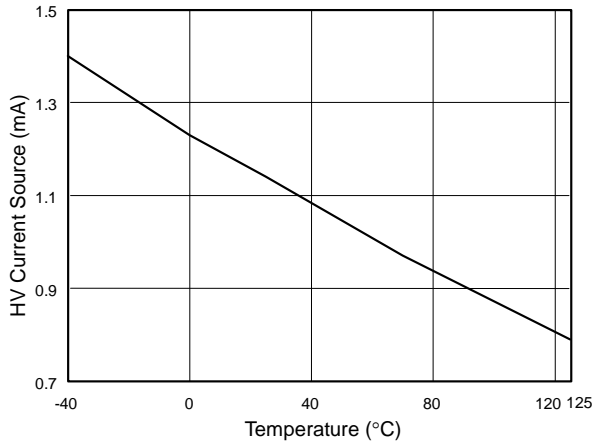
**Typical Performance Characteristics**


Fig. 1 HV Current Source vs. Temperature (HV=500V, Vcc=0V)

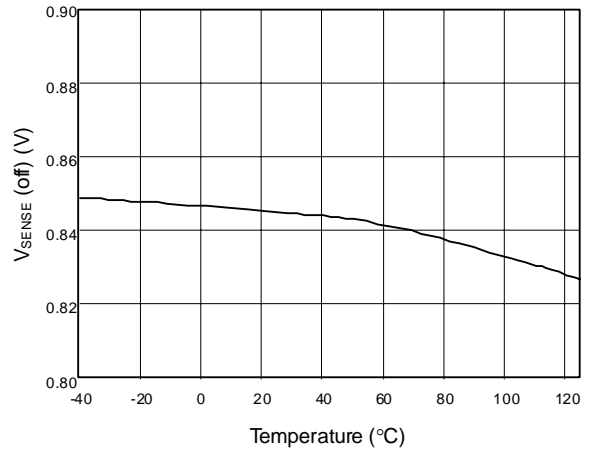
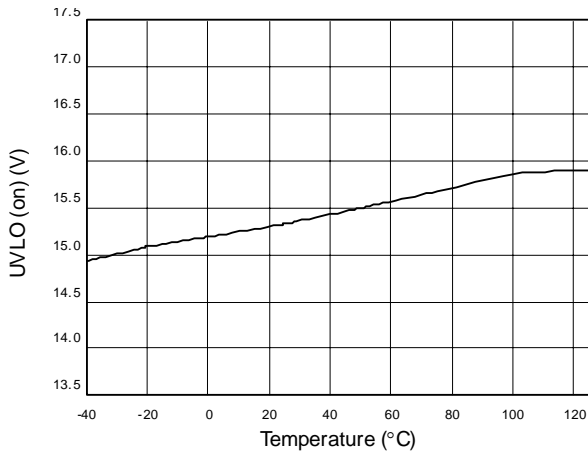

 Fig. 2 V<sub>SENSE</sub> (off) vs. Temperature


Fig. 3 UVLO (on) vs. Temperature

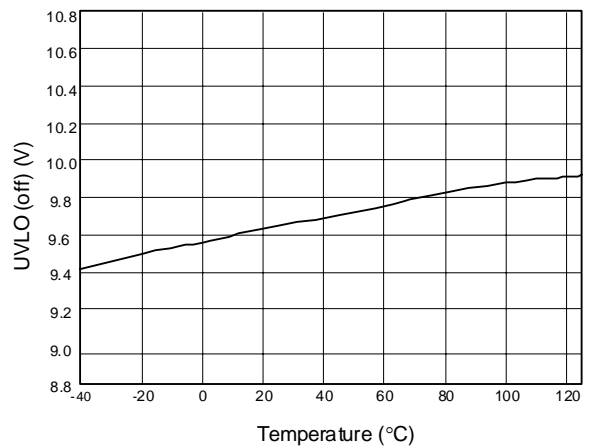


Fig. 4 UVLO (off) vs. Temperature

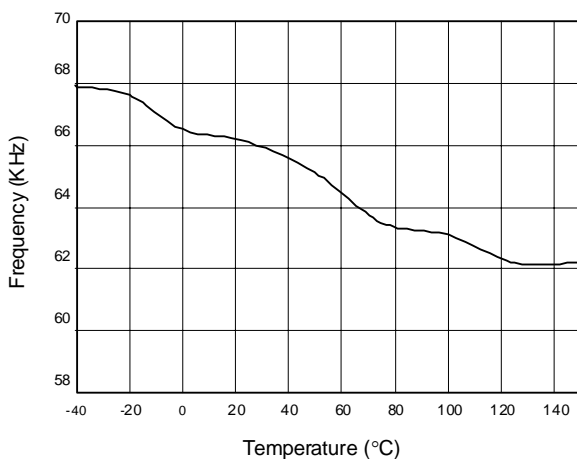


Fig. 5 Frequency vs. Temperature

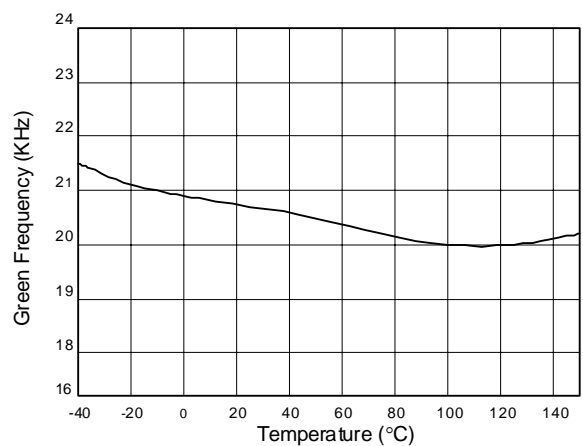


Fig. 6 Green Mode Frequency vs. Temperature

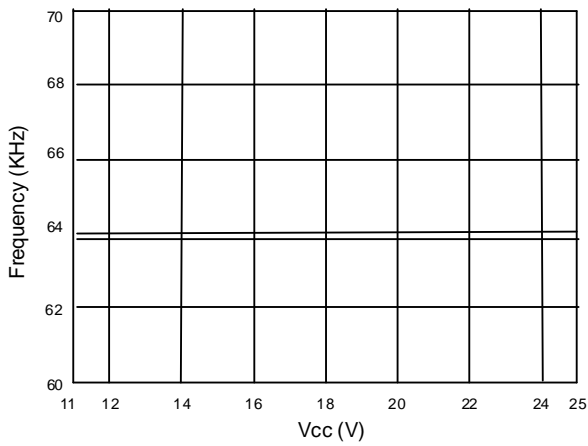


Fig. 7 Frequency vs. Vcc

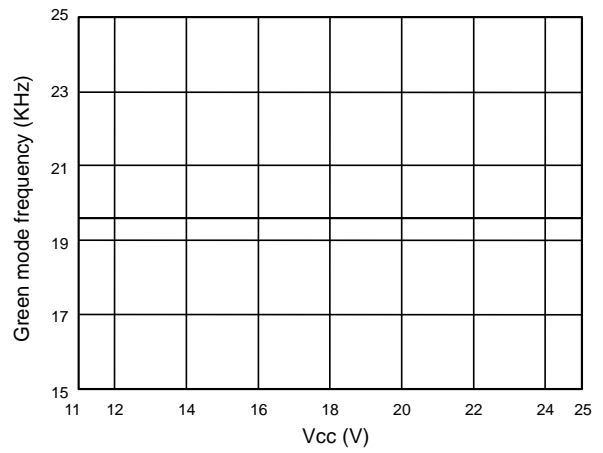


Fig. 8 Green mode frequency vs. Vcc

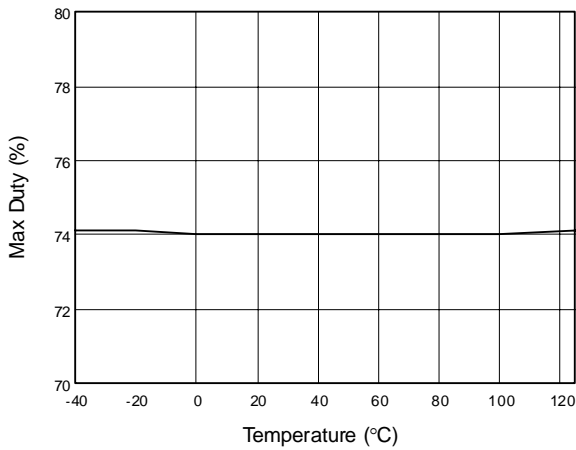


Fig. 9 Max Duty vs. Temperature

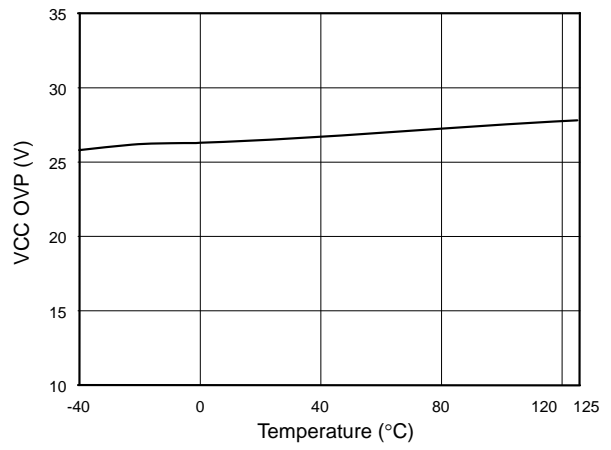


Fig. 10 VCC OVP vs. Temperature

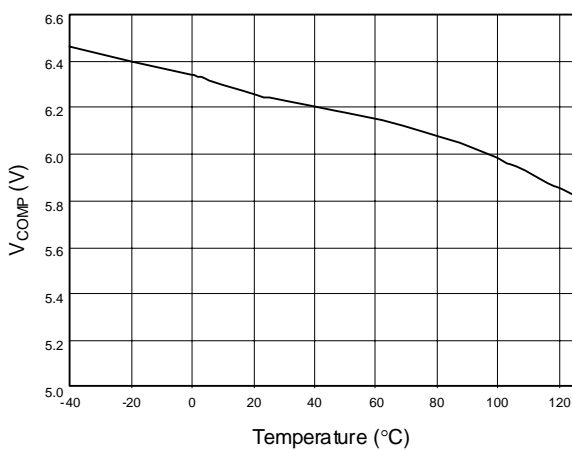


Fig. 11 V<sub>COMP</sub> open loop voltage vs. Temperature

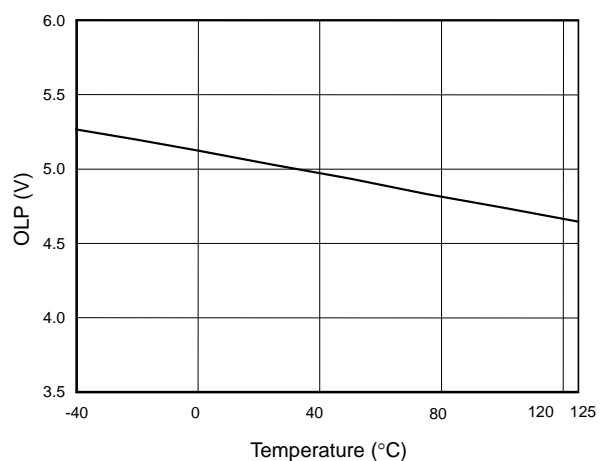


Fig. 12 OLP-Trip Level vs. Temperature

## Application Information

### Operation Overview

As long as the green power requirement becomes a trend and the power saving is getting more and more important for the switching power supplies and switching adaptors, the traditional PWM controllers are not able to support such new requirements. Furthermore, the cost and size limitation force the PWM controllers need to be powerful to integrate more functions to reduce the external part counts. The LD7575B is targeted on such application to provide an easy and cost effective solution; its detail features are described as below:

### Internal High-Voltage Startup Circuit and Under Voltage Lockout (UVLO)

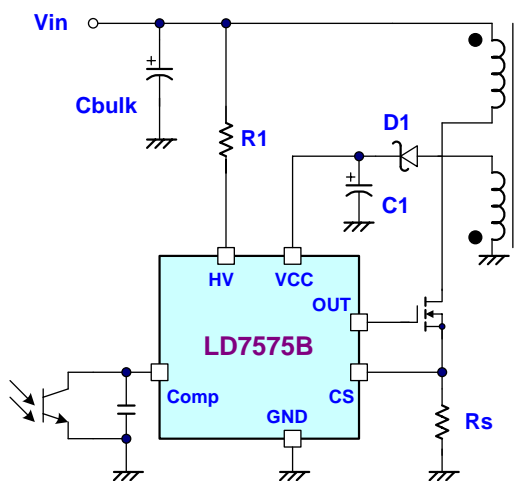


Fig. 13

Traditional circuit powers up the PWM controller through a startup resistor to provide the startup current. However, the startup resistor consumes significant power which is more and more critical whenever the power saving requirement is coming tight. Theoretically, this startup resistor can be very high resistance value. However, higher resistor value will cause longer startup time.

To achieve an optimized topology, as shown in figure 13, LD7575B implements a high-voltage startup circuit for such requirement. During the startup, a high-voltage current source sinks current from the bulk capacitor to provide the startup current as well as charge the Vcc capacitor C1. During the startup transient, the Vcc is lower than the UVLO

threshold thus the current source is on to supply a current with 1mA. Meanwhile, the Vcc supply current is 500 $\mu$ A thus half of the HV current is utilized to charge the Vcc capacitor. Thus start-up time can be calculated as:

$$T_{\text{Start-up}} = 0.032C \text{ Second}$$

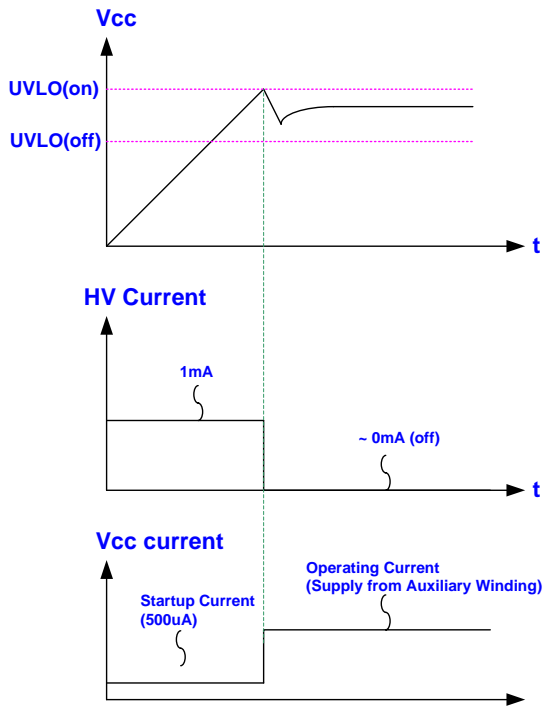
C is capacitance value of C1 in  $\mu$ F

By using such configuration, the turn-on delay time will be almost same no matter under low-line or high-line conditions.

Whenever the Vcc voltage is higher than UVLO(on) to power on the LD7575B and further to deliver the gate drive signal, the high-voltage current source is off and the supply current is provided from the auxiliary winding of the transformer. Therefore, the power losses on the startup circuit can be eliminated and the power saving can be easily achieved.

An UVLO comparator is included to detect the voltage on the Vcc pin to ensure the supply voltage enough to power on the LD7575B PWM controller and in addition to drive the power MOSFET. As shown in Fig. 14, a hysteresis is provided to prevent the shutdown from the voltage dip during startup. The turn-on and turn-off threshold level are set at 16V and 10.0V, respectively.




**Fig. 14**

### Current Sensing, Leading-edge Blanking and the Negative Spike on CS Pin

The typical current mode PWM controller feedbacks both current signal and voltage signal to close the control loop and achieve regulation. The LD7575B detects the primary MOSFET current from the CS pin, which is not only for the peak current mode control but also for the pulse-by-pulse current limit. The maximum voltage threshold of the current sensing pin is set as 0.85V. Thus the MOSFET peak current can be calculated as:

$$I_{PEAK(MAX)} = \frac{0.85V}{R_S}$$

A 220ns leading-edge blanking (LEB) time is included in the input of CS pin to prevent the false-trigger caused by the current spike. In the low power application, if the total pulse width of the turn-on spikes is less than 220ns and the negative spike on the CS pin is not exceed -0.3V, the R-C filter (as shown in figure15) can be eliminated.

However, the total pulse width of the turn-on spike is related to the output power, circuit design and PCB layout. It is strongly recommended to add the small R-C filter (as shown in figure 16) for higher power application to avoid the CS pin damaged by the negative turn-on spike.

### Output Stage and Maximum Duty-Cycle

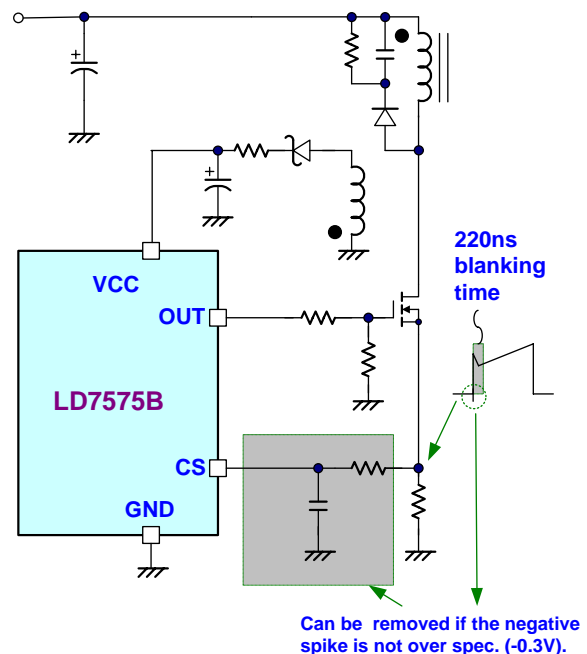
An output stage of a CMOS buffer, with typical 500mA driving capability, is incorporated to drive a power MOSFET directly. And the maximum duty-cycle of LD7575B is limited to 75% to avoid the transformer saturation.

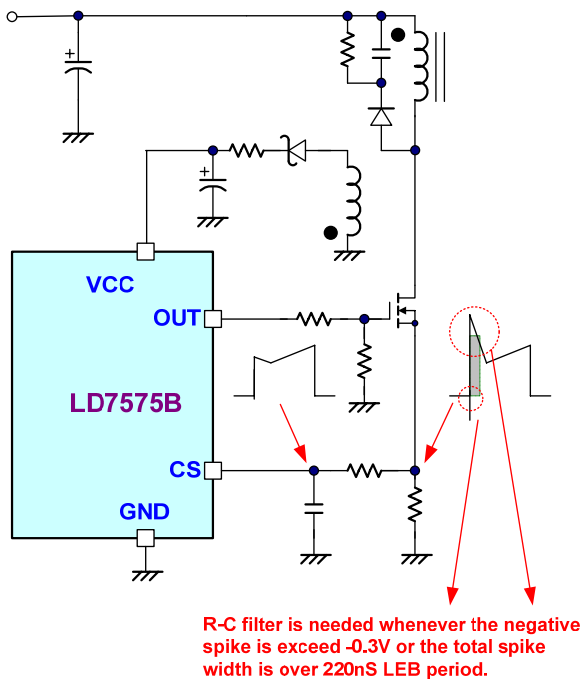
### Voltage Feedback Loop

The voltage feedback signal is provided from the TL431 in the secondary side through the photo-coupler to the COMP pin of LD7575B. The input stage of LD7575B, like the UC384X, is with 2 diodes voltage offset then feeding into the voltage divider with 1/3 ratio, that is,

$$V_{+(PWM_{COMPARATOR})} = \frac{1}{3} \times (V_{COMP} - 2V_F)$$

A pull-high resistor is embedded internally thus can be eliminated on the external circuit.


**Fig. 15**


**Fig. 16**

### Oscillator and Switching Frequency

Connecting a resistor from RT pin to GND according to the equation can program the normal switching frequency:

$$f_{SW} = \frac{65.0}{RT(K\Omega)} \times 100(KHz)$$

The suggested operating frequency range of LD7575B is within 50KHz to 130KHz.

### Internal Slope Compensation

A fundamental issue of current mode control is the stability problem when its duty-cycle is operated more than 50%. To stabilize the control loop, the slope compensation is needed in the traditional UC384X design by injecting the ramp signal from the RT/CT pin through a coupling capacitor. In LD7575B, the internal slope compensation circuit has been implemented to simplify the external circuit design.

### On/Off Control

The LD7575B can be controlled to turn off by pulling COMP pin to lower than 1.2V. The gate output pin of LD7575B will

be disabled immediately under such condition. The off mode can be released when the pull-low signal is removed.

### Dual-Oscillator Green-Mode Operation

There are many difference topologies has been implemented in different chips for the green-mode or power saving requirements such as "burst-mode control", "skipping-cycle Mode", "variable off-time control "...etc. The basic operation theory of all these approaches intended to reduce the switching cycles under light-load or no-load condition either by skipping some switching pulses or reduce the switching frequency.

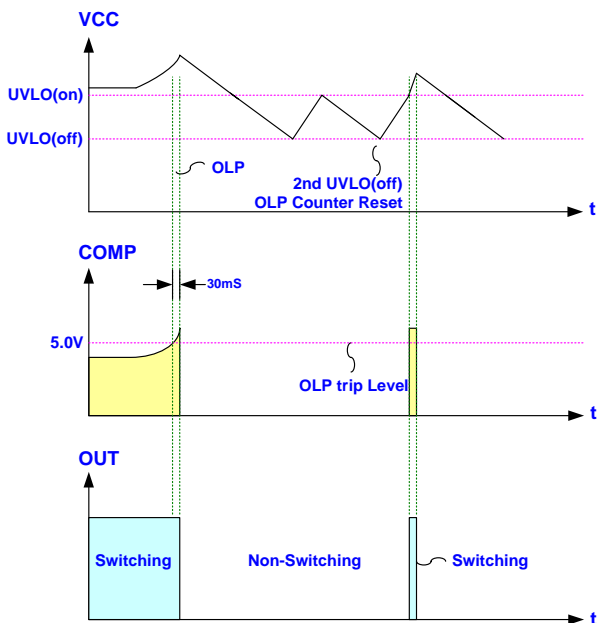
By using this dual-oscillator control, the green-mode frequency can be well controlled and further to avoid the generation of audible noise.

### Over Load Protection (OLP)

To protect the circuit from the damage during over load condition or short condition, a smart OLP function is implemented in the LD7575B. Figure 17 shows the waveforms of the OLP operation. Under such fault condition, the feedback system will force the voltage loop toward the saturation and thus pull the voltage on COMP pin (VCOMP) to high. Whenever the VCOMP trips the OLP threshold 5.0V and keeps longer than 30mS (when switching frequency is 65KHz), the protection is activated and then turns off the gate output to stop the switching of power circuit. The 30mS delay time is to prevent the false trigger from the power-on and turn-off transient.

A divide-2 counter is implemented to reduce the average power under OLP behavior. Whenever OLP is activated, the output is latched off and the divide-2 counter starts to count the number of UVLO(off). The latch is released if the 2nd UVLO(off) point is counted then the output is recovery to switching again.

By using such protection mechanism, the average input power can be reduced to very low level so that the component temperature and stress can be controlled within the safe operating area.

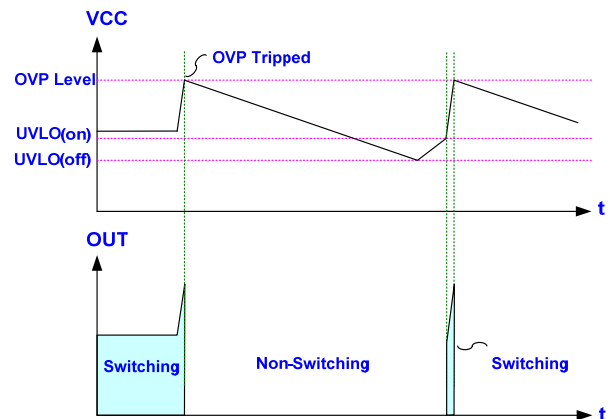

**Fig. 17**

### OVP (Over Voltage Protection) on Vcc

The Vgs ratings of the nowadays power MOSFETs are most with maximum 30V. To prevent the Vgs from the fault condition, LD7575B is implemented an OVP function on Vcc. Whenever the Vcc voltage is higher than the OVP threshold voltage, the output gate drive circuit will be shutdown simultaneous thus to stop the switching of the power MOSFET until the next UVLO(on).

The Vcc OVP function in LD7575B is an auto-recovery type protection. If the OVP condition, usually caused by the feedback loop opened, is not released, the Vcc will tripped the OVP level again and re-shutdown the output. The Vcc is working as a hiccup mode. Figure 18 shows its operation.

On the other hand, if the OVP condition is removed, the Vcc level will get back to normal level and the output is automatically returned to the normal operation.


**Fig. 18**

### Fault Protection

A lot of protection features have been implemented in the LD7575B to prevent the power supply or adapter from being damaged caused by single fault condition on the open or short condition on the pin of LD7575B. Under the conditions listed below, the gate output will be off immediately to protect the power circuit ---

- RT pin short to ground
- RT pin floating
- CS pin floating

### Pull-Low Resistor on the Gate Pin of MOSFET

In LD7575B, an anti-floating resistor is implemented on the OUT pin to prevent the output from any uncertain state which may causes the MOSFET working abnormally or false triggered-on. However, such design won't cover the condition of disconnection of gate resistor Rg thus it is still strongly recommended to have a resistor connected on the MOSFET gate terminal (as shown in figure 19) to provide extra protection for fault condition.

This external pull-low resistor is to prevent the MOSFET from damage during power-on under the gate resistor is disconnected. In such single-fault condition, as show in figure 20, the resistor R8 can provide a discharge path to avoid the MOSFET from being false-triggered by the current through the gate-to-drain capacitor Cgd. Therefore, the MOSFET is always pull-low and kept in the off-state whenever the gate resistor is disconnected or opened in any case.

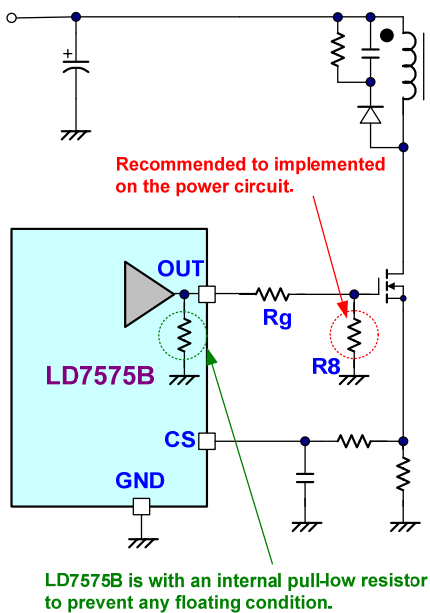


Fig. 19

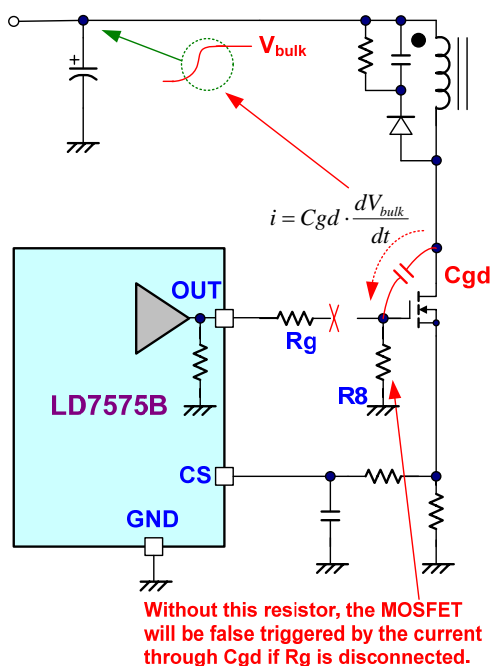


Fig. 20

in figure 21, a small negative spike on the HV pin may trigger this parasitic SCR and causes the latchup between Vcc and GND. And such latchup is easy to damage the chip because of the equivalent short-circuit which is induced by such latchup behavior.

Thanks to the Leadtrend's proprietary Hi-V technology, there is no such parasitic SCR in LD7575B. Figure 22 shows the equivalent circuit of LD7575B's Hi-V structure. So that LD7575B is with higher capability to sustain negative voltage than similar products. However, a 40KΩ resistor is recommended to implement on the Hi-V path to be played the role as a current limit resistor whenever a negative voltage is applied in any case.

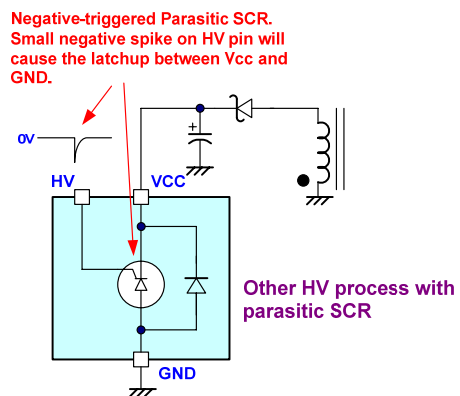


Fig. 21

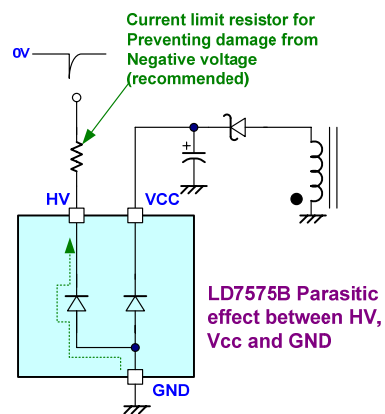


Fig. 22

**Protection Resistor on the Hi-V Path**

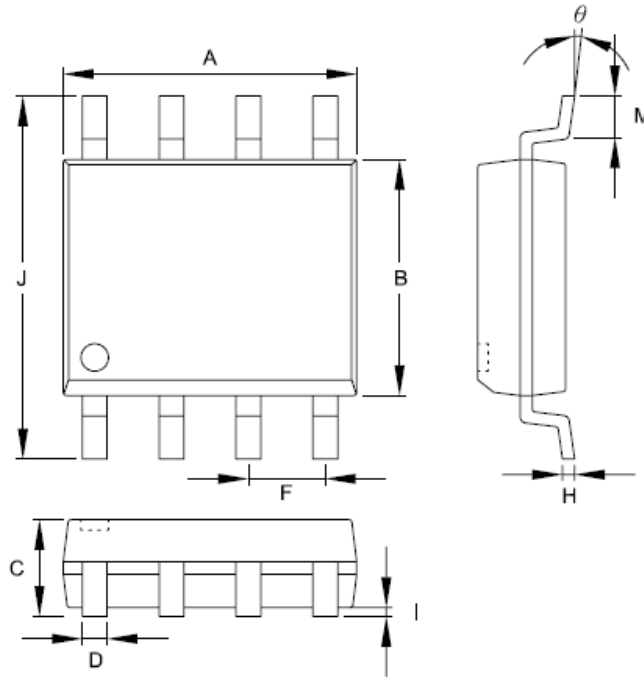
In some other Hi-V process and design, there may cause a parasitic SCR between HV pin, Vcc and GND. As shown



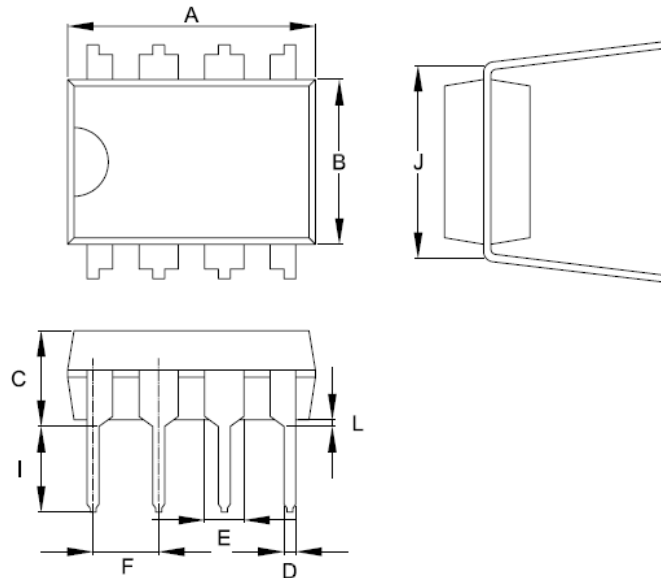
**BOM**

P/N	Component Value	Original
R1A	N/A	
R1B	N/A	
R4A	39K $\Omega$ , 1206	
R4B	39K $\Omega$ , 1206	
R6	2.2 $\Omega$ , 1206	
R7	10 $\Omega$ , 1206	
R8	10K $\Omega$ , 1206	
R9	10K $\Omega$ , 1206	
RS1	2.7 $\Omega$ , 1206, 1%	
RS2	2.7 $\Omega$ , 1206, 1%	
RT	100K $\Omega$ , 0805, 1%	
R51A	100 $\Omega$ , 1206	
R51B	100 $\Omega$ , 1206	
R52	2.49K $\Omega$ , 0805, 1%	
R53	2.49K $\Omega$ , 0805, 1%	
R54	100 $\Omega$ , 0805	
R55	1K $\Omega$ , 0805	
R56A	2.7K $\Omega$ , 1206	
R56B	N/A	
NTC1	5 $\Omega$ , 3A	08SP005
FL1	20mH	UU9.8
T1	EI-22	
L51	2.7 $\mu$ H	

P/N	Component Value	Note
C1	22 $\mu$ F, 400V	L-tec
C2	22 $\mu$ F, 50V	L-tec
C4	1000pF, 1000V, 1206	Holystone
C5	0.01 $\mu$ F, 16V, 0805	
C51	1000pF, 50V, 0805	
C52	1000 $\mu$ F, 10V	L-tec
C54	470 $\mu$ F, 10V	L-tec
C55	0.022 $\mu$ F, 16V, 0805	
CX1	0.1 $\mu$ F	X-cap
CY1	2200pF	Y-cap
D1A	1N4007	
D1B	1N4007	
D1C	1N4007	
D1D	1N4007	
D2	PS102R	
D4	1N4007	
Q1	2N60B	600V, 2A
CR51	SB540	
ZD51	6V2C	
IC1	LD7575B	SOP-8
IC2	EL817B	
IC51	TL431	1%
F1	250V, 1A	
Z1	N/A	

**Package Information**
**SOP-8**


Symbols	Dimensions in Millimeters		Dimensions in Inch	
	MIN	MAX	MIN	MAX
A	4.801	5.004	0.189	0.197
B	3.810	3.988	0.150	0.157
C	1.346	1.753	0.053	0.069
D	0.330	0.508	0.013	0.020
F	1.194	1.346	0.047	0.053
H	0.178	0.229	0.007	0.009
I	0.102	0.254	0.004	0.010
J	5.791	6.198	0.228	0.244
M	0.406	1.270	0.016	0.050
$\theta$	0°	8°	0°	8°

**Package Information**
**DIP-8**


Symbol	Dimension in Millimeters		Dimensions in Inches	
	Min	Max	Min	Max
A	9.017	10.160	0.355	0.400
B	6.096	7.112	0.240	0.280
C	-----	5.334	-----	0.210
D	0.356	0.584	0.014	0.023
E	1.143	1.778	0.045	0.070
F	2.337	2.743	0.092	0.108
I	2.921	3.556	0.115	0.140
J	7.366	8.255	0.29	0.325
L	0.381	-----	0.015	-----

**Important Notice**

Leadtrend Technology Corp. reserves the right to make changes or corrections to its products at any time without notice. Customers should verify the datasheets are current and complete before placing order.





**Revision History**

Rev.	Date	Change Notice
00	5/26/2008	Original Specification.