

Thermowell for temperature sensors *omnigrad M TW 10*

Pipe thermowell Threaded process connection



Omnigrad M TW 10 thermowells are designed for the use in the fine chemicals industry but can also be used for generic applications.

Thanks to its modular configuration, defined in standard DIN 43772 (form 2G/3G), the TW 10 thermowell is suitable for almost all industrial processes.

Features and benefits

- SS 316L/1.4404, SS 316Ti/1.4571 and Hastelloy C for the "wetted" parts
- The common threaded process connections are supplied as standard; others are available on request
- Customized immersion length
- Surface finishing $R_a < 0.8 \mu\text{m}$
- Tip of the thermowell with a reduced diameter or tapered for a faster response time
- Material certification (3.1.B)
- Pressure test
- Test with penetrant liquids on welds

Areas of application

- Fine chemicals industry
- Light energy industry
- Food industry
- General industrial services

Function and system design

Equipment architecture

The design of the thermowell is based on standard DIN 43772 and can therefore guarantee a good level of resistance to the most typical and common industrial processes.

The thermowell is made from a tube with a diameter of 9, 11 or 12 mm. The final part can be straight, tapered (i.e. with a gradual reduction of the stem achieved thanks to a swaging procedure), or reduced (stepped).

The Omnigrad M TW 10 thermowell can be fitted on the plant (tube or tank) using a threaded connection, which can be chosen from the most common models (see section "Structure of components").

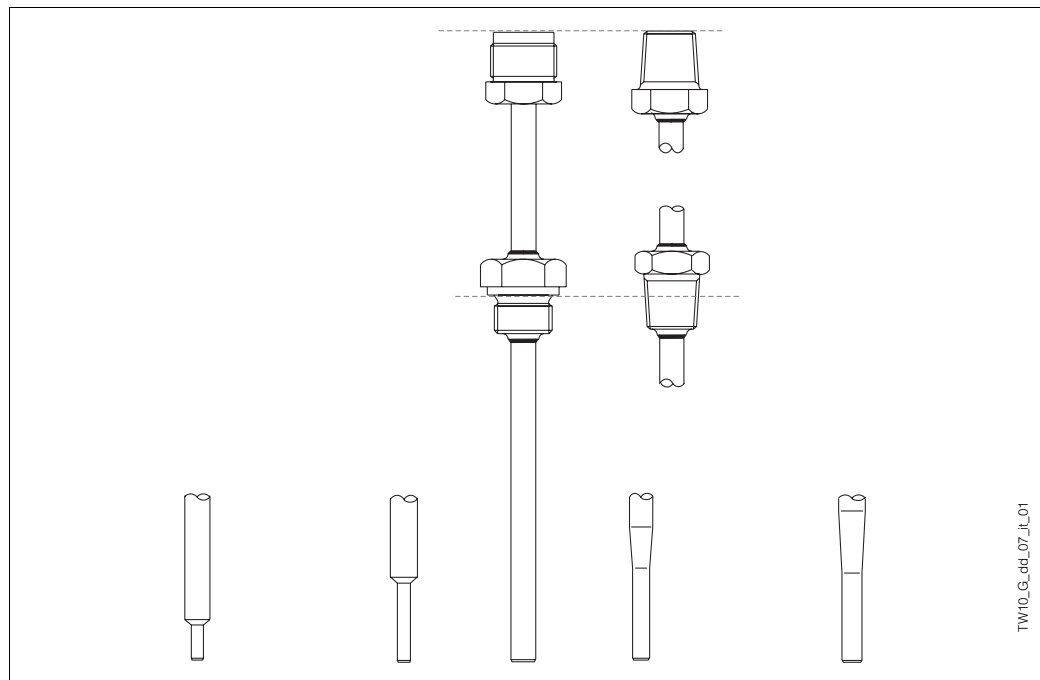

Fig. 1: TW 10 with several types of process connections and end parts of the thermowell

Material

Wetted parts in SS 316L/1.4404, SS 316Ti/1.4571 or Hastelloy C.

Weight

From 0.5 to 2 Kg for standard options.

Performance

Operating conditions

Process temperature

- 316L/1.4404
- 316Ti/1.4571
- Hastelloy C

-200 ÷ 600°C
 -200 ÷ 800°C
 -200 ÷ 1000°C

Maximum process pressure

The pressure values to which the thermowell can be subjected at varying temperatures are illustrated in the drawings of figures 2 and 3. A possible limitation can originate from process connections. For tubes with a diameter of 9 mm, with a limited flow rate, the thermowell can tolerate the following maximum pressures:

- 50 bar
- 33 bar
- 24 bar

at 20°C
 at 250°C
 at 400°C.

Maximum flow velocity

The highest flow velocity tolerated by the thermowell decreases as the length of the well/probe, exposed to the stream of the fluid, increases. Some information is provided in the drawing of figures 2 and 3.

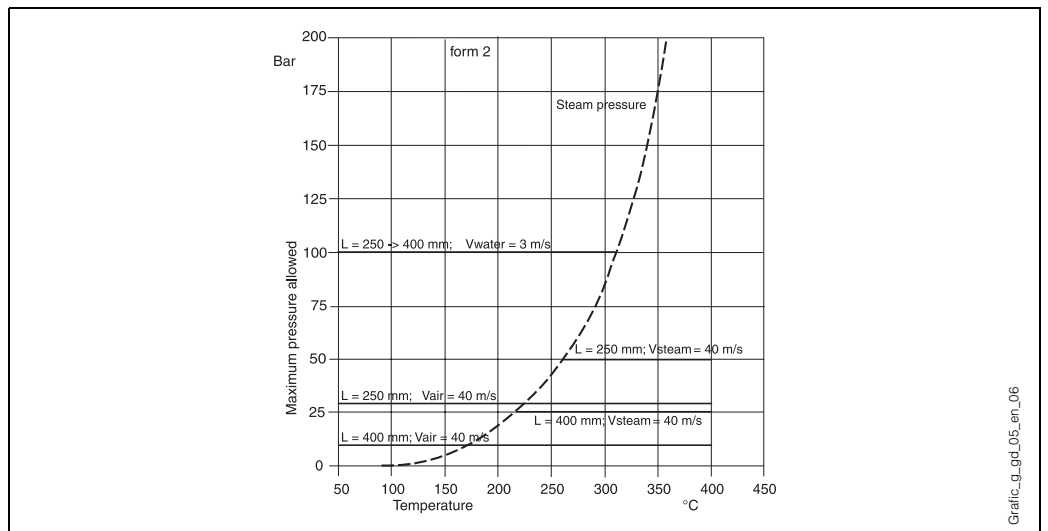

Fig. 2: Pressure/temperature drawing for thermowell with a straight pipe Ø 11 mm in SS 316Ti/1.4571

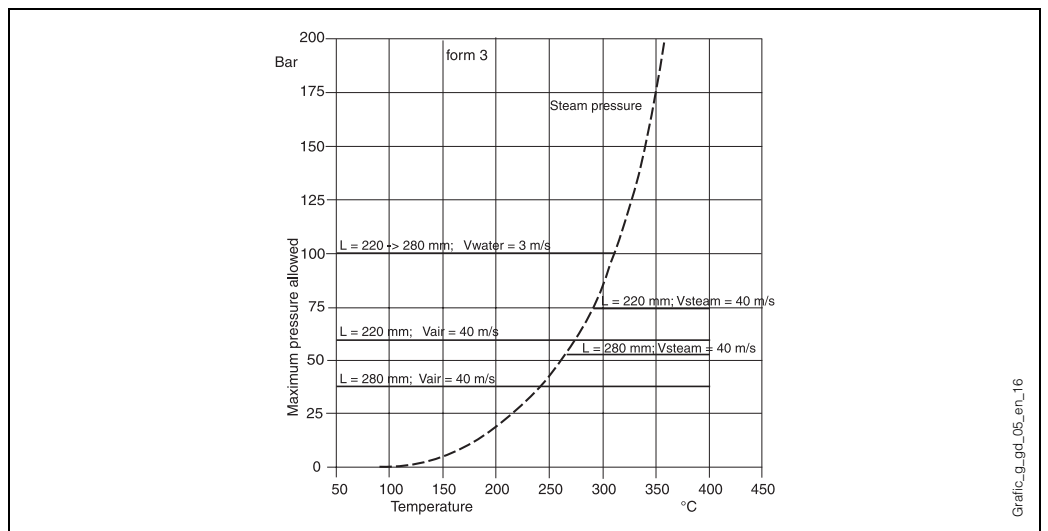

Fig. 3: Pressure/temperature drawing for thermowell with tapered pipe Ø12 mm in SS 316Ti/1.4571

Installation

The Omnigrad M TW 10 thermowells can be mounted on the wall of pipes or vessels or other plant parts that may require them.

The interface components for the process connection and the related gaskets are not normally provided with the sensors and must be purchased by the customer.

Immersion length may influence the accuracy of the measurement. If the immersion length is too low, an error may be generated in the temperature recorded due to the lower temperature of the process fluid near to the walls and heat transfer, which takes place through the sensor stem. The incidence of such an error can be relevant if there is a large difference between the process temperature and ambient temperature. In order to avoid this source of inaccuracy, the thermowell should have a small diameter and the immersion length (L) should be, if possible, at least $80 \div 100$ mm. For pipes with a small section, it is necessary to make sure that the tip of the probe reaches or slightly exceeds, if possible, the axis line of the duct (see fig. 4A-4B). Insulation of the outer part of the sensor reduces the effect produced by a low immersion length. Another solution may be a tilted installation (see fig. 4C-4D). For use in the food industry, it is best to follow the rule $h \leq d/2$.

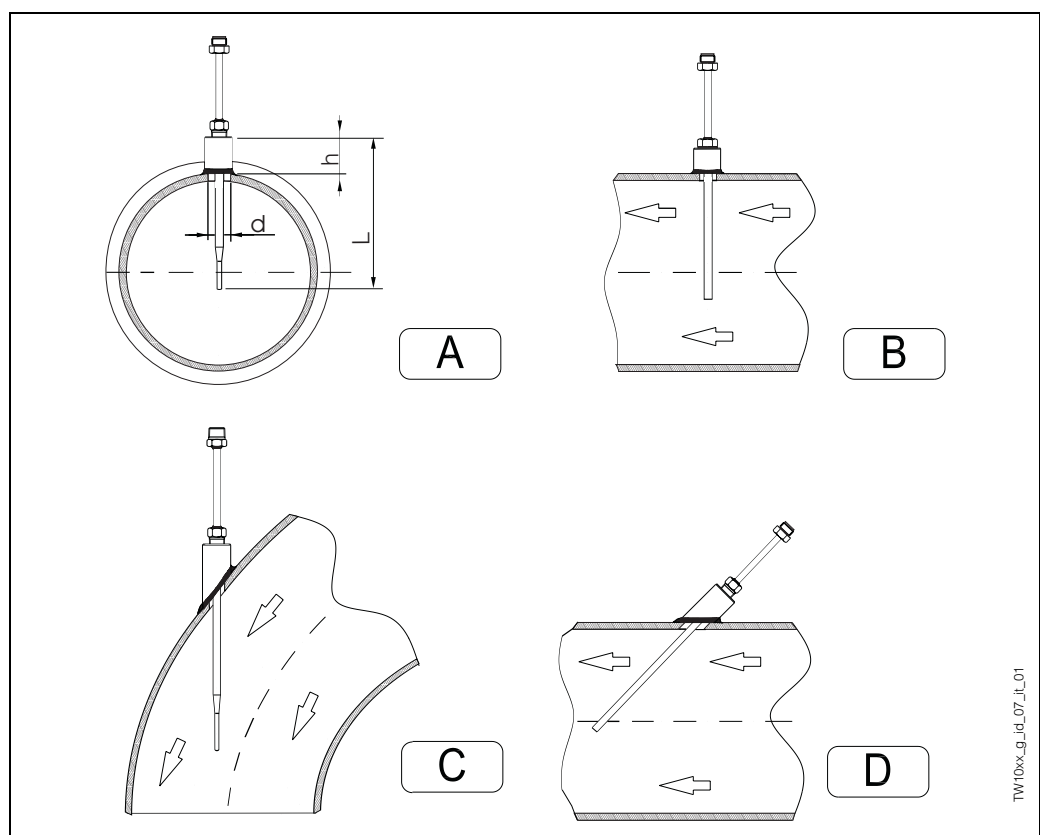

Fig. 4: Installation examples

With regard to corrosion, the base material of the wetted parts (SS 316L/1.4404, SS 316Ti/1.4571, Hastelloy C) can tolerate the common corrosive media right up to even the highest temperatures. For further information on specific applications, please contact the E+H Customer Service.

System components

Extension neck

The extension neck is the part between the process connection and the housing. It is normally made of a tube with the same dimensional and physical characteristics (diameter and material) of the tube under the process connection.

The standard lengths of the neck are 80 or 145 mm, according to the selected option.

Attention!

In accordance with standard DIN 43772, in the case of a thermowell with a diameter of 12 mm and a tapered tip (form 3G), the extension neck will be respectively 87 or 147 mm.

The M24x1.5 connection, situated in the upper part of the neck, enables to orient the head of the sensor. This option is not available with 1/2" NPT fittings.

Process connection

Standard connections are available in the following types:

- M20x1.5
- G 1/2" and G 1" DIN 43772 (DIN 3852 form A)
- G 1/2", G 3/4" and G 1" BSP cylindrical
- 1/2" and 3/4" NPT.

Other versions may be supplied on request.

Figure 5 shows the engaging lengths.

Process connections	Thread	mm	
	C	G 1/2" DIN	15
		G 1" DIN	18
		G 1/2" BSP	15
		G 3/4" BSP	15
		G 1" BSP	20
		M 20X1.5	14
	D	1/2" NPT	8
		3/4" NPT	8.5

Fig. 5: Engaging lengths

The immersion length of the part of tube in contact with the process fluid is available in the dimensions indicated in standard DIN 43772 and in the most commonly used ones. Immersion length can also be customised within a range of values (see "Sales structure" at the end of this document).

The surface finish (Ra) is 0.8 µm. The different types of tips (reduced or tapered) are described in figure 6.

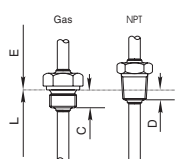
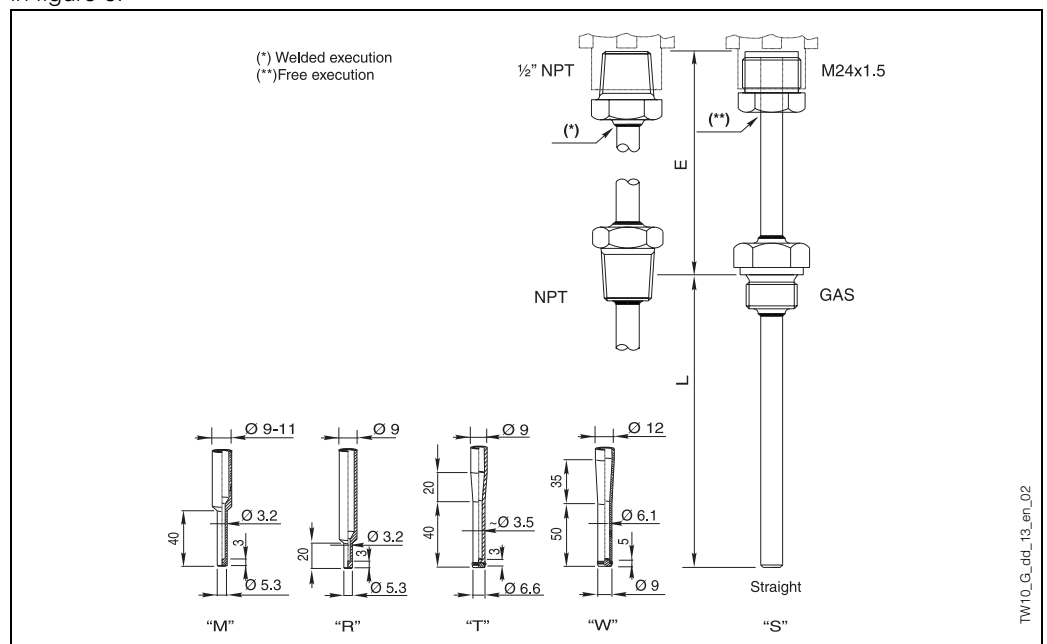

Fig. 6: Functional components

Certificates & approvals

PED approval

The Pressure Equipment Directive (97/23/CE) is respected. As paragraph 2.1 of article 1 is not applicable to this kind of instruments, the marking is not mandatory for TW 10 models used for generic applications.

Material certification

The material certificate 3.1.B (compliant standard EN 10204) can be directly selected from the sale structure of the product and refers to the parts of the thermowell in contact with the process fluid. Other types of certificates related to materials can be requested separately.

The "short form" certificate includes a simplified declaration, with no enclosures of documents, related to the materials used in the construction of the single thermowell and guarantees the traceability of the materials through the identification number of the thermometer. The data related to the origin of the materials can subsequently be requested by the customer if necessary.

Test on the thermowell

The pressure tests are carried out at ambient temperature in order to verify the resistance of the thermowell to the specifications indicated by standard DIN 43772. For thermowells that do not comply with this standard (with a reduced tip, a tapered tip on a 9 mm tube, special dimensions ...), the pressure of the corresponding straight tube with similar dimensions is verified.

Tests at different pressures can be carried out on request.

The liquid (dye) penetrant test verifies the absence of crevices on the weldings of the thermowell.

Further details

Maintenance

Omnigrad M TW 10 thermowells do not require specific maintenance.

Delivery time

For small quantities (10 ÷ 20 units) and standard options, between 5 and 15 days depending on the configuration required.

Ordering information

Sale structure

TW10	Head connection		
	1	M24x1.5 head connection	
	2	1/2" NPT head connection	
	Pipe diameter, type of material		
	A	Pipe diameter: 9 mm, material: SS 316L/1.4404	
	D	Pipe diameter: 9 mm, material: SS 316Ti/1.4571	
	G	Pipe diameter: 9 mm, material: Hastelloy C	
	B	Pipe diameter: 11 mm, material: SS 316L/1.4404	
	E	Pipe diameter: 11 mm, material: SS 316Ti/1.4571	
	H	Pipe diameter: 11 mm, material: Hastelloy C	
	F	Pipe diameter: 12 mm, material: SS 316Ti/1.4571	
	Y	Special version	
	Neck length E (60-250 mm)		
	1	80 mm, extension neck E (82 mm with tip "W")	
	3	145 mm, extension neck E (147 mm with tip "W")	
	8	... mm, neck length E to specify	
	9	... mm, special neck length E	
	Process connection and material		
	<i>(the material must be the same as the material of the pipe)</i>		
	BG	M20X1.5 process connection, material: SS 316Ti	
	BH	G 1/2" A DIN 43772 process connection, material: SS 316Ti	
	BJ	G 1" A DIN 43772 process connection, material: SS 316Ti	
	CA	G 1/2" BSP (cyl.) process connection, material: SS 316L	
	CB	G 3/4" BSP (cyl.) process connection, material: SS 316L	
	CC	G 1" BSP (cyl.) process connection, material: SS 316L	
	CD	1/2" NPT process connection, material: SS 316L	
	CE	3/4" NPT process connection, material: SS 316L	
	HH	G 1/2" A DIN 43772 process connection, material: Hastelloy C	
	HD	1/2" NPT process connection, material: Hastelloy C	
	YY	Special version	
	Tip design		
	S	Straight tip	
	R	Reduced tip, L >= 60 mm (SS 9 mm pipe)	
	M	Reduced tip, L >= 80 mm (9 and 11 mm pipes)	
	T	Tapered tip, L >= 100 mm (SS 9 mm pipe)	
	W	Tapered tip, L >= 120 mm in compliance with DIN 43772 form 3G (from 12 mm pipe in SS 316Ti, with length E from 82 to 147 mm)	
	Y	Special version	
	Immersion length (50 - 3700 mm)		
	A	70 mm, immersion length L	
	C	120 mm, immersion length L	
	D	160 mm, immersion length L	
	E	220 mm, immersion length L	
	F	250 mm, immersion length L	
	G	280 mm, immersion length L	
	H	310 mm, immersion length L	
	J	400 mm, immersion length L	
	K	580 mm, immersion length L	
	X	... immersion length L to specify	
	Y	... special immersion length L	
	Material certification		
	0	Material certification not required	
	1	3.1.B EN10204 certificate for wetted part	
	2	3.1.B EN10204, "short form" for wetted parts	
	9	Special version	
	Test on thermowell		
	0	Tests on thermowell not required	
	A	Hydrostatic internal pressure test on the thermowell	
	B	Hydrostatic external pressure test on the thermowell	
	C	Dye penetrant test on thermowell weldings	
	Y	Special version	
TW10-			Complete order code

Supplementary documentation

<input type="checkbox"/> TA series - general information	TI 138T/02/en
<input type="checkbox"/> Liquid penetrant test for thermowells	TI 168T/02/en
<input type="checkbox"/> Hydrostatic test for thermowells	TI 169T/02/en
<input type="checkbox"/> Terminal housings - Omnigrad TA 20	TI 072T/02/en
<input type="checkbox"/> RTD insert for temperature sensors - Omniset TPR 100	TI 268T/02/en

Subject to modifications

Endress+Hauser
GmbH+Co.
Instruments International
P.O. Box 2222
D-79574 Weil am Rhein
Germany

Tel. (07621) 975-02
Tx 773926
Fax (07621) 975 345
<http://www.endress.com>
info@ii.endress.com

Endress + Hauser
People for Process Automation

