



Level



Pressure



Flow



Temperature

Liquid  
Analysis

Registration

Systems  
Components

Services



Solutions

## Technical Information

# Omnigrad M TR47, TR48

Hygienic, modular RTD assembly for weld-in installation

Various process connections and fast response time



### Application

- All hygienic applications for food, pharmaceutical and fine chemicals industry
- Made up of a measurement probe, with (TR47) or without (TR48) a thermowell and a housing, which may contain the transmitter for the conversion of the measured variable.
- Installation by welding, which is carried out on the (TR47) thermowell or on a spherical process connection (TR48).

### Head transmitters

All Endress+Hauser transmitters are available with enhanced accuracy, reliability and cost effectiveness compared to directly wired sensors. Easy customizing by choosing one of the following outputs and protocols:

- Analog output 4...20 mA
- HART®
- PROFIBUS® PA
- FOUNDATION Fieldbus™

### Features and benefits

- 3-A® certification
- SS 316L/1.4435 for "wetted" parts (BN 2 compliance on request)
- Customized immersion length (TR48)
- Fast response time
- High pressure resistance
- Surface finishing down to Ra < 0.4 µm, with or without electro-polishing
- Stainless steel, aluminum or plastic housing, all of which are easily cleanable and a minimum of IP65 (IP68 available)
- Replaceable mineral insulated insert (TR47)
- Highest accuracy with Pt100 sensors according to IEC 60751
- Double Pt 100, for redundancy or validation purposes
- ATEX 1 or 1/2 GD EEx ia certification (TR47)
- Material certification 3.1
- EA calibration certificate
- Ferrite content determination
- TR47 supplied with or without thermowell



## Function and system design

### Measuring principle

In the Platinum RTD (Resistance Temperature Detector) thermometers the sensing element consists of an electrical resistance with value of  $100\ \Omega$  at  $0\ ^\circ\text{C}$  (called Pt100, in compliance with standard IEC 60751), which increases at higher temperatures according to a coefficient characteristic of the resistor material (platinum). In industrial thermometers that comply with the IEC 60751 standard, the value of this coefficient is  $\alpha = 3.85 \cdot 10^{-3}\ ^\circ\text{C}^{-1}$ , calculated between  $0$  and  $100\ ^\circ\text{C}$ .

### Equipment architecture

The Omnigrad M TR47 and TR48 temperature assemblies are made up of a measurement probe, with (TR47) or without (TR48) a thermowell, and a housing (head), which may contain a transmitter or the terminals for the electrical connection.

In the TR47, the probe is a sensing insert, which is placed inside the thermowell and spring loaded to its base in order to improve heat transfer.

As in the TR48, the sensing element (Pt 100) is positioned close to the tip of the probe.

The thermowell (TR47) is manufactured from a solid stainless steel bar, which when welded correctly to the plant, is able to withstand very high operating pressures. The final (sensing) part of the well is reduced (stepped).

The sheath of the probe in the TR48 is obtained from a 6 mm pipe, which tapers to 4.5 mm in the last 18 mm of the stem.

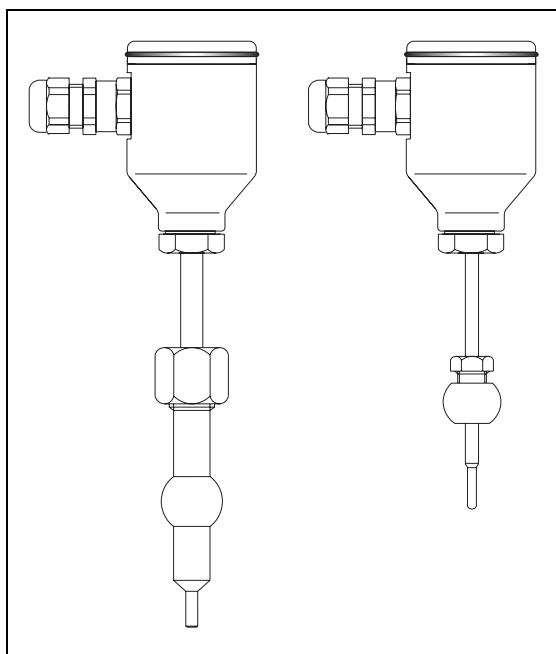

The process connection in the TR48 is a fixed position compression fitting and its external spherical surface must be welded onto the plant. The press-fit effect is obtained via an internal sealing ring (sleeve).

Both TR47 and TR48 are built to 3-A<sup>®</sup> design criteria, which allow the sensor to withstand any stress caused by CIP (Cleaning In Place) and SIP (Sterilization In Place) processes.

The electrical structure of the instruments always complies with IEC 60751 standard rules. The housing can be of different types and materials (plastic, painted aluminium, stainless steel). The way in which it fits to the rest of the probe and the gland for the cable entry ensures a minimum grade of IP65 (Ingress Protection).

The TR47 is supplied with or without the thermowell. This option is particularly important when the well must be mounted on the plant prior to the purchase of the measuring instruments.

TR47 (left) and TR48 (right)

### Measurement range

According to IEC 60751:

- TR47:  $-50 \dots 400\ ^\circ\text{C}$  ( $-58 \dots 752\ ^\circ\text{F}$ )
- TR48:  $-50 \dots 200\ ^\circ\text{C}$  ( $-58 \dots 392\ ^\circ\text{F}$ )

## Performance characteristics

### Operating conditions

#### Ambient temperature

Terminal head	Temperature in $^\circ\text{C}$ ( $^\circ\text{F}$ )
Without mounted head transmitter	<ul style="list-style-type: none"> <li>■ Housing, material aluminum <math>-40</math> to <math>100\ ^\circ\text{C}</math> (<math>-40</math> to <math>212\ ^\circ\text{F}</math>)</li> <li>■ Housing, material polyamide <math>-40</math> to <math>85\ ^\circ\text{C}</math> (<math>-40</math> to <math>185\ ^\circ\text{F}</math>)</li> </ul>
With mounted head transmitter	$-40$ to $85\ ^\circ\text{C}$ ( $-40$ to $185\ ^\circ\text{F}$ )
With mounted head transmitter and display	$-20$ to $70\ ^\circ\text{C}$ ( $-4$ to $158\ ^\circ\text{F}$ )

**Maximum process pressure**

- TR47:
  - 17 MPa (170 bar) at 20 °C
  - 13 MPa (130 bar) at 150 °C
- TR48
  - PTFE sleeve: 7.5 MPa (75 bar) at 20 °C
  - Peek sleeve: 14 MPa (140 bar) at 20 °C
  - SS sleeve: 10 MPa (100 bar) at 20 °C

**Maximum flow velocity**

The highest flow velocity tolerated by the sensor stem diminishes with increasing lengths of the well/probe exposed to the stream of fluid.

**Shock and vibration resistance** 2,8 g peak / 10 to 500 Hz as per IEC 60068-2-6

**Accuracy** RTD corresponding to IEC 60751

Class	max. Tolerances (°C)	Temperature range	Characteristics
<b>RTD maximum error type TF - range: -50 to +400 °C</b>			
F0.15 (Cl. A)	1) $0.15 \pm 0.002 \cdot  t ^{1)}$	-50 °C to +250 °C	
F0.1 (1/3 Cl. B)	$0.10 \pm 0.0017 \cdot  t ^{1)}$	0 °C to +150 °C	
F0.3 (Cl. B)	$0.3 \pm 0.005 \cdot  t ^{1)}$	-50 °C to +400 °C	

1. |t| = absolute value °C



**Note!**

For measurement errors in °F, calculate using equations above in °C, then multiply the outcome by 1.8.

**Response time**

Tests of the sensor assemblies without transmitter in water at 0.4 m/s (1.3 ft/s), according to IEC 60751; 10 K temperature step changes:

Sensor type	Response time	Without thermoconductive paste	With thermoconductive paste
TR47	t <sub>50</sub>	5 s	4 s
	t <sub>90</sub>	13 s	11 s
TR48	t <sub>50</sub>	3 s	-
	t <sub>90</sub>	10 s	-

**Insulation resistance**

Insulation resistance  $\geq 100 \text{ M}\Omega$  at ambient temperature.

Insulation resistance between each terminal and the sheath is tested with a voltage of 100 V DC.

**Self heating**

RTD elements are passive resistances that are measured using an external current. This measurement current causes a self heating in the RTD element itself which in turn creates an additional measurement error. In addition to the measurement current the size of the measurement error is also affected by the thermal conductivity and flow velocity of the process. This self heating error is negligible when an Endress+Hauser iTEMP<sup>®</sup> temperature transmitter (very small measurement current) is connected.

**Calibration specifications**

Endress+Hauser provides comparison temperature calibration from -80 to +600 °C (-110 °F to 1112 °F) based on the International Temperature Scale (ITS90). Calibrations are traceable to national and international standards. The calibration report is referenced to the serial number of the thermometer.

TR47 (with replaceable insert) TR48 (without replaceable insert)	Minimum standard immersion length L in mm (inch)	
	without head transmitter	with head transmitter (thermometer without neck)
Temperature range		
-80 °C to -40 °C (-110 °F to -40 °F)	200 (7.9)	
-40 °C to 0 °C (-40 °F to 32 °F)	160 (6.3)	
0 °C to 250 °C (32 °F to 480 °F)	120 (4.7)	150 (5.9)

**Material**

Material	Short description	max. application temperature	Characteristics
SS 316L/ 1.4404/1.4435	X2CrNiMo 17 13 2	800 °C (1472 °F)	<ul style="list-style-type: none"> <li>■ Austenitic, stainless steel</li> <li>■ High corrosion resistance</li> <li>■ High resistance at low temperatures</li> <li>■ Optimal corrosion resistance in an acid, non oxidizing environment (e.g. phosphorous and sulphuric acids in low concentration and at low temperatures)</li> <li>– Not resistant to chloride at high temperatures</li> </ul>

**Transmitter specifications**

	TMT180 PCP Pt100	TMT181 PCP Pt100, TC, Ω, mV	TMT182 HART <sup>®</sup> Pt100, TC, Ω, mV	TMT84 PA / TMT85 FF Pt100, TC, Ω, mV
Measurement accuracy	0.2 °C (0.36 °F), optional 0.1 °C (0.18 °F) or 0.08%	0.2 °C (0.36 °F) or 0.08%		0.1 °C (0.18 °F)
	% is related to the adjusted measurement range (the larger value applies)			
Sensor current	I ≤ 0.6 mA		I ≤ 0.2 mA	I ≤ 0.3 mA
Galvanic isolation (input/output)	-		Û = 2 kV AC	

**System components****Family of temperature transmitters**

Thermometers fitted with iTEMP<sup>®</sup> transmitters are an installation ready complete solution to improve temperature measurement by increasing accuracy and reliability, when compared to direct wired sensors, as well as reducing both wiring and maintenance costs.

**PC programmable head transmitter TMT180 and TMT181**

They offer you extreme flexibility and help control costs with the ability to stock devices and program them for your needs. Regardless of your choice of output, all iTEMP<sup>®</sup> transmitters can be configured quickly and easily with a PC. To help you with this task, Endress+Hauser offers free software ReadWin<sup>®</sup> 2000 which can be downloaded from the website [www.readwin2000.com](http://www.readwin2000.com). Details see Technical Information (see chapter 'Documentation').

**HART® TMT182 head transmitter**

HART® communication is all about easy, reliable data access and getting better information more inexpensively. iTEMP® transmitters integrate seamlessly into your existing control system and provide painless access to preventative diagnostic information.

Configuration with a DXR275 or 375 hand-held or a PC with configuration program (FieldCare, ReadWin® 2000) or configure with AMS or PDM. Details see Technical Information (see chapter 'Documentation').

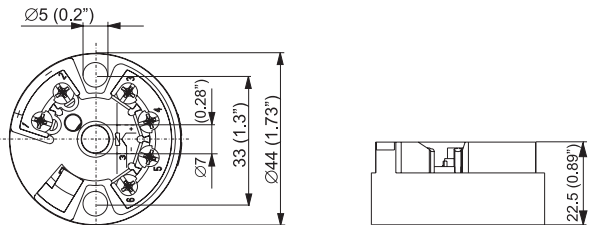
Type of transmitter	Specification
<p>iTEMP® TMT18x</p>  <p style="text-align: right; font-size: small;">R09-TMT182ZZ-06-06-xx-en-001</p>	<ul style="list-style-type: none"> <li>■ Material: Housing (PC), Potting (PUR)</li> <li>■ Terminals: Cable up to max. <math>\leq 2.5 \text{ mm}^2 / 16 \text{ AWG}</math> (secure screws) or with wire end ferrules</li> <li>■ Eyelets for easy connection of a HART®-handheld terminal with alligator clips</li> <li>■ Degree of protection NEMA 4 (see also type of terminal head)</li> </ul> <p>Details see Technical Information (see chapter 'Documentation')</p>

**PROFIBUS® PA TMT84 head transmitter**

Universally programmable head transmitter with PROFIBUS® PA communication. Converting various input signals into a digital output signal. High accuracy over the complete ambient temperature range. Swift and easy operation, visualization and maintenance using a PC directly from the control panel, e. g. using operating software such as FieldCare, Simatic PDM or AMS.

Benefits are: dual sensor input, highest reliability in harsh industrial environments, mathematic functions, thermometer drift monitoring, sensor back-up functionality, sensor diagnosis functions and sensor-transmitter matching using Callendar-Van Dusen coefficients. Details see Technical Information (see chapter 'Documentation').

**FOUNDATION Fieldbus™ TMT85 head transmitter**

Universally programmable head transmitter with FOUNDATION fieldbus™ communication. Converting various input signals into a digital output signal. High accuracy over the complete ambient temperature range. Swift and easy operation, visualization and maintenance using a PC directly from the control panel, e. g. using operating software such as ControlCare from Endress+Hauser or the NI Configurator from National Instruments.

Benefits are: dual sensor input, highest reliability in harsh industrial environments, mathematic functions, thermometer drift monitoring, sensor back-up functionality, sensor diagnosis functions and sensor-transmitter matching using Callendar-Van Dusen coefficients. Details see Technical Information (see chapter 'Documentation').

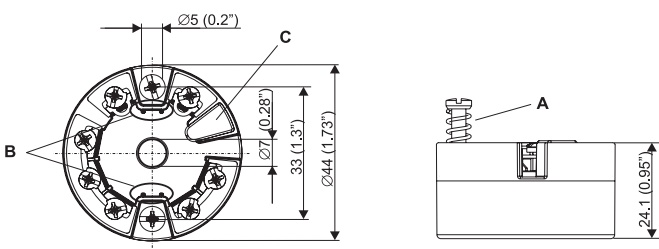
Type of transmitter	Specification
<p>iTEMP® TMT84 and TMT85</p>  <p style="text-align: right; font-size: small;">a0007301-en</p>	<ul style="list-style-type: none"> <li>■ Spring range <math>L \geq 5 \text{ mm (0.2\"}</math>), see Pos. A</li> <li>■ Fixing elements for pluggable measured value display, see Pos. B</li> <li>■ Interface for contacting measured value display, see Pos. C</li> <li>■ Material (RoHS-compliant) Housing: PC Potting: PU</li> <li>■ Terminals: Screw terminals (cable up to max. <math>\leq 2.5 \text{ mm}^2 / 16 \text{ AWG}</math>) or spring terminals (e. g. from <math>0.25 \text{ mm}^2</math> to <math>0.75 \text{ mm}^2 / 24 \text{ AWG}</math> to 18 AWG for flexible wires with wire-end ferrules with plastic ferrule)</li> <li>■ Degree of protection NEMA 4 (see also type of terminal head)</li> </ul> <p>Details see Technical Information (see chapter 'Documentation')</p>

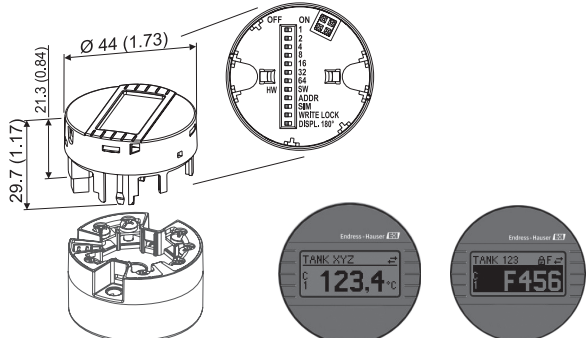
Type of transmitter	Specification
<p>Pluggable display TID10 as option</p>  <p style="text-align: right; font-size: small;">a0009955</p>	<ul style="list-style-type: none"> <li>■ Displays the actual measured value and the measurement point identification</li> <li>■ Displays fault events in inverse color with channel ident and diagnostics code</li> <li>■ DIP-switches on the rear for hardware set-up, e. g. PROFIBUS® PA bus address</li> </ul>

**Terminal heads**

All terminal heads have internal geometry according to DIN 43729, form B and thermometer connection M24x1.5.  
 All dimensions in mm (inch). All cable gland dimensions in the graphics are based on SKINTOP ST M20x1.5

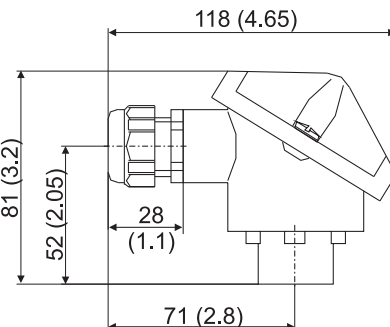
TA20A	Specification
 <p style="text-align: right; font-size: small;">a0008650</p>	<ul style="list-style-type: none"> <li>■ Degree of protection: IP66</li> <li>■ Tapped hole spacing: 33 mm (1.30") for the measuring insert</li> <li>■ Max. temperature: 100 °C (212 °F)</li> <li>■ Material: aluminum alloy, rubber seal under the cover</li> <li>■ Cable entry: G ½", NPT ½", M12x1 PA or M20x1.5</li> <li>■ Protection armature connection: M24x1.5, NPT ½" or G ½"</li> <li>■ Head color: blue RAL 5012, epoxy resin coating</li> <li>■ Cap color: grey RAL 7035, epoxy resin coating</li> <li>■ Weight: 180 g (6.35 oz)</li> <li>■ 3-A® certified</li> </ul>

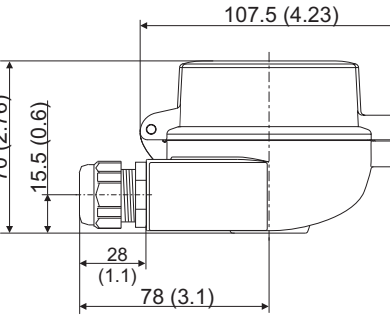
TA30A	Specification
 <p style="text-align: right; font-size: small;">a0009820</p>	<ul style="list-style-type: none"> <li>■ Degree of protection: IP66/68</li> <li>■ Tapped hole spacing: 33 mm (1.30") for the measuring insert</li> <li>■ Max. temperature: 150 °C (300 °F)</li> <li>■ Material: aluminum, polyester powder coated</li> <li>■ Seals: Silicone</li> <li>■ Cable entry incl. glands: ½" NPT and M20x1.5, only thread: G ½", plugs: M12x1 PA, 7/8" FF</li> <li>■ Protection armature connection: M24x1.5</li> <li>■ Head color: blue RAL 5012</li> <li>■ Cap color: grey RAL 7035</li> <li>■ Weight: 330 g (11.64 oz)</li> </ul>

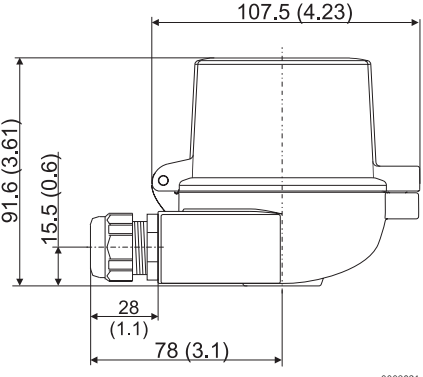
TA30A with display window	Specification
 <p style="text-align: right; font-size: small;">a0009821</p>	<ul style="list-style-type: none"> <li>■ Degree of protection: IP66/68</li> <li>■ Tapped hole spacing: 33 mm (1.30") for the measuring insert</li> <li>■ Max. temperature: 150 °C (300 °F)</li> <li>■ Material: aluminum, polyester powder coated</li> <li>Seals: Silicone</li> <li>■ Cable entry incl. glands: ½" NPT and M20x1.5, only thread: G ½", plugs: M12x1 PA, 7/8" FF</li> <li>■ Protection armature connection: M24x1.5</li> <li>■ Head color: blue RAL 5012</li> <li>■ Cap color: grey RAL 7035</li> <li>■ Weight: 420 g (14.81 oz)</li> <li>■ Head transmitter optional with TID10 display</li> </ul>

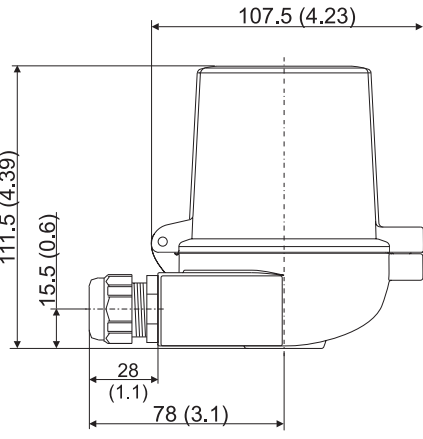
TA30D	Specification
 <p style="text-align: right; font-size: small;">a0009822</p>	<ul style="list-style-type: none"> <li>■ Degree of protection: IP66/68</li> <li>■ Tapped hole spacing: 33 mm (1.30") for the measuring insert</li> <li>■ Max. temperature: 150 °C (300 °F)</li> <li>■ Material: aluminum, polyester powder coated</li> <li>Seals: Silicone</li> <li>■ Cable entry incl. glands: ½" NPT and M20x1.5, only thread: G ½", plugs: M12x1 PA, 7/8" FF</li> <li>■ Protection armature connection: M24x1.5</li> <li>■ Two head transmitters can be mounted.</li> <li>■ Head color: blue RAL 5012</li> <li>■ Cap color: grey RAL 7035</li> <li>■ Weight: 390 g (13.75 oz)</li> </ul>

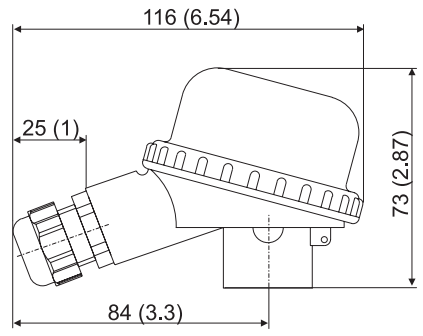
TA20B	Specification
 <p style="text-align: right; font-size: small;">a0008663</p>	<ul style="list-style-type: none"> <li>■ Degree of protection: IP65</li> <li>■ Tapped hole spacing: 33 mm (1.30") for the measuring insert</li> <li>■ Max. temperature: 80 °C (176 °F)</li> <li>■ Material: polyamide (PA)</li> <li>■ Cable entry: M20x1.5</li> <li>■ Head and cap color: black</li> <li>■ Weight: 80 g (2.82 oz)</li> <li>■ 3-A<sup>®</sup> certified</li> </ul>

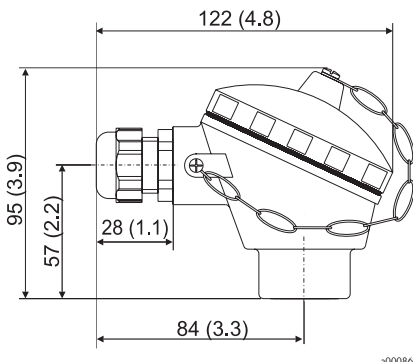
TA21E	Specification
 <p style="text-align: right; font-size: small;">a0008669</p>	<ul style="list-style-type: none"> <li>■ Degree of protection: IP65</li> <li>■ Tapped hole spacing: 33 mm (1.30") for the measuring insert</li> <li>■ Max. temperature: 130 °C (266 °F) silicone, 100 °C (212 °F) rubber (observe max. permitted temperature of the cable gland!)</li> <li>■ Material: aluminum alloy with polyester or epoxy coating; rubber or silicone seal under the cover</li> <li>■ Cable entry: M20x1.5 or plug M12x1 PA</li> <li>■ Protection armature connection: M24x1.5, G ½" or NPT ½"</li> <li>■ Head color: blue RAL 5012</li> <li>■ Cap color: grey RAL 7035</li> <li>■ Weight: 300 g (10.58 oz)</li> </ul>

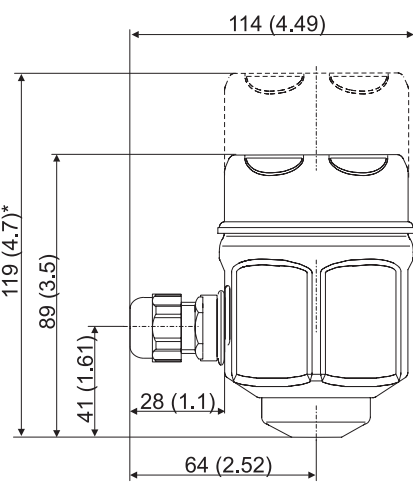
TA20J	Specification
 <p style="text-align: right; font-size: small;">a0008666</p> <p><i>* dimensions with optional display</i></p>	<ul style="list-style-type: none"> <li>■ Degree of protection: IP66/IP67</li> <li>■ Tapped hole spacing: 33 mm (1.30") for the measuring insert</li> <li>■ Material: 316L (1.4404) stainless steel, rubber seal under the cover (hygienic design)</li> <li>■ 4 digits 7-segments LC display (loop powered)</li> <li>■ Cable entry: ½" NPT, M20x1.5 or plug M12x1 PA</li> <li>■ Protection armature connection: M24x1.5 or ½" NPT</li> <li>■ Head and cap color: stainless steel, polished</li> <li>■ Weight: 650 g (22.93 oz) with display</li> <li>■ Humidity: 25 to 95%, no condensation</li> <li>■ 3-A<sup>®</sup> certified</li> </ul> <p>The programming is executed through 3 keys at the bottom of the display.</p>

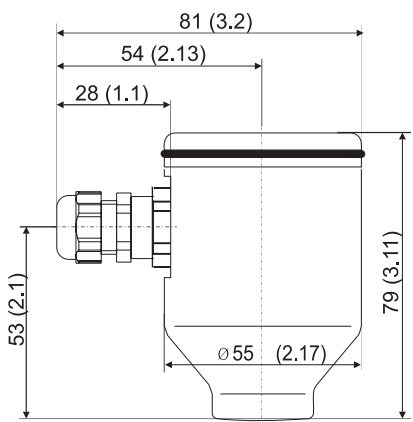
TA20R	Specification
 <p style="text-align: right; font-size: small;">a0008667</p>	<ul style="list-style-type: none"> <li>■ Degree of protection: IP66/67</li> <li>■ Tapped hole spacing: 33 mm (1.30") for the measuring insert</li> <li>■ Max. temperature: 100 °C (212 °F)</li> <li>■ Material: SS 316L (1.4404) stainless steel</li> <li>■ Cable entry: ½" NPT, M20x1.5 or plug M12x1 PA</li> <li>■ Head and cap color: stainless steel</li> <li>■ Weight: 550 g (19.4 oz)</li> <li>■ LABS - free</li> <li>■ 3-A<sup>®</sup> certified</li> </ul>



**Protection tube**

The starting material for the wetted parts can be supplied in compliance with the Basler Norm 2 (BN2), which imposes a limited ferrite content and consequently enhances corrosion resistance, on request. In some assembly configurations, the compliance with the requirements of BN2 can also be assured after the welding and machining operations, that is in the finished product.

The surface roughness (Ra) of the wetted parts is supplied down to 0.4 mm level. Surface roughness below 0.4-0.5 mm has not been proven to be advantageous in hygienic applications.

Electro-polishing is the electrolytic treatment of the metal surfaces, which results in cleaning, levelling and passivity.

In the TR47, it can be specified that a thermally conductive compound be applied inside the thermowell. This improves the heat transfer between the well and the internal sensing insert. The compound should not be used at temperatures higher than 200 °C.

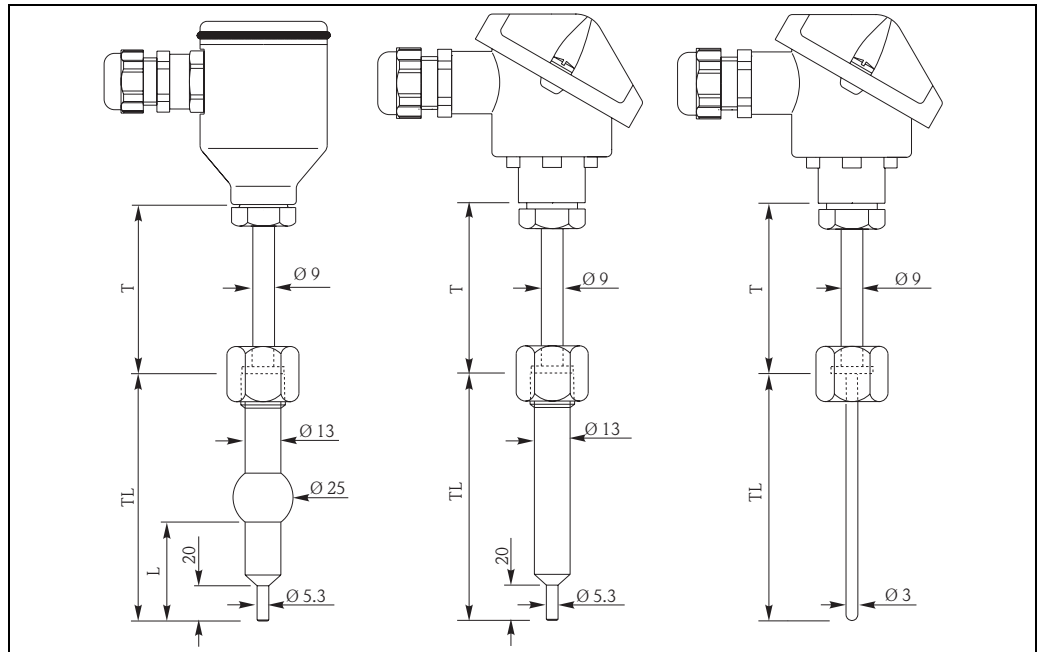

TR47 (spherical and cylindrical thermowell or without thermowell)

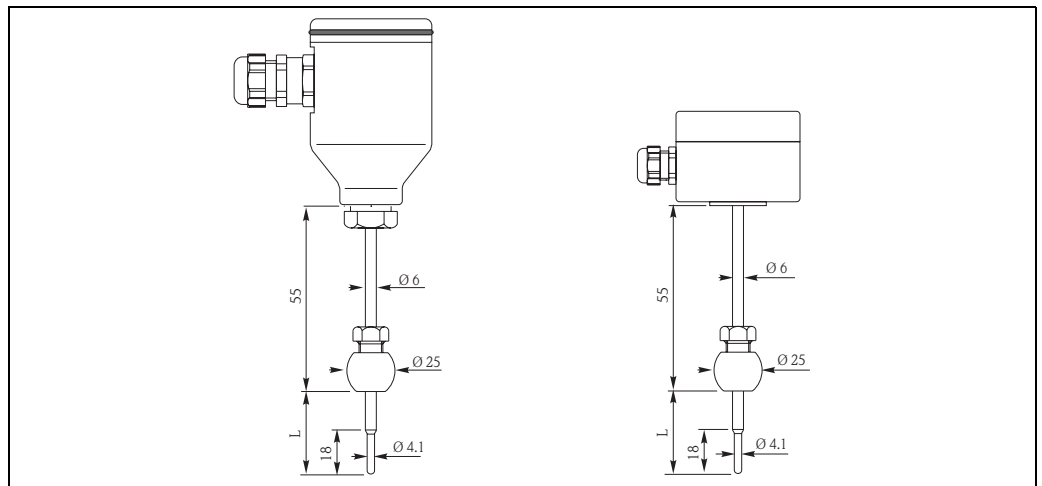

TR48 (e. g. housing in Stainless steel or in polyamide)

**Weight**

From 0.5 to 2.5 kg (1 to 5.5 lbs) for standard options.

**Extension neck**

In the TR47, the extension neck (part between the thermowell and the housing) is made of stainless steel, and threaded onto the adjacent components. The connection on the thermowell side is G 3/8".

In the TR48 the extension neck is an integral part of the probe stem and therefore its diameter is 6 mm. The upper connection of the neck permits adjustments to the orientation of the terminal head (except for TR48 with TA20L or PA housing).

**Process connection**

With regard to the TR47, when installing the assembly on the process, the welding can be executed directly on the side wall of the thermowell or on a spherical connection supplied already welded to the well. The TR48 is supplied with a spherical bushing, which must previously be welded onto the plant. The spherical connection contains a sealing ring (sleeve), which comes into contact with the process medium. The material (PTFE, Peek or stainless steel) used in the manufacture of the sleeve, complies with CFR Title 21, § 177.1550 or § 177.2415 (FDA). Please note that the spherical process connection utilised in the TR48, is different from the accessory TA56 and it is built in three different models.

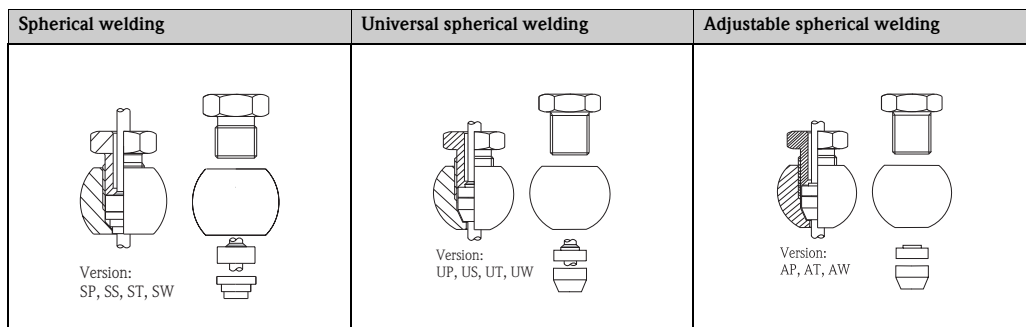

TR48 process connections

**Spare parts**

In the TR47 the measuring probe is made up of a mineral insulated insert positioned inside the thermowell. For its replacement, the insert length (IL) must be selected according to the length (TL+T) of the thermowell. When selecting a spare part, please refer to the following table:

Assembly	Immersion length	Insert	Insert diameter	Extension neck	Insert length (mm)
TR47	TL = 70 mm	TPR 100	3 mm	T = 50 mm	IL = 145
TR47	TL = 100 mm	TPR 100	3 mm	T = 35 mm	IL = 160
TR47	TL = 150 mm	TPR 100	3 mm	T = 40 mm	IL = 215
TR47	TL = 200 mm	TPR 100	3 mm	T = 50 mm	IL = 275
TR47	TL	TPR 100	3 mm	T	IL = TL + T + 26

In the TR48, the thermowell and the sensing part cannot be separated. The immersion length is available in some standard values or it can be selected "customized" within a range (please refer to the product structures at the end of this document).

## Wiring

**Wiring diagrams**

Type of sensor connection

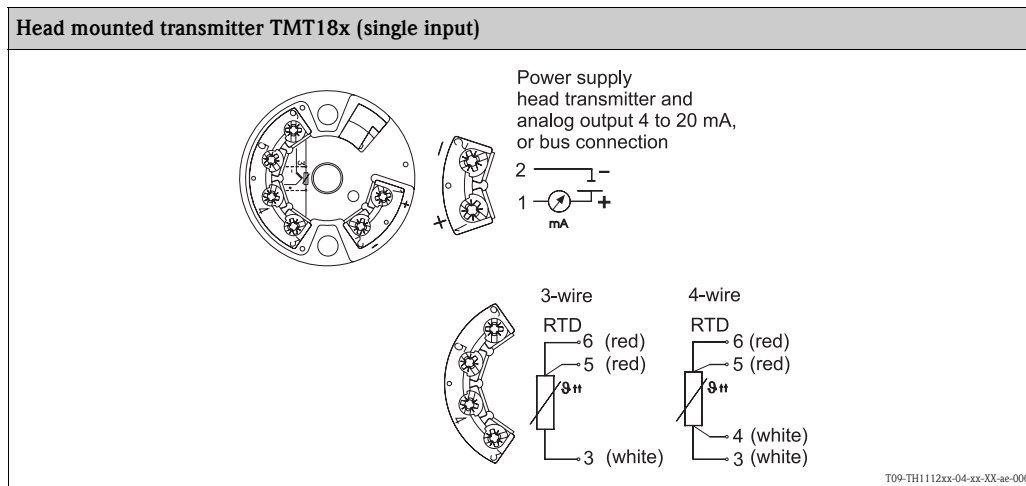

### Head mounted transmitter TMT84 and TMT85 (dual input)

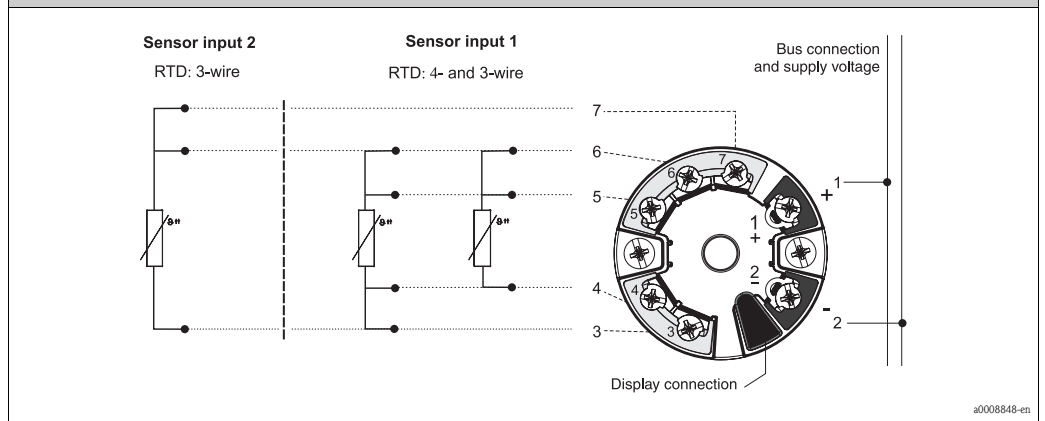

### Terminal block mounted

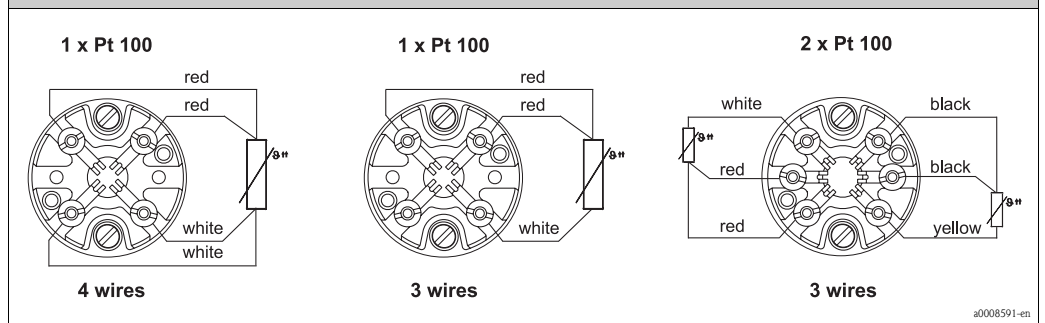

## Installation conditions

### Orientation

No restrictions.

### Installation instructions

Omnigrad M TR47 and TR48 can be mounted on the wall of pipes or vessels.

With regard to TR47, the thermowell must be welded on the plant along its cylindrical side wall or on an optional spherical connection that has already been welded on the well.

In the TR48, it is the spherical bushing which has to be welded on the pipe or vessel. Subsequently the threaded part of the connection must be tightened with a torque of 10 Nm.

Care should be taken by the user in the execution of the welding on the process side (suitable weld material, welding radius > 3.2 mm, absence of pits, folds, crevices, ...). As a general rule, the assemblies should be installed in such a way that does not adversely affect their cleanability (3-A<sup>®</sup> requirements must be adhered to). In the case of ATEX-certified components (transmitter, insert), please refer to the relevant documentation (code at the end of this document).

In both assemblies the immersion depth may have an effect on the accuracy of the measurement. If the immersion is too low, an error may be generated in the recorded temperature due to the lower temperatures of the process fluid near the walls and heat transfer, which takes place through the sensor stem. The incidence of such an error can be not negligible if there is a big difference between the process and the ambient temperature. To avoid this source of inaccuracy, the immersion length (L) should be, if possible, at least 80 mm. In pipes with a small diameter, the axis line of the duct must be reached, and even slightly exceeded, by the tip of the probe.

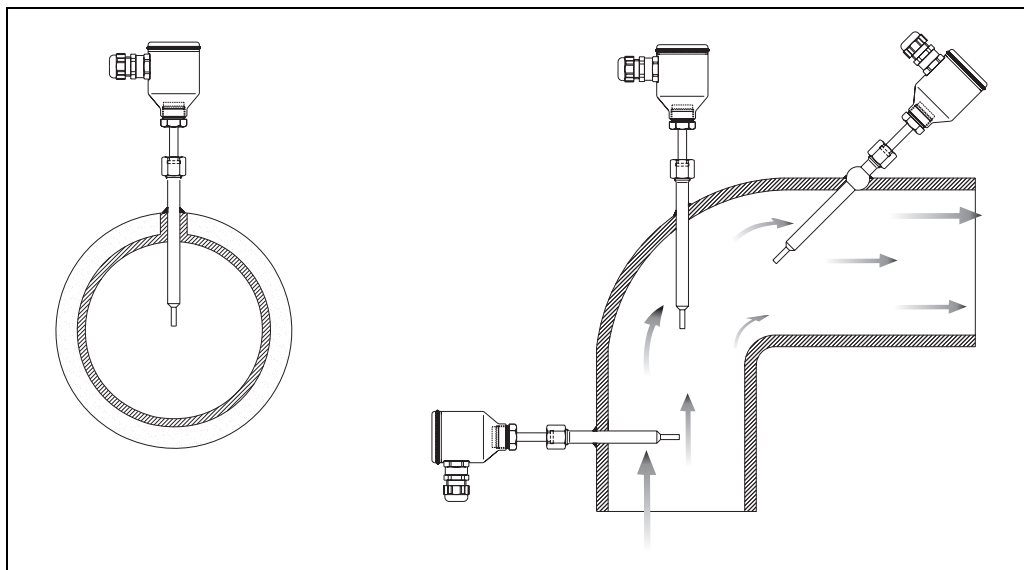

*General installation solutions for TR47*

Insulation on the outer part of the assembly reduces the effect of the low immersion. Another solution could be a tilted installation.

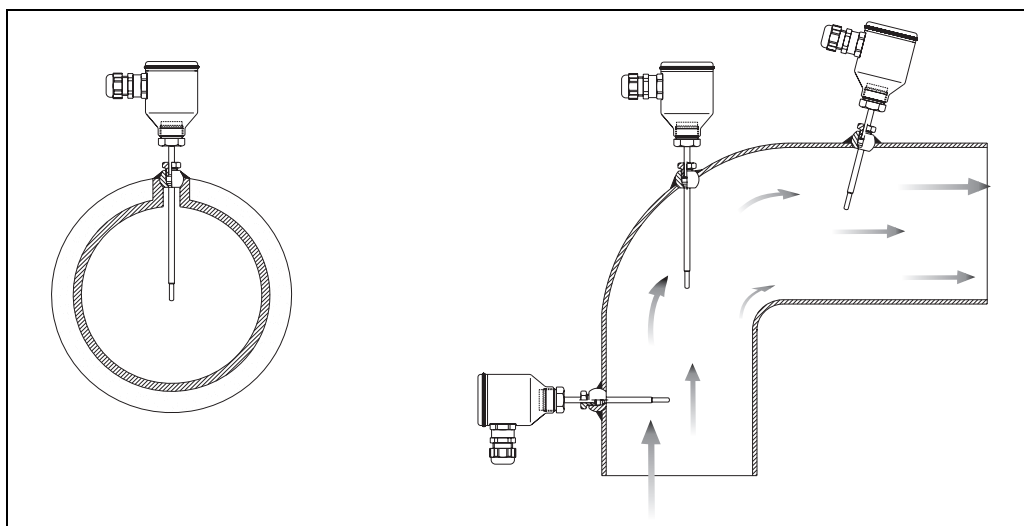



*General installation solutions for TR48*

Attention should be paid to the choice of measurement point in the case of two-phase flows since it may cause fluctuations in the detected temperature value.

With regard to corrosion, the base material of the wetted parts (SS 316L/1.4435) is capable of tolerating common corrosive media up to high temperatures. Besides the sleeves included in TR48 process connection are resistant to a wide variety of aggressive substances. For further information on specific applications, please contact the E+H Service Department.

When disassembling the assemblies, new gaskets equivalent to the originals and definite torques must be employed in the re-assembling procedure. This will ensure the stated IP (Ingress Protection) grade of the enclosures. When the ambient has a high humidity rate and the process is at low temperature, a plastic housing is recommended (i.e. model TA20B) to avoid problems due to condensation.

## Certificates and approvals

<b>CE Mark</b>	The device meets the legal requirements of the EC directives if applicable. Endress+Hauser confirms that the device has been successfully tested by applying the CE mark.
<b>Hazardous area approvals</b>	For further details on the available Ex versions (ATEX, CSA, FM, etc.), please contact your nearest Endress+Hauser sales organization. All relevant data for hazardous areas can be found in separate Ex documentation. If required, please request copies.
<b>Sanitary compatibility</b>	<p>Certifications from external bodies:</p> <ul style="list-style-type: none"> <li>■ 3-A<sup>®</sup> Authorization no. 1144 for the declaration of compliance with standard 74-03</li> <li>■ 3-A<sup>®</sup> accept the process connections, marked in the product structure of TR47 (→  14) and TR48 (→  16)</li> </ul>
<b>Other standards and guidelines</b>	<ul style="list-style-type: none"> <li>■ IEC 60529: Degrees of protection by housing (IP-Code).</li> <li>■ IEC 61010-1: Safety requirements for electrical measurement, control and laboratory instrumentation.</li> <li>■ IEC 60751: Industrial platinum resistance thermometer</li> <li>■ DIN43772: Protection tubes</li> <li>■ EN 50014/18, DIN 47229: Terminal heads</li> <li>■ IEC 61326-1: Electromagnetic compatibility (EMC requirements)</li> </ul>
<b>PED approval</b>	The thermometer complies with paragraph 3.3 of the Pressure Equipment Directive (97/23/CE) and is not marked separately.
<b>Material certification</b>	The material certificate 3.1 (according to standard EN 10204) can be directly selected from the sales structure of the product and refers to the parts of the sensor in contact with the process fluid. Other types of certificates related to materials can be requested separately. The "short form" certificate includes a simplified declaration with no enclosures of documents related to the materials used in the construction of the single sensor and guarantees the traceability of the materials through the identification number of the thermometer. The data related to the origin of the materials can subsequently be requested by the client if necessary.
<b>Test on protection tube</b>	Protection tube pressure tests are carried out in accordance with the specifications in the DIN 43772 standard. With regards to protection tubes with tapered or reduced tips that do not comply with this standard these are tested using the pressure of corresponding straight protection tubes. Sensors certified for use in Ex Zones, are always tested to pressures according to the same criteria. Tests according to other specifications can be carried out on request. Dye penetration tests verify the absence of cracks on the protection tube welding.
<b>Test report and calibration</b>	<p>With regards to the tests and calibration, the "Inspection Report" consists of a compliance declaration for the essential points of the standard IEC 60751.</p> <p>The "Factory calibration" is carried out in an EA (European Accreditation) authorized laboratory of Endress+Hauser according to an internal procedure. A calibration may be requested separately according to an EA accredited procedure (SIT calibration). Calibration is carried out on the thermometer insert.</p>

## Ordering information

### Product structure TR47

Weld-in thermometer with neck separated from thermowell, for use in food and pharma industry. Fast response time and high pressure resistance. Replaceable mineral insulated insert with Pt100. Wetted part built from same material. Temperature range: from -50 to 400°C.

Version:	
1	With thermowell
2	w/o thermowell (not 3A certified)
Total Lengths: TL; L; T:	
A	70 mm; 0mm cylindrical; 50mm, 3A
B	100 mm; 0mm cylindrical; 35mm, 3A
C	150 mm; 0mm cylindrical; 40mm, 3A
D	200 mm; 0mm cylindrical; 50mm, 3A
N	70 mm; 25mm spherical; 50mm, 3A
P	100 mm; 50mm spherical; 35mm, 3A
Q	150 mm; 100mm spherical; 40mm, 3A
R	200 mm; 150mm spherical; 50mm, 3A
S	85 mm; 25mm; G1/2" metal to metal
Y	..... mm, as specified
1	85 mm; 0mm cylindrical; 50mm, 3A
2	85 mm; 35mm spherical; 50mm, 3A
Tip shape:	
Q	Reduced + thermocond. paste
R	Reduced
Y	Special version, to be specified
0	Not needed
Material; Finishing:	
0	Not needed
1	316L, RA ≤ 0.8µm
3	316L, RA ≤ 0.4µm
4	316L, RA ≤ 0.4µm electro-polished
9	Special version
Terminal type:	
2	Flying leads
3	Terminal block
RTD; wire; meas. range; class; validity:	
H	1xPt100 TF; 3; -50/400 °C; A: -50/250 °C
L	2xPt100 WW; 3; -50/400 °C; A: -50/250 °C
M	1xPt100 TF; 4; -50/400 °C; A: -50/250 °C
P	1xPt100 TF; 3; -50/400 °C; 1/3B: 0/150 °C
Q	2xPt100 WW; 3; -50/400 °C; 1/3B: 0/150 °C
R	1xPt100 TF; 4; -50/400 °C; 1/3B: 0/150 °C
Y	Special version
Head; Cable Entry:	
A	TA20A Alu, IP66/IP67; M20
B	TA20B PA white, IP55; M20
E	TA21E Alu, screw cap IP65; M20
G	TA30A Alu, IP66/68; M20
H	TA30A Alu, IP66/67; M12 plug PA
I	TA30D Alu, high cover; G1/2" w/o gland
J	TA20J 316L, IP66/IP67; M20
K	TA20J 316L, display, IP66/IP67; M20
L	TA30A Alu, IP66/67; 7/8" plug FF
M	TA20J 316L, IP66/IP67; M12 plug PA
N	TA30A Alu +Display, IP66/68; M20
O	TA30A Alu +Display, IP66/67; M12 plug PA
P	TA30A Alu +Displ., IP66/67; 7/8" plug FF
Q	TA30A Alu +Display; G1/2" w/o gland
R	TA20R 316L screw cap IP66/IP67; M20
S	TA20R 316L screw cap IP66; M12 plug
T	TA30D Alu, high cover, IP66/68; M20
U	TA30D Alu, IP66/67; M12 plug PA
V	TA30D Alu, IP66/67; 7/8" plug FF
1	TA30A Alu; G1/2" w/o gland
2	TA20A Alu, IP66/IP67; NPT1/2
4	TA20A Alu, IP66; M12 plug PA



## Product structure TR48

Weld-in thermometer for use in food and pharma industry, with spherical fitting. Probe in direct contact with process-medium. Very fast response time and high pressure resistance. The temperature range depends on the sleeve. Temperature range: from -50 to 200 °C.

Process connection:	
<b>AP</b>	Universal spherical, sleeve PTFE, Locking screw M12x1.5, 3A
<b>AT</b>	TA56 adjustable, sleeve Teflon Locking screw M12x1.5, 3A
<b>AW</b>	TA56 not used, (not 3A certified)
<b>SP</b>	Spherical weld-in, sleeve stainless Locking screw G1/4", 3A
<b>SS</b>	Spherical welding conn., SS sleeve (locking screw G"1/4)
<b>ST</b>	Spherical weld-in, sleeve PTFE, 3A
<b>SW</b>	w/o weld-in spheric, Locking screw G1/4", (not 3A certified)
<b>UP</b>	Spherical universal, sleeve PEEK Locking screw M12x1.5, 3A
<b>US</b>	Spherical universal, sleeve stainless, Locking screw M12x1.5, 3A
<b>UT</b>	TA56 adjustable, sleeve PEEK Locking screw M12x1.5, 3A
<b>UW</b>	w/o universal spherical, Locking screw M12x1.5, (not 3A certified)
<b>YY</b>	Special version, to be specified
Immersion length L:	
<b>A</b>	20 mm
<b>B</b>	60 mm
<b>C</b>	100 mm
<b>Y</b>	..... mm, as specified
Material; Finishing:	
<b>0</b>	Not needed
<b>1</b>	316L, RA ≤ 0.8µm
<b>3</b>	316L, RA ≤ 0.4µm
<b>4</b>	316L, RA ≤ 0.4µm electro-polished
<b>9</b>	Special version
Terminal type:	
<b>2</b>	Flying leads
<b>3</b>	Terminal block
RTD; wire; meas. range; class: validity:	
<b>H</b>	1xPt100 TF; 3; -50/200 °C; A: -50/250 °C
<b>L</b>	2xPt100 WW; 3; -50/200 °C; A: -50/250 °C
<b>P</b>	1xPt100 TF; 3; -50/200 °C; 1/3B: 0/150 °C
<b>Y</b>	Special version
Head; Cable Entry:	
<b>A</b>	TA20A Alu, IP66/IP67; M20
<b>B</b>	TA20B PA white, IP55; M20
<b>E</b>	TA21E Alu, screw cap IP65; M20
<b>G</b>	TA30A Alu, IP66/68; M20
<b>H</b>	TA30A Alu, IP66/67; M12 plug PA
<b>I</b>	TA30D Alu, high cover; G1/2" w/o gland
<b>J</b>	TA20J 316L, IP66/IP67; M20
<b>K</b>	TA20J 316L, display, IP66/IP67; M20
<b>L</b>	TA30A Alu, IP66/67; 7/8" plug FF
<b>N</b>	TA30A Alu +Display, IP66/68; M20
<b>O</b>	TA30A Alu +Display, IP66/67; M12 plug PA
<b>P</b>	TA30A Alu +Displ., IP66/67; 7/8" plug FF
<b>R</b>	TA20R 316L screw cap IP66/IP67; M20
<b>S</b>	TA20R 316L screw cap IP66; M12 plug
<b>T</b>	TA30D Alu, high cover, IP66/68; M20
<b>U</b>	TA30D Alu, IP66/67; M12 plug PA
<b>V</b>	TA30D Alu, IP66/67; 7/8" plug FF
<b>1</b>	TA30A Alu; G1/2" w/o gland
<b>2</b>	TA20A Alu, IP66/IP67; NPT1/2
<b>4</b>	TA20A Alu, IP66; M12 plug PA
<b>7</b>	TA20B PA black, IP65; M20
Head transmitter; Range:	
<b>A</b>	TMT84-B1 PA ATEX
<b>B</b>	TMT84 PA
<b>D</b>	TMT85 FF
<b>E</b>	TMT85-B1 FF ATEX
<b>P</b>	TMT181 (PCP); temp. range to be specified, 2-wire, isolated
<b>Q</b>	TMT181-B PCP ATEX; temp. range to be specified, 2-wire, isolated
<b>R</b>	TMT182-A (HART, SIL2); temp. range to be specified, 2-wire, isolated
<b>T</b>	TMT182-B (HART, SIL2) ATEX; temp. range to be specified, 2-wire, isolated
<b>0</b>	Not needed





## Documentation

---

Technical information:

- RTD thermometers Omnigrad TST - General information (TI088T/02/en)
- Temperature head transmitter iTEMP<sup>®</sup>Pt TMT180 (TI088R/09/en)
- Temperature head transmitter iTEMP<sup>®</sup>PCP TMT181 (TI070R/09/en)
- Temperature head transmitter iTEMP<sup>®</sup>HART<sup>®</sup>TMT182 (TI078R/09/en)
- Temperature head transmitter iTEMP<sup>®</sup>TMT84 PA (TI138R/09/en)
- Temperature head transmitter iTEMP<sup>®</sup>TMT85 FF (TI134R/09/en)
- Pt100 insert - Omnigrad TET 105 (TI103T/02/en)
- Thermowell for temperature sensor - Omnigrad M TW47 (TI253T/02/en)
- Safety instructions for use in hazardous areas (XA003T/02/a3)

### Instruments International

Endress+Hauser  
Instruments International AG  
Kaegenstrasse 2  
4153 Reinach  
Switzerland

Tel. +41 61 715 81 00  
Fax +41 61 715 25 00  
[www.endress.com](http://www.endress.com)  
[info@ii.endress.com](mailto:info@ii.endress.com)

**Endress+Hauser**   
People for Process Automation