

BIOMASS BOILERS | STOVES



THERMASIS, as a part of BOYSIS GROUP, designs and produces biomass and solid fuel boilers for individual heating, with a team having more than 10 years of experience at European biomass boiler market. All of our production is exported to a wide area from East Europe to South American markets. Our headquarters is located in Istanbul, and production plant in one of industrial estates in Marmara region, near Balıkesir, Turkey.

A respectively wide range of products enables us to serve and cooperate in different parts in Europe. We take our power from flexibility at adapting our products in respect with customer and market demands.

The quality of products and management of our company are guaranteed by ISO 9001/2015 and Pressure Equipment Directive (2014/68/EU) certifications. The presence on many European markets are confirmed by relative European normatives for different product categories and locally issued certificates in accordance with standards of each country.

Our mission is to follow new technologies on design and production, expand our production and sales with good quality products and improve our service to our clients.

Our vision is to move THERMASIS brand to a well known level associated with quality and trust.



Wood Gasification Boilers

SOLARIS

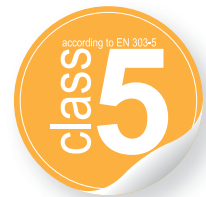

18 to 50 kW
Exhaust fan speed modulation
Flue thermostat
Large, dry fuel loading chamber
Self activated by-pass system

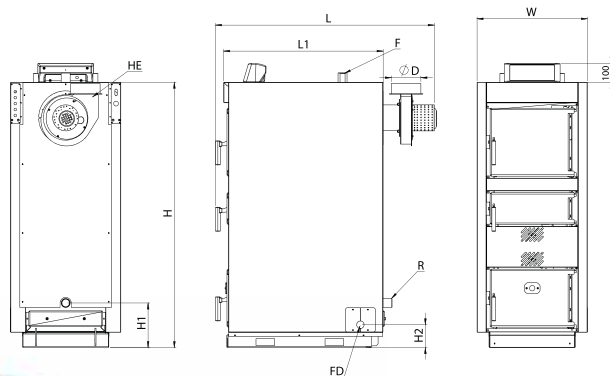

- Pyrolytic combustion, suitable for firing of dry wood logs
- Large and tall fuel loading chamber optimized for gasification process
- Dry fuel loading chamber by double wall, less condensation, higher gasification ratio, and easier surface cleaning
- Self activated by-pass system when loading door is opened
- Auto switch-off when there is no fuel
- Flue gas thermostat
- High efficiency due to smoke tubed water heating surfaces
- Integrated cooling loop for protection against over-heating
- Stylish electronic control board with well organized function buttons and big LCD screen
- Room thermostat connection

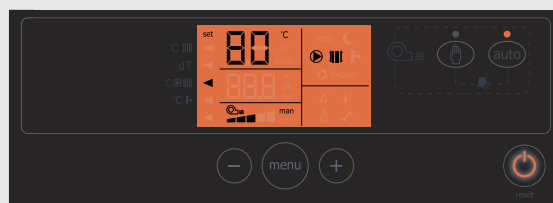

Model		SOLARIS					
Types		SLS 18	SLS 25	SLS 32	SLS 40	SLS 50	
Description of boiler		Welded steel boiler for dry wood logs, in pyrolytic combustion principle, with negative pressure in combustion chamber driven by exhaust fan at flue					
Fuels		Dry wood logs					
Output	kW	18	25	32	40	48	
Water content	lt	72	87	91	124	155	
Fuel container volume	dm ³	90,0	120,0	130,0	140,0	220,0	
Maximum wood log length	cm	50,0				60,0	
Flue gas temperature	°C	< 150					
Temperature control range	°C	65 - 90					
Maximum operating temperature	°C	100					
Minimum return temperature	°C	65 (recommended)					
Maximum operating pressure	bar	3					
Water flow/return connections (F/R)	R	1 1/2"					
Cooling loop connections (HE)	R	3/4"					
Filling / draining connection (FD)	R	1/2"					
External dimensions							
	H	mm	1325	1425	1475	1545	1545
	H1	mm	240				
	H2	mm	125				
	W	mm	545	595	595	595	695
	L1	mm	840	855	855	855	1050
	L	mm	1160	1175	1175	1175	1270
	D	mm	160				
Electrical supply		230 V / 50 Hz					
Power consumption		W	50				

Wood Gasification Boilers

SOLARIS LX

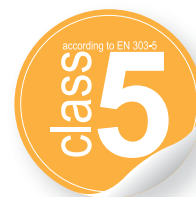

Lambda sonda
Primary and secondary air regulation
Exhaust fan speed modulation
Flue thermostat
Auto smoke pipe cleaning
Self activated by-pass system

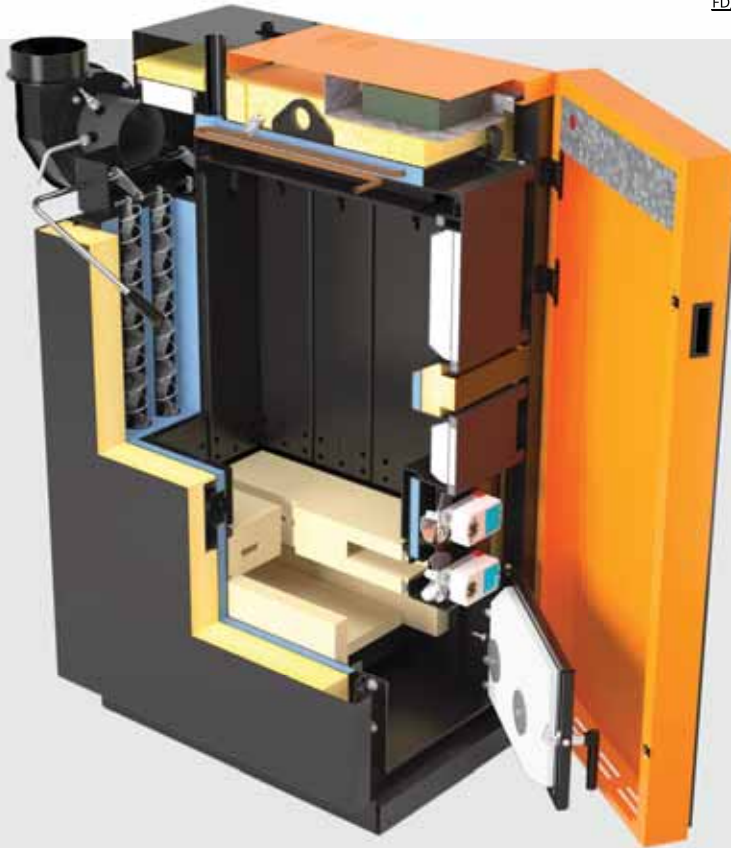
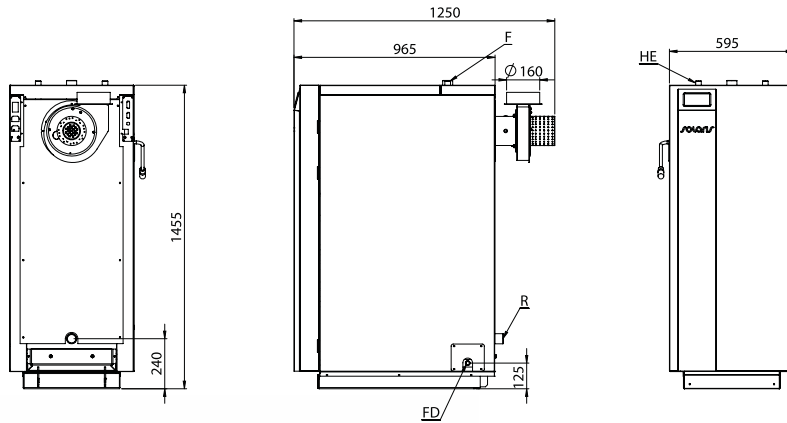

- PID control
- Lambda sonda
- Primary and secondary air regulation
- 92% water efficiency
- Large and tall fuel loading chamber optimized for gasification process
- Dry fuel loading chamber by double wall, less condensation, higher gasification ratio, and easier surface cleaning
- Self activated by-pass system when loading door is opened
- Auto smoke pipe cleaning system
- Auto switch-off when there is no fuel
- Flue gas thermostat
- High efficiency due to smoke tubed water heating surfaces
- Integrated cooling loop for protection against over-heating
- Chrono management

Model		SLS 25 LX
Fuels		Dry wood logs
Output	kW	25
Water content	lt	87
Total heating surface	m ²	3,10
Fuel container volume	dm ³	120
Maximum wood log length	cm	50
Fuel loading clearance (H x W)	mm	280x370
Flue gas temperature	C	< 125
Required draft at chimney (min-max)	Pa	8 - 12
	mbar	0,08 - 0,12
Temperature control range	C	60 - 90
Maximum operating temperature	C	100
Minimum return temperature	C	55 (recommended)
Safety system activated at	C	95
Maximum operating pressure	bar	3
Water flow/return connections (F/R)	R	1 1/2"
Cooling loop connections (HE)	R	3/4"
Filling / draining connection (FD)	R	1/2"
Electrical supply		230 V / 50 Hz
Power consumption	W	60

Wood Gasification Boilers

OPTIMUS



15 to 80 kW
Exhaust fan speed modulation
Electronic control
Manual by-pass

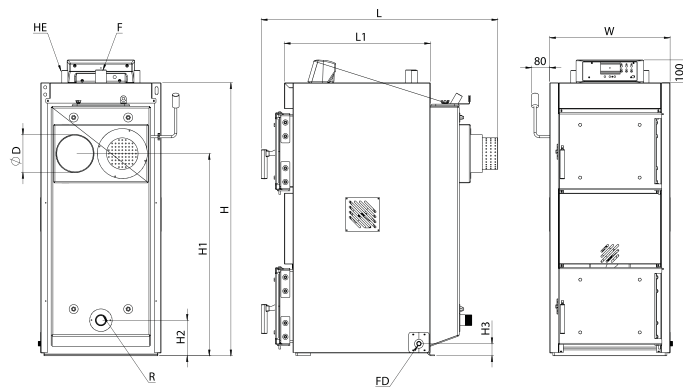

- Medium efficiency solutions for gasification boilers
- Pyrolytic combustion, suitable for firing dry wood logs
- Large and prismatic fuel loading particularly sized for better gasification process
- Manually activated by-pass mechanism
- High efficiency due to increased effective water cooled heating surface after combustion
- Integrated cooling loop for protection against over-heating
- Stylish electronic control board with well organized function buttons and LCD
- Auto switch-off when there is no fuel
- Room thermostat connection

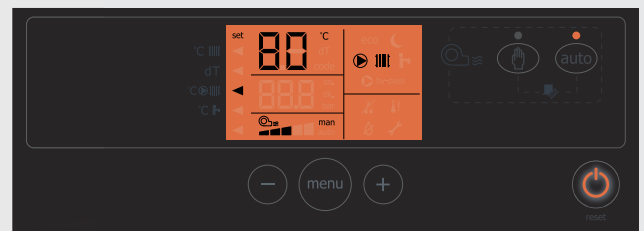

Model		OPTIMUS							
Types		OTS 15	OTS 22	OTS 30	OTS 38	OTS 48	OTS 60	OTS 80	
Description of boiler		Welded steel boiler for dry wood logs, in pyrolytic combustion principle, with negative pressure in combustion chamber driven by exhaust fan at flue							
Fuels		Dry wood logs							
Output	kW	15	22	30	38	48	60	80	
Efficiency	%	81 - 83							
Flue gas temperature	C	135 - 175							
Flue gas mass flow	g/s	15,0	21,0	28,5	36,0	45,5	57,0	75,5	
Water content	lt	60	74	85	97	114	138	161	
Maximum wood log length	cm	50,0	50,0	50,0	60,0	70,0	70,0	80,0	
Fuel loading chamber volume	dm ³	73	83,0	108,0	120,0	165,0	202,0	277,0	
Fuel loading clearance (upper door)	cm ²	905	1195	1195	1315	1315	1660	1660	
Temperature control range	C	65 - 90							
Maximum operating temperature	C	100							
Minimum return temperature	C	65 (recommended)							
Safety system activated at	C	95							
Maximum operating pressure	bar	3							
Water flow/return connections (F/R)	R	1 1/2"					2"		
Cooling loop connections (HE)	R	3/4"							
Filling / draining connection (FD)	R	1/2"							
External dimensions									
	H	mm	1060	1090	1210	1210	1290	1290	1390
	H1	mm	560	780	900	900	980	980	1080
	H2	mm	190	160	160	160	160	160	160
	H3	mm	55	55	55	55	55	55	55
	W	mm	475	535	535	535	535	615	615
	L1	mm	648	648	648	748	848	848	958
	L	mm	1050	1050	1050	1170	1270	1270	1420
	D	mm	168					180	
Electrical supply		230 V / 50 Hz							
Power consumption		W	70				110		

Pellet Boilers

CORTINA



12 to 40 kW
Automatic ignition
Compact dimensions
Flexible built with a variety
of configurations

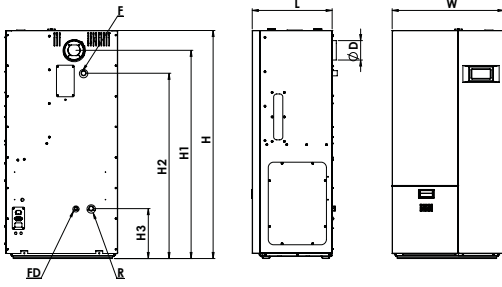

FEATURES	CORTINA S	CORTINA X	CORTINA Xpack
Electronic ignition	YES	YES	YES
PID control	YES	YES	YES
Fan modulation	YES	YES	YES
Fan operation (encoder)	YES	YES	YES
Burner cleaning	MANUAL	AUTOMATIC	AUTOMATIC
Smoke tube cleaning	MANUAL	AUTOMATIC	AUTOMATIC
Fire protection	YES	YES	YES
Flue thermostat	YES	YES	YES



OUTPUTS			
CHP and buffer tank	YES	YES	YES
DHWP and 3-way valve	NO	YES	YES
ACCESSORIES			
Central heating pump	N / A	N / A	YES
Expansion tank	N / A	N / A	YES
Pressure switch	N / A	N / A	YES
Safety valve	N / A	N / A	YES



- Automatic ignition
- PID control, adjustable boiler outputs
- Fire protection system, safety against back burning
- Exhaust fan speed modulation by outlet water temperature and flue gas temperature
- Vertical flue circulation principle
- High grade stainless steel burning pot
- Pellet level monitoring window
- Additional fuel tonk option with level sensor and second feeding screw

Model		CORTINA				
Types		CT 12	CT 18	CT 24	CT 32	CT 40
Fuel specifications		Wood pellets size 6 mm to EN 14961				
Maximum power output	kW	15	20	26	34	45
Minimum power output	kW	4,5	5,7	7,8	10,2	13,5
Efficiency at max output	%	91,2	88,8	89	89,1	89,3
Efficiency at min output	%	89,3	88,9	89,2	88,4	89,5
Flue gas temperature at max power	C	116	119	125	124	113
Flue gas temperature at min power	C	84	73	80	90	79
Water content	lt	44	40	45	70	76
Fuel container capacity	kg	50		58	90	100
	lt	88		106	162	190
Minimum return temperature	C	40 (With non-condensing working conditions)				
Flue gas mass flow Qmax	g/s	13	16	21	25	30
Flue gas mass flow Qmin	g/s	6	7	9	10	12
Required draft at chimney	Pa	8	10		12-15	
Temperature control range	C	45- 80				
Max operating temperature	C	80				
Max operating pressure	bar	3				
Water flow/return (F / R)	DD DG	1 " (male)				
Filling/draining connection (FD)	R	½ " (male)				
External dimensions						
H	mm	1365		1490	1620	1670
H1	mm	1195	1235	1360	1490	1540
H2	mm	1050	1085	1210	1340	1390
H3	mm	300	325		360	
W	mm	730			850	900
L	mm	525			575	625
D	mm	80				
Electrical supply		230V / 50Hz				
Power consumption (fan+feeder motor)	W	75				71
Power consumption (ignitor)	W	165				
Airborne noise (run mode)	dB	45-55				

Pellet boiler accessories

Additional fuel tank for Cortina



- Available for Cortina 12X, 18X and 24X
- Designed particularly to match boiler external dimensions, and ensure longer operation time without refuelling
- 250 liters additional fuel volume
- Pellet level sensor ensures auto refuelling when boiler original fuel container is empty
- Together with boiler's original tank, system can work up to 10 days without refuelling
- Additional tank is purchased separately, and can be added later to the boiler in operation.
- Pack of additional tank includes;
 - Fuel tank
 - Feeding screw
 - Gearmotor
 - Pellet level sensor
 - Adaptor to boiler tank
 - Wiring
 - Flexible feeding hose

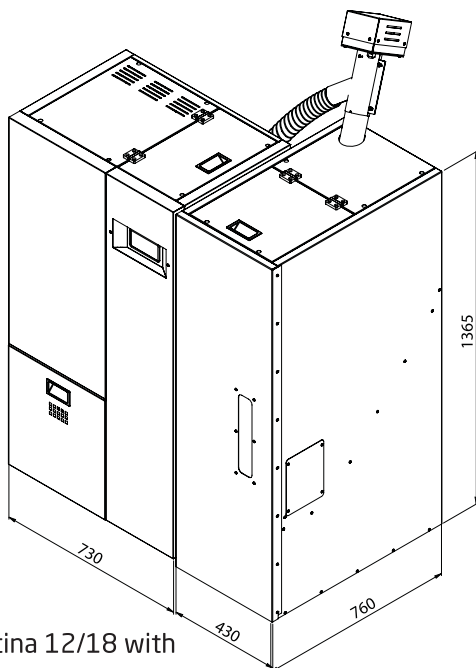

Cortina 12/18 with additional tank

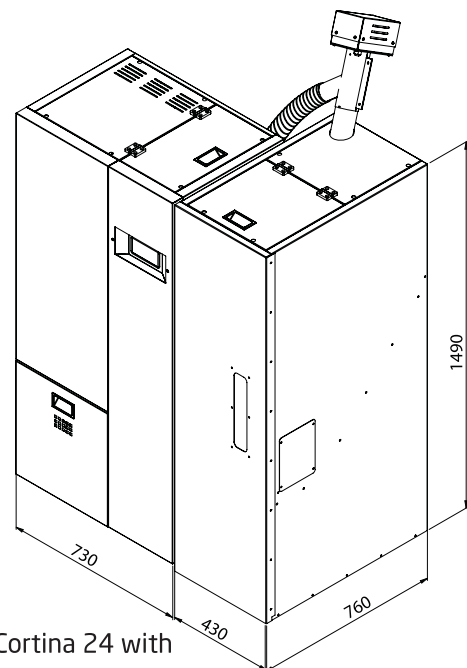

Cortina 24 with additional tank

Pellet Boilers

CARINA



12 and 20 kW
Three-pass flue circulation
Automatic ignition
Automatic brazier cleaning
Automatic smoke pipe cleaning
Fuel level detector
Automatic ash removal



- Automatic ignition
- PID control, adjustable boiler outputs
- Vertical three pass flue circulation principle with tubed heat exchanger ensures high efficiency
- Integrated high capacity fuel container
- Fire protection system, safety against back burning
- Exhaust fan speed modulation through outlet water temperature and flue gas temperature
- Air pressure switch ensures safety at the flue
- High grade stainless steel burning pot
- Auto pellet level detection and warning
- Automatic burner brazier cleaning
- Automatic smoke pipe cleaning
- Automatic ash removal (RX models)
- Touch button user display (X models)
- Touch screen user display (RX models)
- Chrono management
- Option for room sealed combustion air supply

FEATURES	CARINA X	CARINA RX
		
Electronic ignition	YES	YES
PID control	YES	YES
Fan modulation	YES	YES
Fan operation (encoder)	YES	YES
User display	Touch button	Touch screen
Auto pellet level detection	YES	YES
Auto brazier cleaning	YES	YES
Auto pipe cleaning	YES	YES
Auto ash removal	NO	YES
Fire protection	YES	YES
Flue thermostat	YES	YES
Chrono management	YES	YES
Outdoor temp. sensor	OPT	OPT
OUTPUTS		
CHP and buffer tank	YES	YES
DHWP and 3-way valve	YES	YES

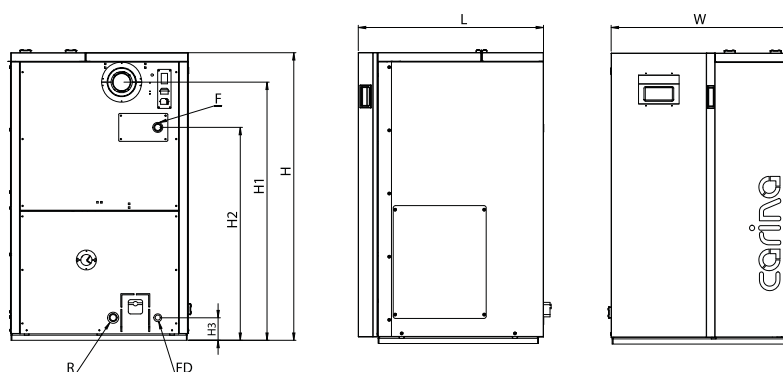



Models	CARINA 12	CARINA 20	
Description of boiler	Automatic feeding pellet boilers with fan at flue, working under negative pressure in chamber		
Fuel specifications	Wood pellets size 6-8 mm to EN 14961-2 Class A1		
Maximum power output	kW	12	
Minimum power output	kW	3,6	
Efficiency at max output	%	91,5	
Efficiency at min output	%	92,5	
Flue gas temperature at max power	C	105	
Flue gas temperature at min power	C	75	
Fuel container capacity	kg	80	
	lt	130	
Ash container capacity	lt	15 (only RX models)	
Flue gas mass flow Qmax	g/s	12	
Flue gas mass flow Qmin	g/s	5,5	
Required draft at chimney	Pa	10	
Temperature control range	C	45- 80	
Max operating temperature	C	80	
Max operating pressure	bar	3	
Water flow/return (F / R)	R	1 " (male)	
Filling/draining connection (FD)	R	½ " (male)	
Burner design		Stainless steel pot	
External dimensions	H	mm	1290
	H1	mm	1160
	H2	mm	955
	H3	mm	100
	W	mm	795
	L	mm	760
		mm	820
		mm	Ø 80
		mm	Ø 50
Electrical supply		230V / 50Hz	
Maximum power rating	W	411	
Power rating at work	W	131	

Pellet boiler accessories

Wi-fi module for pellet boilers

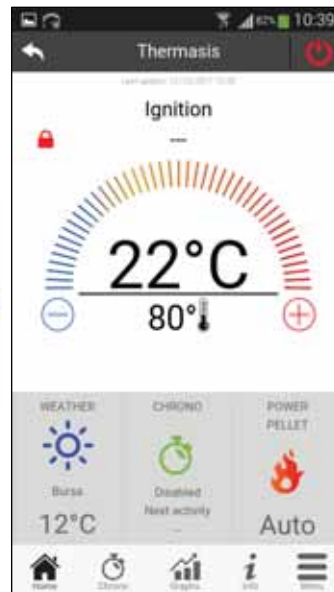

- Thermais 4HEAT wi-fi module can control all Cortina and Carina pellet boilers via smart phones or tablets (IOS and Android)
- Wi-fi module can also be added to a boiler system, which is already installed
- It only needs stable wi-fi network or ethernet connection.
- User can:
 - Read temperatures (boiler, exhaust and buffer)
 - Read status of boiler (OFF, Ignition, Stabilization, Run Mode, Blocks etc.)
 - Can see graphics of temperatures
 - Can see weather temperature (internet resources)
 - Set boiler temperature
 - Set boiler power
 - Manage chrono thermostat
- Technologies:
 - Wireless
 - IoT (Internet of Things)
 - Connection Home Automation Systems (With Nest, mumit BEVEL, Tado and Netatmo smart devices)
 - Cloud Connection

Air pellet stoves

ASTRA



6 and 8 kW
Automatic ignition
Glass cleaning system
Forced ventilation
Room air sealed combustion

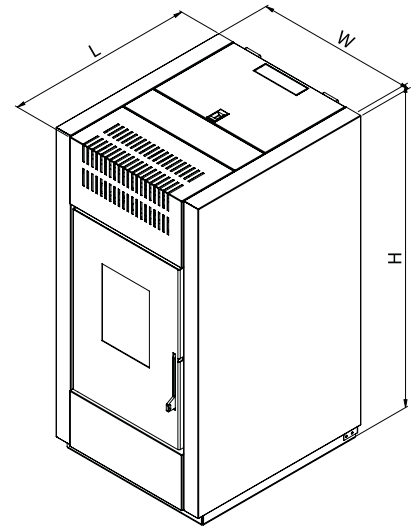
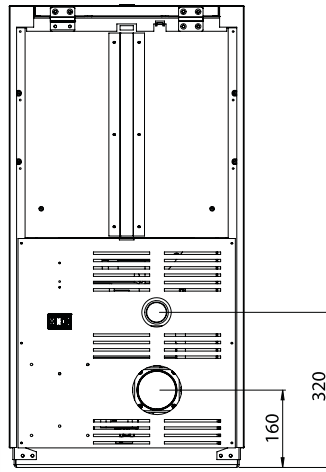
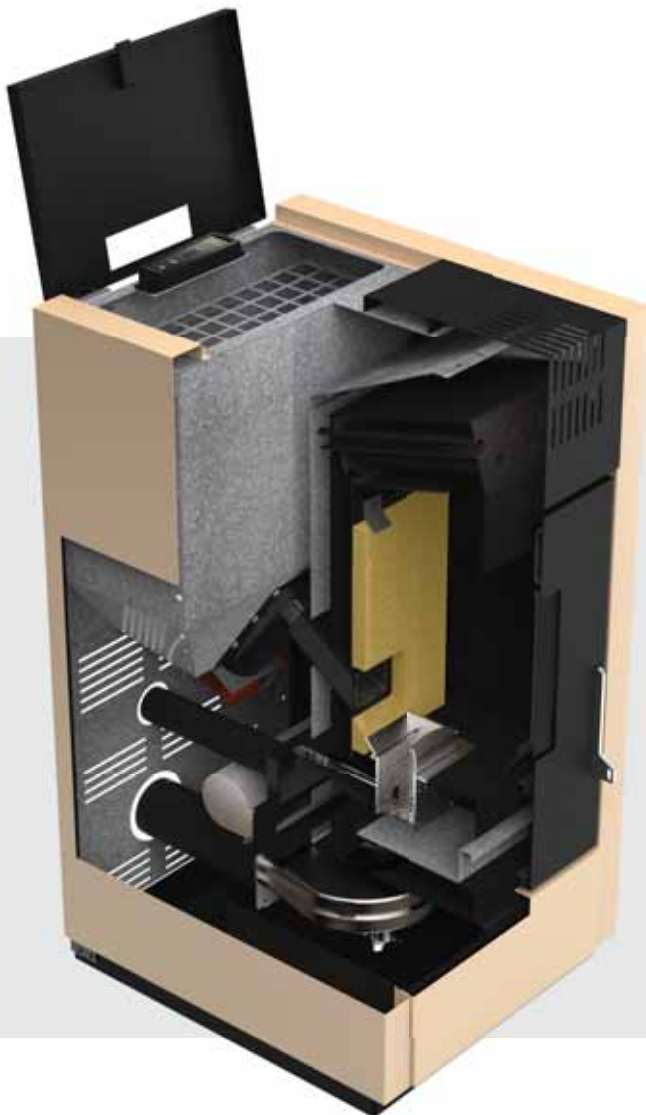

- Automatic ignition; PID control; output regulation
- Room sealed combustion ensures high safety
- High efficiency due to tube integrated and fully cooled heat exchanger
- Safety against back burning
- Air pressure switch for flue safety
- Exhaust fan speed modulation with encoder
- Burning pot made of special stainless steel
- Heat resistant ceramic glass
- Auto glass cleaning system
- Manually activated cleaning system in smoke passages
- Auto switch-off when there is no fuel
- Forced ventillation by a additional tangential fan
- Easy cleaning
- High volume for fuel and ash containers

Model		ASTRA 6	ASTRA 8
Thermal power (min/max)	kW	3,2 / 6,5	3,6 / 8
Hourly fuel consumption (min/max)	kg/h	0,68 / 1,36	0,64 / 1,70
Efficiency (min - max)	%	91 - 93	90,5 - 92,5
CO content (with 13% O2) min/max	%	0,02 / 0,013	0,02 / 0,013
Flue temperature (min/max)	°C	85 / 130	92 / 140
Minimum draught	Pa	10	
Autonomy (min - max)	h	16 - 30	14 - 32
Maximum power rating	W	394	
Power rating at work	W	114	
Supply voltage and frequency	V/Hz	230/50	
Fuel tank capacity	kg	22	23,5
	lt	37	40
Weight	kg	86	90
External dimensions	H	mm	895
	W	mm	480
	L	mm	555
Flue outlet diameter	mm	Ø 80	
Fresh air intake diameter	mm	Ø 50	

Hydro-pellet stoves

HYDRA / VEGA



HYDRA



VEGA

12 to 24 kW
Automatic ignition
Glass cleaning system
Packed with all hydraulic circuit

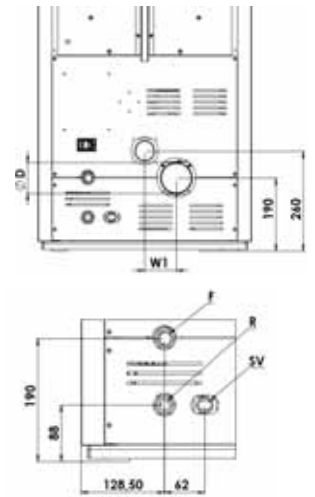
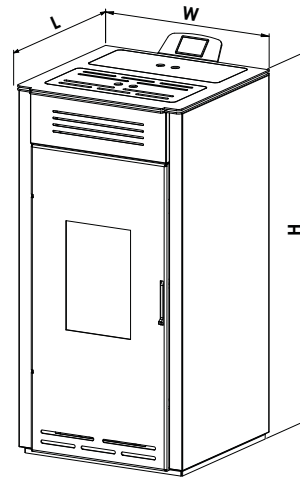

- Automatic ignition; PID control; output regulation
- Safety against back burning
- Completed hydraulic system with integrated circulation pump, expansion tank, and safety accessories
- Exhaust fan speed modulation
- Burning pot made of special stainless steel
- Heat resistant ceramic glass
- Auto glass cleaning system
- Manually activated cleaning system in smoke pipes
- Digital monitoring of system pressure
- Auto switch-off when there is no fuel

Model		HYDRA / VEGA		
Types		12	16	24
Thermal power (min/max)	kW	5 / 12	6,7 / 16	10 / 24
Thermal power of fluid (water) (min/max)	kW	4,1 / 9,7	5,4 / 12,9	8,1 / 19,4
Hourly fuel consumption (min/max)	kg/h	1,1 / 2,6	1,5 / 3,6	2,3 / 5,4
Efficiency	%	89	90	90
CO content (with 13% O2) min/max	%	0,02 / 0,0025	0,02 / 0,0025	0,02 / 0,003
Flue temperature (min/max)	°C	125 / 180	110 / 170	85 / 140
Minimum draught	Pa	10		
Maximum power rating	W	400		
Power rating at work	W	160		
Supply voltage and frequency	V/Hz	230/50		
Fuel tank capacity	kg	27	32	36
Expansion tank capacity	lt	7		
Maximum working pressure	bar	3		
Flow / Return (F / R)	R	3/4"		
Safety valve (SV)	R	3/4"		
External dimensions				
	H	mm	990	1060
	W	mm	560	
	W1	mm	80	110
	L	mm	540	
	D	mm	Ø 80	
	Fresh air intake diameter	mm	Ø 50	

Hydro-pellet stoves

HYDRA PLUS

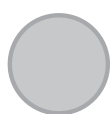

Aluminum

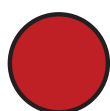

Wine red

12 and 16 kW
Automatic ignition
Glass cleaning system
Packed with all hydraulic circuit
Double glass layer in front

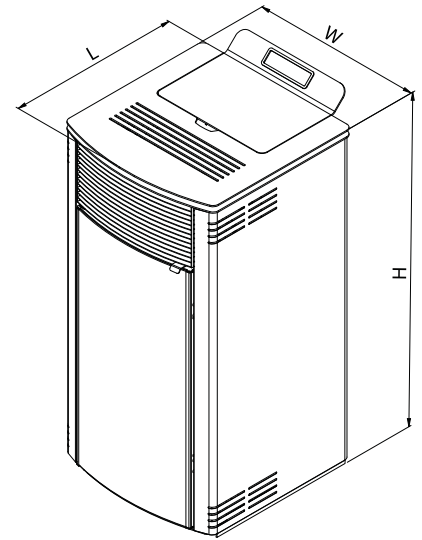
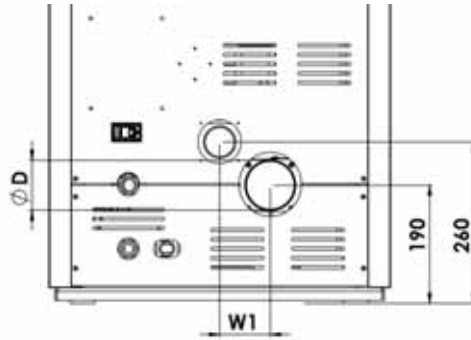
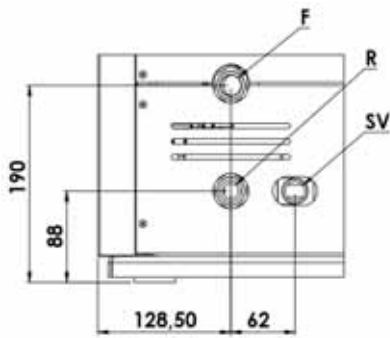

- Automatic ignition; PID control; output regulation
- Safety against back burning
- Completed hydraulic system with integrated circulation pump, expansion tank, and safety accessories
- Exhaust fan speed modulation
- Burning pot made of special stainless steel
- Double glass layer in front;
 - Internal fire door with heat resistant ceramic glass
 - External stylish tempered glass door with flame inspection clearance
- Auto glass cleaning system
- Manually activated cleaning system in smoke pipes
- Digital monitoring of system pressure
- Auto switch-off when there is no fuel

Models		Hydra Plus 12	Hydra Plus 16
Thermal power (min/max)	kW	5 / 12	6,7 / 16
Thermal power of fluid (water) (min/max)	kW	4,1 / 9,7	5,4 / 12,9
Hourly fuel consumption (min/max)	kg/h	1,1 / 2,6	1,5 / 3,6
Efficiency	%	92	92
CO content (with 13% O2) min/max	%	0,02 / 0,0025	0,02 / 0,0025
Flue temperature (min/max)	°C	105 / 130	100 / 125
Minimum draught	Pa	10	
Maximum power rating	W	400	
Power rating at work	W	160	
Supply voltage and frequency	V/Hz	230/50	
Fuel tank capacity	kg	27	32
Expansion tank capacity	lt	7	
Maximum working pressure	bar	3	
Flow / Return (F / R)	R	3/4"	
Safety valve (SV)	R	3/4"	
External dimensions			
	H	mm	1020
	W	mm	560
	L	mm	565
	D	mm	Ø 80
Fresh air intake diameter	mm	Ø 50	

Steel Boilers/ Natural Draught

ECO-BURN



20 to 75 kW
Three pass flue circulation
Universal pellet burner adaptor
Manual loading

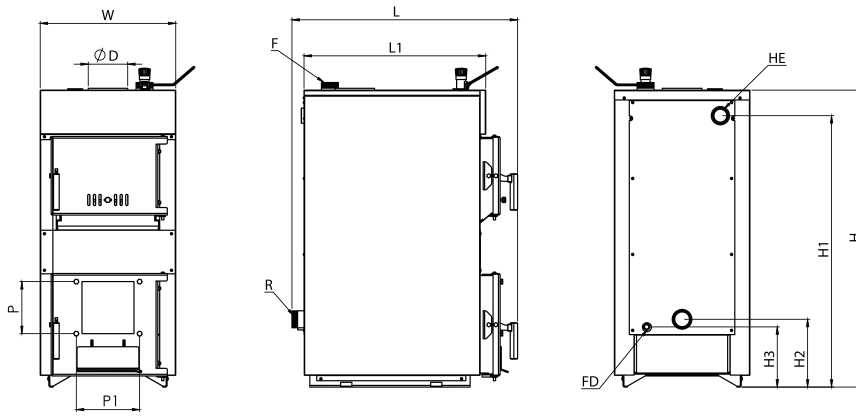

- Compact and efficient solution for manually loaded boilers
- Suitable for firing wood logs, brown coal, and lignite
- Manual adjustment on secondary air
- Easy loading due smoke damper behind loading door
- Cast iron bottom grate
- Scaled thermometer to monitor boiler outlet temperature
- Optional cooling loop for protection against over-heating

Model		ECO-BURN					
Types		EC 20	EC 28	EC 35	EC 45	EC 60	EC 75
Description of boiler		Manually stocked, welded steel boilers, for solid fuels in 3pass flue circulation principle					
Output (wood, hard coal, lignite)	kW	20	28	35	45	60	75
Water content	lt	56	64	74	84	104	118
Combustion chamber dimensions							
Height	mm	490				505	
Width	mm	330		420		480	
Length	mm	360	500		600		740
Maximum fuel loading height	mm	400					
Temperature control range	C	50 - 90					
Maximum operating temperature	C	100					
Minimum return temperature	C	50 (recommended)					
Safety system activated at	C	95					
Maximum operating pressure	bar	2,5					
Flow/return connections (F/R)	R	2 "					
Connection for cooling loop (HE)	R	1 1/2"					
Filling / draining connection (FD)	R	1/2"					
External dimensions							
H	mm	1060				1150	
H1	mm	970				1070	
H2	mm	230					
H3	mm	215					
W	mm	482		572		632	
L	mm	662	802		902		1042
L1	mm	506	646		746		886
Flue outlet (D)	mm	140		160		180	
Matchnig pellet burners							
Pellet burner assembly dimensions	P	185		185		185	
Pellet burner assembly dimensions	P1	225		225		165	
Max burner head size	mm	180 x 180		180 x 180		180 x 225	
Max burner tube length	mm	240		320		370	

Steel Boilers/ Fan Assisted ECO-BURN F



28 to 125 kW
Four pass flue circulation
Fan speed modulation
Electronic control
Manual loading

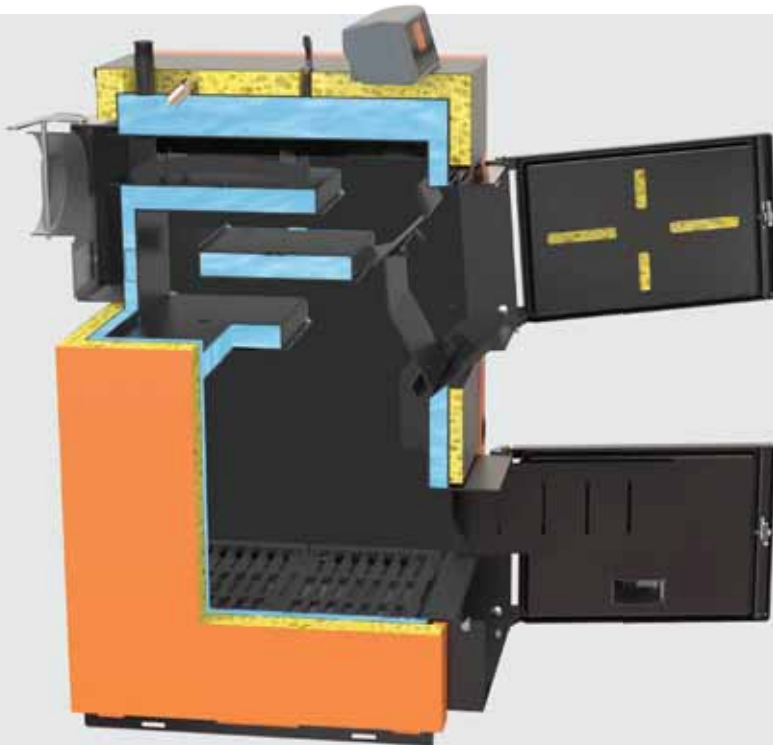
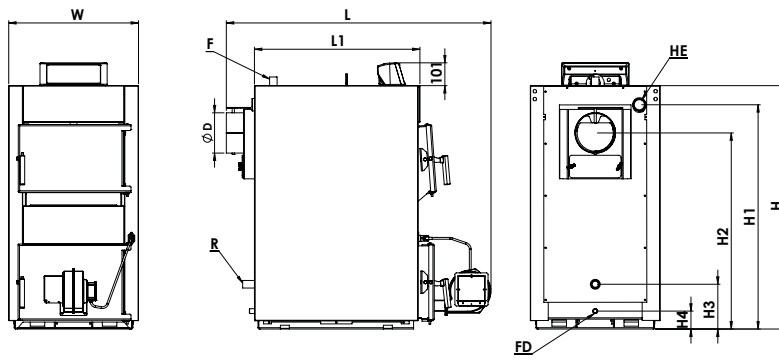

- Suitable for firing wood logs, brown coal, and lignite
- Cast iron bottom grade
- Optional cooling loop for protection against over-heating
- Fan assisted combustion with modulation on motor speed
- Stylish electronic board, energy saving, and safety features
- Auto switch-off when there is no fuel
- No air flow to the chamber, when fan is off
- Room thermostat and pellet burner integration

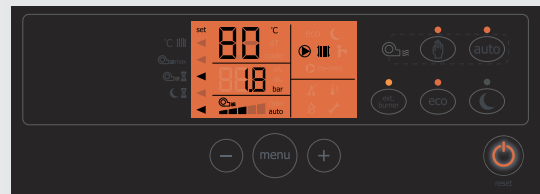

Model		ECO-BURN F						
Types		EF 28	EF 35	EF 45	EF 60	EF 75	EF 100	EF 125
Description of boiler		Manually stocked, welded steel boilers, for solid fuels in 4pass flue circulation principle, (fanned flue)						
Output (wood, hard coal, lignite)	kW	28	35	45	60	75	100	125
Water content	lit	70	80	90	110	126	175	220
Combustion chamber dimensions								
Height	mm	475					550	
	mm	330	420		480		550	
	mm	500		600		740	725	825
Fuel loading clearance	mmxmm	330 x 215	420 x 250		480 X 305		550 x 305	
Maximum fuel loading height	mm	400						
Flue circulation principle		Horizontal 4-pass					5-pass	
Control		Electronic with additional mechanical safety limiter						
Temperature control range	C	50 - 90						
Maximum operating temperature	C	100						
Minimum return temperature	C	50 (recommended)						
Safety system activated at	C	95						
Maximum operating pressure	bar	2,5					3	
Flow/return connections (F/R)	R	1"			1 1/4"		1 1/2"	
Connection for cooling loop (HE)	R	1 1/2"					2"	
Filling / draining connection (FD)	R	1/2"					3/4"	
External dimensions								
H	mm	1090			1180		1400	
	mm	1000			1105		1300	
	mm	875			980		1180	
	mm	200					335	
H4	mm	80						
	mm	310						
W	mm	490	580		640		750	
	mm	1082		1182	1192	1310	1525	1650
L1	mm	640		740	740	880	840	960
	mm	160	180					200
Electrical supply		232 V - 50 Hz						
Power consumption	W	82			88		200	

Cast Iron Boiler

LOGAN



with pellets

14 to 90 kW
Three pass flue circulation
High loading capacity
Universal pellet burner adaptor
Optional pellet door
Chimney flap control

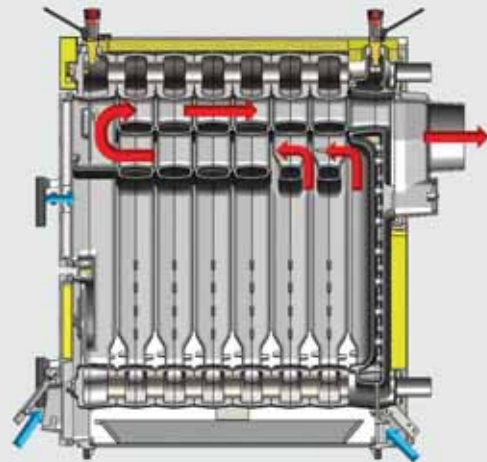
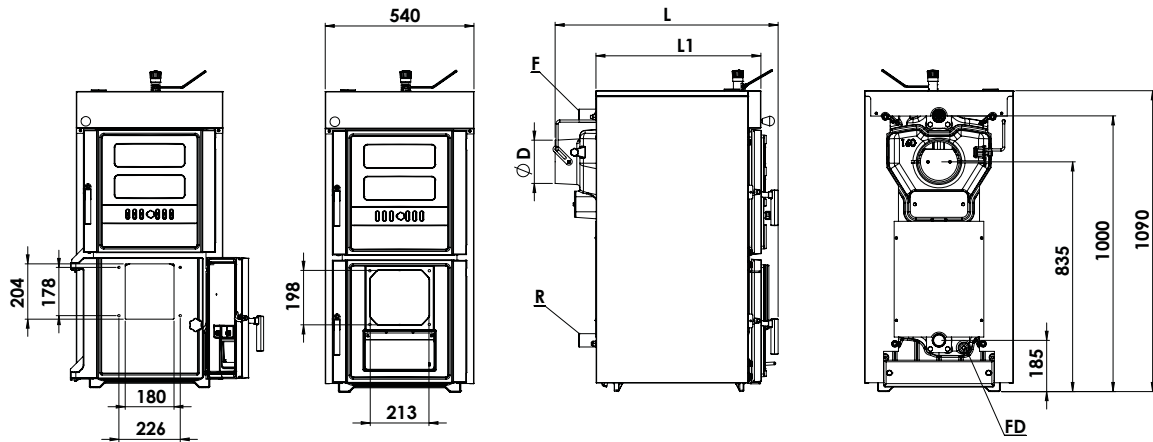

- Firing wood logs, brown coal, lignite, coke, and pellet (with combined pellet burner)
- Water-cooled bottom grate
- Scaled thermometer
- Optional cooling loop with safety valve
- Chimney flap controlled by front knob
- EN-GJL 200 grade grey cast iron boiler body, good finishing
- Optional version with fan and electronics

Model		LOGAN								
		KL 3	KL 4	KL 5	KL 6	KL 7	KL 8	KL 9	KL 10	
Types			KL 4F	KL 5F	KL 6F	KL 7F	KL 8F	KL 9F	KL 10F	
Description of boiler		Manually stocked, cast iron sectional boilers, for solid fuels in 3pass flue circulation principle								
Number of sections	pcs.	3	4	5	6	7	8	9	10	
Output range	(Coal) kW	16-20	22-30	32-40	42-50	52-60	62-70	72-80	82-90	
	(Wood) kW	14-16	18-24	26-32	34-40	42-48	50-56	60-66	70-76	
	(Pellet) kW	18	26	34	42	50				
Water Content	lt	27,5	34	41	47,5	54	60,5	66,5	73	
Combustion chamber		Height 485 mm X Width 360 mm								
Max. logwood length	mm	200	300	400	500	600	700	800	900	
Max. fuel loading height	mm	425								
Temperature control range	°C	50 - 90								
Max. operating temperature	°C	100								
Max. operating pressure	bar	4								
Water flow/return (F / R)	G	1 ½"								
Filling / draining (FD)	G	½"								
External dimensions	L	mm	610	710	810	910	1010	1110	1210	1310
	L2	mm	400	500	600	700	800	900	1000	1100
Flue outlet (D)		mm	160				175			

Cast Iron Boiler

KAPPA

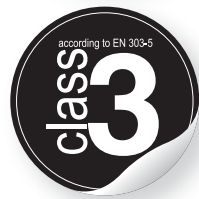

with pellets

12 to 70 kW
Two pass flue circulation
Compact design
Optional pellet door
Manual loading

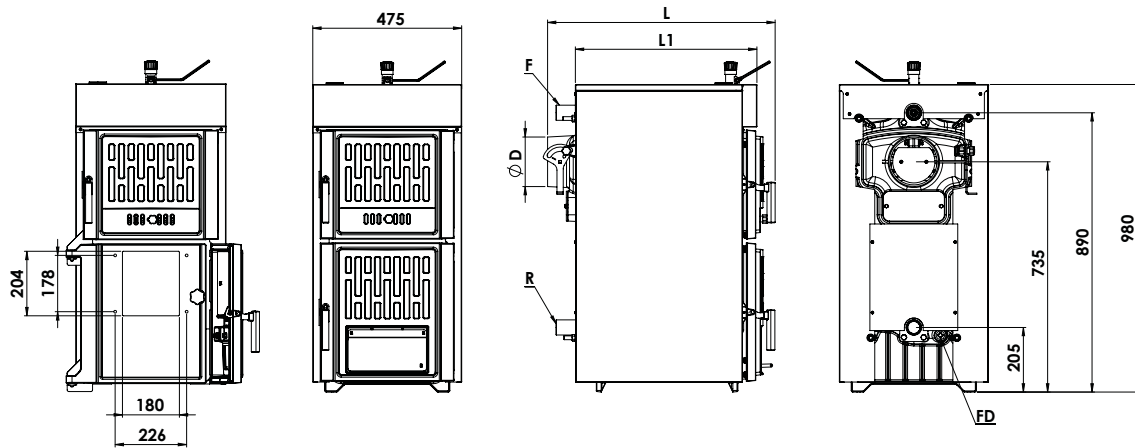

- Firing wood logs, brown coal, lignite, coke, and pellet (with combined pellet burner)
- Water-cooled and finned bottom grate
- Scaled thermometer
- Optional cooling loop with safety valve
- EN-GJL 200 grade grey cast iron boiler body, good finishing
- Optional version with fan and electronics

Model		KAPPA								
Types		KP 3	KP 4	KP 5	KP 6	KP 7	KP 8	KP 9	KP 10	
			KP 4F	KP 5F	KP 6F	KP 7F	KP 8F	KP 9F	KP 10F	
Description of boiler		Manually stocked, cast iron sectional boilers, for solid fuels in 2pass flue circulation principle								
Number of sections	pcs.	3	4	5	6	7	8	9	10	
Output range	(Coal) kW	15-18	22-26	28-32	34-38	40-46	48-54	56-62	64-70	
	(Wood) kW	12-14	18-22	24-28	30-34	36-42	44-48	50-56	58-64	
	(Pellet) kW		24	32	38	45				
Water Content	lt	22	27,5	33,5	39,5	45,5	51,5	57,5	63,5	
Combustion chamber		Height 425 mm X Width 315 mm								
Max. logwood length	mm	200	300	400	500	600	700	800	900	
Fuel loading clearance	mmxmm	330 x 324								
Max. fuel loading height	mm	375								
Temperature control range	°C	50 - 90								
Max. operating temperature	°C	100								
Max. operating pressure	bar	4								
Water flow/return (F / R)	R	1 ½"								
Filling / draining (FD)	R	½"								
External dimensions	L	mm	525	625	725	825	925	1025	1125	1225
	L2	mm	380	480	580	680	780	880	980	1080
Flue outlet (D)	mm	160						175		







BOYSİS Makine Taahhüt Sanayi ve Ticaret A.Ş.

Headquarters: Şerifali Mah. Hüsrev Sk. No:2 / 3 Ümraniye/İstanbul/TURKEY

Factory: Bandırma OSB 129. Ada Bandırma/Balıkesir/TURKEY

Branch: Üçevler Mah. Ritim Sk. Ofismer2 No:12/12A Nilüfer/Bursa/TURKEY

E-mail: info@thermasis.com

www.thermasis.com