

Fault Code	Fault Type	Reason	Solution
	When Deceleration	2. Load is too heavy; 3. The power of controller is small	<ul style="list-style-type: none"> ● Increase braking unit; ● Select bigger power controller
OC3	Over-current When Constant Speed Running	1. Sudden change of load; 2. Low input voltage; 3. The power of controller is small	<ul style="list-style-type: none"> ● Check the load; ● Check the power supply; ● Select bigger power controller
OV1	Over-voltage When Acceleration	1. High input voltage; 2. Regenerative energy from the motor is too large	<ul style="list-style-type: none"> ● Check the power supply; ● Avoid to restart the motor until it stop running completely
OV2	Over-voltage When Deceleration	1. Dec. time is too short; 2. Load is too heavy; 3. High input voltage	<ul style="list-style-type: none"> ● Increase Dec. time; ● Increase braking unit; ● Check the power supply
OV3	Over-voltage When Constant Speed Running	1. High input voltage; 2. Load is too heavy	<ul style="list-style-type: none"> ● Install input reactor; ● Increase braking unit
OV	Hardware over-voltage	1. Input voltage abnormal. 2. Dec. time is too short; 3. Load is too heavy	<ul style="list-style-type: none"> ● Check the power supply ● Increase Dec. time; ● Increase braking unit
UV	DC Bus Under-voltage	1. Low input voltage	<ul style="list-style-type: none"> ● Check the grid's input power supply
OL1	Controller Overload	1. Acc. time is too short; 2. Restart the motor when it is decelerating; 3. Low input voltage; 4. Load is too heavy	<ul style="list-style-type: none"> ● Increase Acc. time; ● Avoid to restart the motor until it stop running completely; ● Check the power supply; ● Select bigger power controller
OL2	Motor Overload	1. Low input voltage; 2. Wrong setting of motor parameter; 3. Motor locked-rotor or sudden big change of load to small load; 4. The power of motor is too small	<ul style="list-style-type: none"> ● Check the power supply; ● Set the rated current of motor properly; ● Check the load, adjust the value of torque boost; ● Select proper power motor
OL3	Over-torque	1. Acc. time is too short; 2. Restart the motor when it is decelerating; 3. Low input voltage; 4. Load is too heavy	<ul style="list-style-type: none"> ● Increase Acc time; ● Avoid to restart the motor until it stop running completely; ● Check the power supply; ● Select bigger power controller
SPO	Output Phase Failure (SPO)	1. Open-phase occurred at output side of main circuit	<ul style="list-style-type: none"> ● Check the output wiring connecting, cable and motor
OH	IGBT Overheat	1. Sudden over-current; 2. Input/output side has short	<ul style="list-style-type: none"> ● Refer to measures of over-current;

Fault Code	Fault Type	Reason	Solution
		circuit; 3. Cooling fans of controller stopped or damaged; 4. Ambient temperature is too high; 5. Wires or connectors of control board are loose; 6. Auxiliary power supply unit is damaged or low driving voltage for IGBT; 7. Power module bridge is damaged; 8. Control board is abnormal	<ul style="list-style-type: none"> ● Check the wiring; ● Replace cooling fans; ● Decrease the ambient temperature; ● Check and reconnect; ● Ask supplier for support
ITE	Current Detection Fault	1. Wires or connectors of control board are loose; 2. Auxiliary power supply unit is damaged; 3. Current detector is damaged or amplifying circuit is abnormal	<ul style="list-style-type: none"> ● Check the wiring and connectors; ● Ask supplier for support
ERR	EEPROM Fault	1. R/W fault of control parameters	<ul style="list-style-type: none"> ● Press ENT/RST to reset; ● Ask for support
E095	Communication Fault	1. Display circuit board is bad connection with the main circuit board	<ul style="list-style-type: none"> ● Check the wiring and connectors; ● Ask supplier for support

7.2 System Running Fault and Trouble Shooting

Abnormal Function	Reason	Solution
Can't Sleep	1. Outlet pipe leakage; 2. Check valve leakage; 3. Pressure tank damage; 4. High environment EMI; 5. Wrong parameter	<ul style="list-style-type: none"> ● Check outlet pipe, or to set b00.13; ● Inspect check valve; ● Change pressure tank; ● Transducer adopt shielded wires, shielded layer connect to PE; ● Ensure b00.10
Full-Frequency Running	1. Lose pressure feedback; 2. Wrong parameter; 3. Pump under power	<ul style="list-style-type: none"> ● Check transducer and wires; ● Set b00.23=1, take a factory reset
Motor Noise	1. Motor abnormal; 2. Motor installation is not stable; 3. Low carry-frequency	<ul style="list-style-type: none"> ● Check motor; ● Proper turn up carrier frequency b00.21

Contents

PREFACE.....	1
1 SAFETY PRECAUTIONS.....	2
2 PRODUCT SPECIFICATION.....	3
2.1 Model Specification.....	3
2.2 Selection Guide.....	3
2.3 External Dimension.....	3
3 WIRING.....	4
3.1 Control Terminals Overall Connect.....	4
3.2 Control Circuits Terminals Instructions.....	4
3.3 Sensor Wiring Diagram.....	5
4 OPERATION.....	6
4.1 Operation Panel.....	6
4.2 Keypad Description.....	6
4.3 Prefix Letter of Display interface definition.....	7
4.4 Parameter Setting.....	7
5 INSTRUCTIONS of PARAMETERS GROUP.....	8
6 FAST DEBUGGING INSTRUCTIONS.....	10
6.1 Parameter Setting.....	10
7 FAULT and TROUBLE SHOOTING.....	11
7.1 Controller Running Fault and Trouble Shooting.....	11
7.2 System Running Fault and Trouble Shooting.....	13

PREFACE

Thanks for choosing our product, we will supply you with considerate service as well as ever.

With high quality, multi-function, low noise and strong commonality etc. characteristics, WLD190 multi-function energy-saving controller is suitable to full-automatic operation.

- Professional design based on users' needs, simplicity of operation and suitable for all kinds of applications;
- According to the water condition to supply constant pressure water without manual operation after parameters were set correctly;
- Stop running automatically when no water consumption;
- Alarm automatically when faults occurred;

1 SAFETY PRECAUTIONS

WLD190 is a new power electronic product, please read the operation manual carefully before using to keep your safety and make sure proper operation.

In this manual, the safety precautions were sorted to “WARNING” and “CAUTION”.

⚠ WARNING: Wrong using may result in death or serious personal injury.

⚠ CAUTION: Wrong using may result in the damage of controller or system.

⚠ WARNING

- Please don't dismantle, change the product, or may cause electric shock, fire hazard and personal injury;
- Please don't open the cover during the running of controller;
- Please don't put wire, bar of metal, filaments etc. into the controller so as not to cause a short circuit or get an electric shock;
- After controller powered on, its cannot be touched even if in down state as the terminals of the controller are still live, otherwise, there is a risk of electric shock
- Please don't splash water or other liquid over the controller.
- Wiring work is performed by qualified electricians, and construct is performed in accordance with electrical code.

⚠ CAUTION

- Please don't make withstand voltage testing for the controller;
- Never connect AC power to output UVW terminals;
- If the internal components of the controller were influenced or damaged by static, please do not to touch;
- The motor, controller and power specifications should be matching, otherwise it could cause abnormal operation even burn out the device;
- If the controller appears serious vibration, noise, heat or peculiar smell in the first operation, please cut off the power immediately and contact suppliers or service center later;
- Please don't install the controller in the environment with direct sunlight, rain, frost or snow in case of deformation or damage.
- When the IPM module reaches a certain temperature, the cooling fan of Inverter will rotate. Please do not touch the cooling fan of Inverter casually.

2 PRODUCT SPECIFICATION

2.1 Model Specification

WLD190-2 001-1

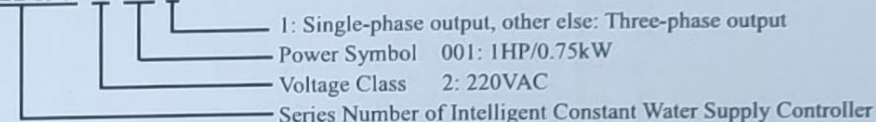

2.2 Selection Guide

Table2.2.1WLD190 list

Model No.	Rated Input Voltage (V)	Input Current (A)	Max. Output Current (A)	Motor Power (kW)
WLD190-2001-1	1AC: 220V ± 15%,50/60Hz	8.2	5.3	0.75
WLD190-20015-1		14.2	6.5	1.1
WLD190-2002-1		23.0	9.6	1.5

2.3 External Dimension

Unit: mm

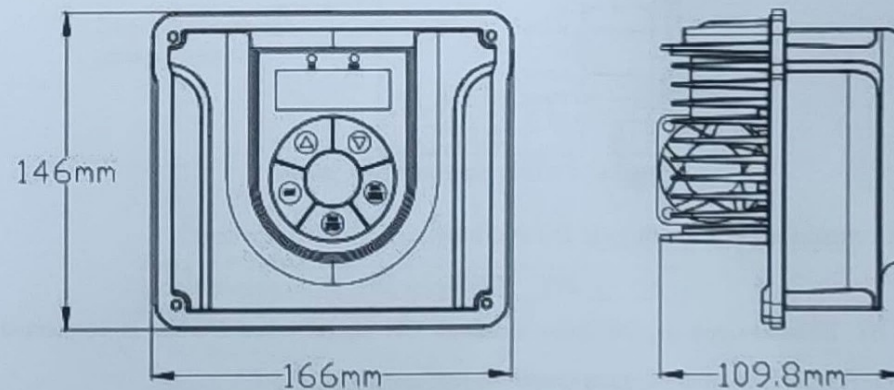

Figure2.1 Dimension

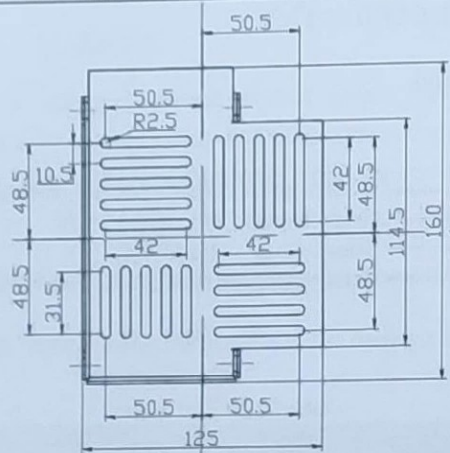

Figure 2.2 Base plate dimension

3 WIRING

3.1 Control Terminals Overall Connect

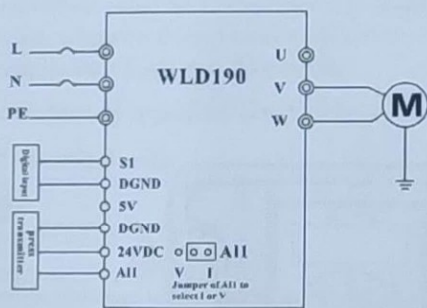

Figure 3.1 Wiring diagram (Single phase)

3.2 Control Circuits Terminals Instructions



S1: Normal-open digital input terminal, ON signal when DGND is connected and OFF signal when is on open circuit.

AII: Sensor input terminal of outlet side, which is a 0.5~4.5V analog voltage or 4~20mA analog current input terminal. As figure showed, AII jumper cap on the display is for AII signal type selection.

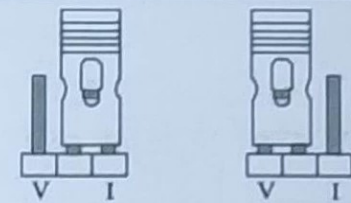

Input Signal Type Selection (Short Plug)
Current-feedback signal selection I, voltage feedback signal selection V.

DGND: Power ground, 5V and 24V refer to zero potential.

3.3 Sensor Wiring Diagram

The controller can connect two type sensors: 24V power supply, output 4~20mA current-feedback type pressure sensor and 24V power supply, output 0.5~4.5V voltage feedback type pressure sensor.

Please connect the wiring as below according to pressure sensor type.

1) Two-wire current-feedback type pressure sensor: Rated working voltage 24V, output signal 4~20mA, the wiring is as follows.

Current feedback pressure sensor

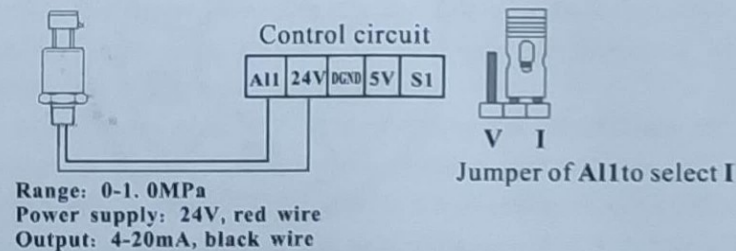

Figure 3.2 Current feedback type pressure sensor

2) Three-wire voltage feedback type pressure sensor: Rated working voltage 24V output signal 0.5~4.5V, the wiring is as below.

Voltage feedback
pressure sensor

Figure3.3 Voltage feedback type pressure sensor

4 OPERATION

4.1 Operation Panel

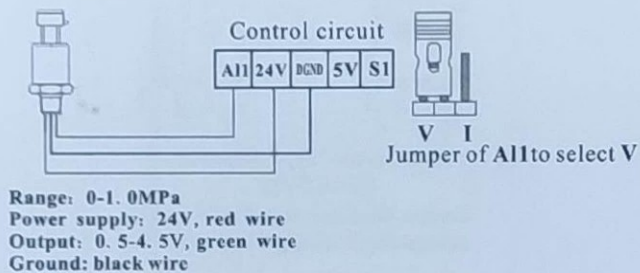
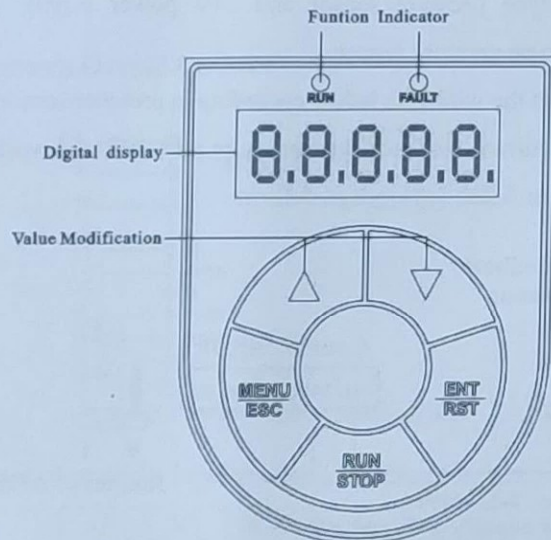

Figure4.1 Keypad schematic diagram

4.2 Keypad Description

1. ▲, ▼ Key: Digital modification key, used to set the pressure value, parameter modification.
 - ① The set pressure can be modified when in the stop state;
 - ② In the running state, press ▲ or ▼ key to increase or decrease the pressure value; press the ▲ and ▼ key simultaneously to switch the display state parameter.

2. MENU/ESC Key: Menu/ESC Key, Pressing more than 1 second can change the status display to the parameter setting mode.
3. ENT/RST Key: Data validation/Failure Rest Key.
4. RUN/STOP Key: Run or Stop Key.

4.3 Prefix Letter of Display interface definition

- H: Operating Frequency
P: The Actual Pressure of Pump Outlet
L: The Setting Pressure of Pump Outlet
A: Output current
d: DC Bus Voltage

4.4 Parameter Setting

Three levels of menu are: 1. Function code group (first-level); 2. Function code (second-level); 3. Function code setting value (third-level).

- At the primary interface, press ▲ or ▼ will switch and display running/stop status monitoring parameters;
- At the primary interface, long press MENU/ESC Key will enter the first-level menu, then short press MENU/ESC Key will return to the primary interface;
- At the first-level menu, press ENT/RST Key will enter the second-level menu. In second-level menu, press ENT/RST Key will enter the third-level, while press MENU/ESC Key will return to first-level menu;
- At third-level menu, press both MENU/ESC Key and ENT/RST Key can return to the second-level menu, difference is: pressing ENT/RST Key will save the parameters into the controller and return to the second-level menu with shifting to the next function code automatically; while pressing MENU/ESC Key will directly return to the second-level menu without saving the parameters, and keep staying at the current function code.

Under the third level menu, if the data bit flashes, it can be modified, otherwise it cannot be modified. When there are multiple modifiable data bits, flashing indicator automatically shift to the right and loop back and forth.

Example 1: Change default pressure setting 3.0 bar to 2.5 bar

Method 1: Enter parameter setting

Operation Step:

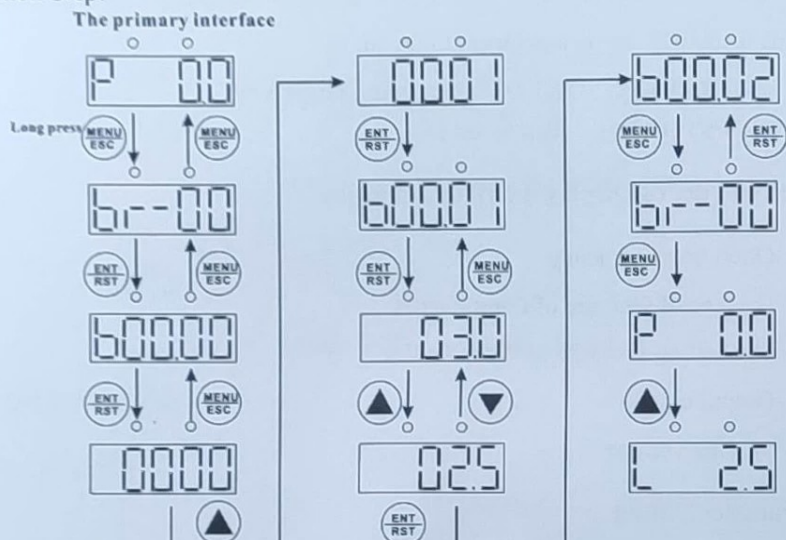

when the data is multiple, the scintillation position automatically moves right to the next

Figure 4.2 Operation flow chart

Method 2: Directly setting at the primary interface

Press ▲ or ▼ at primary interface when the inverter is in stop or run status, the system will switch-over automatically to display setting pressure, press ▲ or ▼ again, the setting pressure increase/decrease. In the adjustment process, the controller will automatically track to operate and automatically saves the pressure value.

5 INSTRUCTIONS of PARAMETERS GROUP

Function Code	Name	Setting Range	Factory Setting	Description
b00.00	Debugging Password	0~9999	0001	
b00.01	Pressure Setting Value	1.0~b00.03-1bar	3.0	Set according to the actual requirements of user
b00.02	Motor Rotating Direction	0~1	0	0: Forward 1: Reverse
b00.03	High Water Pressure Alarm Value	0~b00.06bar	8.0	When pressure is higher than this preset value, the controller halts and alarms

Function Code	Name	Setting Range	Factory Setting	Description
b00.04	Low Water Pressure Alarm Value	0~b00.01bar	0.5	When pressure is lower than the preset value for a low pressure running time, the controller halts and alarms.
b00.05	Low Pressure Running Time	0.0~900.0s	40	
b00.06	Maximum Transducer Setting Range	0.1~500.0 bar	10.0	E.g. If the rated max. range of transducer is 10bar, b00.06 should be set to 10.0
b00.07	Restart After Power-on	0~1	1	0: invalid 1: valid
b00.08	All Feedback Lost Detecting Value	0~1.00	0.10	Transducer fault detecting setting value, corresponding to full range (1.00), when the detecting time exceeds feedback lost time, it is deemed as malfunction by transducer, the system will report E022 as transducer fault code.
b00.09	Feedback Lost Detecting time	0~3600	2.0	
b00.10	Sleeping Function	0~1	1	0: Invalid 1: Automatic sleep
b00.11	Sleep detection coefficient	0.0~10.0	3.0	If it is difficult to sleep, please decrease the setting value.
b00.12	Sleep detection cycle	10~3600s	30	
b00.13	Wake-up Pressure Bias	0.0~b00.01bar	0.3	During sleeping the wake-up pressure bias, e.g. the setting value (L)=3.0bar, Bias (b00.13)=0.3bar, practical pressure (P)<L-0.3=2.7bar, the pump will restart again.
b00.14	Sleeping Bias	0.0~b00.01bar	0.12	The pressure fluctuation which allows sleeping
b00.15	Water Level Control	0~2	2	0: Invalid 1: Valid 2: Low water level
b00.16	Water Shortage Error Delay Time	0~9999min	15min	When there is Water Shortage Error, if b00.16≠0, it automatically reset after the delay time of the controller, if b00.16=0, it automatically reset to water shortage by pressure.
b00.17	Acceleration Time	0.1~3600s	3.0	The setting time from zero to max. frequency
b00.18	Deceleration Time	0.1~3600s	2.0	The setting time from max. frequency to zero
b00.19	Upper limit of	b00.20~60.00	50.00	Maximum running frequency

Function Code	Name	Setting Range	Factory Setting	Description
	Output Frequency			
b00.20	Lower Limit of Output Frequency	0.00~b00.19	20.00	The minimum running frequency of pump
b00.21	Carrier Frequency	1.0~15.0kHz	Model Set	Use to ameliorate the noise of motor and controller's interference to the surroundings. A high carrier makes a low motor noise, but leads to a big temperature rise and interference. Should not be altered if unnecessary.
b00.22	Software Version			
b00.23	Restore Defaults	0~2	0	0: No action 1: Set to default 2: Clear error records
b00.24	Latest Fault Type			Refers to chapter 7
b00.25	Motor Rated Power	0~2.2kW	Model Set	Depend on model, setting parameters according to nameplate of motor
b00.26	Motor Rated Frequency	0.01~60.0Hz	50.00Hz	
b00.27	Motor Rated Speed	0~3600rpm		
b00.28	Motor Rated Voltage	0~280V	Model Set	
b00.29	Motor Rate Current	0.1~15.0A		
b00.30	Reserved			

6 FAST DEBUGGING INSTRUCTIONS

6.1 Parameter Setting

For example, 24V power supply, 4~20mA current output, and 1MPa (0~10bar) transducer range, it need 2.5 bar pressure valve. The parameters are set as follow:

Function Code	Factory Setting	Setting Value	Description
b00.01	3.0	2.5	The pressure of water supply
b00.06	10	10	The rated max. range of transducer

Starting controller after setting the parameters and confirm whether the pump

steering is rotating forward. If the pump rotate reversely, it can be modified by follow two methods:

(1) Stop the controller and switch off the power supply, exchange any two wires of the motor output wires U, V, W.

(2) Stop the controller and modify parameter b00.02.

7 FAULT and TROUBLE SHOOTING

7.1 Controller Running Fault and Trouble Shooting

Fault Code	Fault Type	Reason	Solution
LP	Low Water Level	1. Sensor fault; 2. Motor rotates in reverse direction; 3. Insufficient water inflow; 4. There is air in pump	<ul style="list-style-type: none"> Check the pressure transmitter whether is normal; Check the motor's direction of rotation is correct or not; Check the parameter b00.04(setting value too big)
HP	High Water Pressure	1. Abnormal sensor; 2. The parameter b00.03 setting value is too small	<ul style="list-style-type: none"> Check the installation of pressure transmitter; Check the parameter b00.03 (setting value too small)
LL	Low water level	1. Water level of pool is too low 2. Abnormal water level switch	<ul style="list-style-type: none"> Check the water system Check the situation of the control terminal S1
E022	Sensor Fault	1. Pressure transmitter disconnected; 2. Wrong pressure transmitter wiring; 3. Pressure transmitter short circuit; 4. Pressure transmitter break down	<ul style="list-style-type: none"> Check the cable between pressure transmitter and controller; Check the sensor whether is normal
OUT	IGBT Fault	1. Acc./Dec. time is too short; 2. IGBT module fault; 3. Malfunction caused by interference; 4. Grounding is not properly	<ul style="list-style-type: none"> Increase Acc./Dec. time; Check external equipment and eliminate interference; Ask supplier for support
OC1	Over-current When Acceleration	1. Acc. time is too short; 2. Low input voltage; 3. The power of controller is small	<ul style="list-style-type: none"> Increase Acc. time; Check the power supply; Select bigger power controller
OC2	Over-current	1. Dec. time is too short;	<ul style="list-style-type: none"> Increase Dec. time;