

	Product model	YDWF67L150P2-B175X62
	Product type	External rotor axial flow fan
	Customer	乌克兰 (Ukraine)
	Product number	MAER - 20160101
	Certification	CE, CCC

Condition of use:

- 1) Voltage and frequency: 1 ~ 220V + 5% (50 Hz)
- 2) Qualification requirements. Lead cable: lead our, recommended lead wire is not less than 1.5m.
- 3) Installation position: vertical or upward.
- 4) Ambient temperature: -25 ~ 80°C.

THE EXTERNAL WIRING DIAGRAM:

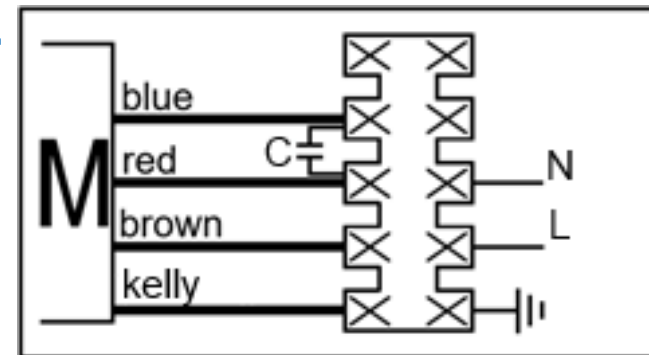

Performance parameters at key point:						
	psf	I	P1	n	Q	Note
	(pa)	(A)	(W)	(r/min)	(m³/h)	
①	0	0.22	51	2691	472	
②	86	0.23	53	2626	368	
③	155	0.24	54	2597	269	IMAX

WIRING DIAGRAM

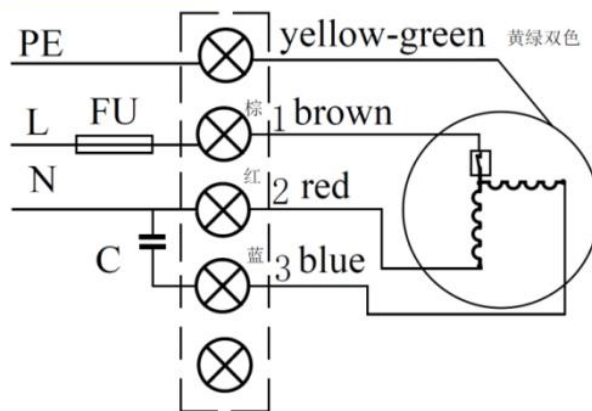

TECHNICAL SPECIFICATION:

1. All parts of fan should be properly assembled, no oil or dirt on the surface, no obvious distortion, mechanical damage and other defects.
2. Fan rotation is flexible; no delay no operation sound, no scratch and other undesirable phenomena.
3. The safety requirement of fan is performed according to GB12350-2009, the electrical strength is 1800V•min, and the insulation resistance is not less than 100M Ω at room temperature.
4. Motor insulation class, F CLASS.
5. Motor protection level, IP44, fan protection level, IP2X.
6. The fan balance level is: 2734± 10% r/min high G6. 3, vibration value is less than 5.4mm/s.

Test data at free:

Connection	UAC (V)±5%	f (Hz)	P1 (W)±10%	I (A)±10%	n (r/min)±10%	Noise db(A)
state	1 ~220V	50	54	0.23	2734	65

Nameplate:

	YDWF67L15P2-B175x62 1~220V50Hz 2μF / 450V 54W 0.24A 2597r/min @ 155Pa CL. F IP44 2018/07 Tel:+380678807231 web:www.iceteco.com e-mail:iceteco@gmail.com					state	Deliver before	The signature	(date) (month) (year)	ZHEJIANG MAER FAN MOTOR CO., LTD.
	drawing	After the confirmation				Product Specification				
	audit									
	approval									