

外转子轴流风机系列 AC AXIAL FAN

Φ500

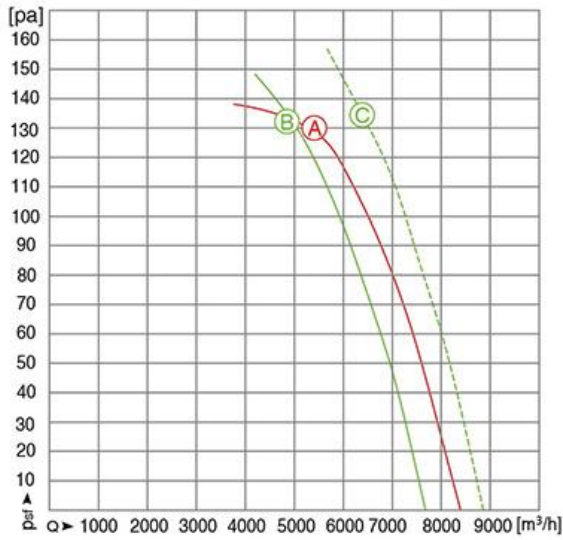

动压 / Dynamic pressure: $p_d = 1.2 \times 10^{-6} \times Q^2 (p_a)$

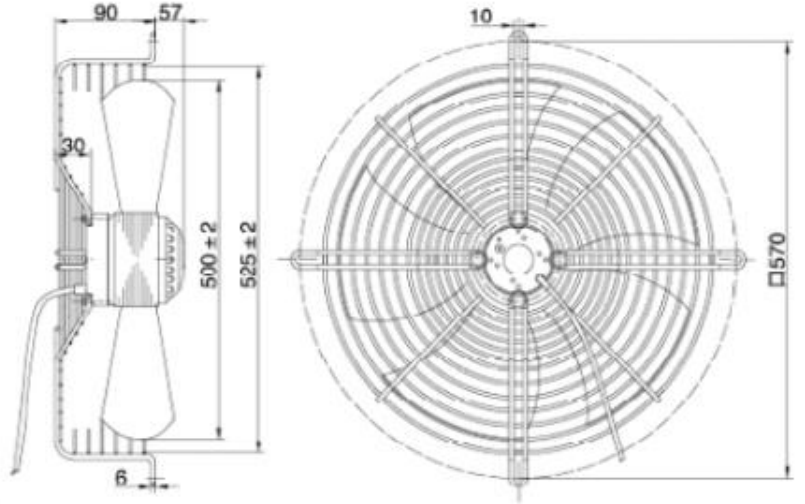
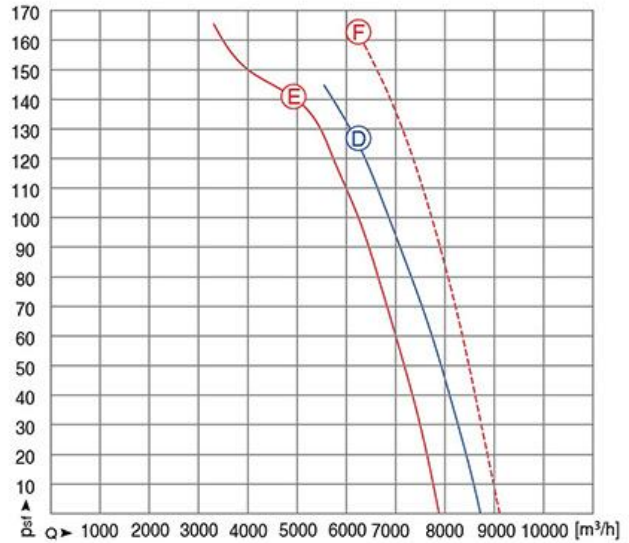

型号 MODEL	电压 UAC	频率 f	电容器 C	曲线 CURVE	输入功率 P1	转速 n	电流 I	静压 Psf	环境温度 Temp.	静压效率 ηsf	能效值 EFF. Grade	噪声 Noise	备注 Note
	V	Hz	μF/450V	NO.	W	r/min	A	Pa	℃	%	N	dB(A)	
YDWF102L60P4-□-500	1~220	50	20	A	710	1364	3.23	131	-40~+70	27.04	34.2	73	
YDWF102L60P4-□-500	1~220	50	20	B	591	1402	2.69	133	-40~+80	30.82	38.5	72	
YDWF102L60P4-□-500	1~220	60	20	C	897	1566	4.10	135	-40~+65	36.64	33.2	75	
YSWF102L60P4-□-500	3~380	50	—	D	733	1369	1.37	127	-40~+70	29.72	36.8	73	
YSWF102L60P4-□-500	3~380	50	—	E	616	1401	1.26	141	-40~+80	31.11	38.7	72	
YSWF102L60P4-□-500	3~380	60	—	F	948	1594	1.62	165	-40~+65	29.82	36.2	75	

注：性能曲线在安装马尔导风圈时测得；□表示安装附件。

Note: the performance curve obtained by installation MAER wall plate measurement ; □ express installation accessories.